

END OF PROPOSED
 DUCT BANK

NEW DUCT MARKER SHALL BE
 INSTALLED AT ALL PROPOSED
 DUCT BANK LOCATIONS SHOWN
 ON THE PLANS

DUCT MARKERS SHALL BE RECESSED
 AND GROUTED INTO THE PAVEMENTS.

MARKER PLACEMENT

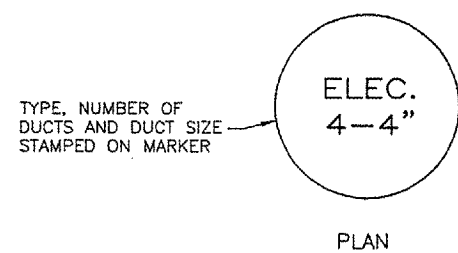

PLAN

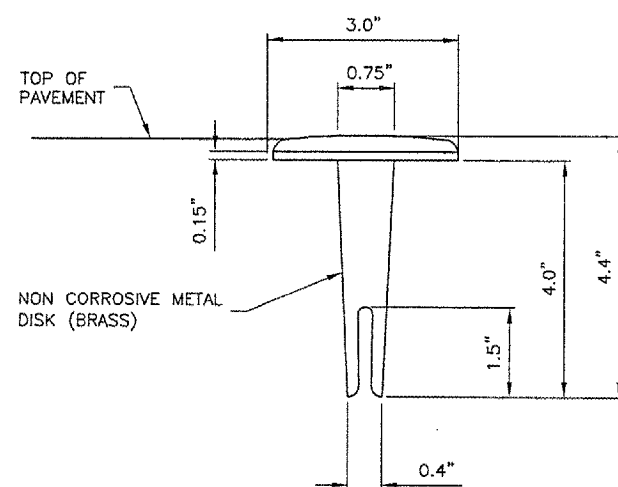

SECTION

DUCT MARKER DETAILS

N.T.S.

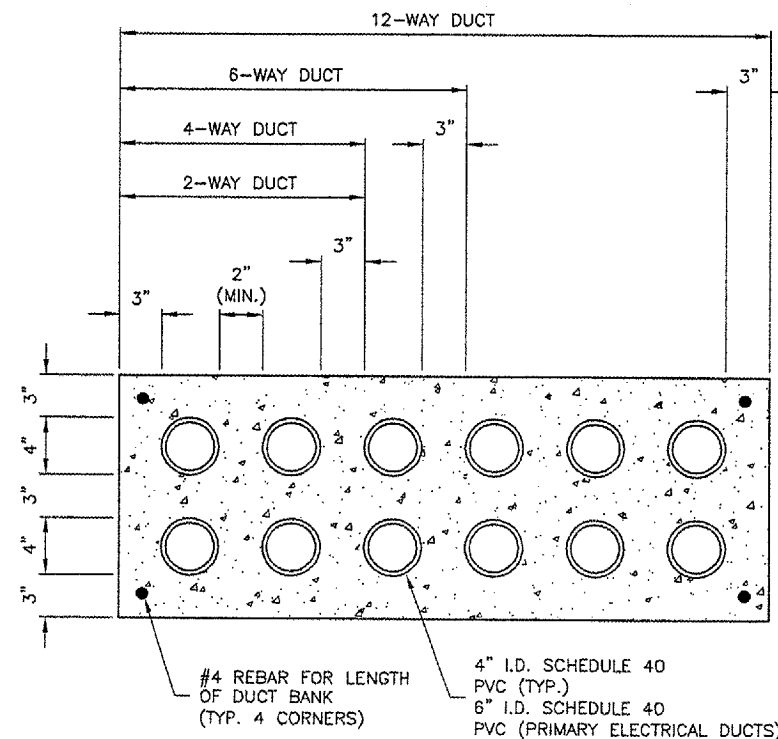

#4 REBAR FOR LENGTH
 OF DUCT BANK
 (TYP. 4 CORNERS)

4" I.D. SCHEDULE 40
 PVC (TYP.)
 6" I.D. SCHEDULE 40
 PVC (PRIMARY ELECTRICAL DUCTS)

DUCT BANK DETAIL

N.T.S.

NOTES

- DIMENSIONS SHOWN ARE MINIMUM.
- TOP OF CONCRETE ENCASEMENT TO BE NOT LESS THAN 18" BELOW FINISHED SUBGRADE.
- DUCT CONCRETE SHALL BE ITEM 610 STRUCTURAL P.C.C. CONCRETE.
- ALL DUCT SHALL BE 4" INSIDE DIAMETER.
- LOCATIONS SHOWN ARE APPROXIMATE. DUCT BANKS SHALL BE INSTALLED AT LOCATIONS DESIGNATED BY THE ENGINEER.
- CONTRACTOR SHALL INSTALL DUCT BANKS AT A DEPTH WHICH WILL NOT CONFLICT WITH ELEVATION SENSITIVE UTILITIES.
- A PULL WIRE SHALL BE PROVIDED IN EACH UNUSED CONDUIT. UNUSED DUCT SHALL BE SEALED WITH PVC PLUGS/CAPS TO THE SATISFACTION OF THE ENGINEER.
- DUCT BANKS SHALL EXTEND A MINIMUM OF 5' BEYOND THE PROPOSED EDGE OF PAVEMENT.

REVISIONS

NUMBER	BY	DATE

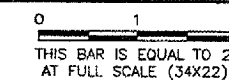

BLOOMINGTON-NORMAL AIRPORT AUTHORITY
 CENTRAL ILLINOIS REGIONAL AIRPORT
 BLOOMINGTON, ILLINOIS

CONSTRUCT TAXIWAY G-1
 ELECTRICAL DETAILS SHEET 2

© Copyright GMT, Inc.

GMT
 CRAWFORD, MURPHY & TILLY, INC.
 CONSULTING ENGINEERS
 License No. 184-000613



DESIGN BY: JEF

DRAWN BY: DPA

CHECKED BY: RLV

APPROVED BY: JEF

DATE: 1/13/2006

JOB No: 05085-0300

ILLINOIS PROJECT BMI-3452
 A.I.P. PROJECT 3-17-0006-XX

SHEET 21 OF 33 SHEETS