

BENCHMARK #1
Chiseled "X" on W. End of E.
Upstream Wingwall of
Miner/Northwest Hwy. Bridge
over Des Plaines River
Elev. 639.04

BENCHMARK #2
Chiseled "X" on M.H. Rim
N. Side of Miner/Northwest Hwy. @
S.W. Corner of Precision Instruments
Elev. 631.30

BENCHMARK #3
Chiseled "X" on M.H. Rim
N. Side of Miner/Northwest Hwy. @
Entrance to Z Car Service Center
Elev. 630.99

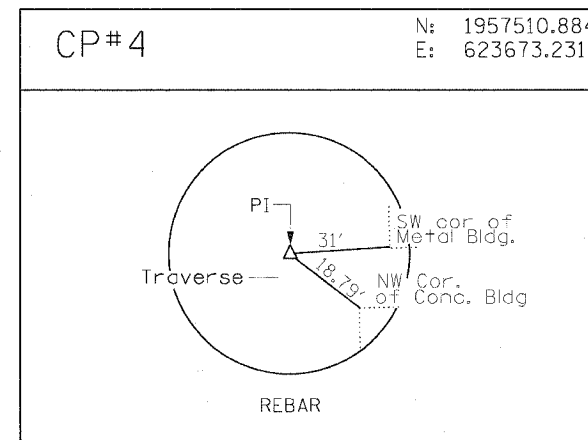
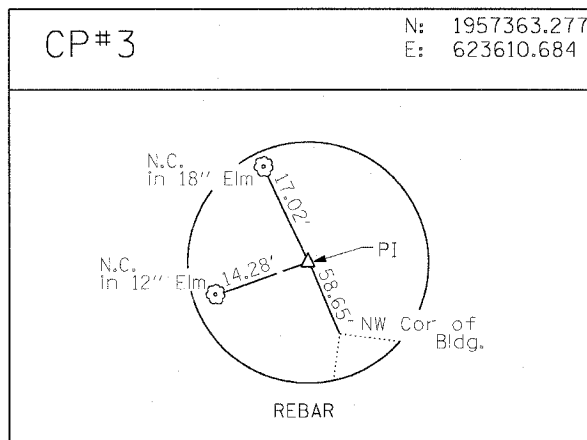

BENCHMARK #4
D.O.W. Disk Set in Concrete
@ S.E. Corner of Rand Rd. and
Ballard Rd. 40'± S. of Ballard and
118'± E. of Rand Rd.
Elev. 633.266

BENCHMARK #5
Chiseled "X" on Signal Base
N.W. Corner of Bender Rd. and Ballard
Rd. 200'± West of Tri-State Tollway
Elev. 633.10

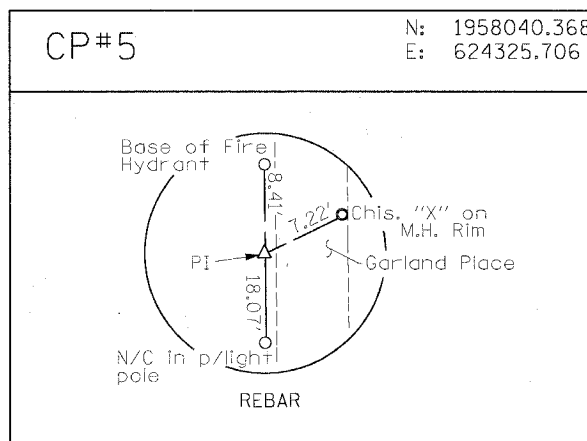

DESIGNED BY: _____
DRAWN BY: _____
CHECKED BY: _____
CHECKED BY: _____

01/30/2006 10:04:36 AM P:\P60003332\General\Shf\02g14.shf