

STATE OF ILLINOIS  
DEPARTMENT OF TRANSPORTATION

F.A.I. RTE.	SECTION	COUNTY	TOTAL SHEETS	SHEET NO.
72	(86-8)BDR1,BJR1,BRR1,BP	SCOTT	45*	1
		ILLINOIS	CONTRACT NO. 72136	

\* 45 + 3 = 48 TOTAL SHEETS

# PROPOSED HIGHWAY PLANS

ROUTE FAI 72 (I 72)  
SECTION (86-8)BDR1, BJR1, BRR1, BP  
PROJECT COVD-IA52(162)  
BRIDGE DECK OVERLAY  
SCOTT COUNTY

C-96-073-22

D-96-055-22

**INDEX OF SHEETS**

- 1 COVER
- 2 GENERAL NOTES
- 3-6 SUMMARY OF QUANTITIES
- 7-9 SCHEDULE OF QUANTITIES
- 10 TYPICAL SECTIONS
- 11-12 ALIGNMENT & ROAD LAYOUT LOCATION
- 13-14 PLAN
- 15-26 STAGING PLAN
- 27-31 DETAILS
- 32-45 BRIDGE PLANS
- 45A-45C EXISTING PLAN SHEETS

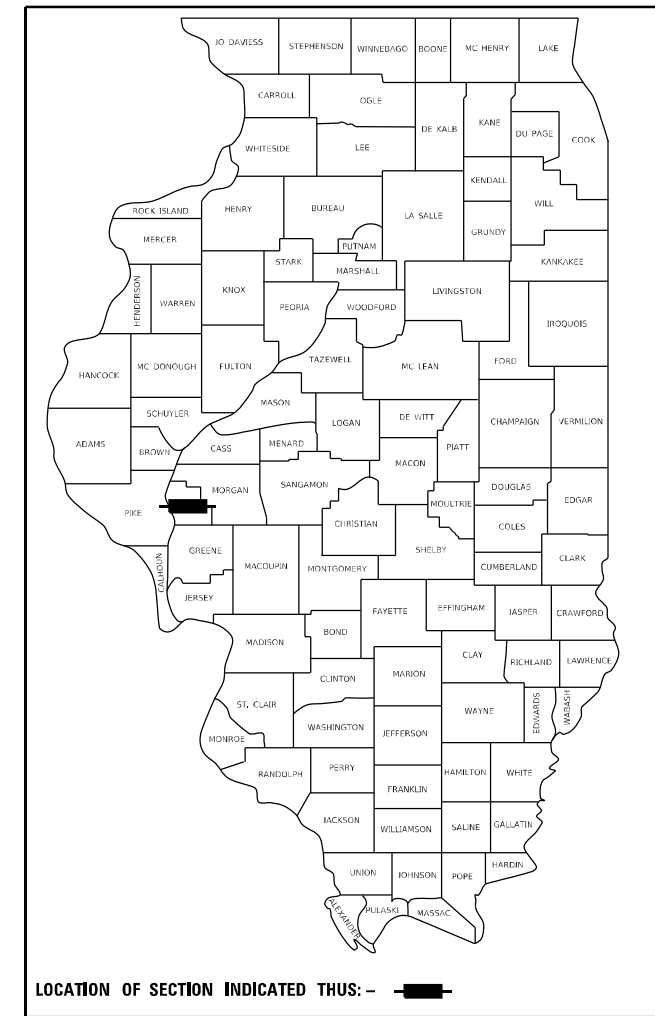

FUNCT. CLASS. = INTERSTATE  
ADT = 9,100 (2021)  
PV = 63.19%  
SU = 5.49%  
MU = 31.32%

STATE OF ILLINOIS  
DEPARTMENT OF TRANSPORTATION

SUBMITTED December 15, 2022

*John P. Meyer*  
REGIONAL ENGINEER

February 3, 2023  
*Scott A. Etkin*  
ENGINEER OF DESIGN AND ENVIRONMENT

February 3, 2023  
*Stephen M. Smith*  
DIRECTOR OF HIGHWAYS PROJECT IMPLEMENTATION

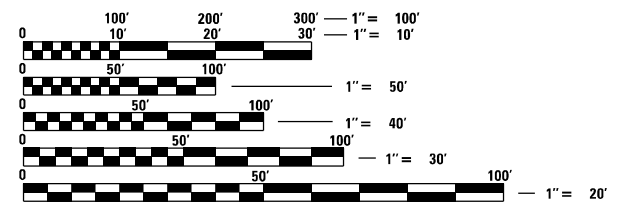

FULL SIZE PLANS HAVE BEEN PREPARED USING STANDARD ENGINEERING SCALES. REDUCED SIZED PLANS WILL NOT CONFORM TO STANDARD SCALES. IN MAKING MEASUREMENTS ON REDUCED PLANS, THE ABOVE SCALES MAY BE USED.

J.U.L.I.E.  
JOINT UTILITY LOCATION INFORMATION FOR EXCAVATORS  
1-800-892-0123  
OR 811

PROJECT ENGINEER: JON KELLEY  
PROJECT MANAGER: FRANK CARABALLO

CONTRACT NO. 72136

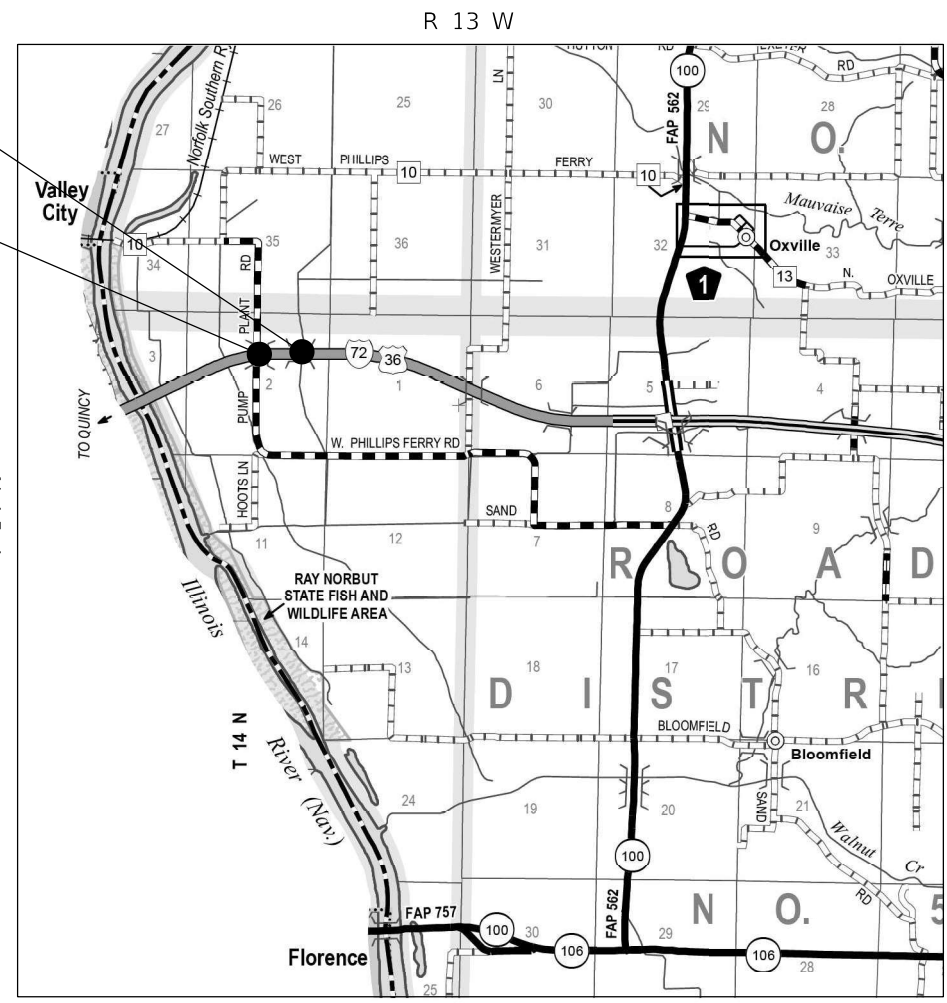

GROSS LENGTH = 3,000.00 FT. = 0.568 MILES  
NET LENGTH = 3,000.00 FT. = 0.568 MILES

**GENERAL NOTES**

- 1. SYNTHETIC FIBERS ARE NOT REQUIRED IN THE BRIDGE DECK MICROSILICA CONCRETE OVERLAY.

**HIGHWAY STANDARDS**

- 000001-08
- 001006
- 482011-03
- 606001-08
- 610001-09
- 631031-18
- 642001-03
- 701001-02
- 701101-05
- 701106-02
- 701201-05
- 701400-11
- 701401-13
- 701402-12
- 701901-08
- 704001-08
- 780001-05
- 781001-04
- 001001-02
- 420001-10
- 701006-05
- 701426-09
- 782006-01

**APPLICATION RATES**

HOT-MIX ASPHALT BASE COURSE	0.056	TON/SQ YD/IN
HOT-MIX ASPHALT SURFACE/BINDER COURSE	0.056	TON/SQ YD/IN
AGGREGATE WEDGE SHOULDERS	1.60	TON/CU YD
BITUMINOUS MATERIALS:		
TACK COAT:		
- BETWEEN HMA LIFTS	0.025	LB/SQ YD
- ON EXISTING HMA, MILLED SURFACE, CONCRETE, MILLED SURFACE	0.05	LB/SQ YD

**MIX REQUIREMENTS**

<b>Location(s):</b>	I-72 Mainline
<b>Mixture Use(s):</b>	HMA Surface Course
<b>PG:</b>	SBS PG 70-22 or SBS PG 70-28
<b>Design Air Voids:</b>	4.0% @ N70
<b>Mixture Composition:</b>	IL-9.5
<b>Friction Aggregate:</b>	Mix "D"
<b>Mixture Weight:</b>	112 lb/sy*in
<b>Quality Management:</b>	QC/QA
<b>Sublot Size:</b>	N/A
<b>Material Transfer Device</b>	No

<b>Location(s):</b>	I-72 Mainline
<b>Mixture Use(s):</b>	HMA Binder Course
<b>PG:</b>	SBS PG 70-22 or SBS PG 70-28
<b>Design Air Voids:</b>	4.0% @ N70
<b>Mixture Composition:</b>	IL-9.5
<b>Friction Aggregate:</b>	Mix "D"
<b>Mixture Weight:</b>	112 lb/sy*in
<b>Quality Management:</b>	QC/QA
<b>Sublot Size:</b>	N/A
<b>Material Transfer Device Required:</b>	No

<b>Location(s):</b>	I-72 Shoulder
<b>Mixture Use(s):</b>	HMA Shoulder
<b>PG:</b>	PG 64-22
<b>Design Air Voids:</b>	4.0% @ N50
<b>Mixture Composition:</b>	IL-9.5
<b>Friction Aggregate:</b>	Mix "C"
<b>Mixture Weight:</b>	112 lb/sy*in
<b>Quality Management:</b>	QC/QA
<b>Sublot Size:</b>	N/A
<b>Material Transfer Device</b>	No

<b>Location(s):</b>	I-72 Shoulder
<b>Mixture Use(s):</b>	HMA Base Course
<b>PG:</b>	PG 64-22
<b>Design Air Voids:</b>	4.0% @ N70
<b>Mixture Composition:</b>	IL-19.0
<b>Friction Aggregate:</b>	N/A
<b>Mixture Weight:</b>	112 lb/sy*in
<b>Quality Management:</b>	QC/QA
<b>Sublot Size:</b>	N/A
<b>Material Transfer Device</b>	No

**STATE OF ILLINOIS  
DEPARTMENT OF TRANSPORTATION  
DIVISION OF HIGHWAYS  
DISTRICT 6**

---

EXAMINED December, 5 20 22

*[Signature]*  
ENGINEER OF OPERATIONS

---

EXAMINED December, 13 20 22

*[Signature]*  
ENGINEER OF PROJECT IMPLEMENTATION

---

EXAMINED December, 13 20 22

*[Signature]*  
ENGINEER OF PROGRAM DEVELOPMENT

REV. - MS

MODEL: D:\default  
 FILE: M:\asphalt\pav\illinois\documents\DOT\_offices\District\_6\Projects\0672136\CADD\Draw\_531\0672136\0672136-ash-covers.dgn

CODE	ITEM	UNIT	TOTAL	6-00324-0100	
				100% FEDERAL	100% FEDERAL
				BRIDGE	BRIDGE
				0047	0047
	SN 086-0040 & SN 086-0041	SN 086-0042 & SN 086-0043			
28100107	STONE RIPRAP CL A4	SQ YD	1	1	
35501316	HOT-MIX ASPHALT BASE COURSE, 8"	SQ YD	3915	1780	2135
40600290	BITUMINOUS MATERIALS (TACK COAT)	POUND	5244	1998	3246
40600982	HOT-MIX ASPHALT SURFACE REMOVAL - BUTT JOINT	SQ YD	2773	1247	1526
40600990	TEMPORARY RAMP	SQ YD	1183	348	835
40603208	POLYMERIZED HOT-MIX ASPHALT BINDER COURSE, 1L-9.5, N70	TON	229	79	150
40604162	POLYMERIZED HOT-MIX ASPHALT SURFACE COURSE, 1L-9.5, MIX "D", N70	TON	356	134	222
48101200	AGGREGATE SHOULDER, TYPE B	TON	138	88	50
48203100	HOT-MIX ASPHALT SHOULDERS	TON	261	111	150
48300300	PORTLAND CEMENT CONCRETE SHOULDERS 8"	SQ YD	114	114	0
50102400	CONCRETE REMOVAL	CU YD	21.5	0	21.5
50300255	CONCRETE SUPERSTRUCTURE	CU YD	25	0	25
50300300	PROTECTIVE COAT	SQ YD	3464	1242	2222
50800205	REINFORCEMENT BARS, EPOXY COATED	POUND	3000	0	3000
50800515	BAR SPLICERS	EACH	48	0	48
52000110	PREFORMED JOINT STRIP SEAL	FOOT	168	0	168
60600605	CONCRETE CURB, TYPE B	FOOT	60	0	60

REV. - MS

MODEL: Default  
FILE: M:\msc\p\illinois\benley.com\p\DOT\Documents\DOT\_Offices\District\_8\Project\0672136\CADD\sub\_5310\CAD\sheet\0672136-ash-cover.dgn

USER NAME = Frank.Caraballo	DESIGNED -	REVISED -
	DRAWN -	REVISED -
PLOT SCALE = 100.0000' / in.	CHECKED -	REVISED -
PLOT DATE = 12/14/2022	DATE -	REVISED -

**STATE OF ILLINOIS  
DEPARTMENT OF TRANSPORTATION**

**SUMMARY OF QUANTITIES**

SCALE: SHEET OF SHEETS STA. TO STA.

F.A.I. RTE.	SECTION	COUNTY	TOTAL SHEETS	SHEET NO.
72	(86-8)BDR1,BJR1,BRR1,BP	SCOTT	45	3
			CONTRACT NO. 72136	
ILLINOIS FED. AID PROJECT				

CODE	ITEM	UNIT	TOTAL	6-00324-0100	
				100% FEDERAL	100% FEDERAL
				BRIDGE	BRIDGE
				0047	0047
				SN 086-0040 & SN 086-0041	SN 086-0042 & SN 086-0043
61000115	TYPE E INLET BOX, STANDARD 610001	EACH	2	2	0
61000335	TYPE G INLET BOX, STANDARD 610001	EACH	2	2	0
63100085	TRAFFIC BARRIER TERMINAL, TYPE 6	EACH	10	6	4
64200116	SHOULDER RUMBLE STRIPS, 16 INCH	FOOT	3146	1182	1964
66201120	CONCRETE SHOULDER CURB	FOOT	120	120	0
67000400	ENGINEER'S FIELD OFFICE, TYPE A	CAL MO	12	6	6
67100100	MOBILIZATION	L SUM	1	0.5	0.5
70100450	TRAFFIC CONTROL AND PROTECTION, STANDARD 701201	L SUM	1	1	
70100800	TRAFFIC CONTROL AND PROTECTION, STANDARD 701401	L SUM	1	0.5	0.5
70107025	CHANGEABLE MESSAGE SIGN	CAL DA	14	7	7
70300100	SHORT TERM PAVEMENT MARKING	FOOT	723	279	444
70300150	SHORT TERM PAVEMENT MARKING REMOVAL	SQ FT	243	93	150
70400100	TEMPORARY CONCRETE BARRIER	FOOT	2100	775	1325
70400200	RELOCATE TEMPORARY CONCRETE BARRIER	FOOT	2100	775	1325
* 78009005	MODIFIED URETHANE PAVEMENT MARKING - LINE 5"	FOOT	5406	2085	3321
* 78100100	RAISED REFLECTIVE PAVEMENT MARKER	EACH	60	23	37
78300200	RAISED REFLECTIVE PAVEMENT MARKER REMOVAL	EACH	60	23	37
78300201	PAVEMENT MARKING REMOVAL, GRINDING	SQ FT	2731	1093	1638

\* SPECIALTY ITEM

REV. - MS

MODEL: D:\default\pml\illinois\pml\illinois\pml\illinois\DOT\_Offices\District\_8\Project\0672136\CADD\plan\_5310\CAD\Sheet\0672136-ah-covez.dgn

USER NAME = Frank.Caraballo	DESIGNED -	REVISED -
	DRAWN -	REVISED -
PLOT SCALE = 100.0000' / in.	CHECKED -	REVISED -
PLOT DATE = 12/14/2022	DATE -	REVISED -

**STATE OF ILLINOIS  
DEPARTMENT OF TRANSPORTATION**

**SUMMARY OF QUANTITIES**

SCALE: SHEET OF SHEETS STA. TO STA.

F.A.I. RTE.	SECTION	COUNTY	TOTAL SHEETS	SHEET NO.
72	(86-8)BDR1,BJR1,BRR1,BP	SCOTT	45	4
			CONTRACT NO. 72136	
ILLINOIS FED. AID PROJECT				

CODE	ITEM	UNIT	TOTAL	6-00324-0100	
				100% FEDERAL	100% FEDERAL
				BRIDGE	BRIDGE
				0047	0047
SN 086-0040 & SN 086-0041	SN 086-0042 & SN 086-0043				
X1400432	REMOVE AND REINSTALL SHOULDER INLET DRAIN PIPE AND CONNECTION	EACH	4	4	0
X4401198	HOT-MIX ASPHALT SURFACE REMOVAL, VARIABLE DEPTH	SQ YD	3915	1780	2135
X5030250	BRIDGE DECK GROOVING (LONGITUDINAL)	SQ YD	2201	873	1328
* X5060601	CONTAINMENT AND DISPOSAL OF NON-LEAD PAINT CLEANING RESIDUES NO. 1	LSUM	1	0	1
* X5060602	CONTAINMENT AND DISPOSAL OF NON-LEAD PAINT CLEANING RESIDUES NO. 2	LSUM	1	0	1
X6050700	REMOVE INLET BOX	EACH	4	4	0
X6024503	INLETS TO BE ADJUSTED WITH NEW FRAME AND GRATE (SPECIAL)	EACH	8	0	8
X6320100	GUARDRAIL REMOVAL, SPECIAL	FOOT	475	275	200
X7010208	TRAFFIC CONTROL AND PROTECTION, STANDARD 701402 (SPECIAL)	EACH	2	1	1
X7200201	WIDTH RESTRICTION SIGNING	LSUM	1	0.5	0.5
Z0001495	BRIDGE APPROACH SHOULDER REMOVAL	SQ YD	114	114	0
Z0001800	APPROACH SLAB REPAIR (PARTIAL DEPTH)	SQ YD	40	0	40
Z0010501	CLEANING AND PAINTING STEEL BRIDGE NO. 1	LSUM	1	0	1
* Z0010502	CLEANING AND PAINTING STEEL BRIDGE NO. 2	LSUM	1	0	1
* Z0012130	BRIDGE DECK SCARIFICATION 3/4"	SQ YD	3426	1242	2184
Z0012166	BRIDGE DECK MICROSILICA OVERLAY 2 3/4"	SQ YD	3426	1242	2184
Z0012500	CONCRETE CURB REPAIR	FOOT	24	0	24

\* SPECIALTY ITEM

REV. - MS

MODEL: D:\default  
FILE: M:\mhc\p\m\illinois\benley.com\p\m\illinois\documents\DOT\_Offices\District\_8\Project\0672136\CADD\sub\_5310\CAD\sheet\0672136-ash-covez.dgn

USER NAME = Frank.Caraballo	DESIGNED -	REVISED -
	DRAWN -	REVISED -
PLOT SCALE = 100.0000' / in.	CHECKED -	REVISED -
PLOT DATE = 12/14/2022	DATE -	REVISED -

**STATE OF ILLINOIS  
DEPARTMENT OF TRANSPORTATION**

**SUMMARY OF QUANTITIES**

SCALE: SHEET OF SHEETS STA. TO STA.

F.A.I. RTE.	SECTION	COUNTY	TOTAL SHEETS	SHEET NO.
72	(86-8)BDR1,BJR1,BRR1,BP	SCOTT	45	5
CONTRACT NO. 72136				
ILLINOIS FED. AID PROJECT				

CODE	ITEM	UNIT	TOTAL	6-00324-0100	
				100% FEDERAL	100% FEDERAL
				BRIDGE	BRIDGE
				0047	0047
				SN 086-0040 & SN 086-0041	SN 086-0042 & SN 086-0043
Z0012754	STRUCTURAL REPAIR OF CONCRETE (DEPTH EQUAL TO OR LESS THAN 5 INCHES)	SQ FT	283	0	283
Z0016002	DECK SLAB REPAIR (FULL DEPTH, TYPE II)	SQ YD	37	5	32
Z0029090	DIAMOND GRINDING (BRIDGE SECTION)	SQ YD	3141	1150	1991
Ø Z0076600	TRAINEES	HOUR	1500	1500	
Z0041895	POLYMER CONCRETE	CU FT	41	41	0
Ø Z0076604	TRAINEES TRAINING PROGRAM GRADUATE	HOUR	1500	1500	

Ø 0042

REV. - MS

MODEL: Default  
FILE: M:\msc\paw\_bentley.com\PWIDOT\Documents\DOT\_Offices\Dirct. 8\Project\0672136\CADD\sub\_5310\CADD\sheet\0672136-ah-cover.dgn

USER NAME = Frank.Caraballo	DESIGNED -	REVISED -
	DRAWN -	REVISED -
PLOT SCALE = 100.0000' / in.	CHECKED -	REVISED -
PLOT DATE = 12/14/2022	DATE -	REVISED -

**STATE OF ILLINOIS  
DEPARTMENT OF TRANSPORTATION**

**SUMMARY OF QUANTITIES**

SCALE: SHEET OF SHEETS STA. TO STA.

F.A.I. RTE.	SECTION	COUNTY	TOTAL SHEETS	SHEET NO.
72	(86-8)BDR1,BJR1,BRR1,BP	SCOTT	45	6
CONTRACT NO. 72136				
ILLINOIS FED. AID PROJECT				

PAVING SCHEDULE												
LOCATION			LENGTH FOOT	WIDTH FOOT	40600290	40600982	40604162	40603208	48101200	48203100	64200116	
STATION	TO	STATION			BITUMINOUS MATERIALS (TACK COAT)	HOT-MIX ASPHALT SURFACE REMOVAL - BUTT JOINT	POLYMERIZED HOT-MIX ASPHALT SURFACE COURSE, IL-9.5, MIX "D", N70	POLYMERIZED HOT-MIX ASPHALT BINDER COURSE, IL-9.5, N70	AGGREGATE SHOULDER, TYPE B	HOT-MIX ASPHALT SHOULDERS	SHOULDER RUMBLE STRIPS, 16 INCH	
			POUND	SQ YD	TON	TON	TON	TON	TON	FOOT		
<b>WB I-72: SN 086-0041</b>												
642+78	-	644+33	155	24	186		35		23		310	
642+78	LT	644+52	LT	174	10	87				17		
642+78	RT	644+50	RT	172	8	69				13		
642+78	-	643+36	58	42		271						
643+36	-	644+33	97	42	204			29				
644+40	LT	644+52	LT	12	10	6		3				
644+38	RT	644+50	RT	12	8	5		2				
645+81	LT	646+00	LT	19	10	10		2				
645+81	RT	646+00	RT	19	6	6		1				
646+00	-	646+87	87	40	174			16				
646+87	-	647+55	68	40		303						
646+00	-	647+55	155	24	186		35		23		310	
645+81	LT	647+55	LT	174	10	87				17		
645+81	RT	647+55	RT	174	6	53				10		
<b>SN 086-0041 TOTAL</b>					<b>1073</b>		<b>70</b>	<b>53</b>	<b>46</b>	<b>57</b>	<b>620</b>	
<b>WB I-72: SN 086-0043</b>												
41+84	-	44+14	230	24	276		52		12		460	
41+84	LT	44+14	LT	230	10	115				22		
41+84	RT	44+14	RT	230	6	69				13		
41+84	-	42+82	98	40		436						
42+82	-	44+14	132	40	264			30				
46+62	-	47+88	126	40	252			16				
47+88	-	48+92	104	40		463						
46+62	-	48+92	230	24	276		52		12		460	
46+62	LT	48+92	LT	230	10	115				22		
46+62	RT	48+92	RT	230	6	69				13		
<b>SN 086-0043 TOTAL</b>					<b>1436</b>		<b>104</b>	<b>46</b>	<b>24</b>	<b>70</b>	<b>920</b>	
<b>EB I-72: SN 086-0040</b>												
143+54	-	145+09	155	24	186		35		23		310	
143+54	LT	145+33	LT	179	8	72				14		
143+54	RT	145+27	RT	173	10	87				17		
143+54	-	144+21	67	42		313						
144+21	-	145+09	88	42	185			16				
145+09	LT	145+33	LT	24	8	10		1				
145+09	RT	145+27	RT	18	10	9		1				
146+60	LT	146+77	LT	17	6	6		1				
146+56	RT	146+77	RT	21	10	11		1				
146+77	-	147+22	45	40	90			6				
147+22	-	148+03	81	40		360						
146+77	-	148+03	126	24	152		29		19		252	
146+60	LT	148+03	LT	143	6	43				9		
146+56	RT	148+03	RT	147	10	74				14		
<b>SN 086-0040 TOTAL</b>					<b>925</b>		<b>64</b>	<b>26</b>	<b>42</b>	<b>54</b>	<b>562</b>	
<b>EB I-72: SN 086-0042</b>												
41+94	-	44+15	221	24	266		50		11		442	
41+94	LT	44+15	LT	221	6	67				13		
41+94	RT	44+15	RT	221	10	111				21		
41+94	-	42+54	60	40		267						
42+54	-	44+15	161	40	322			38				
46+61	-	48+81	220	40	440			66				
48+81	-	49+62	81	40		360						
46+61	-	49+62	301	24	362		68		15		602	
46+61	LT	49+62	LT	301	6	91				17		
46+61	RT	49+62	RT	301	10	151				29		
<b>SN 086-0042 TOTAL</b>					<b>1810</b>		<b>118</b>	<b>104</b>	<b>26</b>	<b>80</b>	<b>1044</b>	
<b>TOTALS</b>					<b>5,244</b>		<b>2,773</b>	<b>356</b>	<b>229</b>	<b>138</b>	<b>261</b>	<b>3,146</b>

MODEL: Default  
 FILE: Mainfile\_pav.sld  
 PROJECT: D:\Projects\DOT\Documents\DOT\Office\Drawings\EB I-72\086-0040.dwg  
 PLOT DATE: 12/14/2022

USER NAME = Frank.Caraballo	DESIGNED -	REVISED -
PLOT SCALE = 100,0000' / 1 in.	DRAWN -	REVISED -
PLOT DATE = 12/14/2022	CHECKED -	REVISED -
	DATE -	REVISED -

**STATE OF ILLINOIS**  
**DEPARTMENT OF TRANSPORTATION**

SCHEDULES OF QUANTITIES			
SCALE:	SHEET	OF	SHEETS
	STA.	TO	STA.

F.A.I. RTE.	SECTION	COUNTY	TOTAL SHEETS	SHEET NO.
72	(86-8)BDR1,BJR1,BRR1,BP	SCOTT	45	7
CONTRACT NO. 72136				
ILLINOIS FED. AID PROJECT				

HMA SHOULDER REPLACEMENT FOR STAGE TRAFFIC							
LOCATION				WIDTH FOOT	35501316	X4401198	
STATION	TO	STATION	HOT-MIX ASPHALT BASE COURSE, 8"		HOT-MIX ASPHALT SURFACE REMOVAL, VARIABLE DEPTH		
					SQ YD	SQ YD	
<b>WB I-72 SN 086-0041</b>							
642+45	LT	-	644+52	LT	10	230.0	230.0
645+81	LT	-	648+48	LT	10	297.0	297.0
642+45	RT	-	644+50	RT	8	183.0	183.0
645+81	RT	-	648+48	RT	6	178.0	178.0
SN 086-0041 SUB-TOTAL						888.0	888.0
<b>WB I-72 SN 086-0043</b>							
41+30	LT	-	43+97	LT	10	297.0	297.0
46+79	LT	-	50+15	LT	10	374.0	374.0
41+30	RT	-	43+97	RT	6	178.0	178.0
47+02	RT	-	50+15	RT	6	209.0	209.0
SN 086-0043 SUB-TOTAL						1058.0	1058.0
<b>EB I-72 SN 086-0040</b>							
142+60	LT	-	145+33	LT	8	243.0	243.0
146+60	LT	-	148+55	LT	6	130.0	130.0
142+60	RT	-	145+27	RT	10	297.0	297.0
146+56	RT	-	148+55	RT	10	222.0	222.0
SN 086-0040 SUB-TOTAL						892.0	892.0
<b>EB I-72 SN 086-0042</b>							
40+60	LT	-	43+97	LT	6	225.0	225.0
46+79	LT	-	49+47	LT	6	179.0	179.0
40+60	RT	-	43+97	RT	10	375.0	375.0
46+79	RT	-	49+47	RT	10	298.0	298.0
SN 086-0042 SUB-TOTAL						1077.0	1077.0
<b>TOTALS</b>						<b>3915.0</b>	<b>3915.0</b>

TEMPORARY RAMPS							
LOCATION				DESCRIPTION	LENGTH FOOT	WIDTH FOOT	40600990
STATION	TO	STATION	TEMPORARY RAMP				
							SQ YD
				1:40 Taper Rate			
<b>WB I-72 SN 086-0041</b>							
644+17	-	644+32		MAINLINE	15	24	40
LT 644+17	-	644+51		SHOULDER	34	10	38
RT 644+17	-	644+52		SHOULDER	34	8	31
645+99	-	646+14		MAINLINE	15	24	40
LT 645+81	-	646+15		SHOULDER	34	10	38
RT 645+81	-	646+15		SHOULDER	34	6	23
SN 086-0041 SUB-TOTAL							210
<b>WB I-72 SN 086-0043</b>							
42+99	-	43+14		MAINLINE	15	24	40
LT 42+99	-	43+97		SHOULDER	98	10	109
RT 42+99	-	43+97		SHOULDER	98	6	66
47+61	-	47+76		MAINLINE	15	24	40
LT 46+79	-	47+76		SHOULDER	97	10	108
RT 46+79	-	47+76		SHOULDER	97	6	65
SN 086-0043 SUB-TOTAL							428
<b>EB I-72 SN 086-0040</b>							
144+94	-	145+09		MAINLINE	15	24	40
LT 144+94	-	145+09		SHOULDER	15	8	14
RT 144+94	-	145+09		SHOULDER	15	10	17
146+77	-	146+92		MAINLINE	15	24	40
LT 146+77	-	146+92		SHOULDER	15	6	10
RT 146+77	-	146+92		SHOULDER	15	10	17
SN 086-0040 SUB-TOTAL							138
<b>EB I-72 SN 086-0042</b>							
42+99	-	43+14		MAINLINE	15	24	40
LT 42+99	-	43+97		SHOULDER	98	6	66
RT 42+99	-	43+97		SHOULDER	98	10	109
47+61	-	47+76		MAINLINE	15	24	40
46+79	-	47+76		SHOULDER	97	8	87
46+79	-	47+76		SHOULDER	97	6	65
SN 086-0042 SUB-TOTAL							407
<b>TOTAL</b>							<b>1183</b>

INLETS TO BE ADJUSTED SCHEDULE								
LOCATION				WIDTH FOOT	6C600605	X6024503	Z0012500	
STATION	TO	STATION	CONCRETE CURB, TYPE B		INLETS TO BE ADJUSTED WITH NEW FRAME AND GRATE (SPECIAL)	CONCRETE CURB REPAIR		
					FOOT	FOOT	FOOT	
<b>WB I-72 SN 086-0043</b>								
43+97	LT	-	44+03	LT	10		1	6
43+97	RT	-	44+03	RT	8		1	6
46+72	LT	-	46+87	LT	10	15	1	
46+72	RT	-	46+87	RT	6	15	1	
SN 086-0043 SUB-TOTAL						30.0	4.0	12.0
<b>EB I-72 SN 086-0042</b>								
43+97	LT	-	44+12	LT	8	15	1	
43+97	RT	-	44+12	RT	10	15	1	
46+72	LT	-	46+78	LT	6		1	6
46+72	RT	-	46+78	RT	10		1	6
SN 086-0042 SUB-TOTAL						30.0	4.0	12.0
<b>TOTALS</b>						<b>60.0</b>	<b>8.0</b>	<b>24.0</b>

GUARDRAIL SCHEDULE					
LOCATION			63100085	X6320100	
STATION	TO	STATION	TRAFFIC BARRIER TERMINAL, TYPE 6	GUARDRAIL REMOVAL, SPECIAL	
			EACH	FOOT	
<b>WB I-72 SN 086-0041</b>					
644+31	LT	644+68	LT	1	37.5
645+65.0	LT	646+15.0	LT	1	50.0
644+28.5	RT	644+66.0	RT	1	37.5
645+64.0	RT	646+14.0	RT	1	50.0
SN 086-0041 SUB-TOTAL				4	175
<b>WB I-72 SN 086-0043</b>					
46+57.0	LT	47+07.0	LT	1	50.0
46+57.0	RT	47+07.0	RT	1	50.0
SN 086-0043 SUB-TOTAL				2	100
<b>EB I-72 SN 086-0040</b>					
144+99	LT	145+49	LT	1	50.0
145+04.5	RT	145+42.0	RT	1	50.0
SN 086-0040 SUB-TOTAL				2	100
<b>EB I-72 SN 086-0042</b>					
43+69.0	LT	44+19.0	LT	1	50.0
43+69.0	RT	44+19.0	RT	1	50.0
SN 086-0042 SUB-TOTAL				2	100
<b>TOTALS</b>				<b>10</b>	<b>475</b>

MODEL: P:\default...  
 FILE NAME: ...  
 PROJECT: ...  
 SHEET: ...

USER NAME = Frank.Caraballo	DESIGNED -	REVISED -
PLOT SCALE = 100,0000' / in.	DRAWN -	REVISED -
PLOT DATE = 12/14/2022	CHECKED -	REVISED -
	DATE -	REVISED -

**STATE OF ILLINOIS  
DEPARTMENT OF TRANSPORTATION**

**SCHEDULES OF QUANTITIES**

SCALE:	SHEET	OF	SHEETS	STA.	TO	STA.
--------	-------	----	--------	------	----	------

F.A.I. RTE.	SECTION	COUNTY	TOTAL SHEETS	SHEET NO.
72	(86-8)BDR1,BR1,BRR1,BP	SCOTT	45	8
			CONTRACT NO. 72136	
ILLINOIS FED. AID PROJECT				



BRIDGE APPROACH SHOULDERS												
LOCATION			LENGTH	WIDTH	48300300	61000115	61000335	66201120	Z0001495	X1400432	X6050700	
STATION	TO	STATION			PORTLAND CEMENT CONCRETE SHOULDERS 8"	TYPE E INLET BOX, STANDARD 610001	TYPE G INLET BOX, STANDARD 610001	CONCRETE SHOULDER CURB	BRIDGE APPROACH SHOULDER REMOVAL	REMOVE AND REINSTALL SHOULDER INLET DRAIN PIPE AND CONNECTION	REMOVE INLET BOX	
			FOOT	FOOT	SQ YD	EACH	EACH	FOOT	SQ YD	EACH	EACH	
<b>WB I-72 SN 086-0041</b>												
644+52	LT	-	644+67	LT	15	10	16.7			15	16.7	
644+50.0	RT	-	644+65	RT	15	8	13.3		1	15	13.3	1
645+68.0	LT	-	645+83	LT	15	10	16.7			15	16.7	
645+68.0	RT	-	645+83	RT	15	6	10.0		1	15	10.0	1
<i>SN 086-0041 SUB-TOTAL</i>							56.7	0.0	2.0	60.0	56.7	2.0
<b>EB I-72 SN 086-0040</b>												
145+33	LT	-	145+48	LT	15	8	13.3			15	13.3	
145+27.0	RT	-	145+42	RT	15	10	16.7	1		15	16.7	1
146+47.0	LT	-	146+62	LT	15	6	10.0			15	10.0	
146+43.0	RT	-	146+58	RT	15	10	16.7	1		15	16.7	1
<i>SN 086-0040 SUB-TOTAL</i>							56.7	2.0	0.0	60.0	56.7	2.0
<b>TOTALS</b>							<b>114.0</b>	<b>2.0</b>	<b>2.0</b>	<b>120.0</b>	<b>114.0</b>	<b>4.0</b>

PAVEMENT MARKING SCHEDULE												
LOCATION			DESCRIPTION	70300100	70300150	78009005	78100100	78300200	78300201			
STATION	TO	STATION		SHORT-TERM PAVEMENT MARKING	SHORT-TERM PAVEMENT MARKING REMOVAL	MODIFIED URETHANE PAVEMENT MARKING - LINE 5"	RAISED REFLECTIVE PAVEMENT MARKER	RAISED REFLECTIVE PAVEMENT MARKER REMOVAL	PAVEMENT MARKING REMOVAL GRINDING			
			TYPE	COLOR	FOOT	SQ FT	FOOT	EACH	EACH	SQ FT		
<b>WB I-72 SN 086-0041 &amp; 086-0043</b>												
642+78	LT	-	647+55	LT	SOLID EDGE LINE	WHITE	47.7	16	477		251	
642+78	CL	-	647+55	CL	SKIP DASH	WHITE	47.7	16	120	12	50	
642+78	RT	-	647+55	RT	SOLID EDGE LINE	YELLOW	47.7	16	477		251	
<i>SN 086-0041 TOTAL</i>							144.0	48	1074	12	552	
<i>STATION EQUATION STA 653+18.99 = STA 36+25.00</i>												
41+84	LT	-	48+92	LT	SOLID EDGE LINE	WHITE	70.8	24	708		368	
41+84	CL	-	48+92	CL	SKIP DASH	WHITE	70.8	24	177	18	74	
41+84	RT	-	48+92	RT	SOLID EDGE LINE	YELLOW	70.8	24	708		368	
<i>SN 086-0043 TOTAL</i>							213.0	72	1593	18	810	
<b>EB I-72 SN 086-0040 &amp; SN 086-0042</b>												
143+54	LT	-	148+03	LT	SOLID EDGE LINE	WHITE	44.9	15	449		247	
143+54	CL	-	148+03	CL	SKIP DASH	WHITE	44.9	15	113	11	47	
143+54	RT	-	148+03	RT	SOLID EDGE LINE	YELLOW	44.9	15	449		247	
<i>SN 086-0040 TOTAL</i>							135.0	45	1011	11	541	
<i>STATION EQUATION STA 153+93.08 = STA 154+02.17</i>												
41+94	LT	-	49+62	LT	SOLID EDGE LINE	WHITE	76.8	26	768		374	
41+94	CL	-	49+62	CL	SKIP DASH	WHITE	76.8	26	192	19	80	
41+94	RT	-	49+62	RT	SOLID EDGE LINE	YELLOW	76.8	26	768		374	
<i>SN 086-0042 TOTAL</i>							231.0	78	1728	19	828	
<b>TOTALS</b>							<b>723</b>	<b>243</b>	<b>5,406</b>	<b>60</b>	<b>60</b>	<b>2,731</b>

REV. - MS

MODEL: D:\default  
 FILE: M:\mhc\p\illinois\pavement\DOT\_offices\Dircc\B\Project\08672136\CADD\sub\_5310\CADD\sheet\08672136-ah-covez.dgn

USER NAME = Frank.Caraballo	DESIGNED -	REVISED -
	DRAWN -	REVISED -
PLOT SCALE = 100.0000' / in.	CHECKED -	REVISED -
PLOT DATE = 12/14/2022	DATE -	REVISED -

**STATE OF ILLINOIS  
DEPARTMENT OF TRANSPORTATION**

**SCHEDULES OF QUANTITIES**

SCALE: SHEET OF SHEETS STA. TO STA.

F.A.I. RTE.	SECTION	COUNTY	TOTAL SHEETS	SHEET NO.
72	(86-8)BDR1,BJR1,BRR1,BP	SCOTT	45	9
CONTRACT NO. 72136				
ILLINOIS FED. AID PROJECT				

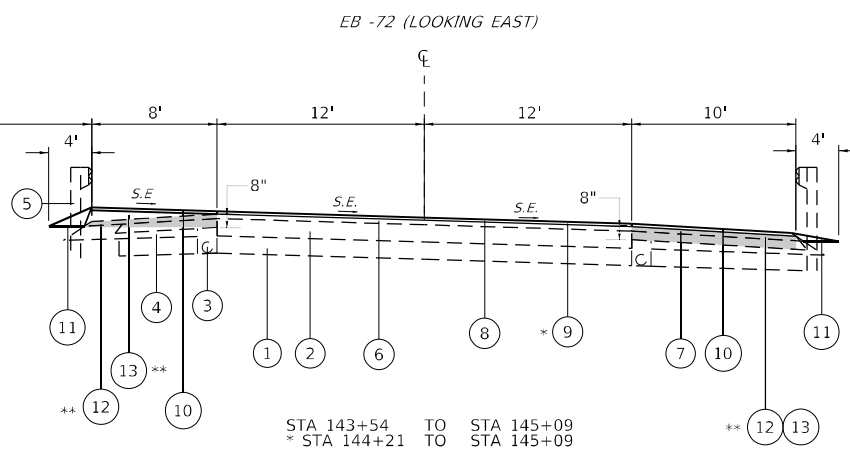
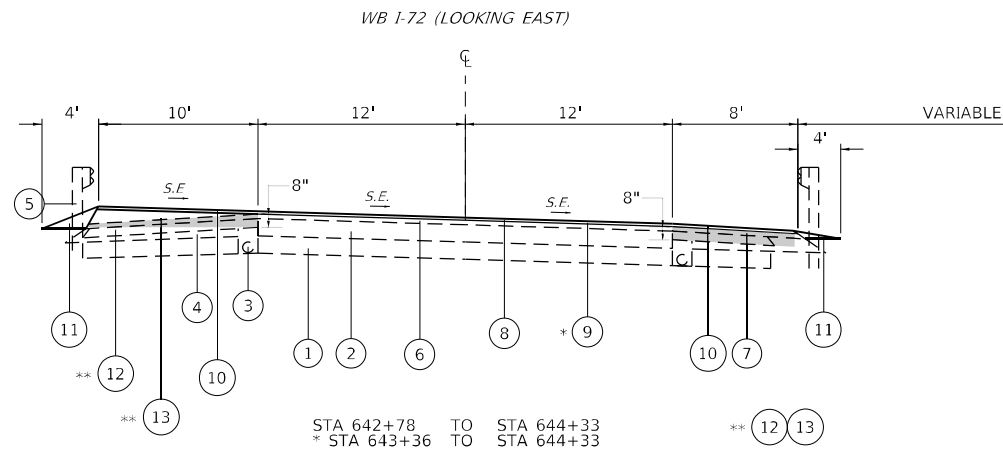

NOTES:

- \* DIP CORRECTION
- \*\* SHOULDER REPLACEMENT FOR STAGE TRAFFIC (SEE SCHEDULE OF QUANTITIES)

LEGEND:

SHOULDER RECONSTRUCTION & SUPER ELEVATION CORRECTION (SEE 12 13)

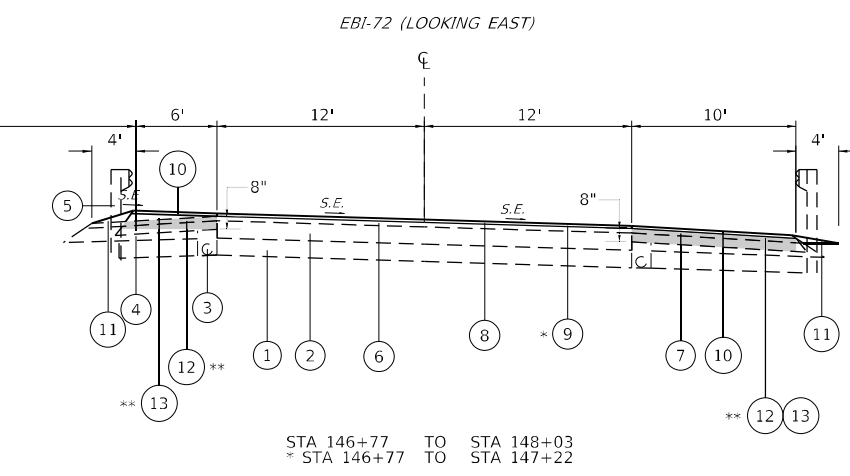
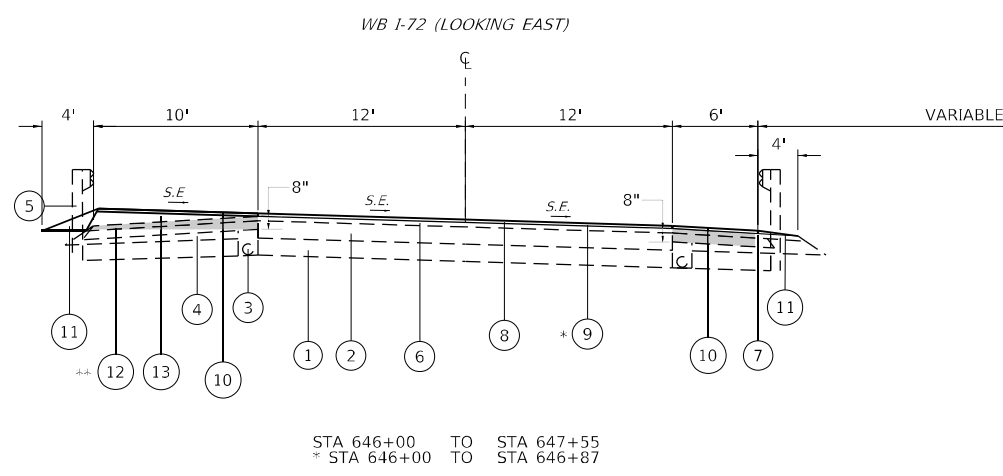

LEGEND

- 1 EXIST. LIME MODIFIED SOIL - 12"
- 2 EXIST. BITUMINOUS CONCRETE PAVEMENT, FULL DEPTH - 15" (13 1/2" BINDER, 1 1/2" SURFACE)
- 3 EXIST. PIPE UNDERDRAINS - 4"
- 4 EXIST. LIME MODIFIED SOIL / SUB-BASE GRANULAR MATERIAL
- 5 EXIST. STEEL PLATE BEAM GUARDRAIL
- 6 EXIST. POLYMERIZED BITUMINOUS CONCRETE SURFACE COURSE SUPERPAVE, MIXTURE D, N70 - 2"
- 7 EXIST. BITUMINOUS CONCRETE SURFACE COURSE CLASS I, TYPE 3, MIXTURE C (LOW ESAL) W/ RUMBLE STRIP
- 8 PROP. HMA SURFACE COURSE, IL-9.5, MIX "D", N70 - 1 1/2"
- 9 PROP. HMA BINDER COURSE, IL-9.5, MIX "D", N70 - VARIABLE DEPTH (\* DIP CORRECTION)
- 10 PROP. HMA SHOULDERS - 1 1/2"
- 11 PROP. AGGREGATE WEDGE SHOULDER, TYPE B
- 12 PROP. PAVED SHOULDER REMOVAL- VARIABLE DEPTH (SUPERELEVATION CORRECTION)
- 13 PROP. HMA BASE COURSE, 8" (SUPERELEVATION CORRECTION)

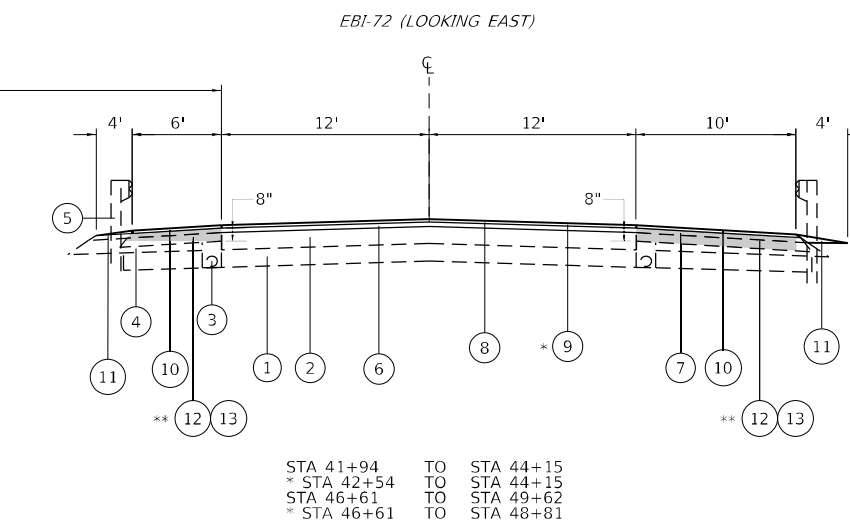
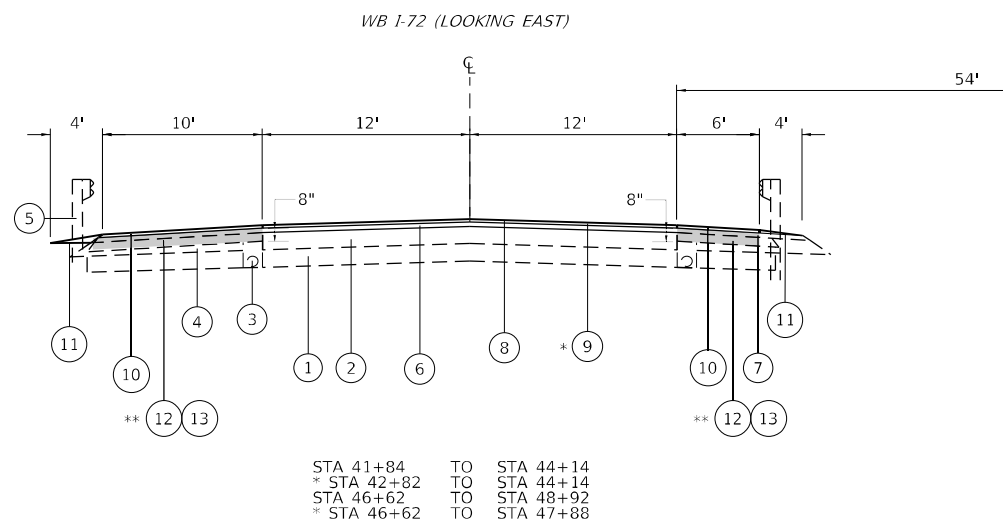

MODEL: Default  
 FILE: Mainfile.pxl  
 SUBJECT: new bench.mxd  
 PROJECT: I:\DOT\Documents\DOT Office\District 6\Project\0672136\CADD\DATA\_S5\0672136\CADD\Sheet\0672136-sh-curve.dgn  
 DATE: 12/14/2022

USER NAME = Frank.Caraballo	DESIGNED -	REVISED -
DRAWN -	REVISIONS -	REVISED -
PLOT SCALE = 100,0000 ' / in.	CHECKED -	REVISED -
PLOT DATE = 12/14/2022	DATE -	REVISED -

STATE OF ILLINOIS  
DEPARTMENT OF TRANSPORTATION

TYPICAL SECTIONS

SCALE: SHEET 1 OF 1 SHEETS STA. TO STA.

F.A.1 RTE.	SECTION	COUNTY	TOTAL SHEETS	SHEET NO.
72, I 72	*	SCOTT	45	10
CONTRACT NO. 72136				
ILLINOIS FED. AID PROJECT				

(86-8)BDR1,BJR1,BRR1,BP



EXIST. CURVE 462  
 PI STA. = 634+78.80  
 $\Delta = 20^\circ 55' 55''$  (RT)  
 $D = 0^\circ 48' 00''$   
 $R = 7,162.53'$   
 $T = 1,323.10'$   
 $L = 2,616.70'$   
 $E = 121.18'$   
 $e =$  \_\_\_\_\_  
 T.R. = \_\_\_\_\_  
 S.E. RUN = \_\_\_\_\_  
 P.C. STA. = 621+55.70  
 P.T. STA. = 647+72.41

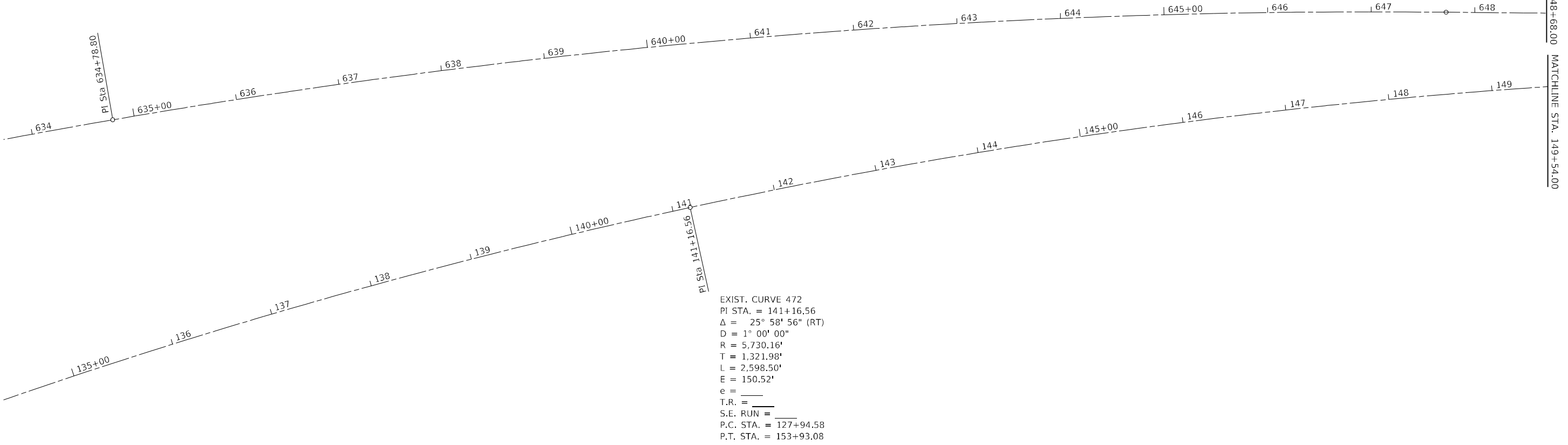

EXIST. CURVE 472  
 PI STA. = 141+16.56  
 $\Delta = 25^\circ 58' 56''$  (RT)  
 $D = 1^\circ 00' 00''$   
 $R = 5,730.16'$   
 $T = 1,321.98'$   
 $L = 2,598.50'$   
 $E = 150.52'$   
 $e =$  \_\_\_\_\_  
 T.R. = \_\_\_\_\_  
 S.E. RUN = \_\_\_\_\_  
 P.C. STA. = 127+94.58  
 P.T. STA. = 153+93.08

Benchmark	NAVD88 Elevation	Description
BM RK-49	442.853	Chslid [] E edge round conc drop inlet foundation cl median I-72 @ sta 64+02.0; 0.8' Lt
BM RK-50	449.198	Chslid [] top NE parapet wall str # 086-0043 WBL I-72 @ sta 46+70.4; 62.1' Lt
BM RK-51	449.317	Chslid [] top NW parapet wall str # 086-0042 EBL I-72 @ sta 44+06.2; 19.9' Rt
BM RK-52	446.55	Chslid [] SW wingwall str # 086-0041 WBL I-72 @ sta 644+62.9; 8.0' Rt
BM RK-53	446.932	Chslid [] NW wingwall str # 086-0040 EBL I-72 @ sta 644+59.9; 101.4' Rt
BM 618+85 N WBL	464.365	Star drill N side E end Valley City Eagle Bridge @ sta 618+85.0; 6.6' Rt
BM 618+85 S WBL	464.363	Star drill at station 618+85 S side E end WBL Valley City Eagle Bridge
BM EBL ABUT N	466.250	Star drill at cl about N side E end EBL Valley City Eagle Bridge @ sta 118+63.4; 6.9' Rt
BM EBL ABUT S	466.269	Star drill at cl about S side E end EBL Valley City Eagle Bridge @ sta 118+63.9; 34.6' Rt

MODEL: Default  
 FILE: \\mfrs-pw-bentley.com\P\IN\DOT\Documents\DOT\_Offices\District\_6\Projects\0672136\CADDData\_S5\0672136\CADDData\_S5\0672136\Sheet-Curve.dgn

USER NAME = Frank.Caraballo	DESIGNED -	REVISED -
DRAWN -	REVISED -	
PLOT SCALE = 100,0000' / in.	CHECKED -	REVISED -
PLOT DATE = 12/14/2022	DATE -	REVISED -

**STATE OF ILLINOIS  
 DEPARTMENT OF TRANSPORTATION**

**ALIGNMENT & ROAD LAYOUT LOCATION**

SCALE: SHEET OF SHEETS STA. TO STA.

F.A.I. RTE.	SECTION	COUNTY	TOTAL SHEETS	SHEET NO.
72	(86-8)BDR1,BJR1,BRR1,BP	SCOTT	45	11
CONTRACT NO. 72136				
ILLINOIS FED. AID PROJECT				

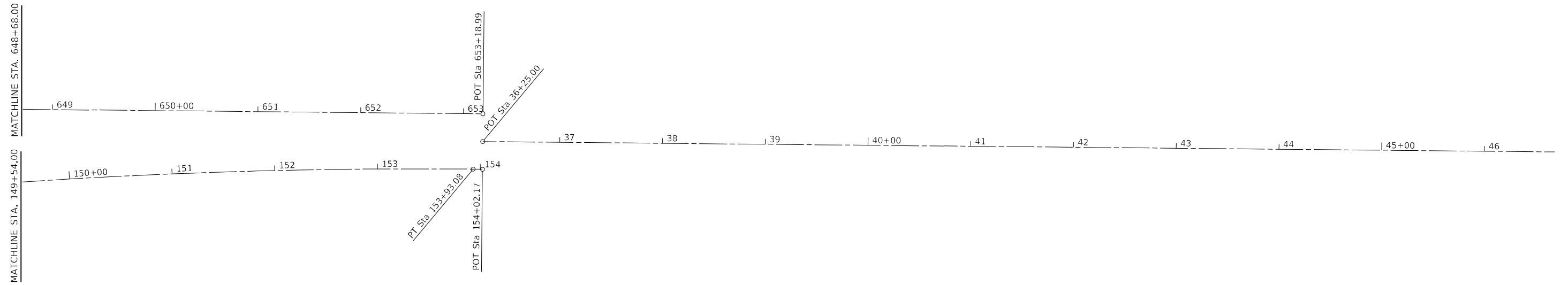

Benchmark	NAVD88 Elevation	Description
BM RK-49	442.853	Chsld [] E edge round conc drop inlet foundation cl median I-72 @ sta 64+02.0; 0.8' Lt
BM RK-50	449.198	Chsld [] top NE parapet wall str # 086-0043 WBL I-72 @ sta 46+70.4; 62.1' Lt
BM RK-51	449.317	Chsld [] top NW parapet wall str # 086-0042 EBL I-72 @ sta 44+06.2; 19.9' Rt
BM RK-52	446.55	Chsld [] SW wingwall str # 086-0041 WBL I-72 @ sta 644+62.9; 8.0' Rt
BM RK-53	446.932	Chsld [] NW wingwall str # 086-0040 EBL I-72 @ sta 644+59.9; 101.4' Rt
BM 618+85 N WBL	464.365	Star drill N side E end Valley City Eagle Bridge @ sta 618+85.0; 6.6' Rt
BM 618+85 S WBL	464.363	Star drill at station 618+85 S side E end WBL Valley City Eagle Bridge
BM EBL ABUT N	466.250	Star drill at cl abut N side E end EBL Valley City Eagle Bridge @ sta 118+63.4; 6.9' Rt
BM EBL ABUT S	466.269	Star drill at cl abut S side E end EBL Valley City Eagle Bridge @ sta 118+63.9; 34.6' Rt

MODEL: Default  
 FILE: Mainfile.pxl  
 SUBJECT: raw\_benchmark.com  
 PLOT DATE: 12/14/2022

USER NAME = Frank.Caraballo	DESIGNED -	REVISED -
PLOT SCALE = 100,0000' / in.	DRAWN -	REVISED -
PLOT DATE = 12/14/2022	CHECKED -	REVISED -
	DATE -	REVISED -

**STATE OF ILLINOIS  
DEPARTMENT OF TRANSPORTATION**

**ALIGNMENT & ROAD LAYOUT LOCATION**

SCALE: SHEET OF SHEETS STA. TO STA.

F.A.I. RTE.	SECTION	COUNTY	TOTAL SHEETS	SHEET NO.
72	(86-8)BDR1,BJR1,BRR1,BP	SCOTT	45	12
ILLINOIS FED. AID PROJECT			CONTRACT NO. 72136	

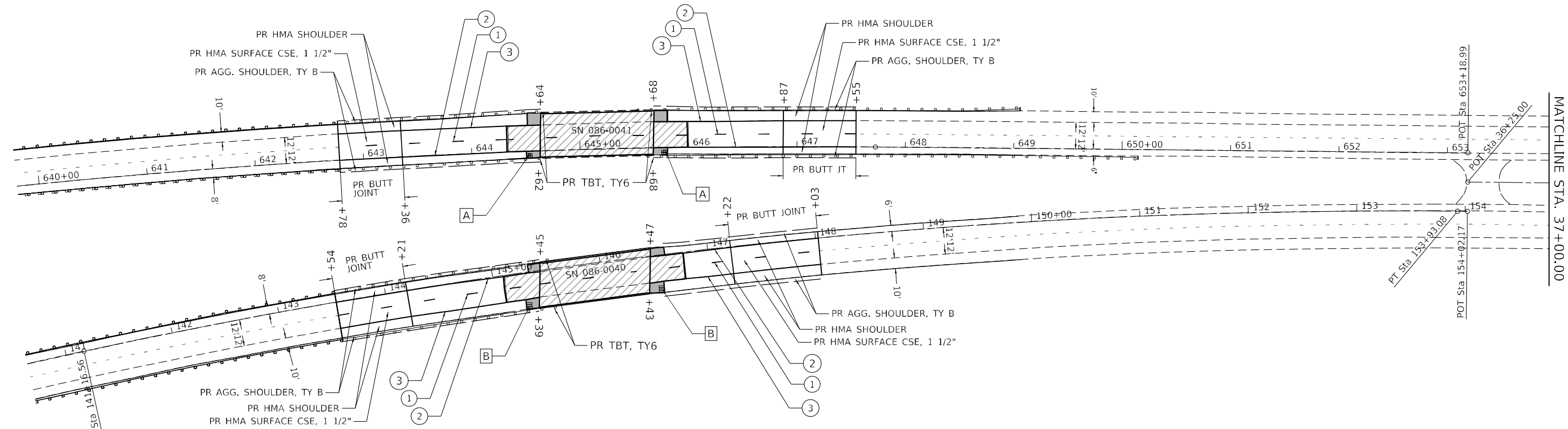

EXIST. CURVE 472  
 PI STA. = 141+16.56  
 $\Delta = 25^\circ 58' 56''$  (RT)  
 $D = 1^\circ 00' 00''$   
 $R = 5,730.16'$   
 $T = 1,321.98'$   
 $L = 2,598.50'$   
 $E = 150.52'$   
 $e = \text{---}$   
 $T.R. = \text{---}$   
 $S.E. \text{ RUN} = \text{---}$   
 $P.C. \text{ STA.} = 127+94.58$   
 $P.T. \text{ STA.} = 153+93.08$

**LEGEND**

- PR BRIDGE APPROACH REMOVAL & PR PCC SHOULDERS, 8" WITH CONCRETE SHOULDER CURB
- PR HYDROSCARIFICATION WITH MICROSILICA OVERLAY (SEE BRIDGE PLANS)
- PR MODIFIED URETHANE PAVEMENT MARKING, 5" (30' SKIP, 10' DASH) (SOLD WHITE)
- PR MODIFIED URETHANE PAVEMENT MARKING, LINE 5" (SOLID YELLOW)
- PR MODIFIED URETHANE PAVEMENT MARKING, LINE 5" (SOLID WHITE)
- PR TYPE G INLET BOX & REMOVE INLET BOX
- PR TYPE E INLET BOX & REMOVE EX INLET BOX

MODEL: Default  
 FILE: Mainfile.pdw  
 PROJECT: C:\Users\paw.bear@state.il.gov\Documents\DOT Office\District 6\Project\0672136\CADD\data\_55\0672136\CADD\data\_55\0672136\sheet\_472.dwg

USER NAME = Frank.Caraballo	DESIGNED -	REVISED -
PLOT SCALE = 100,0000 ' / in.	DRAWN -	REVISED -
PLOT DATE = 12/14/2022	CHECKED -	REVISED -
	DATE -	REVISED -

**STATE OF ILLINOIS  
DEPARTMENT OF TRANSPORTATION**

**PLAN  
WB /EB I-72**

SCALE: SHEET OF SHEETS STA. TO STA.

F.A.I. RTE.	SECTION	COUNTY	TOTAL SHEETS	SHEET NO.
72	(86-8)BDR1,BJR1,BRR1,BP	SCOTT	45	13
CONTRACT NO. 72136				
ILLINOIS FED. AID PROJECT				

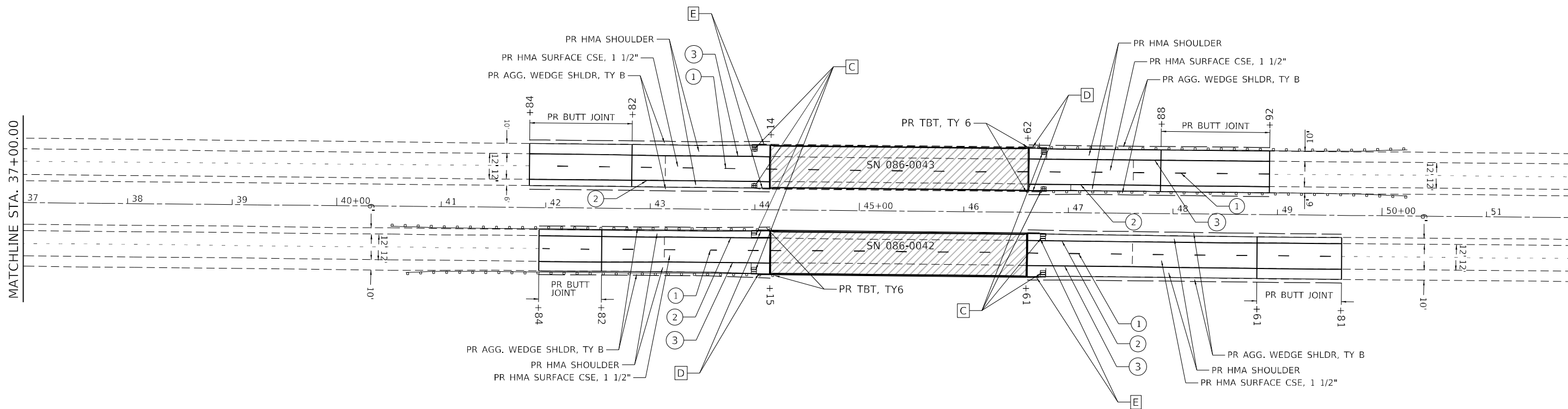

**LEGEND**

- PR HYDROSCARIFICATION WITH MICROSILICA OVERLAY (SEE BRIDGE PLANS)
- PR MODIFIED URETHANE PAVEMENT MARKING, 5" (30' SKIP, 10' DASH) (SOLID WHITE)
- PR MODIFIED URETHANE PAVEMENT MARKING, LINE 5" (SOLID YELLOW)
- PR MODIFIED URETHANE PAVEMENT MARKING, LINE 5" (SOLID WHITE)
- INLETS TO BE ADJUSTED WITH NEW FRAME & GRATES (SPECIAL)
- PR CONC CURB, TYPE B
- PR CONC. CURB REPAIR

**NOTE**

\* SN 086-0042 AND SN 086-0043: BRIDGE APPROACH PAVEMENTS AND APPROACH SHOULDERS TO BE OVERLAID WITH HMA SURFACE COURSE AND HMA SHOULDER, RESPECTIVELY.

MODEL: Default  
 FILE: Mainfile.pia  
 SUBJECT: new bench.mxd  
 PROJECT: I:\DOT\Documents\DOT Office\District 6\Project\0672136\CADD\data\_S5\0672136\CADD\data\_S5\0672136\sheet-4-bn.dgn

USER NAME = Frank.Caraballo	DESIGNED -	REVISED -
PLOT SCALE = 100,0000' / in.	DRAWN -	REVISED -
PLOT DATE = 12/14/2022	CHECKED -	REVISED -
	DATE -	REVISED -

**STATE OF ILLINOIS  
DEPARTMENT OF TRANSPORTATION**

<b>PLAN</b>			
<b>WB /EB I-72</b>			
SCALE:	SHEET	OF	SHEETS
	STA.	TO	STA.

F.A.I. RTE.	SECTION	COUNTY	TOTAL SHEETS	SHEET NO.
72	(86-8)BDR1,BJR1,BRR1,BP	SCOTT	45	14
CONTRACT NO. 72136				
ILLINOIS FED. AID PROJECT				

### TRAFFIC CONTROL PRE-STAGE I

- REMOVE AND REPLACE SHOULDER FOR STAGE I AND STAGE II TRAFFIC USING STANDARD 701400 & 701401.  
\* SEE SHOULDER SUPERELEVATION TRANSITION DETAIL
- HIGHWAY STANDARDS USED:
  - 701400
  - 701401

### TRAFFIC CONTROL STAGE I

- INSTALL TRAFFIC CONTROL FOR STAGE I AND SHIFT TRAFFIC AS SHOWN AND USING THE APPLICABLE PORTIONS OF THE HIGHWAY STANDARDS USED.
- HIGHWAY STANDARDS USED:
  - 701400
  - 701402 (SPECIAL)
- TRAFFIC CONTROL DETAILS (SIGNS, PAVEMENT MARKINGS, ETC) NOT SHOWN IN THESE STAGE CONSTRUCTION DETAILS SHALL BE AS PER THE HIGHWAY STANDARDS LISTED IN NOTE #2.

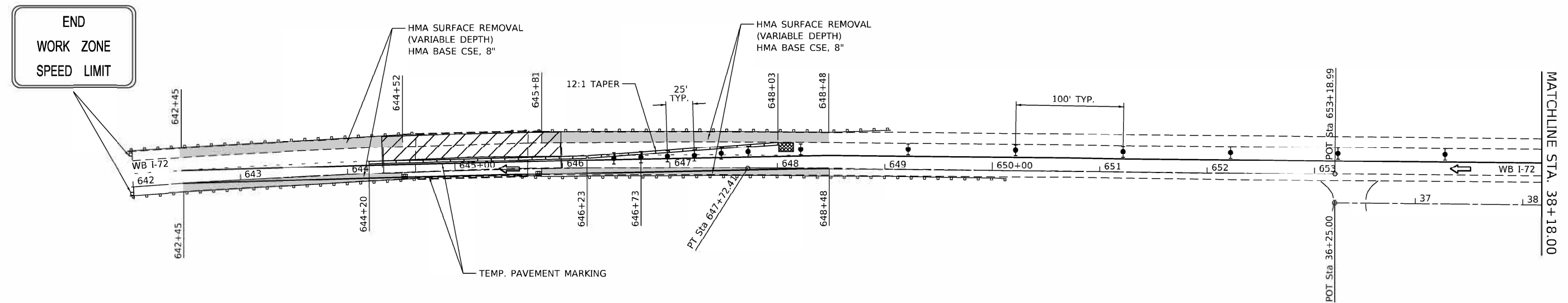

- ARROW BOARD
- TRAFFIC FLOW ARROW
- FULL DEPTH SHOULDER RECONSTRUCTION FOR STAGE TRAFFIC (PRE-STAGE I)
- WORK AREA
- SIGN
- DIRECTION INDICATOR BARRICADE WITH STEADY BURN MONODIRECTIONAL LIGHT
- TYPE II BARRICADE, DRUM, OR VERTICAL BARRICADE WITH STEADY BURN MONODIRECTIONAL LIGHT
- TEMPORARY IMPACT ATTENUATOR
- TEMPORARY CONCRETE BARRIER

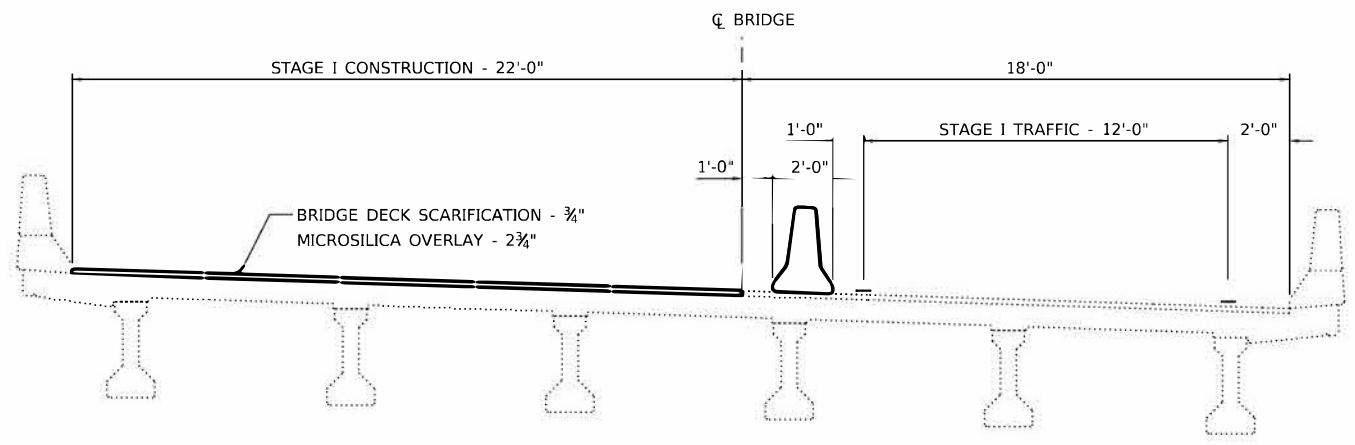

**STAGE I - SN 086-0041**  
(LOOKING EAST)

MODEL: Default  
 FILE: Mainfile.plt  
 PLOT DATE: 12/14/2022  
 PROJECT: ILLINOIS DEPARTMENT OF TRANSPORTATION  
 SHEET: 72 OF 15  
 CONTRACT: 72136

USER NAME = Frank.Caraballo	DESIGNED -	REVISED -
DRAWN -	REVISOR -	REVISION -
PLOT SCALE = 100.0000" / in.	CHECKED -	REVISOR -
PLOT DATE = 12/14/2022	DATE -	REVISION -

**STATE OF ILLINOIS  
DEPARTMENT OF TRANSPORTATION**

**STAGE I - WB I-72  
SN 086-0041**

SCALE: SHEET 1 OF 12 SHEETS STA. TO STA.

F.A.I. RTE.	SECTION	COUNTY	TOTAL SHEETS	SHEET NO.
72	(86-8)BDR1,BR1,BRR1,BP	SCOTT	45	15
ILLINOIS FED. AID PROJECT			CONTRACT NO. 72136	

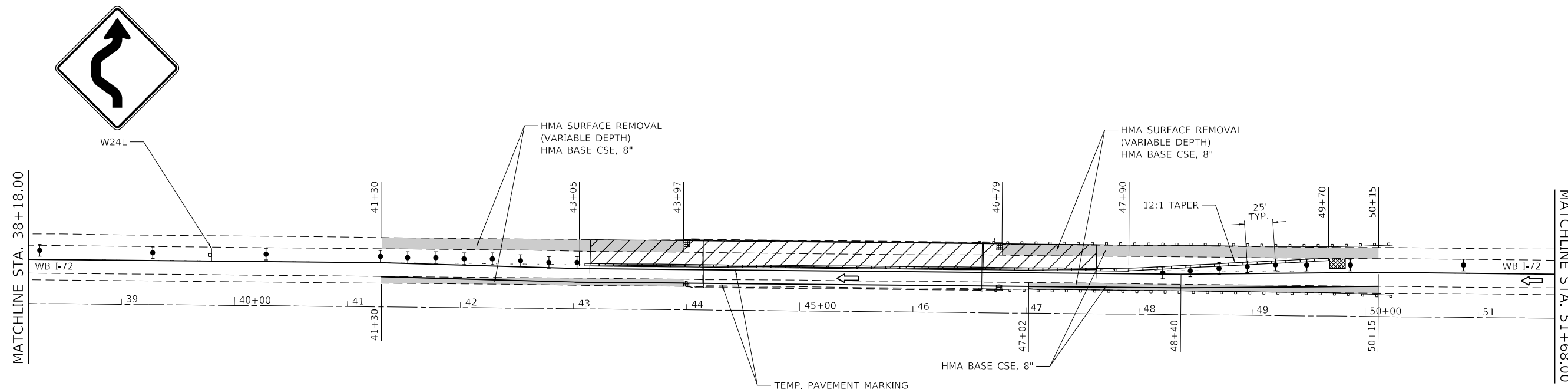

- ARROW BOARD
- TRAFFIC FLOW ARROW
- FULL DEPTH SHOULDER RECONSTRUCTION FOR STAGE TRAFFIC (PRE-STAGE I)
- WORK AREA
- SIGN
- DIRECTION INDICATOR BARRICADE WITH STEADY BURN MONODIRECTIONAL LIGHT
- TYPE II BARRICADE, DRUM, OR VERTICAL BARRICADE WITH STEADY BURN MONODIRECTIONAL LIGHT
- TEMPORARY IMPACT ATTENUATOR
- TEMPORARY CONCRETE BARRIER

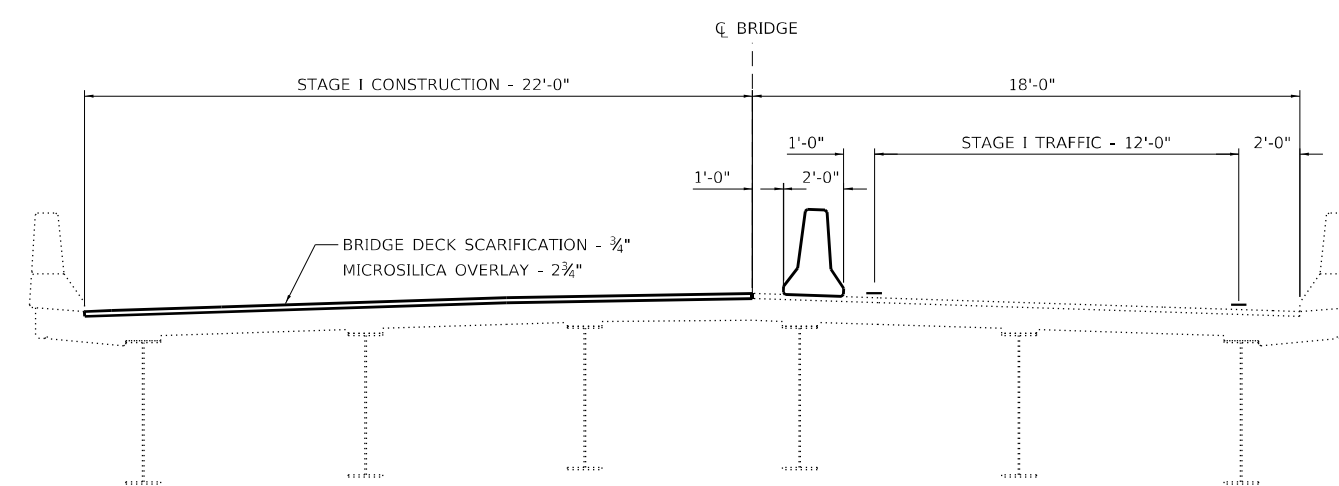

**STAGE II - SN 086-0043**  
(LOOKING EAST)

MODEL: Default  
 FILE: Mainfile.pxl  
 SUBJECT: new\_bentley.com\p\indot\documents\dot\_office\district\_6\project\0672136\cadd\data\_55\0\cadd\sheet\0672136\_sht5.dgn

USER NAME = Frank.Caraballo	DESIGNED -	REVISED -
DRAWN -	REVISOR -	
PLOT SCALE = 100,0000 ' / in.	CHECKED -	REVISOR -
PLOT DATE = 12/14/2022	DATE -	REVISOR -

**STATE OF ILLINOIS  
DEPARTMENT OF TRANSPORTATION**







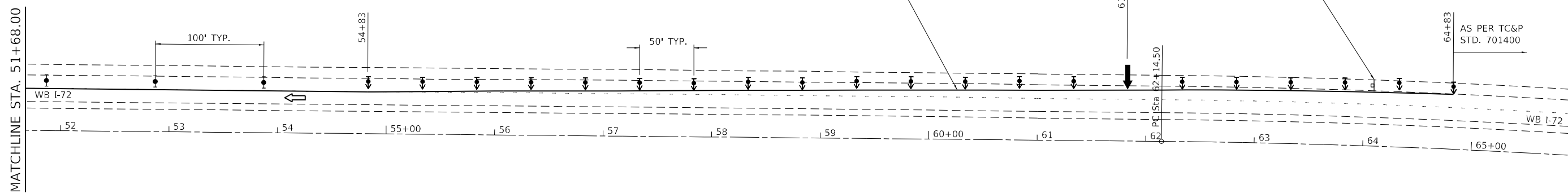

**STAGE I - WB I-72  
SN 086-0043**

SCALE: SHEET 2 OF 12 SHEETS STA. TO STA.

F.A.I. RTE.	SECTION	COUNTY	TOTAL SHEETS	SHEET NO.
72	(86-8)BDR1,BJR1,BRR1,BP	SCOTT	45	16
CONTRACT NO. 72136				
ILLINOIS		FED. AID PROJECT		





-  ARROW BOARD
-  TRAFFIC FLOW ARROW
-  FULL DEPTH SHOULDER RECONSTRUCTION FOR STAGE TRAFFIC (PRE-STAGE I)
-  WORK AREA
-  SIGN
-  DIRECTION INDICATOR BARRICADE WITH STEADY BURN MONODIRECTIONAL LIGHT
-  TYPE II BARRICADE, DRUM, OR VERTICAL BARRICADE WITH STEADY BURN MONODIRECTIONAL LIGHT
-  TEMPORARY IMPACT ATTENUATOR
-  TEMPORARY CONCRETE BARRIER

MODEL: Default  
 FILE: Mainfile.pxl  
 SUBJECT: new\_bentley.com  
 PLOT: PLOT Documents\DOT Office\District 6\Project\0672136\CADD\data\_S5\0\CADD\sheet0672136\_sht3.dgn

USER NAME = Frank.Caraballo	DESIGNED -	REVISED -
PLOT SCALE = 100,0000 ' / in.	DRAWN -	REVISED -
PLOT DATE = 12/14/2022	CHECKED -	REVISED -
	DATE -	REVISED -







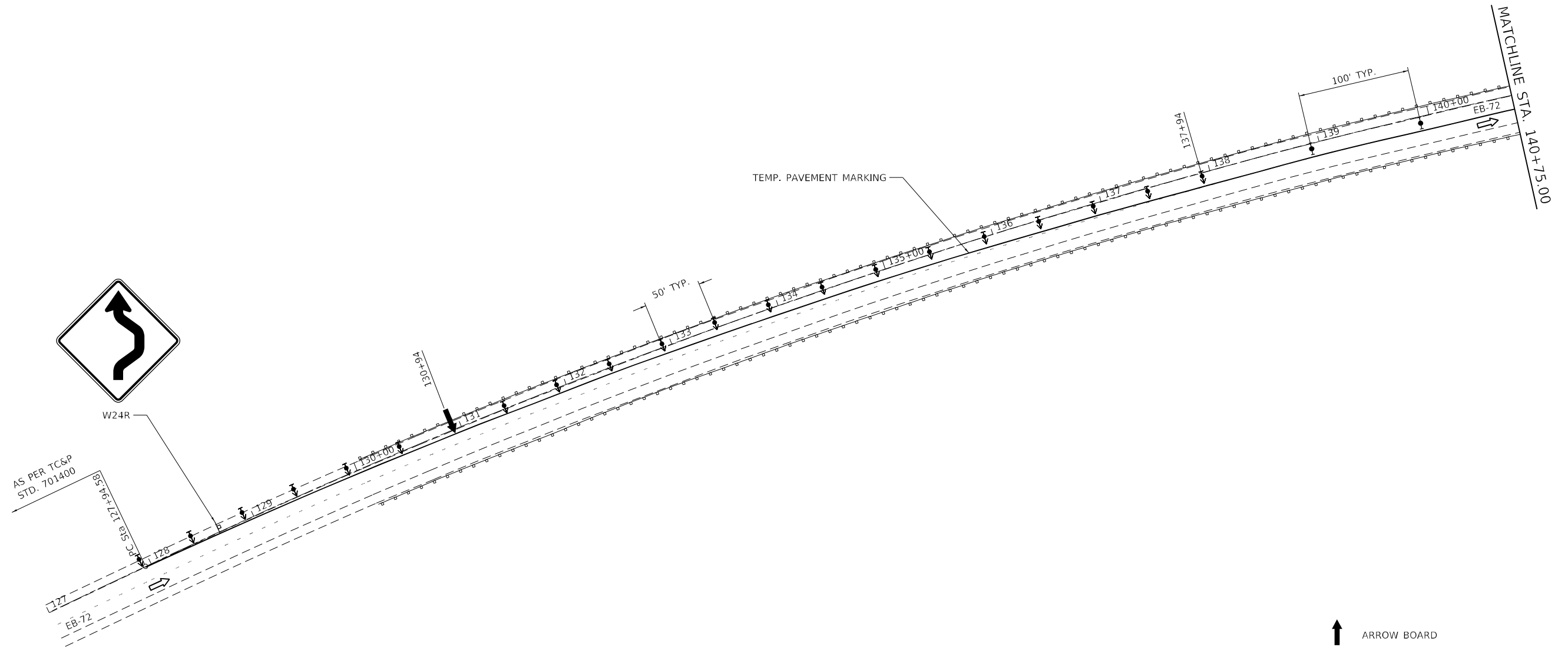

**STATE OF ILLINOIS  
DEPARTMENT OF TRANSPORTATION**

**STAGE I - WB I-72**

SCALE: SHEET 3 OF 12 SHEETS STA. TO STA.

F.A.I. RTE.	SECTION	COUNTY	TOTAL SHEETS	SHEET NO.
72	(86-8)BDR1,BJR1,BRR1,BP	SCOTT	45	17
CONTRACT NO. 72136				
ILLINOIS FED. AID PROJECT				



-  ARROW BOARD
-  TRAFFIC FLOW ARROW
-  FULL DEPTH SHOULDER RECONSTRUCTION (PRE-STAGE I)
-  WORK AREA
-  SIGN
-  DIRECTION INDICATOR BARRICADE WITH STEADY BURN MONODIRECTIONAL LIGHT
-  TYPE II BARRICADE, DRUM, OR VERTICAL BARRICADE WITH STEADY BURN MONODIRECTIONAL LIGHT
-  TEMPORARY IMPACT ATTENUATOR
-  TEMPORARY CONCRETE BARRIER

MODEL: Default  
 FILE: Mainfile.pia  
 SUBJECT: ew.bea@fy.com  
 P:\V\DOT\Documents\DOT\_offices\District\_6\Project\0672136\CADD\data\_55\0\0\CADD\sheet\0672136-eh-Sheeting.dgn

USER NAME = Frank.Caraballo	DESIGNED -	REVISED -
DRAWN -	DRAWN -	REVISED -
PLOT SCALE = 100,0000' / in.	CHECKED -	REVISED -
PLOT DATE = 12/14/2022	DATE -	REVISED -

**STATE OF ILLINOIS**  
**DEPARTMENT OF TRANSPORTATION**

<b>SCALE:</b>			
SHEET 4	OF 12 SHEETS	STA.	TO STA.

**STAGE I - EB I-72**

F.A.I. RTE.	SECTION	COUNTY	TOTAL SHEETS	SHEET NO.
72	(86-8)BDR1,BJR1,BRR1,BP	SCOTT	45	18
CONTRACT NO. 72136				
ILLINOIS FED. AID PROJECT				

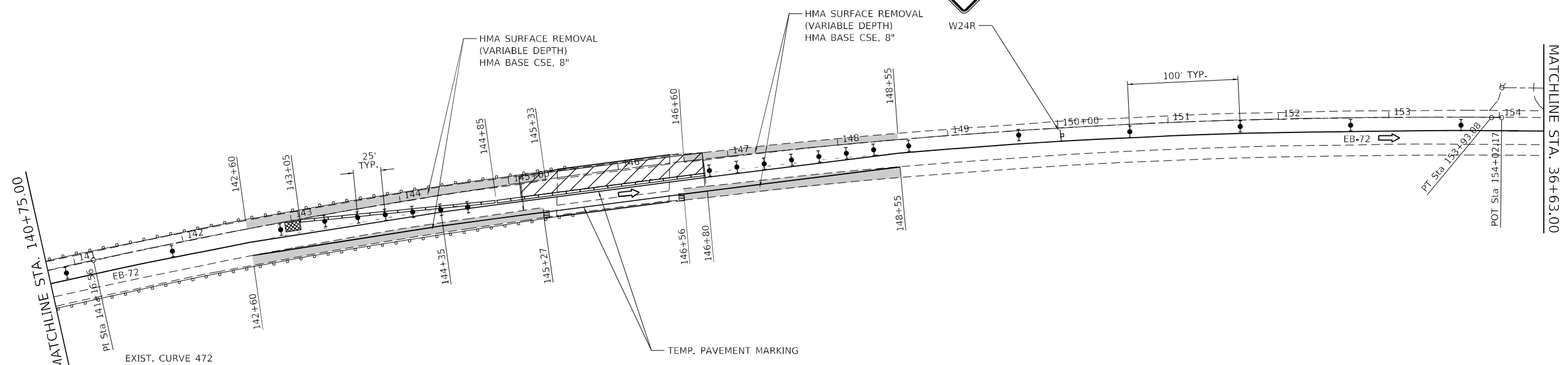
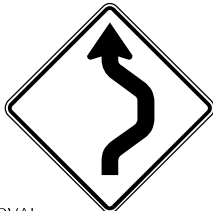

EXIST. CURVE 472  
 PI STA. = 141+16.56  
 $\Delta = 25^\circ 58' 56''$  (RT)  
 $D = 1^\circ 00' 00''$   
 $R = 5,730.16'$   
 $T = 1,321.98'$   
 $L = 2,598.50'$   
 $E = 150.52'$   
 $e = \underline{\hspace{1cm}}$   
 $T.R. = \underline{\hspace{1cm}}$   
 $S.E. RUN = \underline{\hspace{1cm}}$   
 $P.C. STA. = 127+94.58$   
 $P.T. STA. = 153+93.08$

- ARROW BOARD
- TRAFFIC FLOW ARROW
- FULL DEPTH SHOULDER RECONSTRUCTION (PRE-STAGE I)
- WORK AREA
- SIGN
- DIRECTION INDICATOR BARRICADE WITH STEADY BURN MONODIRECTIONAL LIGHT
- TYPE II BARRICADE, DRUM, OR VERTICAL BARRICADE WITH STEADY BURN MONODIRECTIONAL LIGHT
- TEMPORARY IMPACT ATTENUATOR
- TEMPORARY CONCRETE BARRIER

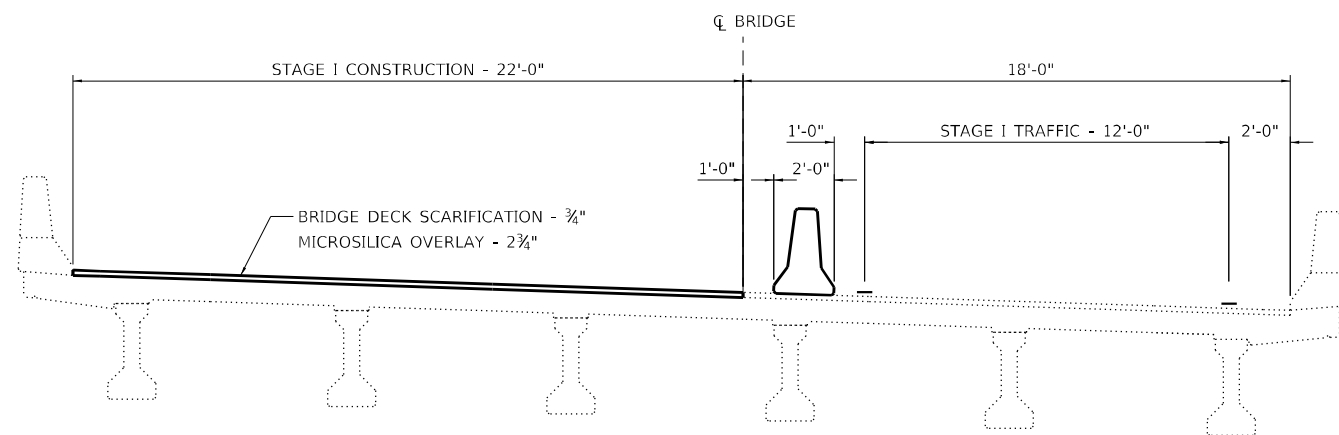

**STAGE I - SN 086-0040**  
 (LOOKING EAST)

MODEL: Default  
 FILE: Mainfile.pxl  
 PROJECT: D:\Projects\DOT\Office\District 6\Projects\0672136\CADD\data\_S5\0672136\CADD\Sheet\0672136-EB-I-Stage1.dgn

USER NAME = Frank,Caraballo	DESIGNED -	REVISED -
DRAWN -	REVISOR -	
PLOT SCALE = 100,0000' / in.	CHECKED -	REVISED -
PLOT DATE = 12/14/2022	DATE -	REVISED -

**STATE OF ILLINOIS**  
**DEPARTMENT OF TRANSPORTATION**

**STAGE I - EB I-72**  
**SN 086-0040**

SCALE: SHEET 5 OF 12 SHEETS STA. TO STA.

F.A.I. RTE.	SECTION	COUNTY	TOTAL SHEETS	SHEET NO.
72	(86-8)BDR1,BUR1,BRR1,BP	SCOTT	45	19
CONTRACT NO. 72136				
ILLINOIS FED. AID PROJECT				



END  
WORK ZONE  
SPEED LIMIT

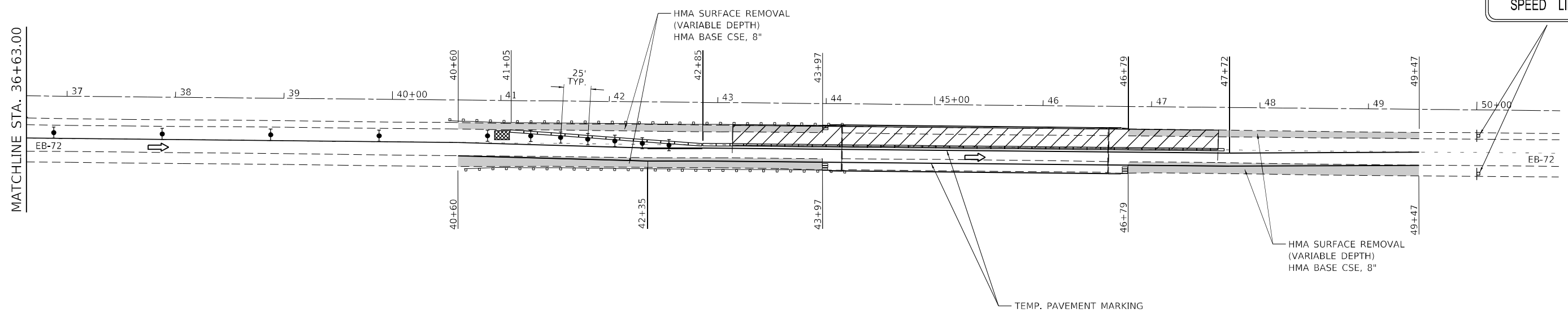

- ARROW BOARD
- TRAFFIC FLOW ARROW
- FULL DEPTH SHOULDER RECONSTRUCTION (PRE-STAGE I)
- WORK AREA
- SIGN
- DIRECTION INDICATOR BARRICADE WITH STEADY BURN MONODIRECTIONAL LIGHT
- TYPE II BARRICADE, DRUM, OR VERTICAL BARRICADE WITH STEADY BURN MONODIRECTIONAL LIGHT
- TEMPORARY IMPACT ATTENUATOR
- TEMPORARY CONCRETE BARRIER

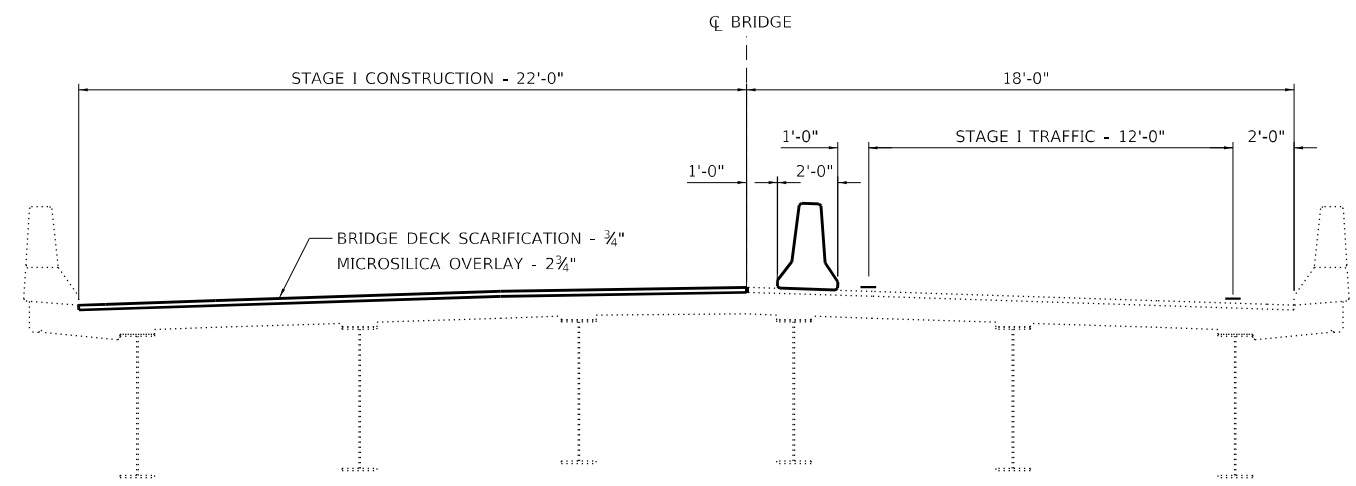

**STAGE I - SN 086-0042**  
(LOOKING EAST)

MODEL: Default  
 FILE: Mainfile.pxl  
 SUBJECT: pw\_bentley.com\pwwindows\Documents\DOT Office\District 6\Projects\0672136\CADD\data\_S5\0672136\sheet\StageI.dgn

USER NAME = Frank.Caraballo	DESIGNED -	REVISED -
	DRAWN -	REVISED -
PLOT SCALE = 100,0000' / in.	CHECKED -	REVISED -
PLOT DATE = 12/14/2022	DATE -	REVISED -

**STATE OF ILLINOIS  
DEPARTMENT OF TRANSPORTATION**

<b>STAGE I - EB I-72</b>			
<b>SN 086-0042</b>			
SCALE:	SHEET 6	OF 12 SHEETS	STA. TO STA.

F.A.I. RTE.	SECTION	COUNTY	TOTAL SHEETS	SHEET NO.
72	(86-8)BDR1,BJR1,BRR1,BP	SCOTT	45	20
CONTRACT NO. 72136				
ILLINOIS FED. AID PROJECT				

# TRAFFIC CONTROL STAGE II

1. RELOCATE TRAFFIC CONTROL FOR STAGE II AND SHIFT TRAFFIC AS SHOWN AND USING THE APPLICABLE PORTION OF THE HIGHWAY STANDARDS USED.
2. HIGHWAY STANDARDS USED:
  - 701400
  - 701402 (SPECIAL)
3. TRAFFIC CONTROL DETAILS (SIGNS, PAVEMENT MARKINGS, ETC) NOT SHOWN IN THESE STAGE CONSTRUCTION DETAILS SHALL BE AS PER HIGHWAY STANDARDS LISTED IN NOTE #2.

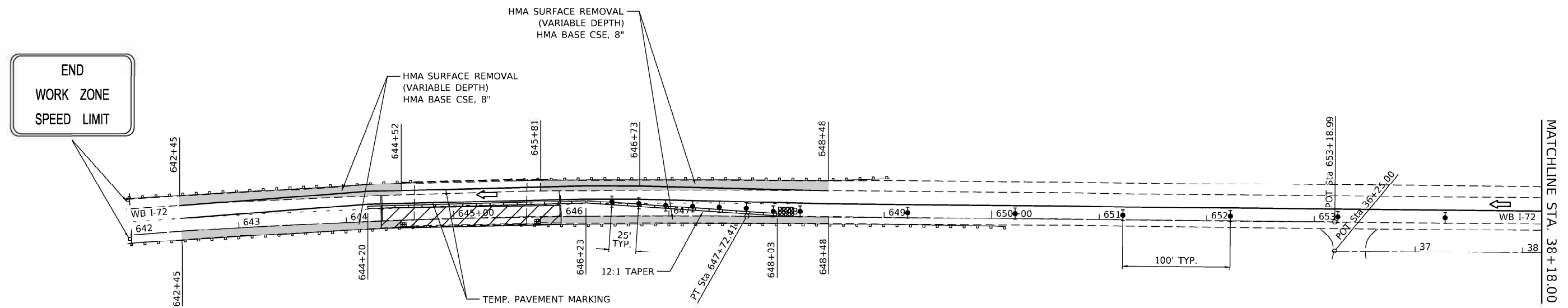

- ARROW BOARD
- TRAFFIC FLOW ARROW
- FULL DEPTH SHOULDER RECONSTRUCTION (PRE-STAGE I)
- WORK AREA
- SIGN
- DIRECTION INDICATOR BARRICADE WITH STEADY BURN MONODIRECTIONAL LIGHT
- TYPE II BARRICADE, DRUM, OR VERTICAL BARRICADE WITH STEADY BURN MONODIRECTIONAL LIGHT
- TEMPORARY IMPACT ATTENUATOR
- TEMPORARY CONCRETE BARRIER

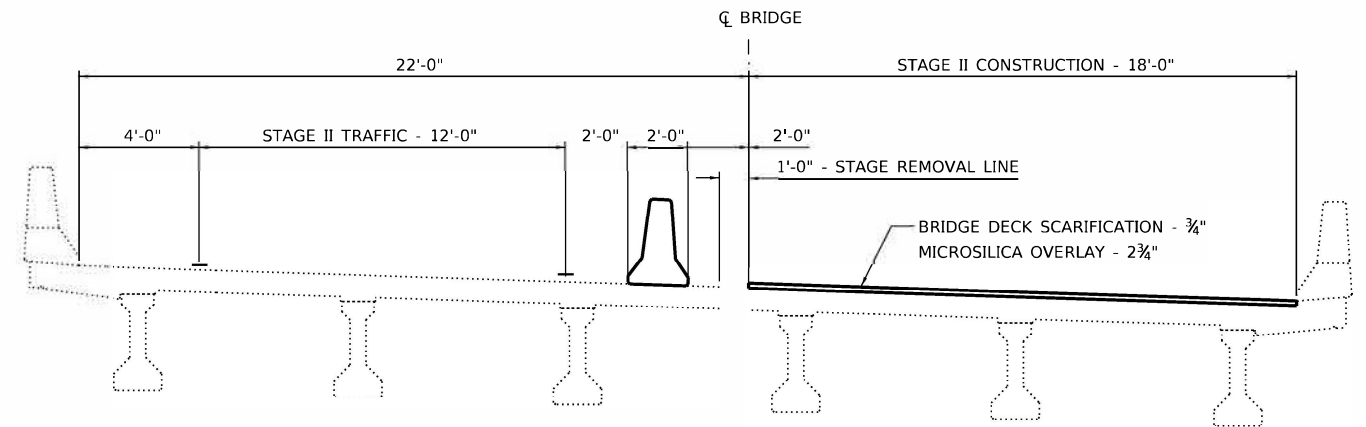

**STAGE II - SN 086-0041**  
(LOOKING EAST)

MODEL: Default  
 FILE: Main: p:\1115042-pw-bentley.com\p1115042\Documents\DOT\_Offices\District\_8\Projects\08672136\CADD\Draw\_55108\CADDsheets\08672136-sht-72136.dgn

USER NAME = Frank.Caraballo	DESIGNED -	REVISED -
DRAWN -	REVISIONS -	
PLOT SCALE = 100.0000" / in.	CHECKED -	REVISED -
PLOT DATE = 12/14/2022	DATE -	REVISED -

**STATE OF ILLINOIS  
DEPARTMENT OF TRANSPORTATION**

**STAGE II - WB I-72  
SN 086-0041**

SCALE: SHEET 7 OF 12 SHEETS STA. TO STA.

F.A.I. RTE.	SECTION	COUNTY	TOTAL SHEETS	SHEET NO.
72	(86-8)BDR1,BJR1,BRR1,BP	SCOTT	45	21
CONTRACT NO. 72136			ILLINOIS FED. AID PROJECT	

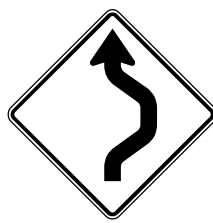
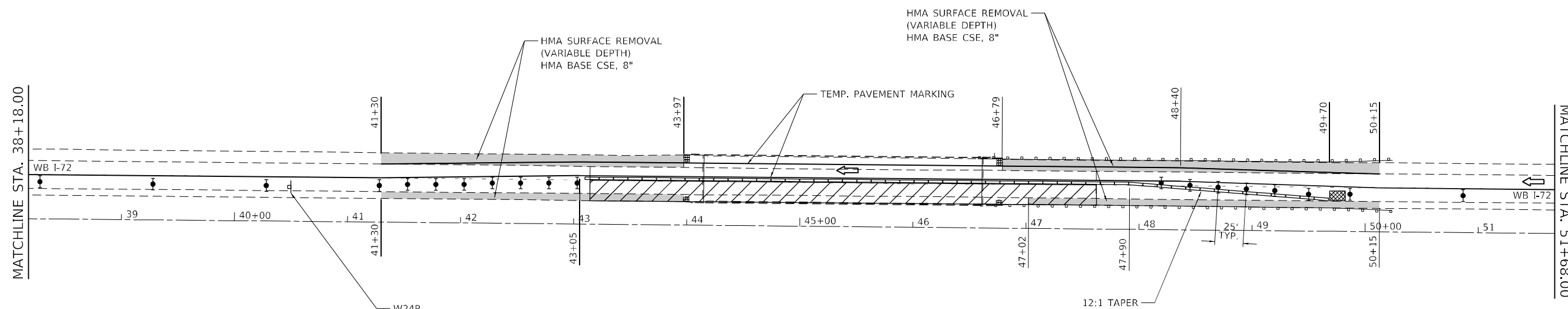

- ARROW BOARD
- TRAFFIC FLOW ARROW
- FULL DEPTH SHOULDER RECONSTRUCTION (PRE-STAGE I)
- WORK AREA
- SIGN
- DIRECTION INDICATOR BARRICADE WITH STEADY BURN MONODIRECTIONAL LIGHT
- TYPE II BARRICADE, DRUM, OR VERTICAL BARRICADE WITH STEADY BURN MONODIRECTIONAL LIGHT
- TEMPORARY IMPACT ATTENUATOR
- TEMPORARY CONCRETE BARRIER

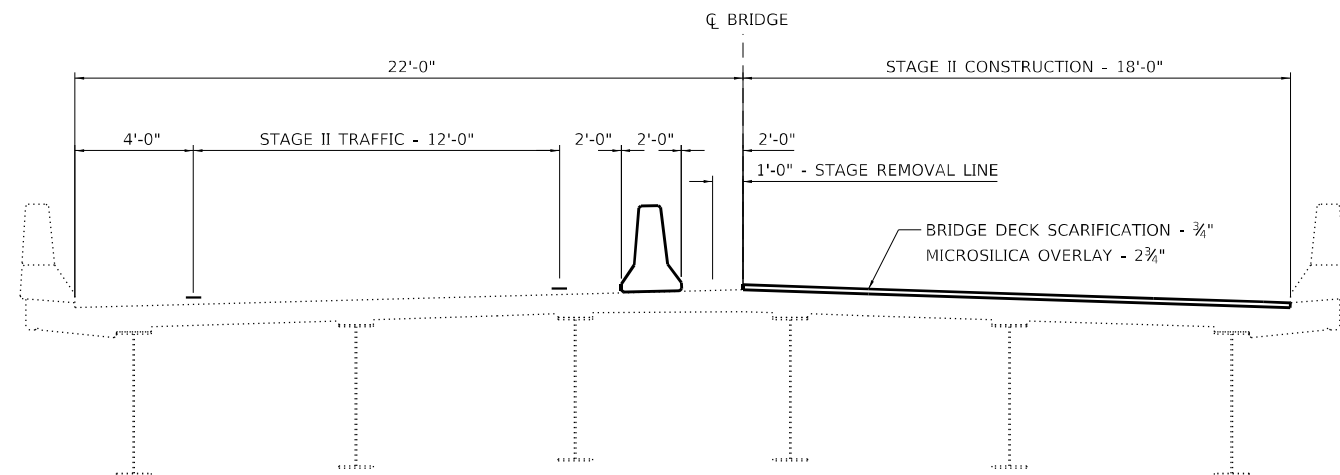

**STAGE II - SN 086-0043**  
(LOOKING EAST)

MODEL: Default  
 FILE: Mainfile.pxl  
 SUBJECT: new\_benefit.com  
 PLOT DATE: 12/14/2022







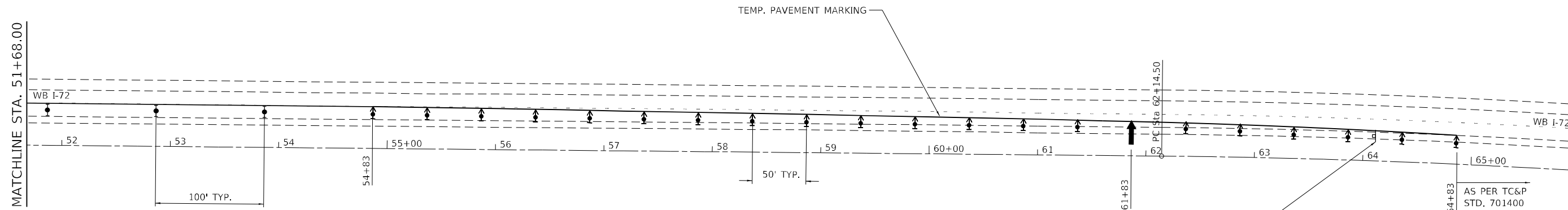

USER NAME = Frank.Caraballo	DESIGNED -	REVISED -
PLOT SCALE = 100,0000' / in.	DRAWN -	REVISIED -
PLOT DATE = 12/14/2022	CHECKED -	REVISIED -
	DATE -	REVISIED -

**STATE OF ILLINOIS  
DEPARTMENT OF TRANSPORTATION**

<b>STAGE II - WB I-72 SN 086-0043</b>			
SCALE:	SHEET 8	OF 12 SHEETS	STA. TO STA.

F.A.I. RTE.	SECTION	COUNTY	TOTAL SHEETS	SHEET NO.
72	(86-8)BDR1,BJR1,BRR1,BP	SCOTT	45	22
CONTRACT NO. 72136				
ILLINOIS FED. AID PROJECT				



-  ARROW BOARD
-  TRAFFIC FLOW ARROW
-  FULL DEPTH SHOULDER RECONSTRUCTION (PRE-STAGE I)
-  WORK AREA
-  SIGN
-  DIRECTION INDICATOR BARRICADE WITH STEADY BURN MONODIRECTIONAL LIGHT
-  TYPE II BARRICADE, DRUM, OR VERTICAL BARRICADE WITH STEADY BURN MONODIRECTIONAL LIGHT
-  TEMPORARY IMPACT ATTENUATOR
-  TEMPORARY CONCRETE BARRIER

MODEL: Default  
 FILE: \\na11c:\pwworkspace\beandefy.com\PIV\DOT\Documents\DOT\_Offices\District\_6\Project\0672136\CADD\data\_S5\0\CADD\sheet\0672136-sh2-StageII.dgn







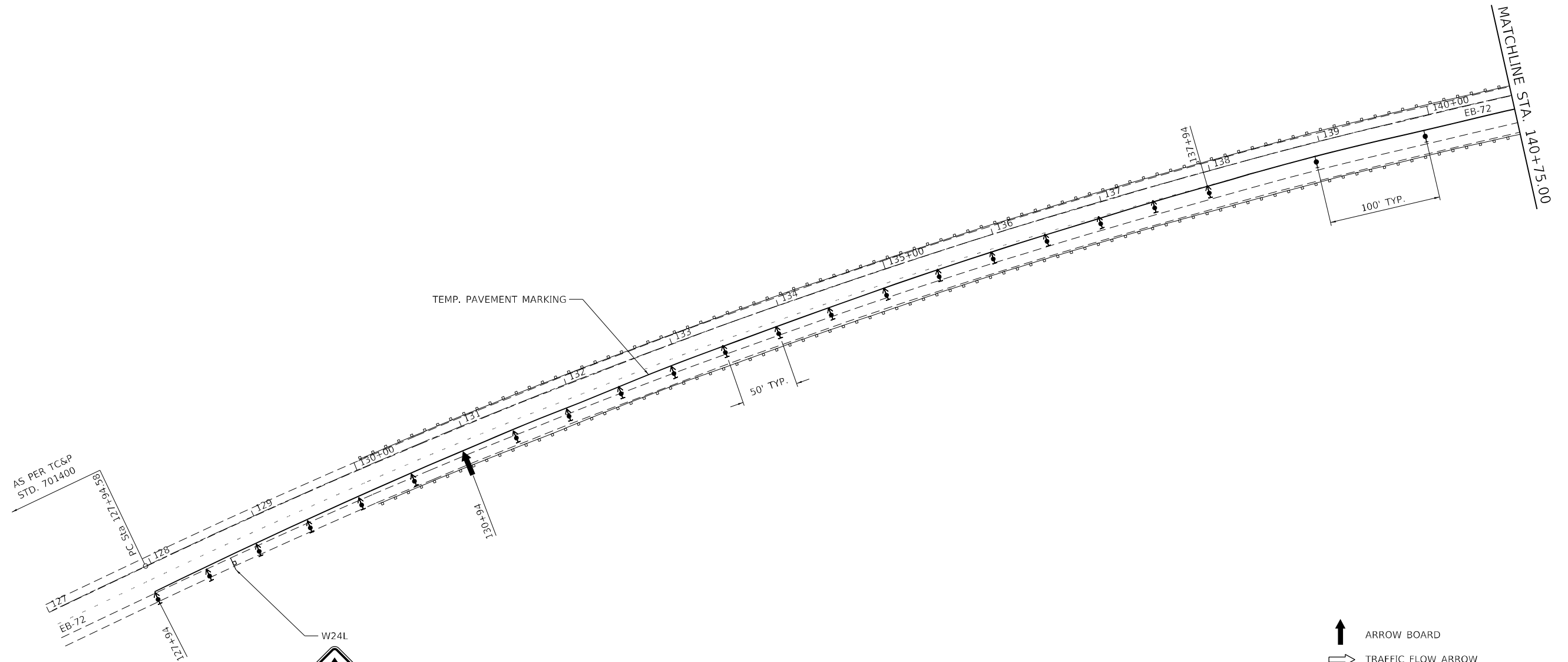

USER NAME = Frank.Caraballo	DESIGNED -	REVISED -
	DRAWN -	REVISED -
PLOT SCALE = 100,0000' / in.	CHECKED -	REVISED -
PLOT DATE = 12/14/2022	DATE -	REVISED -

**STATE OF ILLINOIS  
DEPARTMENT OF TRANSPORTATION**

<b>STAGE II - WB I-72</b>			
SCALE:	SHEET 9	OF 12 SHEETS	STA. TO STA.

F.A.I. RTE.	SECTION	COUNTY	TOTAL SHEETS	SHEET NO.
72	(86-8)BDR1,BJR1,BRR1,BP	SCOTT	45	23
CONTRACT NO. 72136				
ILLINOIS FED. AID PROJECT				



-  ARROW BOARD
-  TRAFFIC FLOW ARROW
-  FULL DEPTH SHOULDER RECONSTRUCTION (PRE-STAGE I)
-  WORK AREA
-  SIGN
-  DIRECTION INDICATOR BARRICADE WITH STEADY BURN MONODIRECTIONAL LIGHT
-  TYPE II BARRICADE, DRUM, OR VERTICAL BARRICADE WITH STEADY BURN MONODIRECTIONAL LIGHT
-  TEMPORARY IMPACT ATTENUATOR
-  TEMPORARY CONCRETE BARRIER

MODEL: Default  
 FILE NAME: p:\ultra\paw\benefy.com\PIV\DOT\Documents\DOT\_offices\District\_6\Project\0672136\CADD\data\_55\0672136\EB-72\136-eh-Stage10.dgn

USER NAME = Frank.Caraballo	DESIGNED -	REVISED -
DRAWN -	DRAWN -	REVISED -
PLOT SCALE = 100,0000' / in.	CHECKED -	REVISED -
PLOT DATE = 12/14/2022	DATE -	REVISED -

**STATE OF ILLINOIS  
DEPARTMENT OF TRANSPORTATION**

**STAGE II - EB I-72**

SCALE: SHEET 10 OF 12 SHEETS STA. TO STA.

F.A.I. RTE.	SECTION	COUNTY	TOTAL SHEETS	SHEET NO.
72	(86-8)BDR1,BJR1,BRR1,BP	SCOTT	45	24
CONTRACT NO. 72136				
ILLINOIS FED. AID PROJECT				



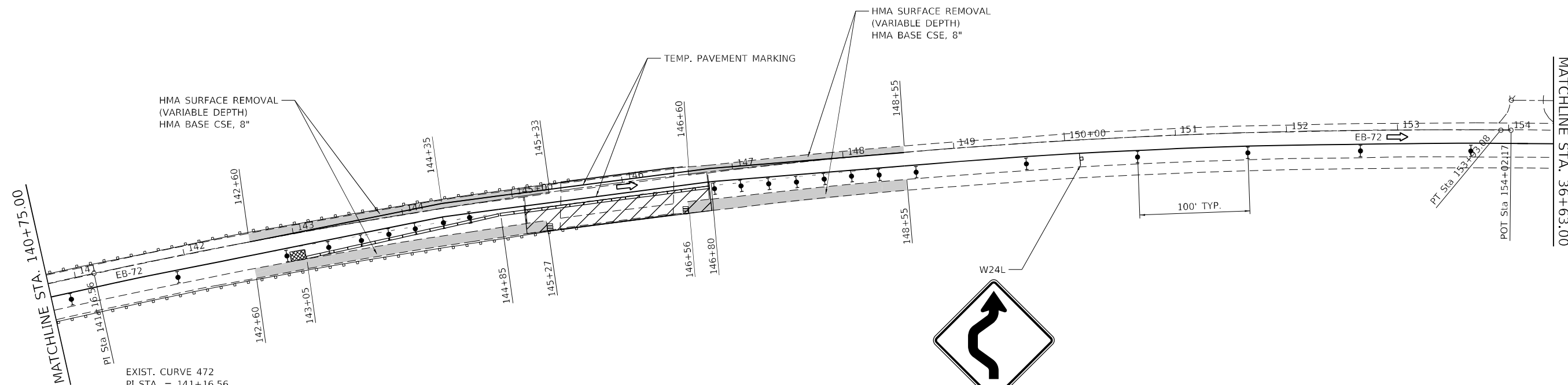

EXIST. CURVE 472  
 PI STA. = 141+16.56  
 $\Delta = 25^\circ 58' 56''$  (RT)  
 $D = 1^\circ 00' 00''$   
 $R = 5,730.16'$   
 $T = 1,321.98'$   
 $L = 2,598.50'$   
 $E = 150.52'$   
 $e = \underline{\hspace{1cm}}$   
 T.R. =  $\underline{\hspace{1cm}}$   
 S.E. RUN =  $\underline{\hspace{1cm}}$   
 P.C. STA. = 127+94.58  
 P.T. STA. = 153+93.08

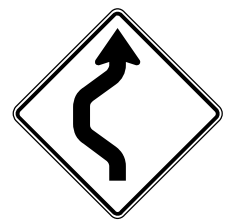

- ARROW BOARD
- TRAFFIC FLOW ARROW
- FULL DEPTH SHOULDER RECONSTRUCTION (PRE-STAGE I)
- WORK AREA
- SIGN
- DIRECTION INDICATOR BARRICADE WITH STEADY BURN MONODIRECTIONAL LIGHT
- TYPE II BARRICADE, DRUM, OR VERTICAL BARRICADE WITH STEADY BURN MONODIRECTIONAL LIGHT
- TEMPORARY IMPACT ATTENUATOR
- TEMPORARY CONCRETE BARRIER

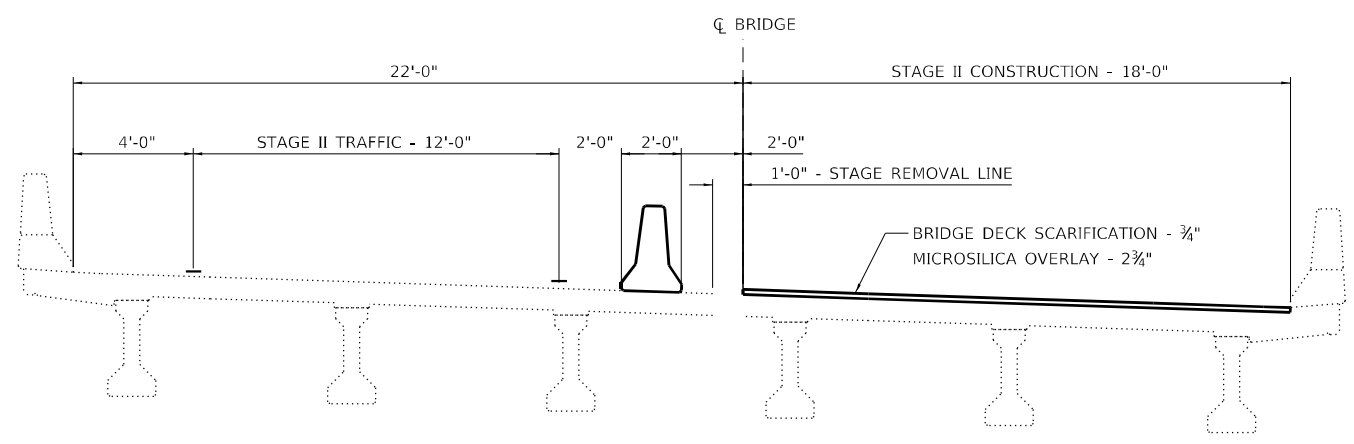

**STAGE II - SN 086-0040**  
 (LOOKING EAST)

MODEL: Default  
 FILE: Mainfile.pxl  
 SUBJECT: new\_bentley.com  
 PLOT DATE: 12/14/2022  
 PROJECT: I:\DOT\Documents\DOT Office\District 6\Projects\0672136\CADD\data\_S5\0672136\Sheet-StageII.dgn

USER NAME = Frank.Caraballo	DESIGNED -	REVISED -
PLOT SCALE = 100,0000' / in.	DRAWN -	REVISED -
PLOT DATE = 12/14/2022	CHECKED -	REVISED -
	DATE -	REVISED -

**STATE OF ILLINOIS  
 DEPARTMENT OF TRANSPORTATION**







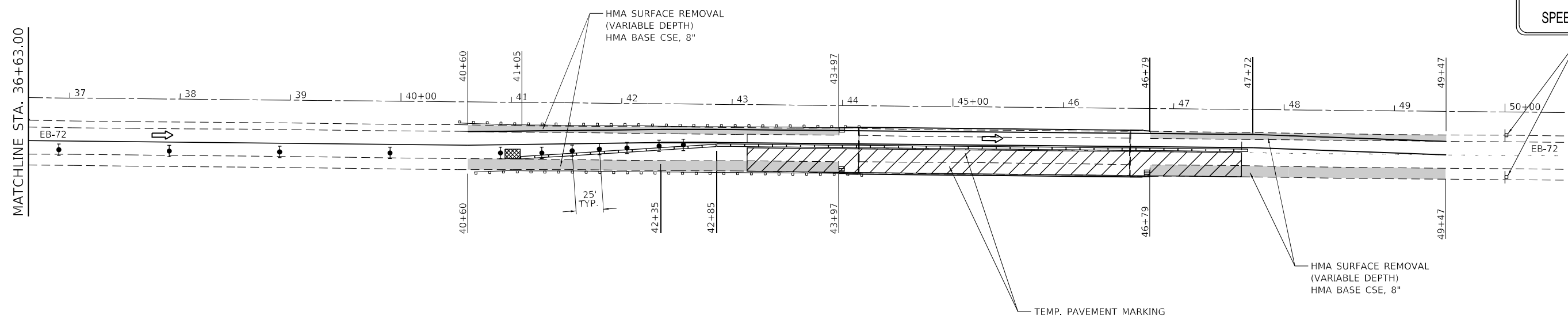

<b>STAGE II - EB I-72 SN 086-0040</b>			
SCALE:	SHEET 11	OF 12 SHEETS	STA. TO STA.

F.A.I. RTE.	SECTION	COUNTY	TOTAL SHEETS	SHEET NO.
72	(86-8)BDR1,BR1,BRR1,BP	SCOTT	45	25
CONTRACT NO. 72136				
ILLINOIS FED. AID PROJECT				



END  
WORK ZONE  
SPEED LIMIT



-  ARROW BOARD
-  TRAFFIC FLOW ARROW
-  FULL DEPTH SHOULDER RECONSTRUCTION (PRE-STAGE I)
-  WORK AREA
-  SIGN
-  DIRECTION INDICATOR BARRICADE WITH STEADY BURN MONODIRECTIONAL LIGHT
-  TYPE II BARRICADE, DRUM, OR VERTICAL BARRICADE WITH STEADY BURN MONODIRECTIONAL LIGHT
-  TEMPORARY IMPACT ATTENUATOR
-  TEMPORARY CONCRETE BARRIER

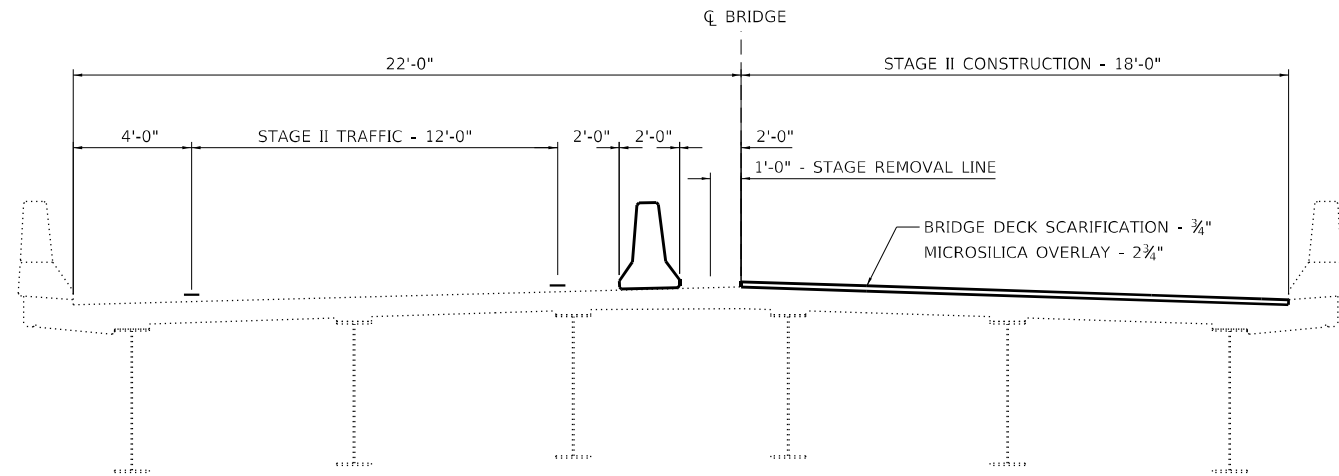

**STAGE II - SN 086-0042**  
(LOOKING EAST)

MODEL: Default  
 FILE: Mainfile.pia  
 PROJECT: \\dot\Documents\DOT Office\District 6\Projects\0672136\CADD\data\_S5\0672136\Sheet\0672136-ehs-Stage10.dgn

USER NAME = Frank.Caraballo	DESIGNED -	REVISED -
PLOT SCALE = 100,0000' / in.	DRAWN -	REVISED -
PLOT DATE = 12/14/2022	CHECKED -	REVISED -
	DATE -	REVISED -

**STATE OF ILLINOIS  
DEPARTMENT OF TRANSPORTATION**

**STAGE II - EB I-72  
SN 086-0042**

SCALE: SHEET 12 OF 12 SHEETS STA. TO STA.

F.A.I. RTE.	SECTION	COUNTY	TOTAL SHEETS	SHEET NO.
72	(86-8)BDR1,BR1,BRR1,BP	SCOTT	45	26
CONTRACT NO. 72136				
ILLINOIS FED. AID PROJECT				

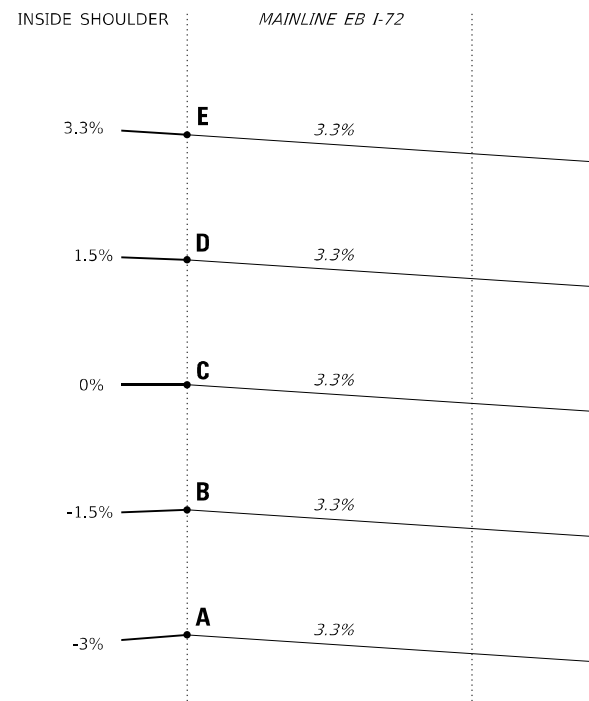

**SHOULDER SUPERELEVATION TRANSITION**  
**SN 086-0040**

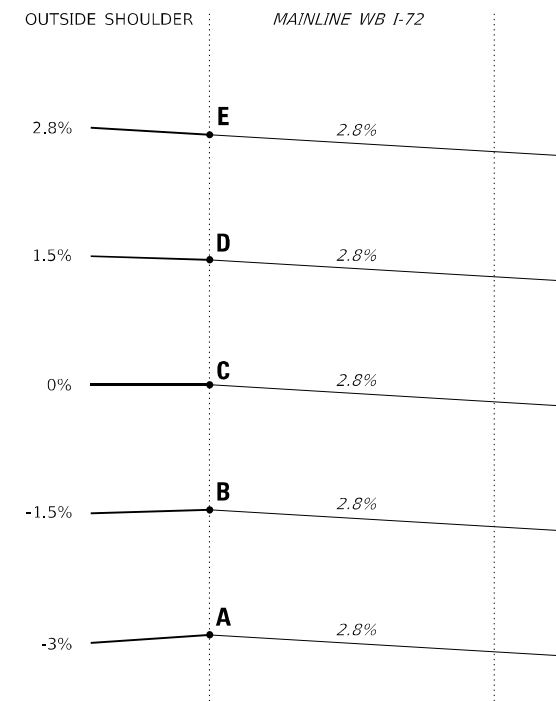

**SHOULDER SUPERELEVATION TRANSITION**  
**SN 086-0041**

SHOULDER SUPERELEVATION CORRECTION						
LOCATION	e	A	B	C	D	E
SN 086-0040 (WEST)	3.3%	STA 143+54.00	STA 143+91.00	STA 144+28.00	STA 144+65.00	STA 145+09.00
SN 086-0040 (EAST)	3.3%	STA 148+02.00	STA 147+72.00	STA 147+42.00	STA 147+12.00	STA 146+77.00
SN 086-0041 (WEST)	2.8%	STA 642+78.00	STA 643+18.00	STA 643+58.00	STA 643+98.00	STA 644+33.00
SN 086-0041 (EAST)	2.8%	STA 647+55.00	STA 647+15.00	STA 646+75.00	STA 646+35.00	STA 646+00.00

NOTE:  
1. SUPERELEVATION CORRECTION TO BE DONE DURING PRE-STAGING SHOULDER REPLACEMENT.

MODEL: Default  
 FILE NAME: p:\ultra-dwg-bead-fay.com\PIV\DOT\Documents\DOT Office\Dir\dir: E:\Project\0672136\CAD\Drawings\_S5\0672136\shft-cover.dgn

USER NAME = Frank.Caraballo	DESIGNED -	REVISED -
PLOT SCALE = 100,0000' / in.	DRAWN -	REVISIED -
PLOT DATE = 12/14/2022	CHECKED -	REVISIED -
	DATE -	REVISIED -

**STATE OF ILLINOIS**  
**DEPARTMENT OF TRANSPORTATION**

**SHOULDER SUPERELEVATION TRANSITION DETAIL**  
**SN 086-0040 & SN 086-0041**

SCALE: SHEET OF SHEETS STA. TO STA.

F.A.I. RTE.	SECTION	COUNTY	TOTAL SHEETS	SHEET NO.
72	(86-8)BDR1,BJR1,BRR1,BP	SCOTT	45	27
ILLINOIS FED. AID PROJECT			CONTRACT NO. 72136	

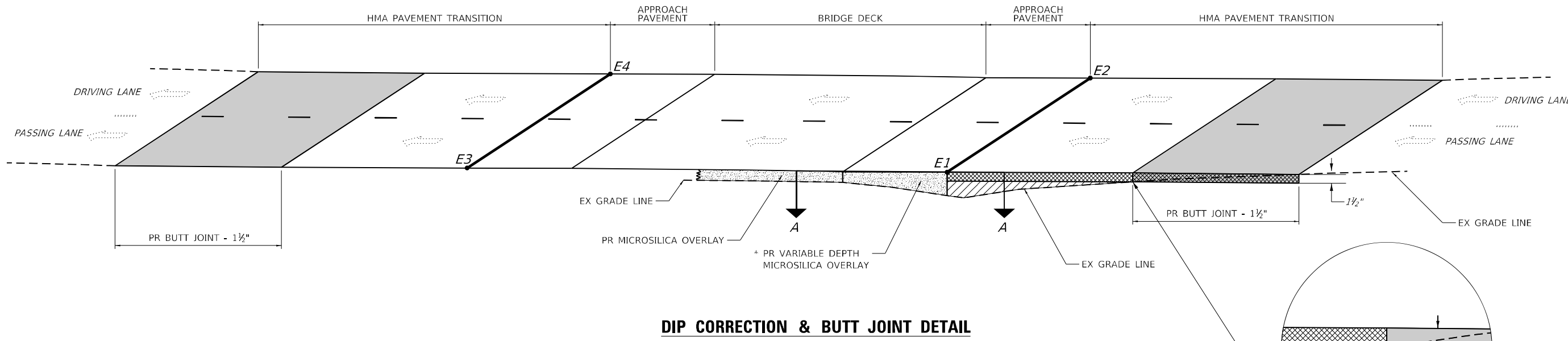

**DIP CORRECTION & BUTT JOINT DETAIL**

\* TO BE PAID FOR ACCORDING TO SPECIAL PROVISION FOR BRIDGE DECK MICROSILICA CONCRETE OVERLAY.

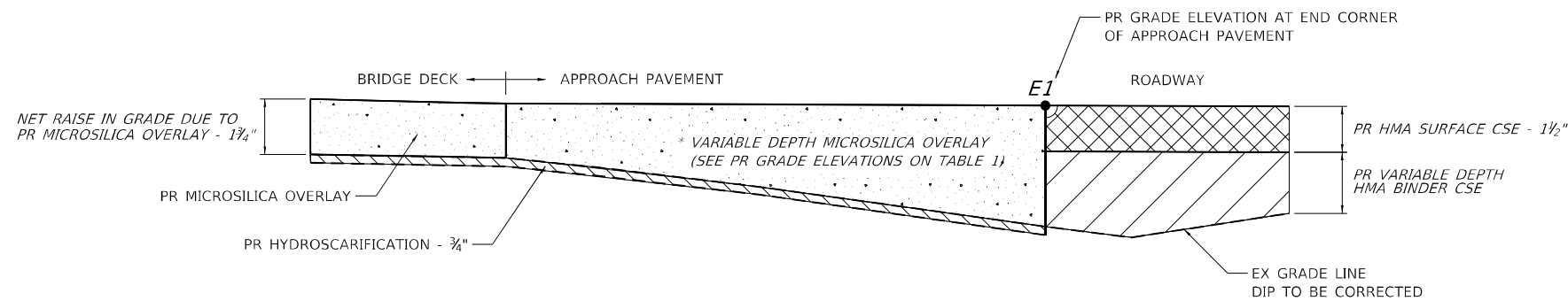

**SECTION A-A**

SN 086-0040 (EB I72)					
POINT NO.	STATION	OFFSET (FT)		PR ELEVATION (FT)	PR OVERLAY THICKNESS
E1	145+11.00	1.15	RT	445.85	2.9"
E2	145+10.00	24.9	RT	446.63	2.6"
E3	146+77.00	0.93	RT	445.86	3.2"
E4	146+76.00	24.83	RT	446.64	2.5"
SN 086-0041 (WB I72)					
POINT NO.	STATION	OFFSET (FT)		PR ELEVATION (FT)	PR OVERLAY THICKNESS
E1	645+99.00	0.21	LT	446.86	4.3"
E2	645+98.00	24	LT	447.53	4.6"
E3	644+34.00	0.16	LT	446.84	4.1"
E4	644+34.00	24	LT	447.5	4.3"

**TABLE 1**

MODEL: Default  
 FILE: Mainfile.pia  
 SUBJECT: new benchtop.com\FW\DOT\Documents\DOT\_offset\District\_6\Project\0672136\CADD\data\_5510\CADD\sheet\0672136-sht-c-over.dgn

USER NAME = Frank.Caraballo	DESIGNED -	REVISED -
PLOT SCALE = 100,0000' / in.	DRAWN -	REVISED -
PLOT DATE = 12/14/2022	CHECKED -	REVISED -
	DATE -	REVISED -

**STATE OF ILLINOIS  
DEPARTMENT OF TRANSPORTATION**

**DIP CORRECTION & BUTT JOINT DETAIL  
SN 086-0040 & SN 086-0041**

SCALE: SHEET OF SHEETS STA. TO STA.

F.A.I. RTE.	SECTION	COUNTY	TOTAL SHEETS	SHEET NO.
72	(86-8)BDR1,BJR1,BRR1,BP	SCOTT	45	28
CONTRACT NO. 72136				
ILLINOIS FED. AID PROJECT				

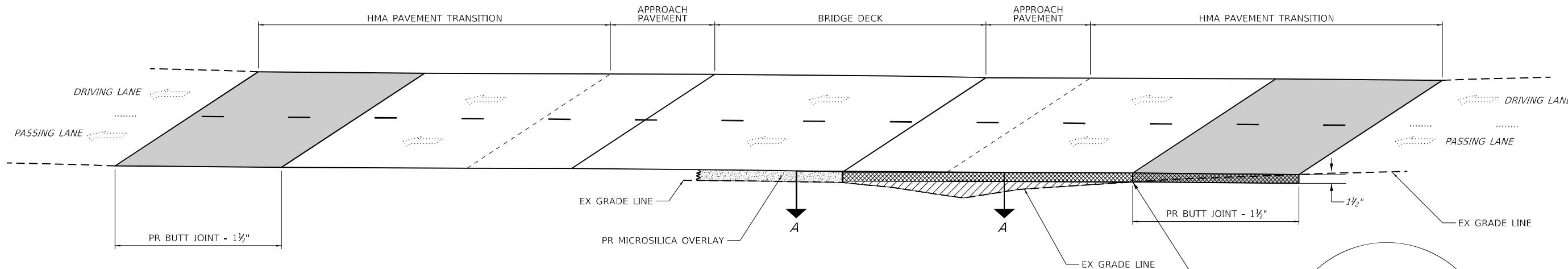

**DIP CORRECTION & BUTT JOINT DETAIL**

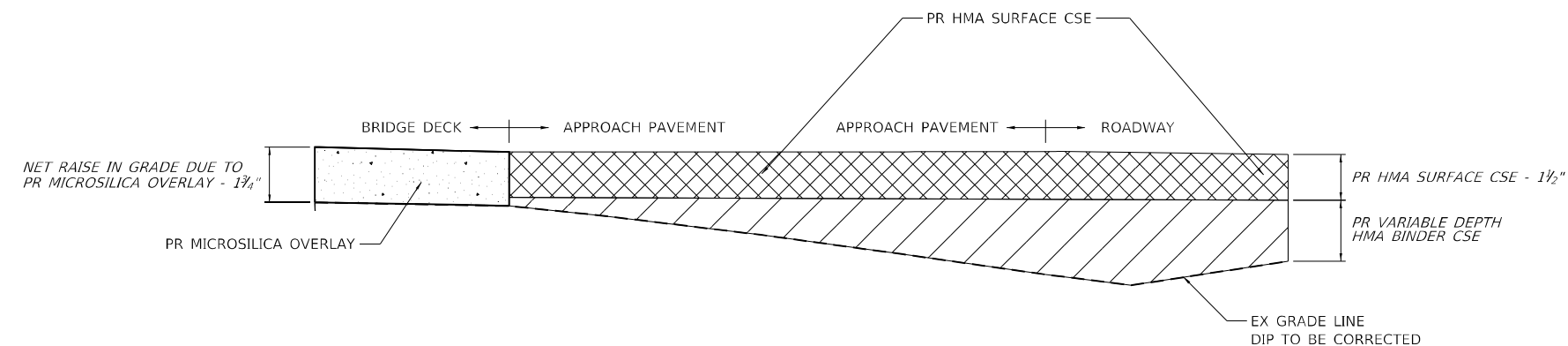
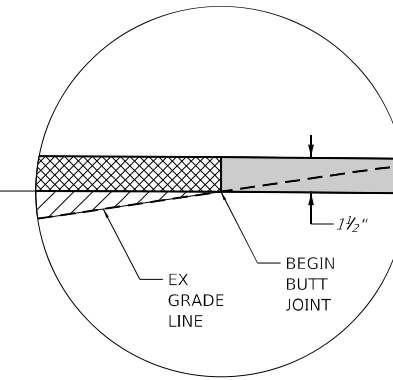

**SECTION A-A**

MODEL: Default  
 FILE NAME: p:\ultra-dwg-beadray.com\p\i\DOT\Documents\DOT\_offices\District\_6\Project\0672136\CADD\data\_55\0672136\CADD\data\_55\ultra-dwg-beadray.com\p\i\DOT\Documents\DOT\_offices\District\_6\Project\0672136\CADD\data\_55\ultra-cure.dgn

USER NAME = Frank.Caraballo	DESIGNED -	REVISED -
PLOT SCALE = 100,0000' / in.	DRAWN -	REVISED -
PLOT DATE = 12/14/2022	CHECKED -	REVISED -
	DATE -	REVISED -

**STATE OF ILLINOIS**  
**DEPARTMENT OF TRANSPORTATION**

<b>DIP CORRECTION &amp; BUTT JOINT DETAIL</b> <b>SN 086-0042 &amp; SN 086-0043</b>			
SCALE:	SHEET	OF	SHEETS
	STA.	TO	STA.

F.A.I. RTE.	SECTION	COUNTY	TOTAL SHEETS	SHEET NO.
72	(86-8)BDR1,BJR1,BRR1,BP	SCOTT	45	29
CONTRACT NO. 72136				
ILLINOIS FED. AID PROJECT				

DETAIL: INLET BOXES TO BE ADJUSTED

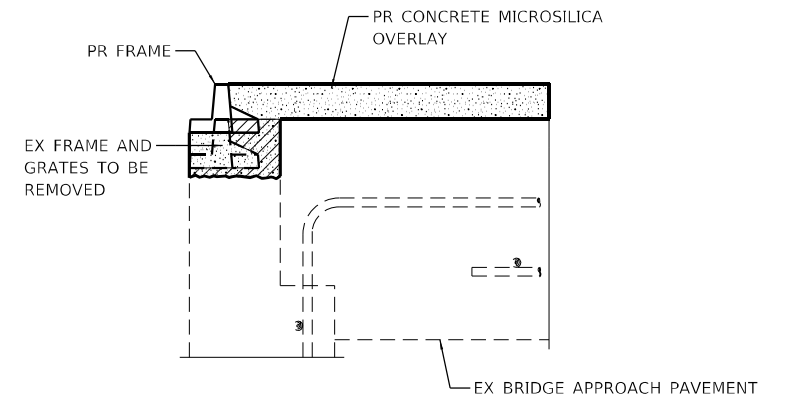
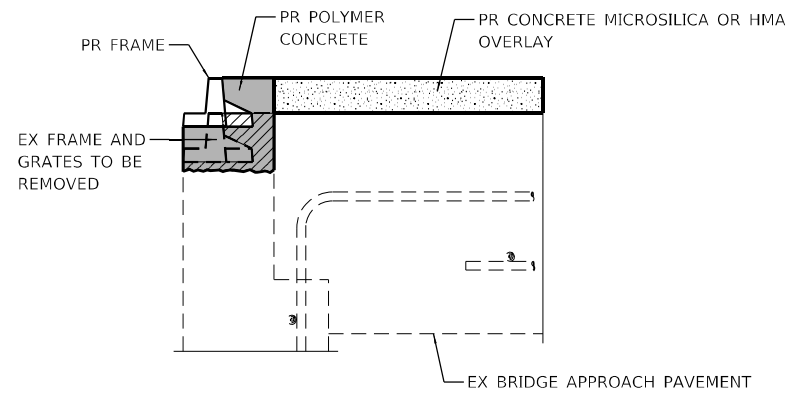
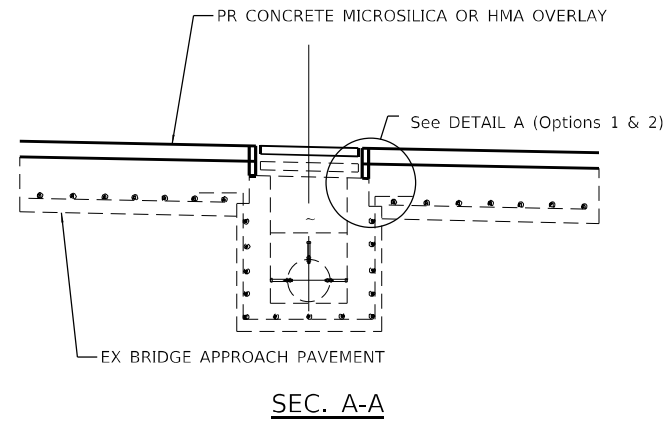

DETAIL A (Option 1)

DETAIL B (Option 2)

- POLYMER CONCRETE
- CONCRETE REMOVAL
- CONCRETE MICROSilICA OR HMA OVERLAY

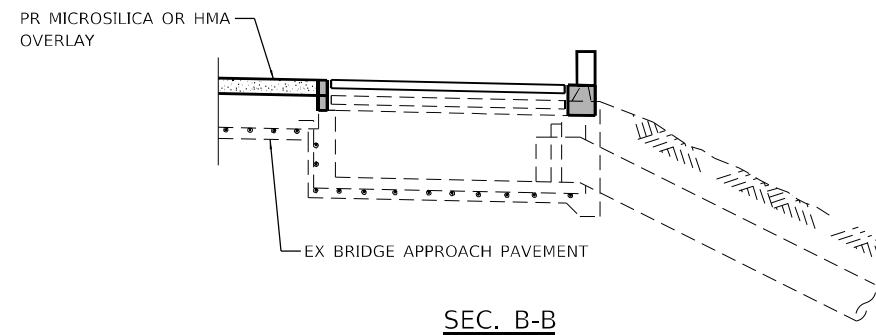
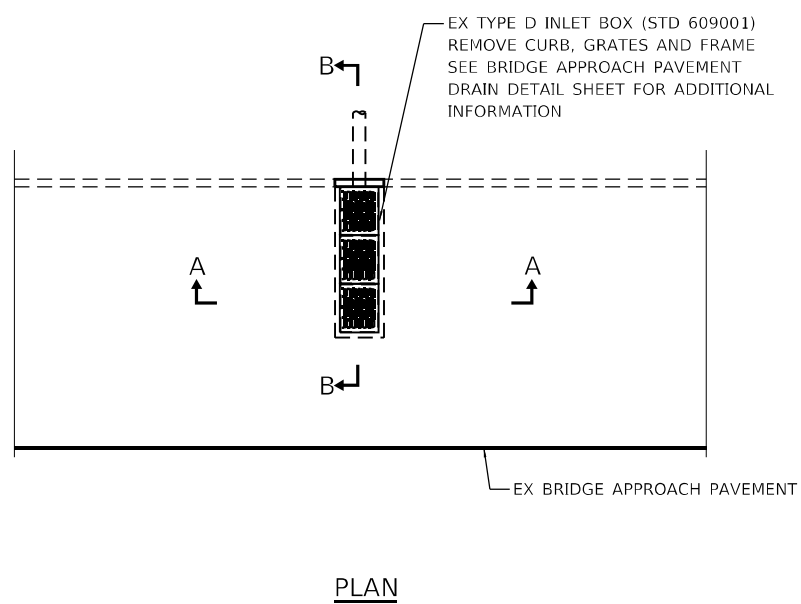

SEC. B-B

- CONCRETE MICROSilICA OR POLYMER CONCRETE SEE OPTIONS 1 & 2 ABOVE

MODEL: Default  
 FILE: M:\MFC - public\paw\_bentley.com\PIV\DOT\Documents\DOT - Offices\District: 6\Project\0672136\CADD\data\_5510\CADD\sheet\0672136-sht-detailed.dgn

USER NAME = Frank.Caraballo	DESIGNED -	REVISED -
	DRAWN -	REVISED -
PLOT SCALE = 100,0000' / in.	CHECKED -	REVISED -
PLOT DATE = 12/15/2022	DATE -	REVISED -

**STATE OF ILLINOIS  
DEPARTMENT OF TRANSPORTATION**

**INLET TO BE ADJUSTED WITH NEW FRAME AND GRATE  
DETAIL**

SCALE: SHEET OF SHEETS STA. TO STA.

F.A.I. RTE.	SECTION	COUNTY	TOTAL SHEETS	SHEET NO.
72	(86-8)BDR1,BJR1,BRR1,BP	SCOTT	45	30
CONTRACT NO. 72136				
ILLINOIS		FED. AID PROJECT		

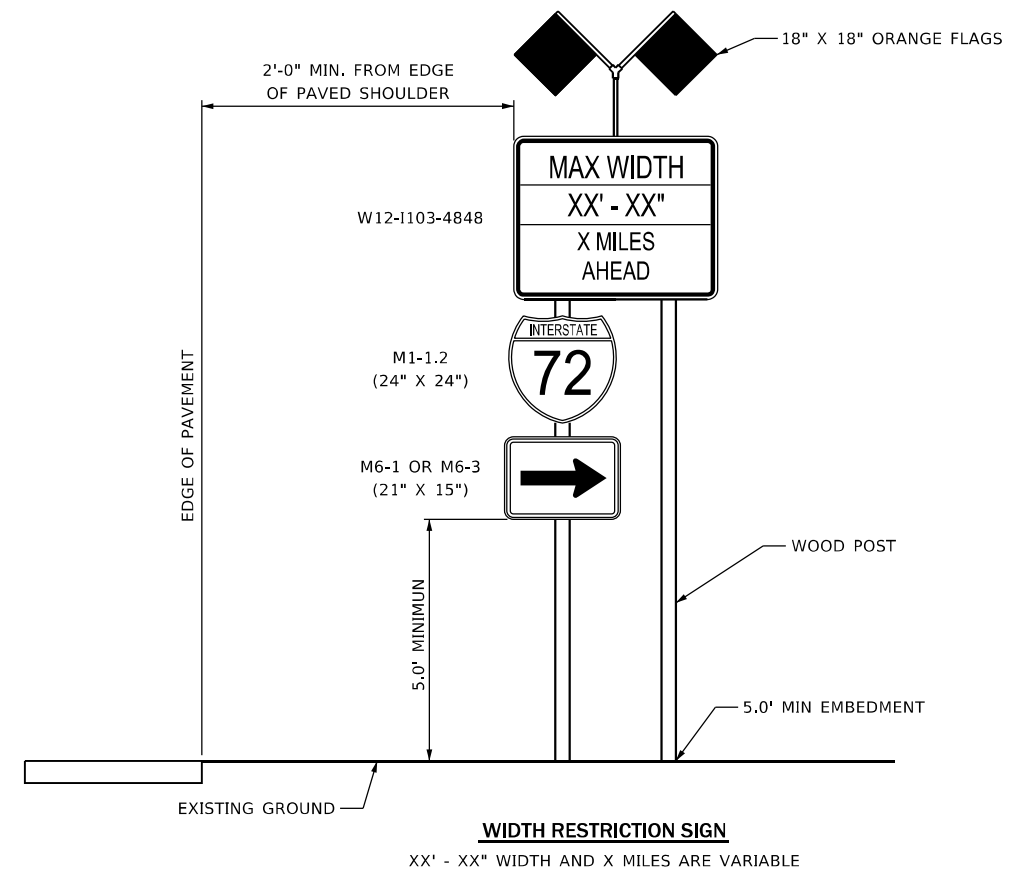
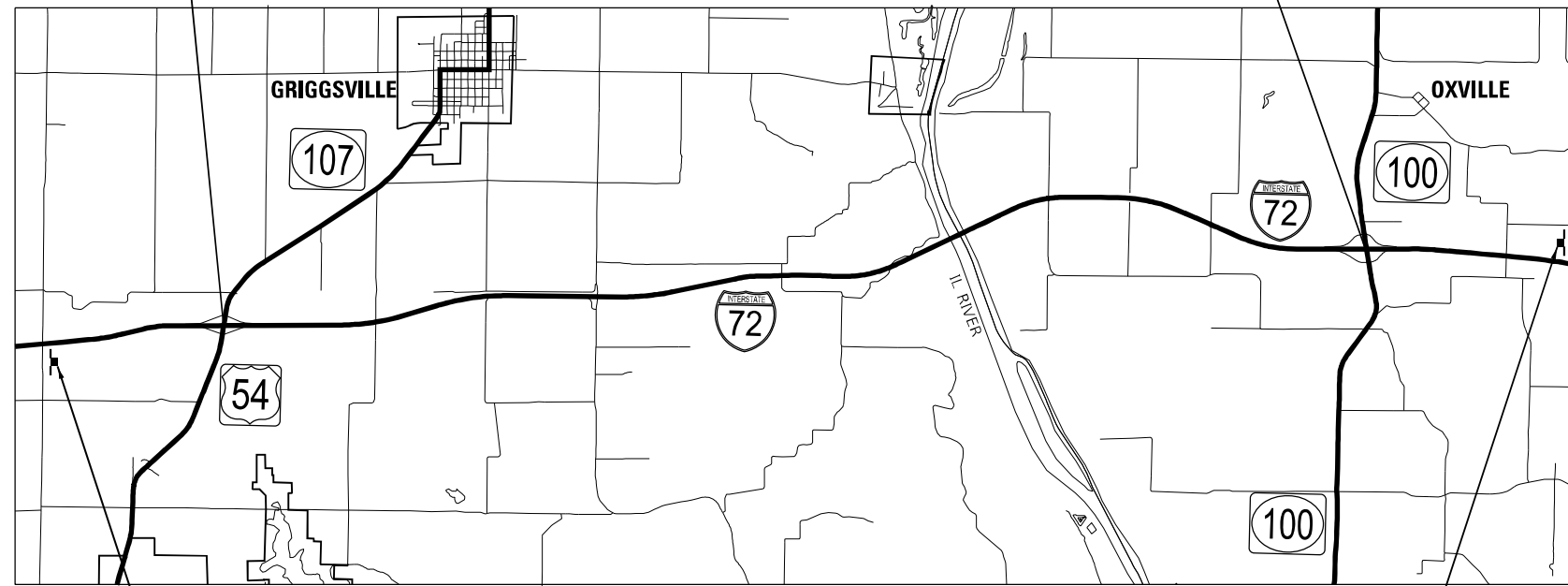
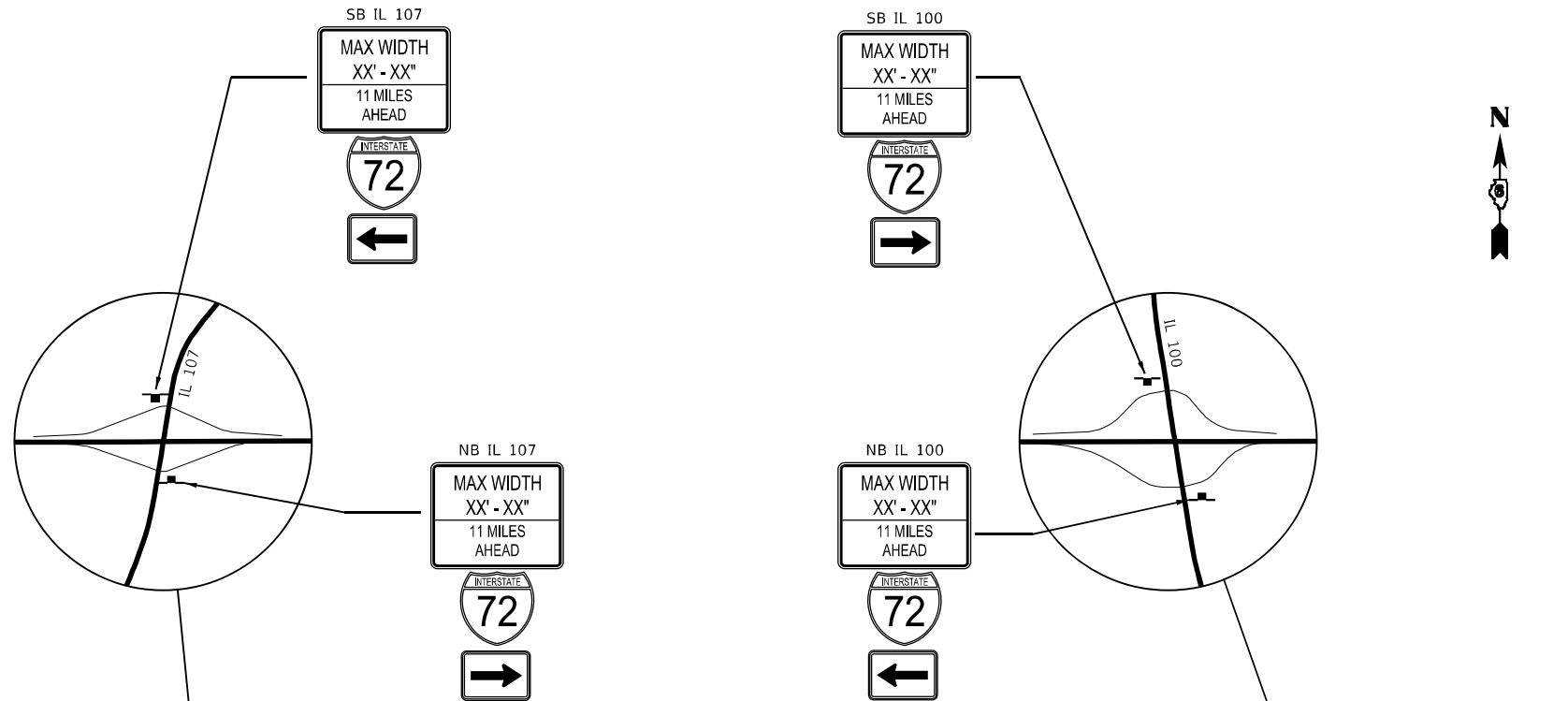

MODEL: Default  
 FILE: Mainfile.pxd  
 SUBJECT: new benchmark.com\FWIDOT\Documents\DOT Office\Director: E:\Project\0672136\CADD\data\_S5\0672136\CADD\sheet\0672136-sheet-cover.dgn

USER NAME = Frank,Caraballo	DESIGNED -	REVISED -
DRAWN -	REVISED -	
PLOT SCALE = 100,0000' / in.	CHECKED -	REVISED -
PLOT DATE = 12/14/2022	DATE -	REVISED -

**STATE OF ILLINOIS  
DEPARTMENT OF TRANSPORTATION**

**WIDTH RESTRICTION SIGNING  
DETAIL**

SCALE: SHEET OF SHEETS STA. TO STA.

F.A.I. RTE.	SECTION	COUNTY	TOTAL SHEETS	SHEET NO.
72	(86-8)BDR1,BJR1,BRR1,BP	SCOTT	45	31
CONTRACT NO. 72136				
ILLINOIS FED. AID PROJECT				

**GENERAL NOTES**

Plan dimensions and details relative to existing plans are subject to nominal construction variations. The Contractor shall field verify existing dimensions and details affecting new construction and make necessary approved adjustments prior to construction or ordering of materials. Such variations shall not be cause for additional compensation for a change in scope of the work, however, the Contractor will be paid for the quantity actually furnished at the unit price bid for the work. Traffic will be maintained using stage construction. Clean the washout area under drains and install Class A4 Riprap in accordance with the Standard Specifications. Engineer should verify the width of washout area. Quantity shown is an estimate. Engineer shall determine the quantity of Riprap at the project location. The overlay thickness in excess of 2 3/4" shall be paid for as outlined in the special provisions for Bridge Deck Concrete Overlay, 2 3/4"

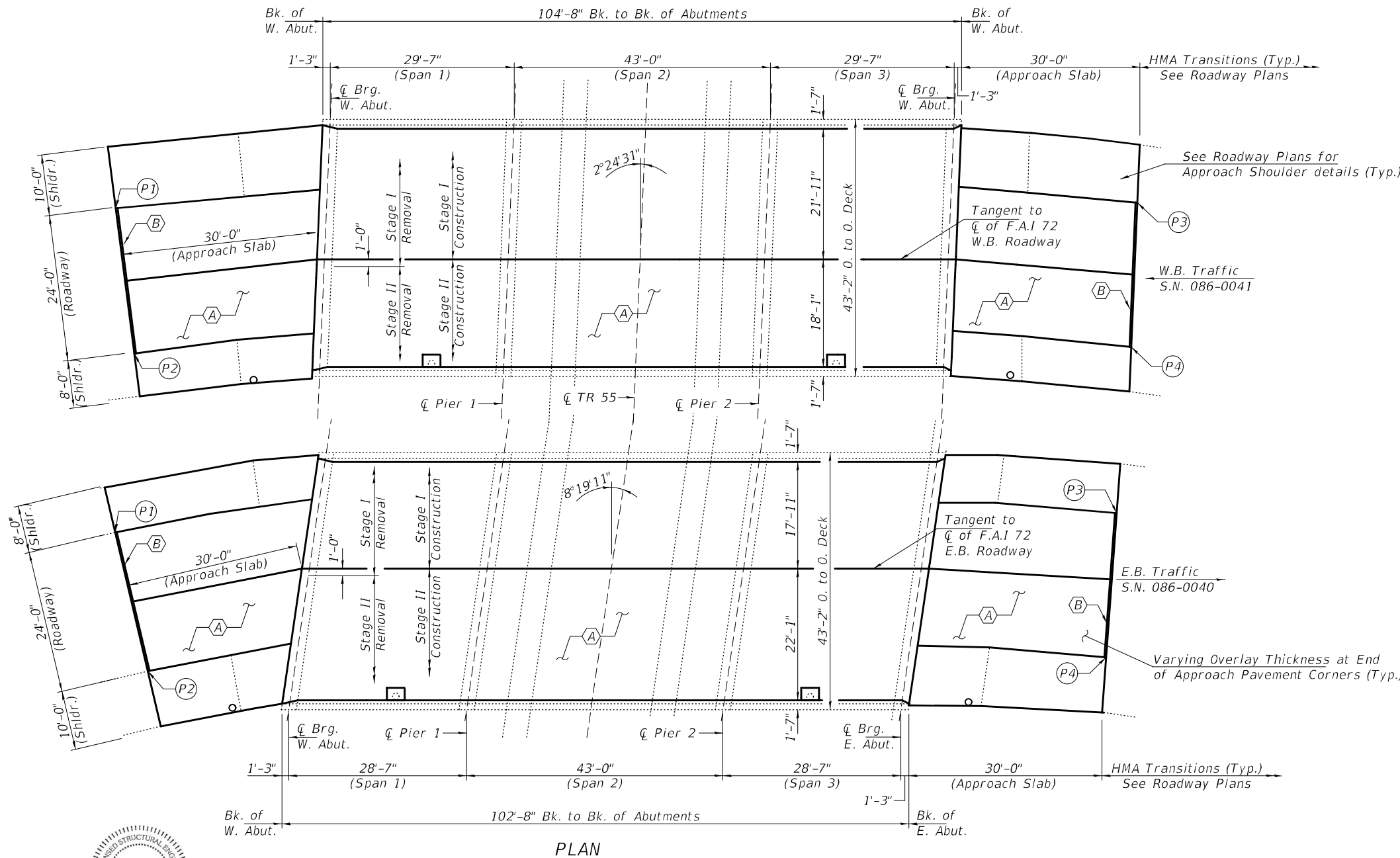
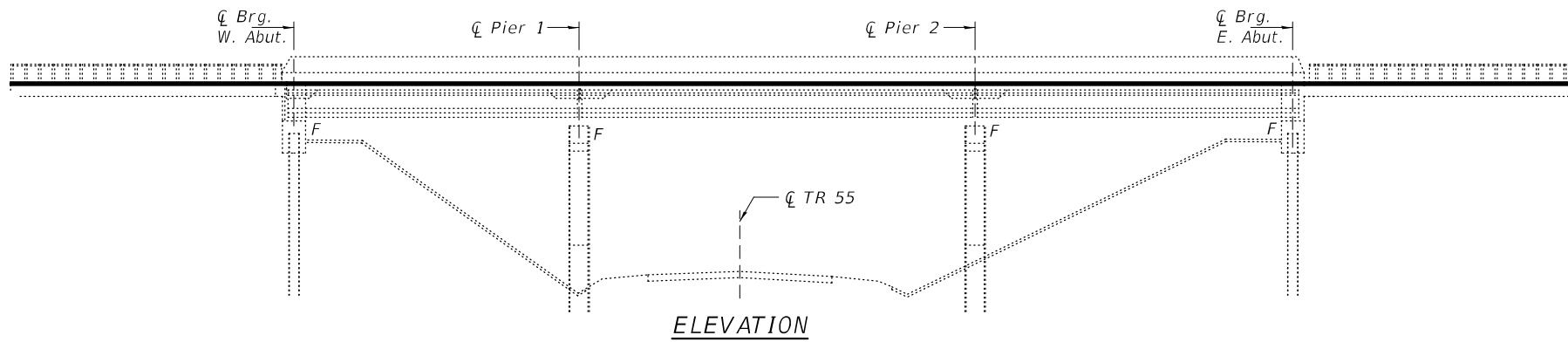

**OVERLAY THICKNESS TABLE**

(Prior to 1/4" Grinding)

LOCATION POINTS	0040 (EB)	0041 (WB)
N.W. Corner of W. Approach - P1	3 1/2"	5 3/8"
S.W. Corner of W. Approach - P2	4 1/4"	5 1/8"
N.E. Corner of E. Approach - P3	3 5/8"	5 1/2"
S.E. Corner of E. Approach - P4	3 7/8"	5 3/8"

**TOTAL BILL OF MATERIAL**

ITEM	UNIT	QUANTITY
Bridge Deck Scarification 3/4"	Sq. Yd.	1242
Diamond Grinding (Bridge Section)	Sq. Yd.	1150
* Protective Coat	Sq. Yd.	1242
* Bridge Deck Microsilica Concrete Overlay, 2 3/4"	Sq. Yd.	1242
** Deck Slab Repair (Full Depth, Type II)	Sq. Yd.	5
Bridge Deck Grooving (Longitudinal)	Sq. Yd.	873
Polymer Concrete	Cu. Ft.	41
Stone Riprap, Class A4	Sq. Yd.	1

\* Apply to new concrete only.  
 \*\* Quantity is estimated. Location and size of patches to be determined in the field by the Engineer.

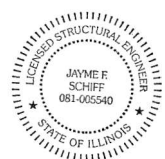

EXPIRES 11-30-2024

- (A) - 3/4" Bridge Deck Scarification, 2 3/4" min. Microsilica Concrete Overlay & 1/4" Diamond Grinding
- (B) - Polymer Concrete Nosing (See Repair B).

DESIGNED - Adrian T. Holloway  
 CHECKED - Chi-Cheung Chai  
 DRAWN - Venkat Ramana Reddy  
 CHECKED - ATH CCC

PASSED

Jayme F. Schiff  
 ENGINEER OF BRIDGES AND STRUCTURES

DATE - February 2, 2023

REVISED -  
 REVISED -

STATE OF ILLINOIS  
 DEPARTMENT OF TRANSPORTATION

GENERAL PLAN AND ELEVATION  
 F.A.P. 408 (F.A.I. 72) OVER TR 55  
 SN 086-0040 (EB) & 086-0041 (WB)

SHEET NO. 1 OF 2 SHEETS

F.A.I. RTE.	SECTION	COUNTY	TOTAL SHEETS	SHEET NO.
72	(86-8) BDR1,BUR1,BRR1,BP	SCOTT	45	32

CONTRACT NO. 72136

ILLINOIS FED. AID PROJECT



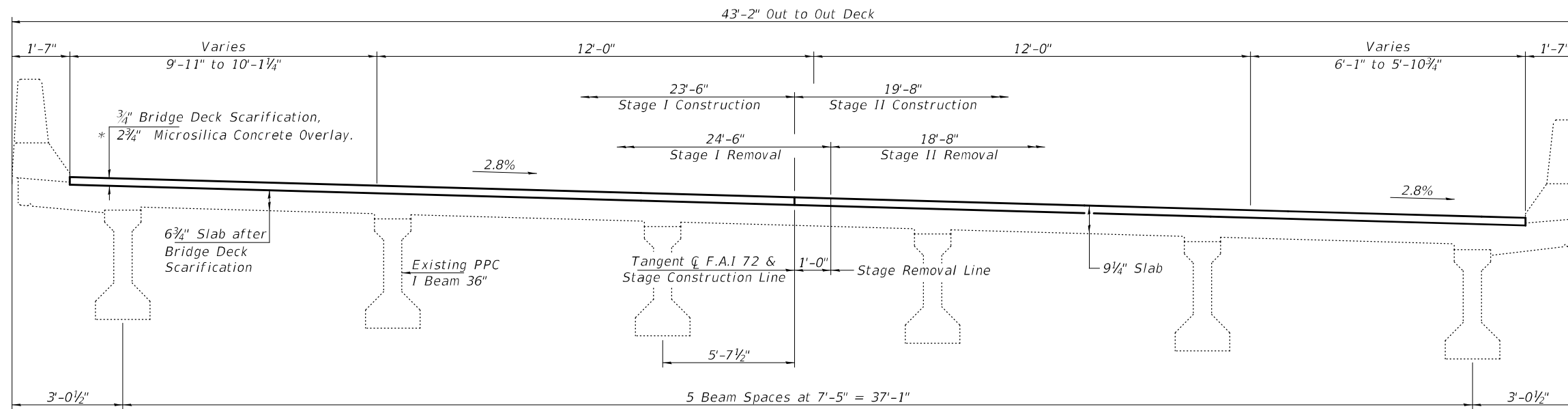

**CROSS SECTION 086-0041 (WB)**

(Looking East)

\* Prior to 1/4" Diamond Grinding

43'-2" Out to Out Deck

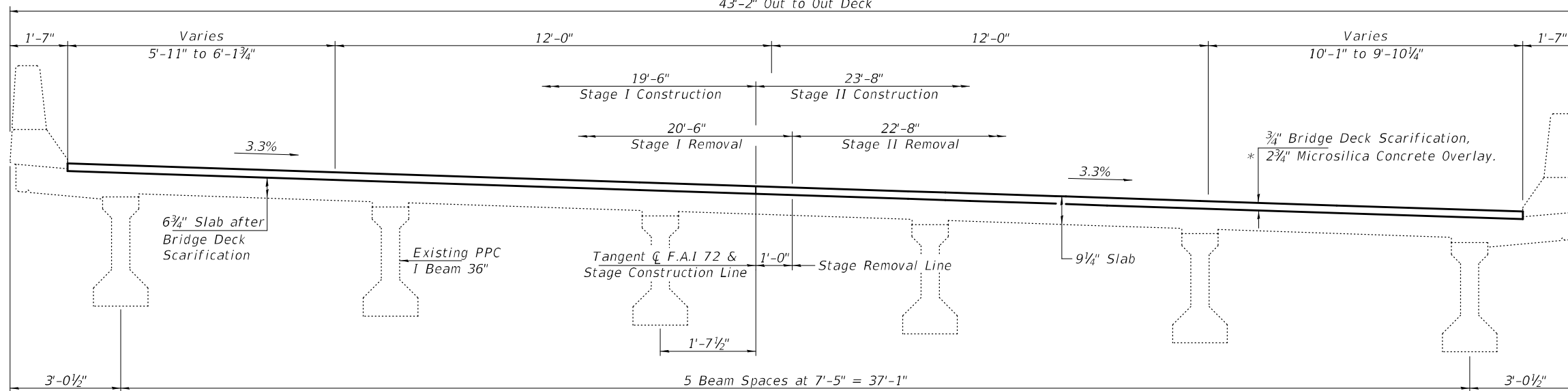

**CROSS SECTION 086-0040 (EB)**

(Looking East)

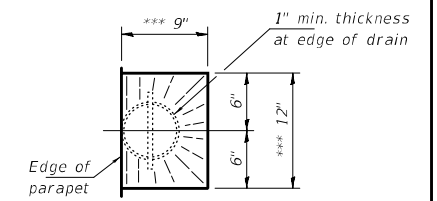

**DRAIN DETAIL**

\*\*\* slope to drain

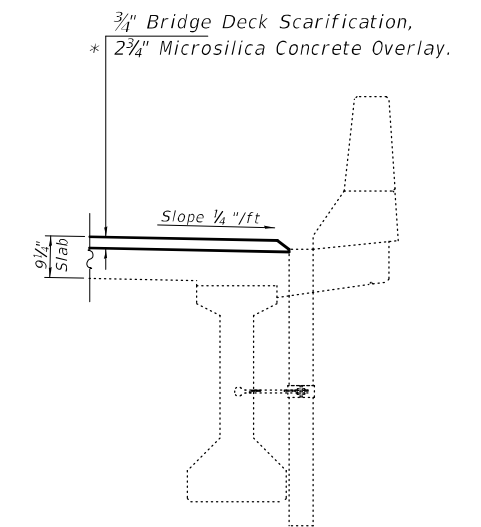

**SECTION THRU PARAPET**

(at drain)

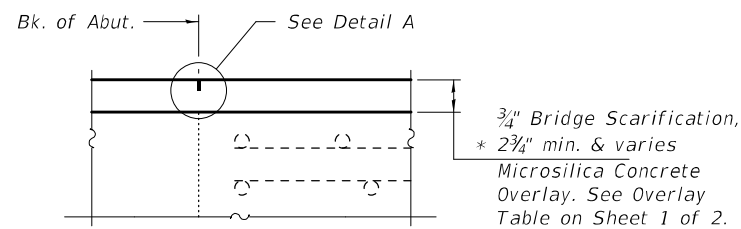

**SECTION AT ABUTMENT**

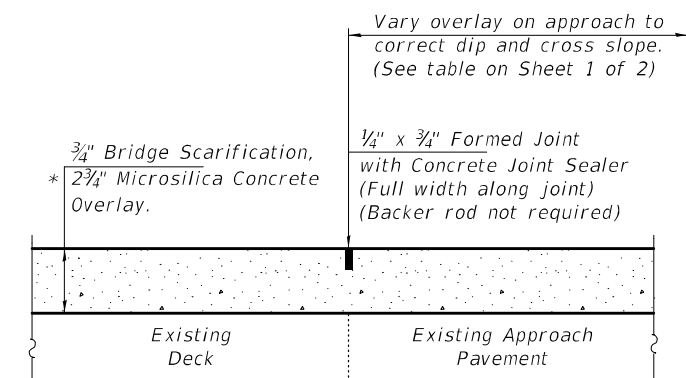

**DETAIL A**

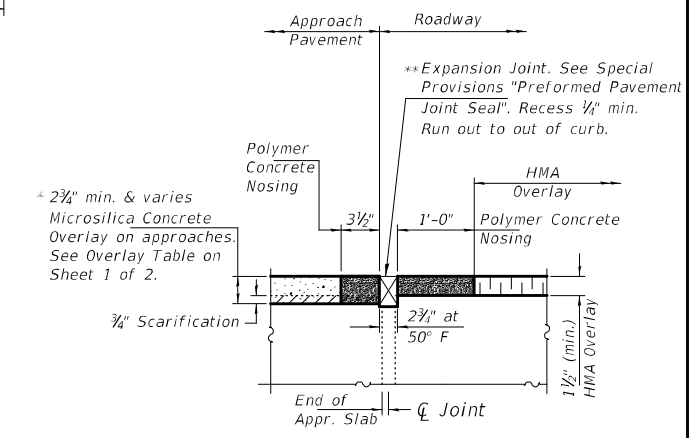

**REPAIR B**

\* Prior to 1/4" Diamond Grinding  
\*\* Cost included with Polymer Concrete

DESIGNED - ATH  
CHECKED - CCC  
DRAWN - Venkat Ramana Reddy  
CHECKED - ATH CCC

PASSED

*Jaime F. J. [Signature]*  
ENGINEER OF BRIDGES AND STRUCTURES

DATE - February 2, 2023

REVISED -  
REVISED -

STATE OF ILLINOIS  
DEPARTMENT OF TRANSPORTATION

CROSS SECTIONS & STAGING DETAILS  
SN 086-0040 (EB) & 086-0041 (WB)

SHEET NO. 2 OF 2 SHEETS

F.A.I. RTE.	SECTION	COUNTY	TOTAL SHEETS	SHEET NO.
72	(86-8) BDR1,BJR1,BRR1,BP	SCOTT	45	33
CONTRACT NO. 72136				

ILLINOIS FED. AID PROJECT

**GENERAL NOTES**

All structural steel shall conform to AASHTO Classification M-270 Gr. 36, unless otherwise noted.  
 Plan dimensions and details relative to existing plans are subject to nominal construction variations. The Contractor shall field verify existing dimensions and details affecting new construction and make necessary approved adjustments prior to construction or ordering of materials. Such variations shall not be cause for additional compensation for a change in scope of the work, however, the Contractor will be paid for the quantity actually furnished at the unit price bid for the work.  
 Prior to pouring the new concrete deck, all heavy or loose rust, loose mill scale, and other loose or potentially detrimental foreign material shall be removed from the surfaces in contact with concrete. Tightly adhered paint may remain unless otherwise noted. Removal shall be accomplished by methods that will not damage the steel and the cost will be included in the pay item covering removal of the existing concrete.  
 Reinforcement bars designated (E) shall be epoxy coated.  
 Existing reinforcement bars extending into the removal area shall be cleaned, straightened and incorporated into the new construction. Any reinforcement bars that are damaged during concrete removal shall be replaced with an approved bar splicer or anchorage system. Cost included with Concrete Removal.  
 Joint openings shall be adjusted according to Article 520.04 of the Standard Specifications when the deck is poured at an ambient temperature other than 50° F. Traffic will be maintained using stage construction.  
 Cleaning and painting of the existing structural steel shall be specified in the special provision for "Cleaning and Painting Existing Steel Structures". All beams within 10 ft. of the beam ends shall be cleaned per Near White Blast Cleaning (SSPC-SP10).  
 The designated areas cleaned per Near White Blast Cleaning (SSPC-SP10) shall be painted according to the requirements of Paint System 1 (OZ/E/U). The color of the final finish coat for all steel surfaces shall be Gray, Munsell No. 5B 7/1. SSPC-QP1 Painting Contractor Certifications will be required for this contract. A minimum of one (1) air monitor is required for this project.  
 The overlay thickness in excess of 2 3/4" shall be paid for as outlined in the special provisions for Bridge Deck Microsilica Concrete Overlay, 2 3/4".

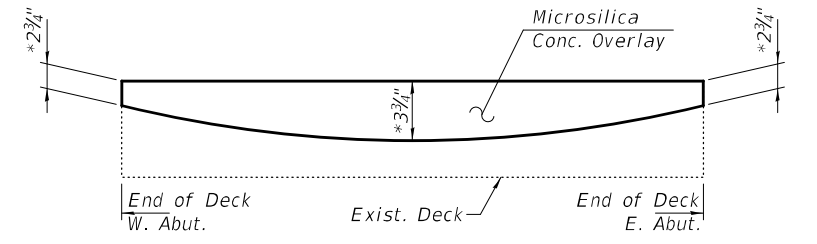
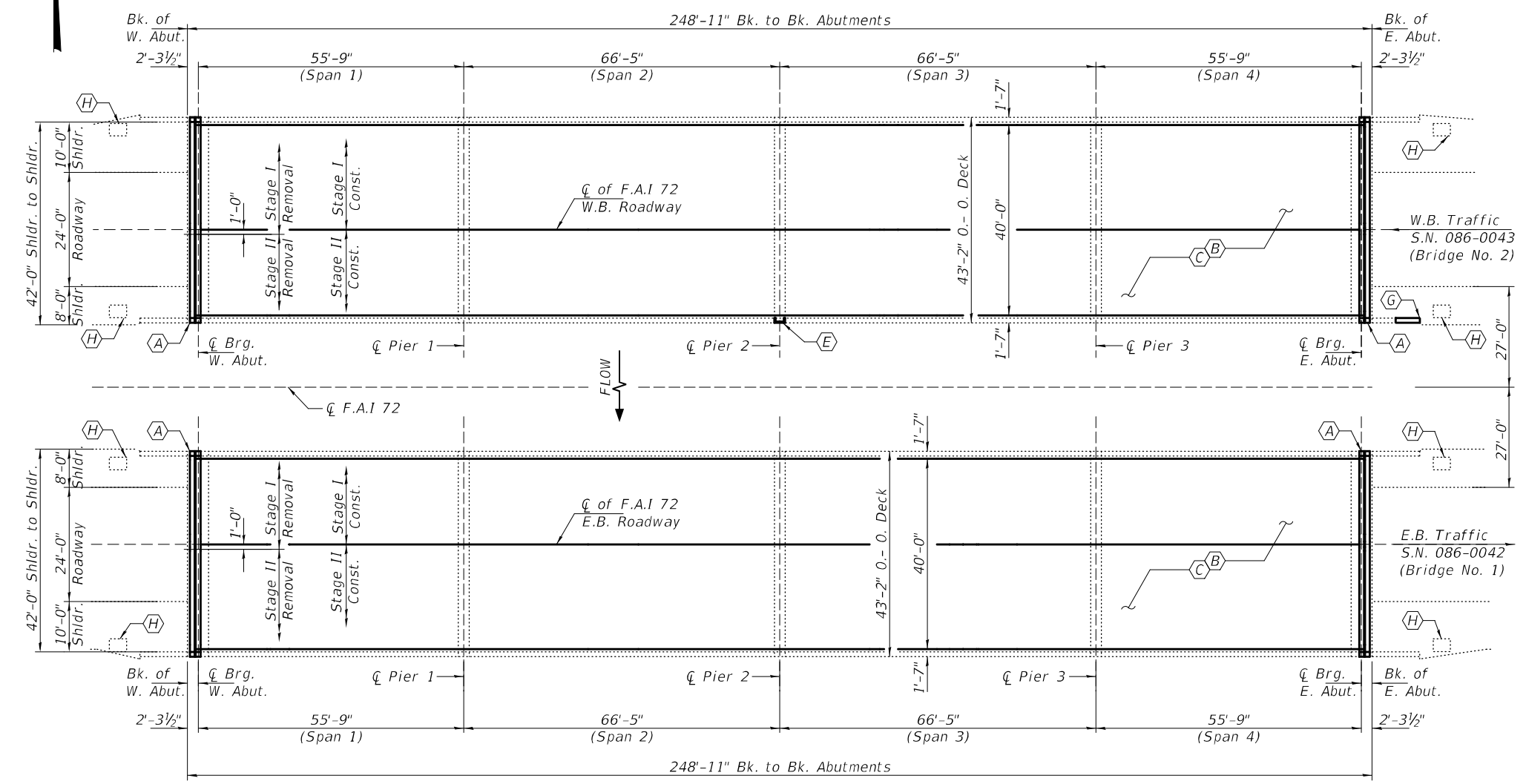
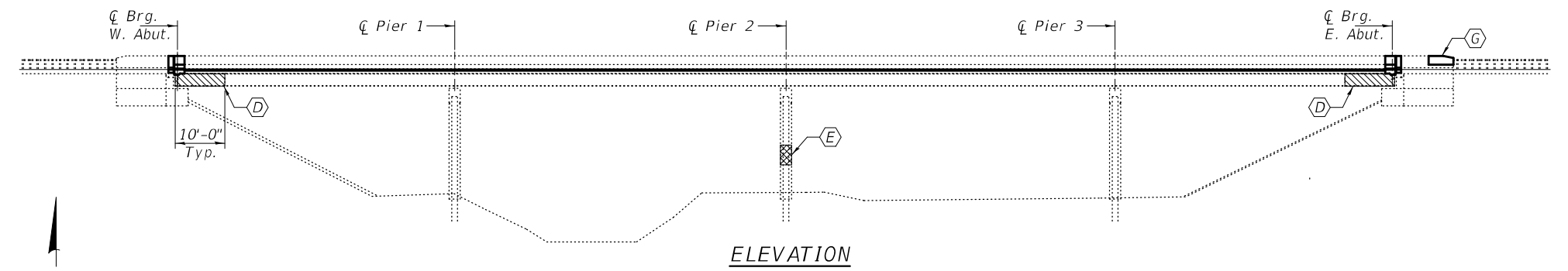

**OVERLAY DETAIL**

\* Prior to 1/4" Diamond Grinding

**TOTAL BILL OF MATERIAL**

ITEM	UNIT	QUANTITY
Bridge Deck Scarification 3/4"	Sq. Yd.	2184
Diamond Grinding (Bridge Section)	Sq. Yd.	1991
* Protective Coat	Sq. Yd.	2222
* Bridge Deck Microsilica Concrete Overlay, 2 3/4"	Sq. Yd.	2184
Reinforcement Bars, Epoxy Coated	Pound	3000
Concrete Removal	Cu. Yd.	21.5
Deck Slab Repair (Full Depth, Type II)	Sq. Yd.	32
** Approach Slab Repair (Partial Depth)	Sq. Yd.	40
Bridge Deck Grooving (Longitudinal)	Sq. Yd.	1328
Concrete Superstructure	Cu. Yd.	25.0
Structural Repair of Concrete (Depth ≤ 5")	Sq. Ft.	283
Cleaning and Painting Steel Bridge No. 1	L. Sum	1
Cleaning and Painting Steel Bridge No. 2	L. Sum	1
Containment and Disposal of Non-Lead Paint Residues No. 1	L. Sum	1
Containment and Disposal of Non-Lead Paint Residues No. 2	L. Sum	1
Inlets to be Adjusted with New Frame and Grate (Special)	Each	8
Preformed Joint Strip Seal	Foot	168
Bar Splicers	Each	48

\* Apply to new concrete only.  
 \*\* Quantity is estimated. Location and size of patches to be determined in the field by the Engineer.

- (A) - Remove existing Neoprene Joints and install New Preformed Joint Strip Seal.
- \*\* (B) - Deck Patching (Full Depth).
- (C) - 3/4" Bridge Deck Scarification, 2 3/4" min. Microsilica Concrete Overlay & 1/4" Diamond Grinding.
- (D) - Blast and paint Beam Ends up to 10ft, End Diaphragms & Abutment Bearings.
- (E) - Substructure Repairs.
- (F) - Approach Slab Repair (Partial Depth).
- (G) - Parapet Repair.
- (H) - Approach Inlet Grate Adjustment.

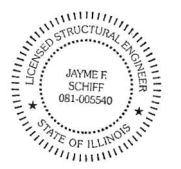

EXPIRES 11-30-2024

DESIGNED - Adrian T. Halloway	DATE - February 2, 2023
CHECKED - Chi-Cheung Chai	REVISOR -
DRAWN - Venkat Ramana Reddy	REVISOR -
CHECKED - ATH CCC	

**STATE OF ILLINOIS  
 DEPARTMENT OF TRANSPORTATION**

**GENERAL PLAN AND ELEVATION  
 FAI 72 (US RTE 36) OVER DRAINAGE DITCH  
 SN 086-0042 (EB) & 0043 (WB)**

F.A.I. RTE.	SECTION	COUNTY	TOTAL SHEETS	SHEET NO.
72	(86-8) BDR1,BJR1,BRR1,BP	SCOTT	45	34
CONTRACT NO. 72136				
ILLINOIS / FED. AID PROJECT				

SHEET NO. 1 OF 15 SHEETS

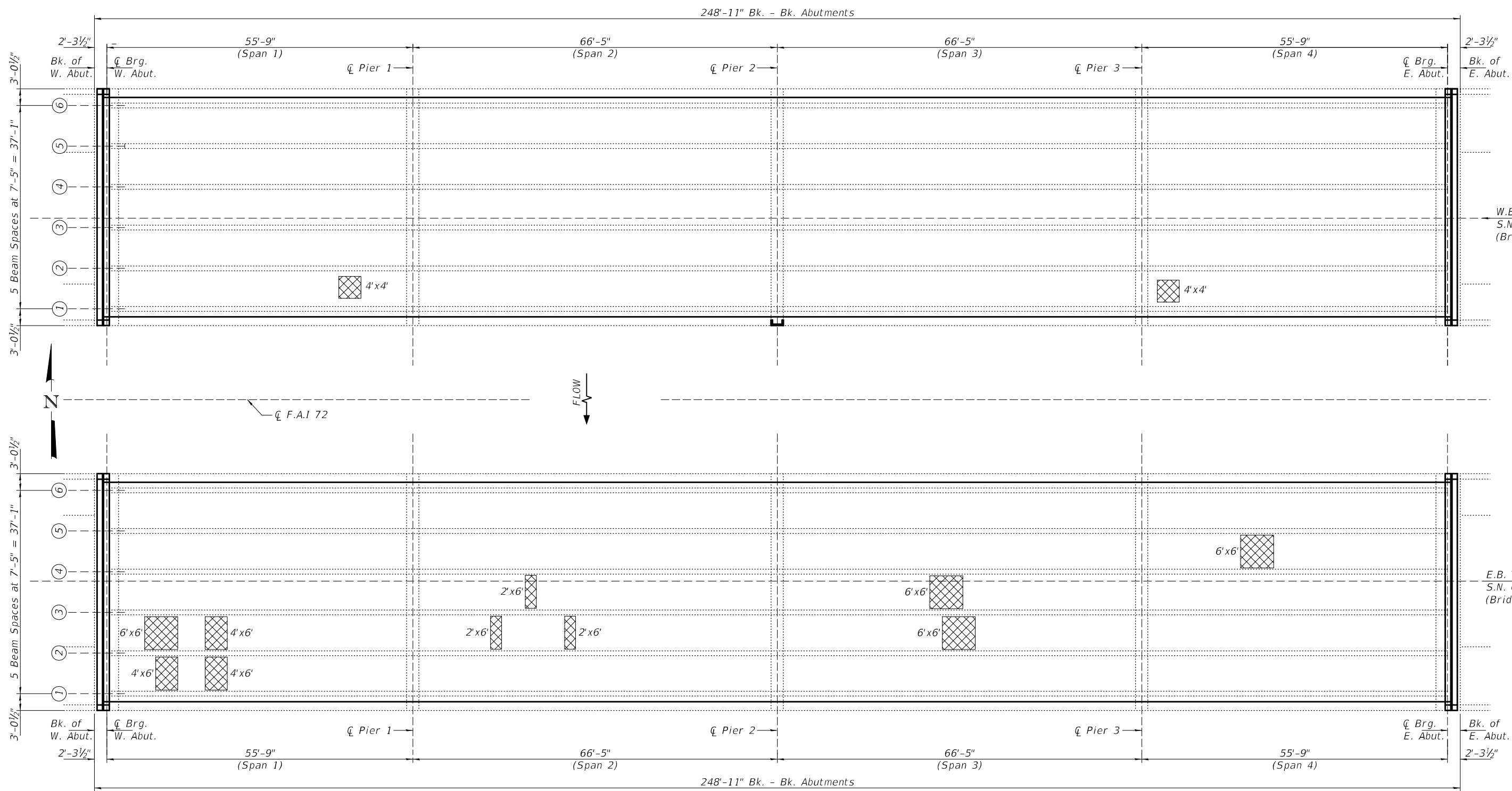

PLAN

**BILL OF MATERIAL  
(FOR INFORMATION ONLY)**

Deck Slab Repair (Full Depth, Type II)

Item	Unit	Total
Deck Slab Repair (Full Depth, Type II)	Sq. Yd.	32

DESIGNED - ATH  
 CHECKED - CCC  
 DRAWN - Venkat Ramana Reddy  
 CHECKED - ATH CCC

PASSED  
  
 ENGINEER OF BRIDGES AND STRUCTURES

DATE - February 2, 2023  
 REVISED -  
 REVISED -

**STATE OF ILLINOIS  
 DEPARTMENT OF TRANSPORTATION**

**DECK REPAIR DETAILS  
 SN 086-0042 (EB) & 0043 (WB)**

SHEET NO. 2 OF 15 SHEETS

F.A.I. RTE.	SECTION	COUNTY	TOTAL SHEETS	SHEET NO.
72	(86-8) BDR1,BJR1,BRR1,BP	SCOTT	45	35
CONTRACT NO. 72136				

ILLINOIS FED. AID PROJECT

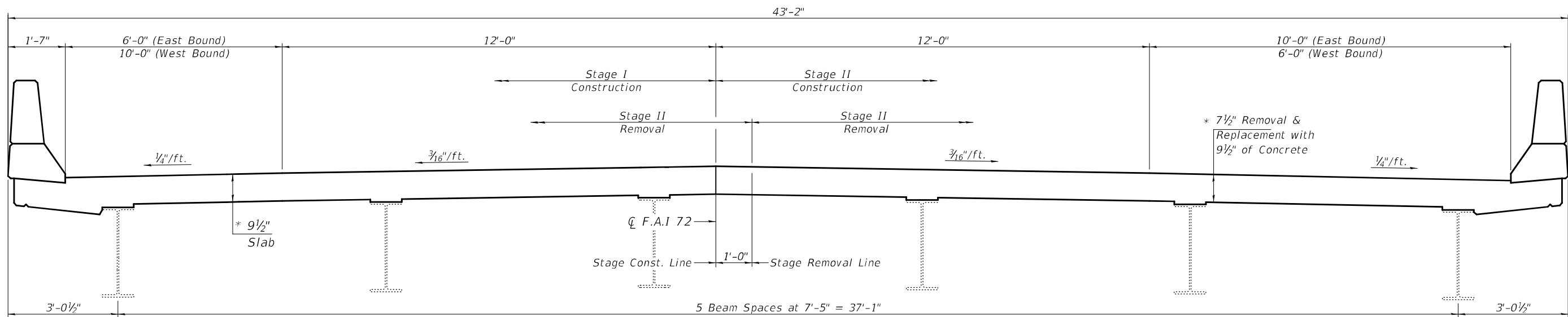

**CROSS SECTION AT ABUTMENTS**  
 (SN 086-0042 E.B. Looking East)  
 (SN 086-0043 W.B. Looking East)

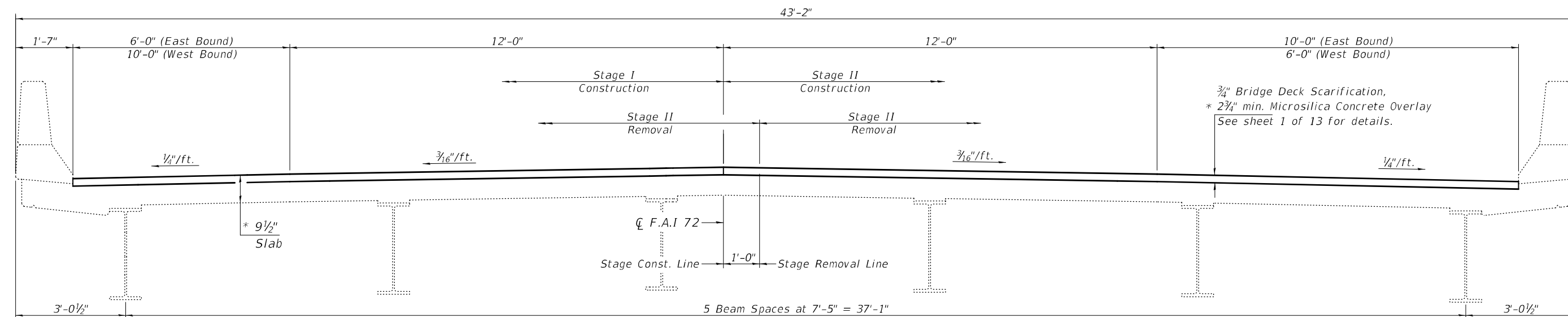

**CROSS SECTION AT MID SPAN**  
 (SN 086-0042 E.B. Looking East)  
 (SN 086-0043 W.B. Looking East)  
 \* Prior to 1/4" Diamond Grinding

3/4" Bridge Scarification  
 \* 2 3/4" min. Microsilica  
 Concrete Overlay. See  
 sheet 1 of 13 for details.

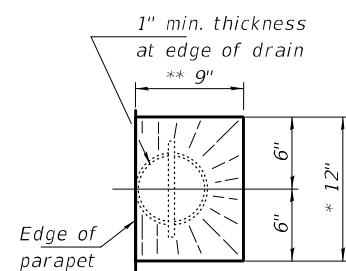

**DRAIN DETAIL**  
 \*\* slope to drain

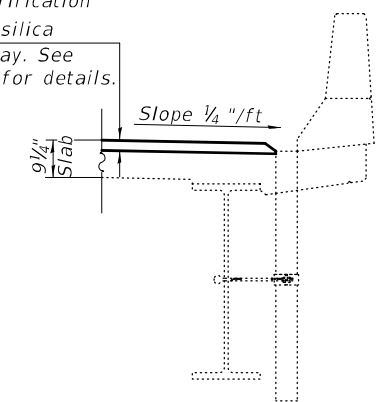

**SECTION THRU PARAPET**  
 (at drain)

DESIGNED - ATH
CHECKED - CCC
DRAWN - Venkat Ramana Reddy
CHECKED - ATH CCC

PASSED	<i>Joey F. [Signature]</i> ENGINEER OF BRIDGES AND STRUCTURES	DATE - February 2, 2023
		REVISED - REVISED -

**STATE OF ILLINOIS**  
**DEPARTMENT OF TRANSPORTATION**

**CROSS SECTIONS & STAGING DETAILS**  
**SN 086-0042 (EB) & 0043 (WB)**

F.A.I. RTE.	SECTION	COUNTY	TOTAL SHEETS	SHEET NO.
72	(86-8) BDR1,BJR1,BRR1,BP	SCOTT	45	36
CONTRACT NO. 72136				
ILLINOIS FED. AID PROJECT				

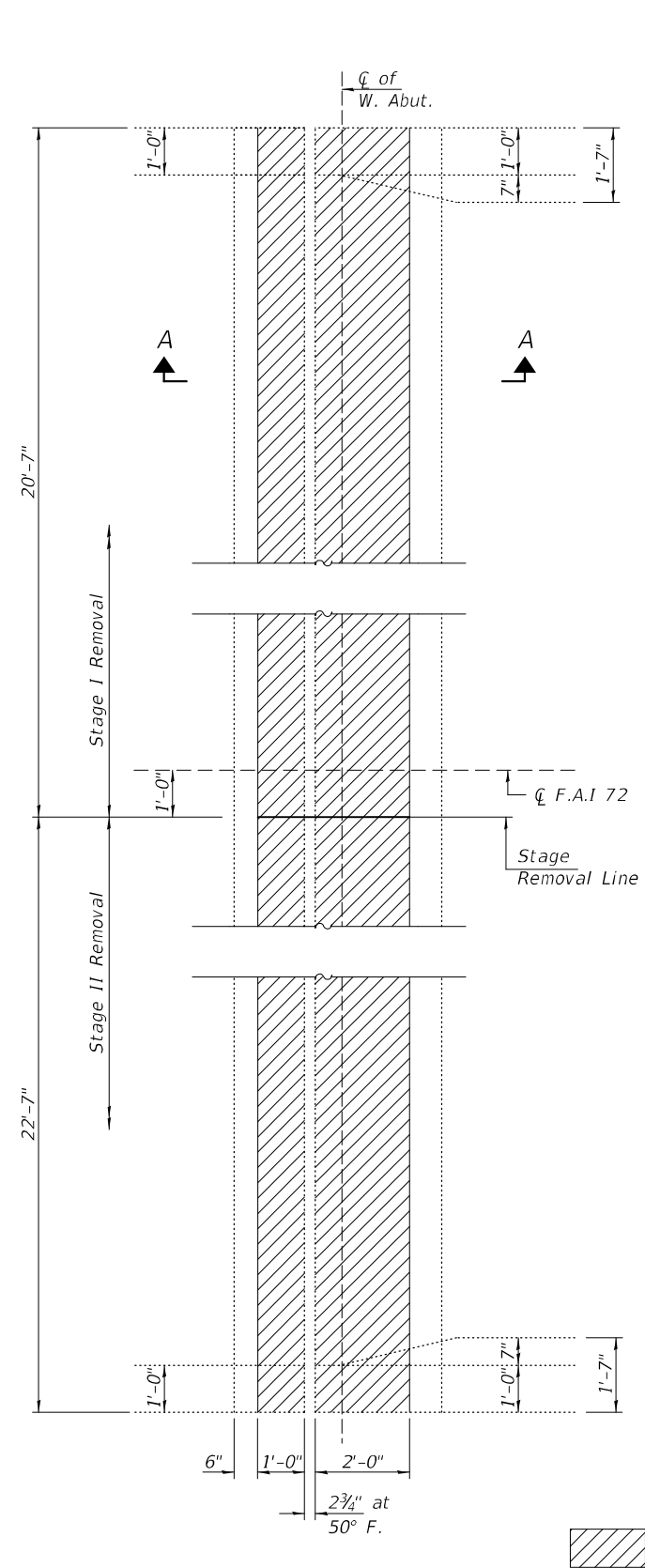

**REMOVAL PLAN**

West Abut. shown, East Abut. similar by mirroring along  $\bar{C}$  Pier 2

Concrete Removal

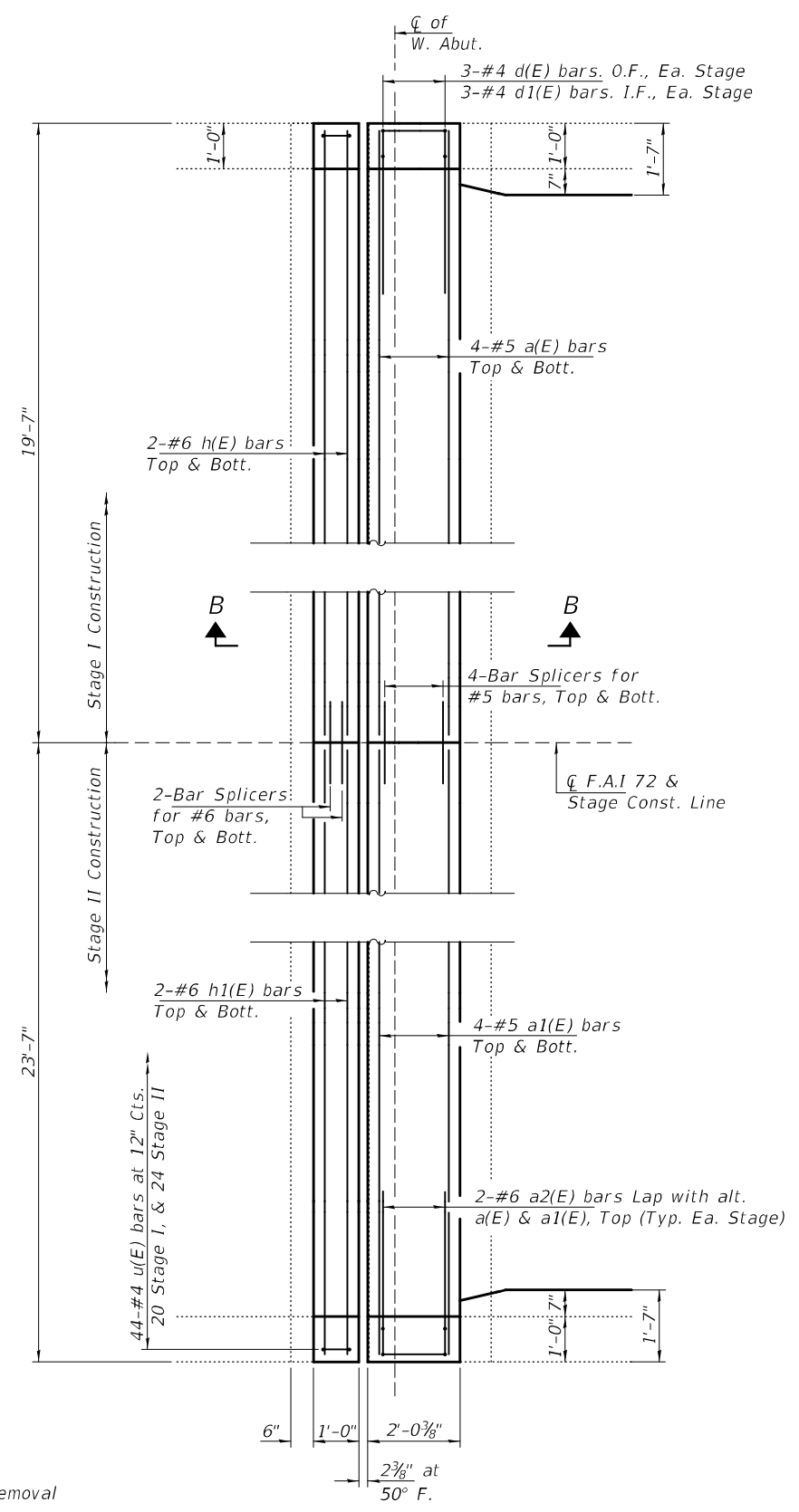

**REPLACEMENT PLAN**

West Abut. shown, East Abut. similar by mirroring along  $\bar{C}$  Pier 2

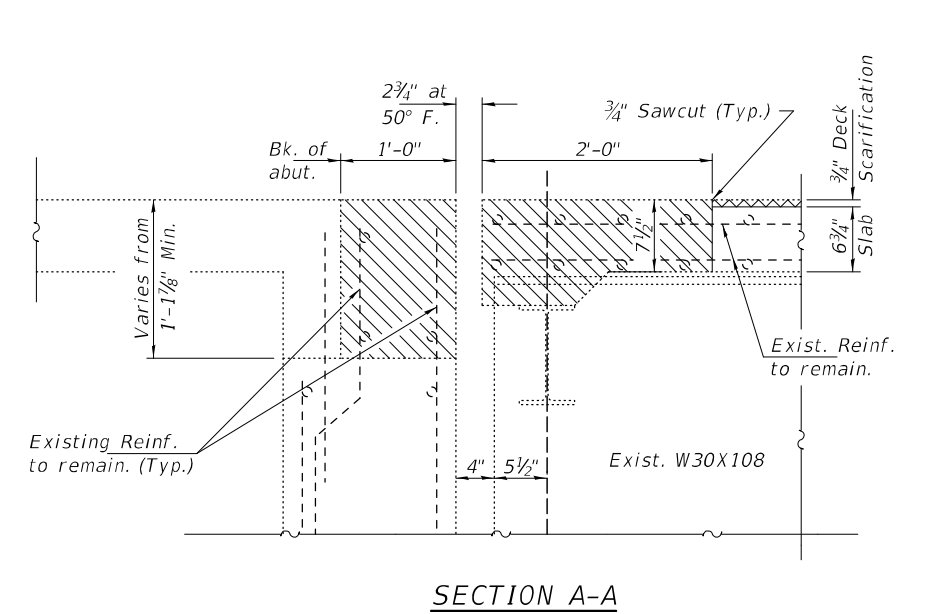

**SECTION A-A**

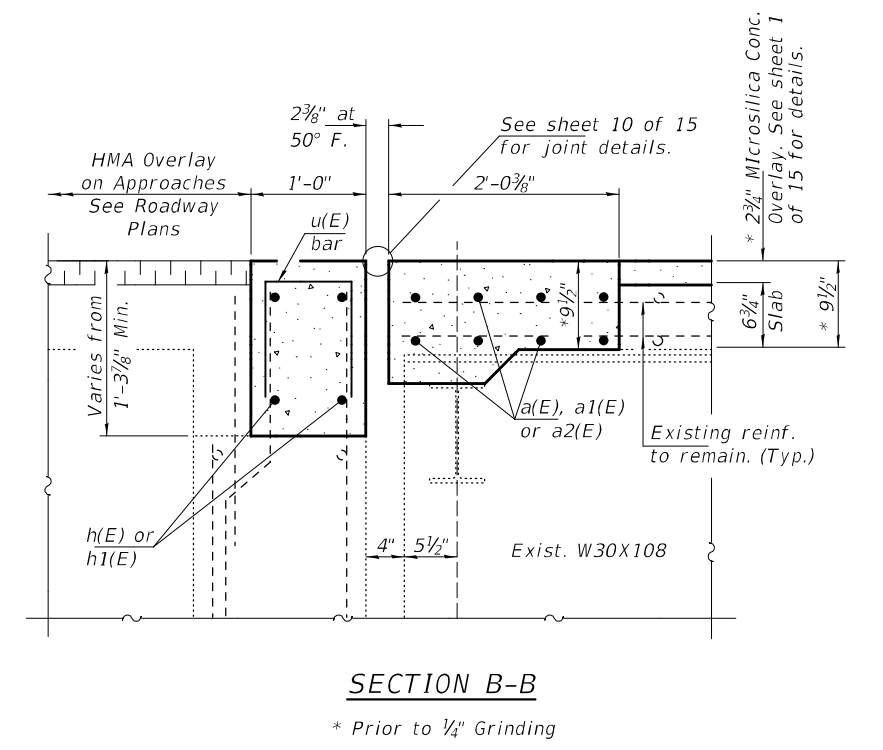

**SECTION B-B**

\* Prior to 1/4" Grinding

Note: See Sheet 6 of 15 for Reinforcement and Parapet Details.

DESIGNED - ATH	PASSED  ENGINEER OF BRIDGES AND STRUCTURES	DATE - February 2, 2023	<b>STATE OF ILLINOIS DEPARTMENT OF TRANSPORTATION</b>	<b>JOINT REMOVAL &amp; REPLACEMENT DETAILS SN 086-0042 (EB)</b>	F.A.I. RTE.	SECTION	COUNTY	TOTAL SHEETS	SHEET NO.
CHECKED - CCC		REVISED -			72	(86-8) BDR1,BJR1,BRR1,BP	SCOTT	45	37
DRAWN - Venkat Ramana Reddy		REVISED -			CONTRACT NO. 72136				
CHECKED - ATH CCC		SHEET NO. 4 OF 15 SHEETS			ILLINOIS FED. AID PROJECT				

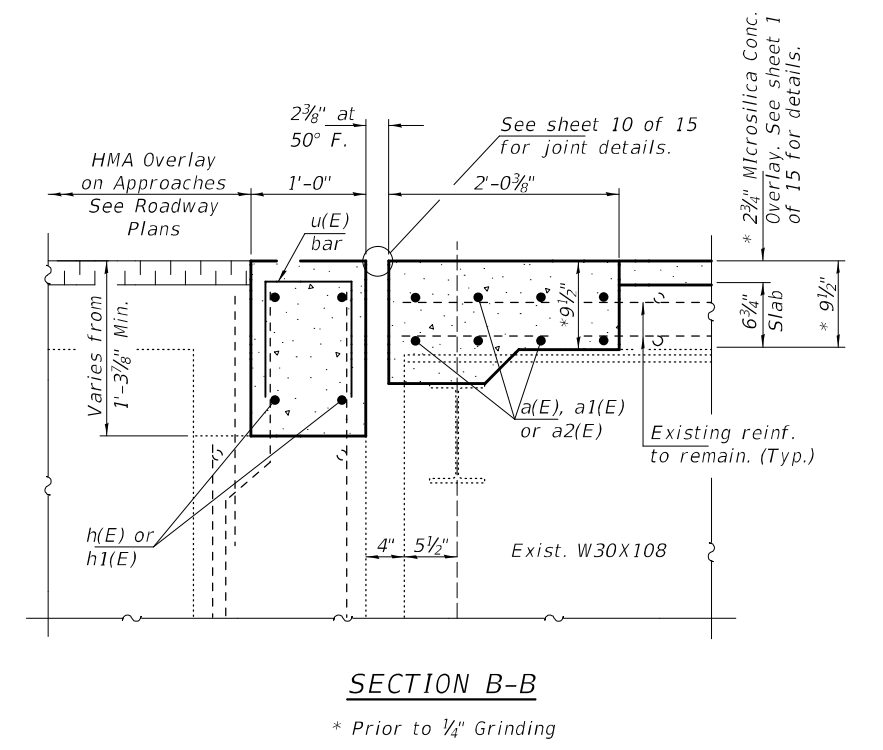
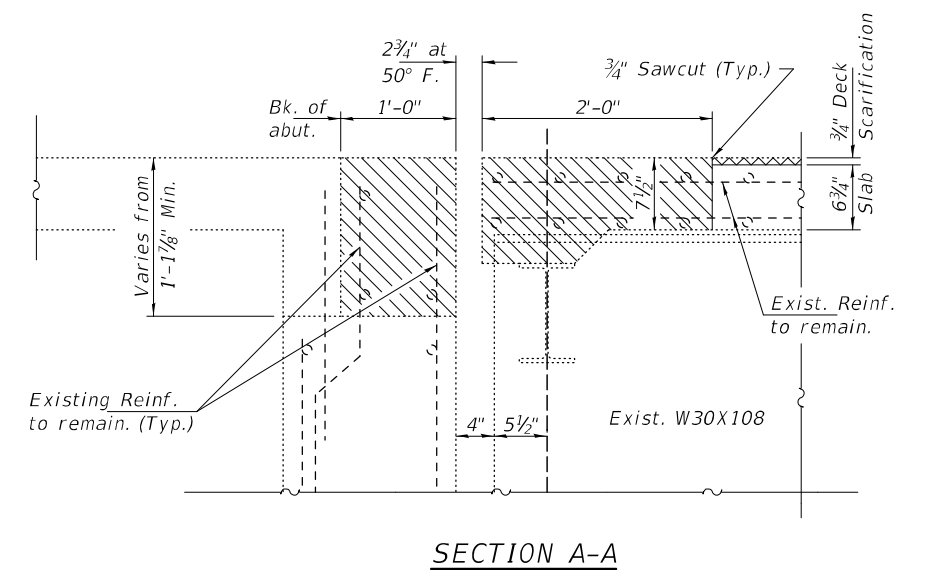
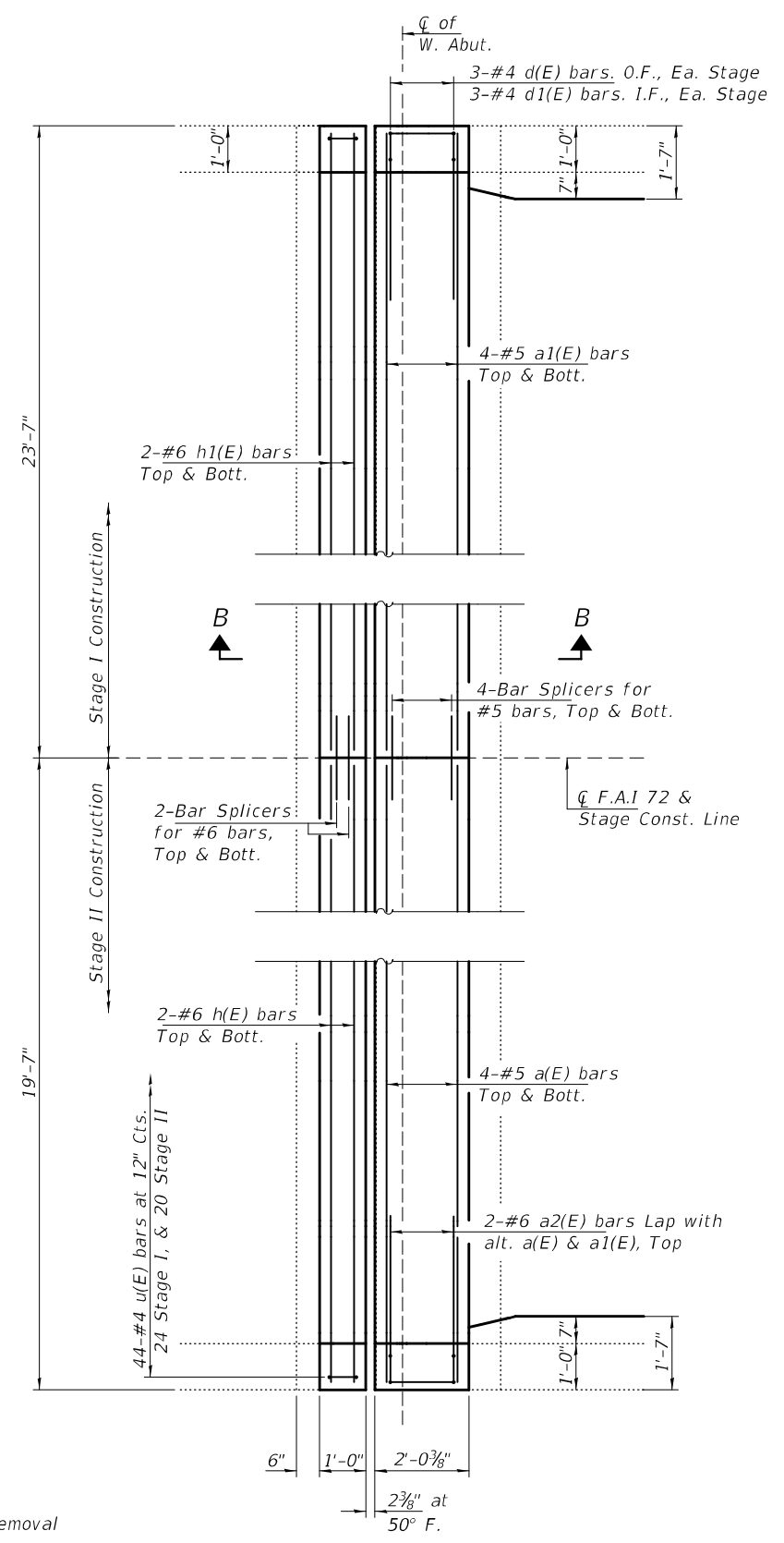
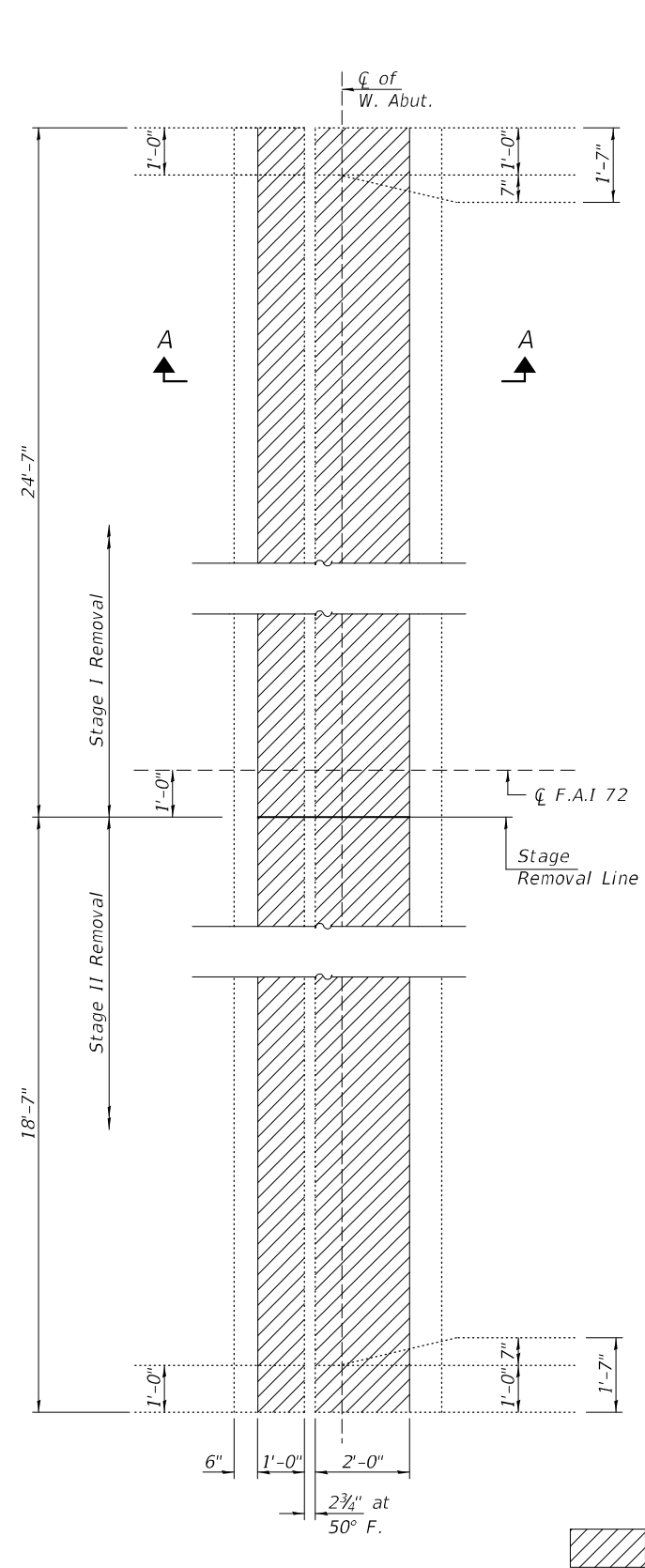

Note:  
See Sheet 6 of 15 for Reinforcement and Parapet Details.

DESIGNED - ATH		DATE - February 2, 2023	<b>STATE OF ILLINOIS DEPARTMENT OF TRANSPORTATION</b>	<b>JOINT REMOVAL &amp; REPLACEMENT DETAILS SN 086-0043 (WB)</b>	SHEET NO. 5 OF 15 SHEETS
CHECKED - CCC					
DRAWN - Venkat Ramana Reddy	PASSED	<i>Joanna F. [Signature]</i> ENGINEER OF BRIDGES AND STRUCTURES			
CHECKED - ATH CCC		REVISED - REVISED -		F.A.I. RTE. 72 SECTION (86-8) BDR1,BJR1,BRR1,BP COUNTY SCOTT TOTAL SHEETS 45 SHEET NO. 38 CONTRACT NO. 72136	ILLINOIS FED. AID PROJECT

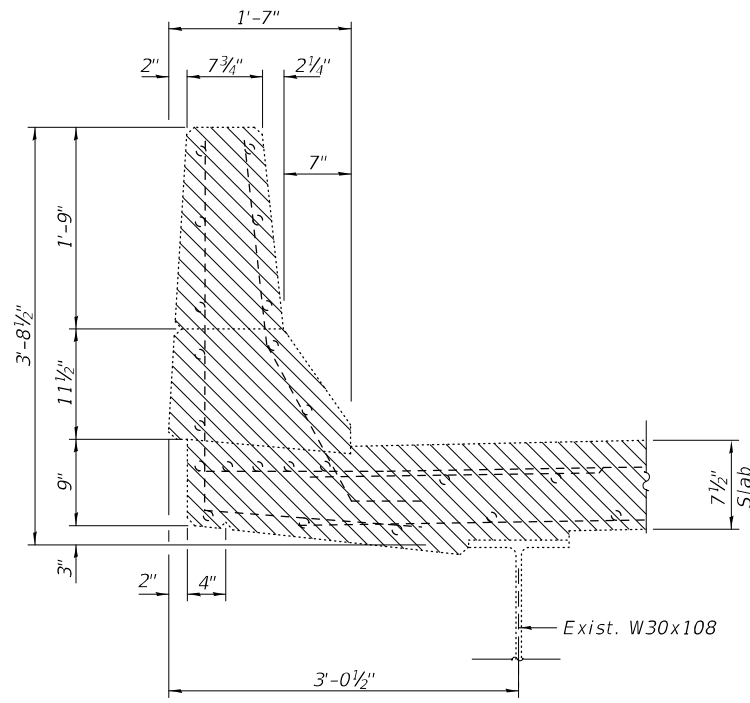

**REMOVAL DETAILS**

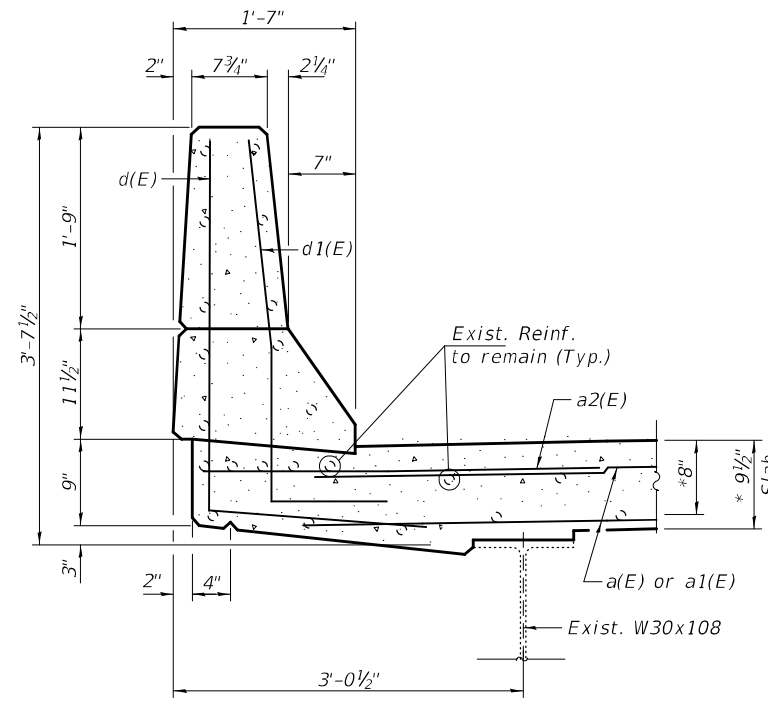

**REPLACEMENT DETAILS**

\* Prior to 1/4" Grinding

**SECTION THRU BRIDGE PARAPET AT BOTH ABUTMENTS**

Concrete Replacement

Concrete Replacement

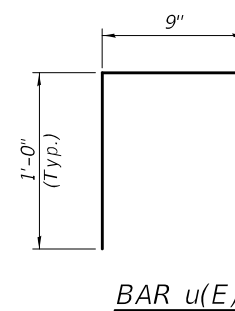
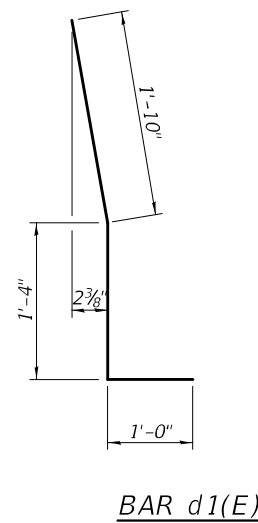
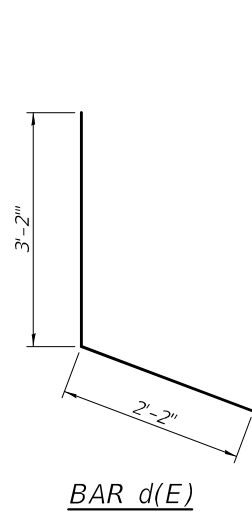

**BILL OF MATERIAL**

Bar	No.	Size	Length	Shape
a(E)	32	#5	18'-6"	—
a1(E)	32	#5	22'-6"	—
a2(E)	16	#6	4'-0"	—
d(E)	24	#4	5'-4"	L
d1(E)	24	#5	4'-2"	L
h(E)	16	#6	19'-3"	—
h1(E)	16	#6	23'-3"	—
u(E)	176	#4	2'-9"	U
Concrete Removal			Cu. Yd.	21.5
Concrete Superstructure			Cu. Yd.	25.0
Protective Coat			Sq. Yd.	2222
Bar Splicers			Each	48
Reinforcement Bars, Epoxy Coated			Pound	3000

DESIGNED - ATH  
 CHECKED - CCC  
 DRAWN - Venkat Ramana Reddy  
 CHECKED - ATH CCC

PASSED

*Jaime F. J. [Signature]*  
 ENGINEER OF BRIDGES AND STRUCTURES

DATE - February 2, 2023

REVISED -  
 REVISED -

**STATE OF ILLINOIS  
 DEPARTMENT OF TRANSPORTATION**

**JOINT REMOVAL & REPLACEMENT DETAILS  
 SN 086-0042 (EB) & 0043 (WB)**

SHEET NO. 6 OF 15 SHEETS

F.A.I. RTE.	SECTION	COUNTY	TOTAL SHEETS	SHEET NO.
72	(86-8) BDR1,BJR1,BRR1,BP	SCOTT	45	39
CONTRACT NO. 72136				
ILLINOIS FED. AID PROJECT				

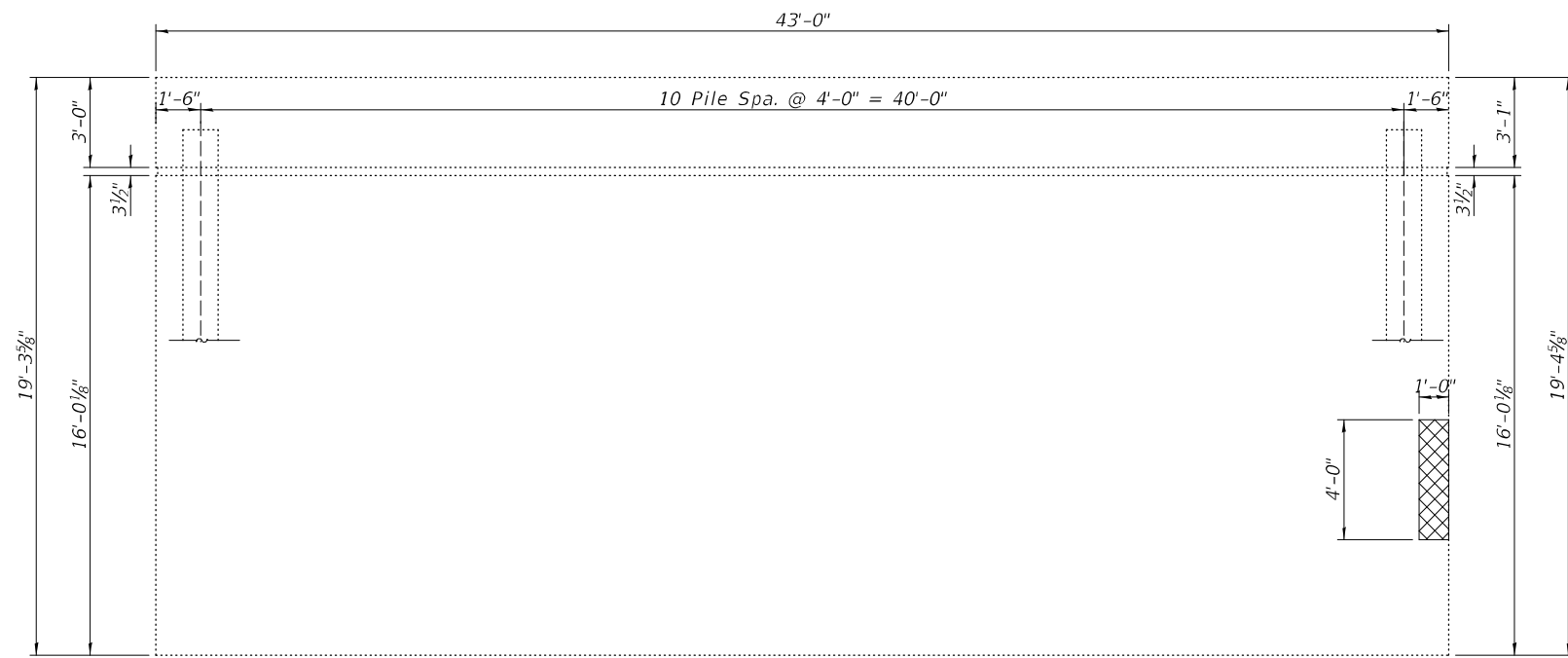

**ELEVATION**  
(Looking East)

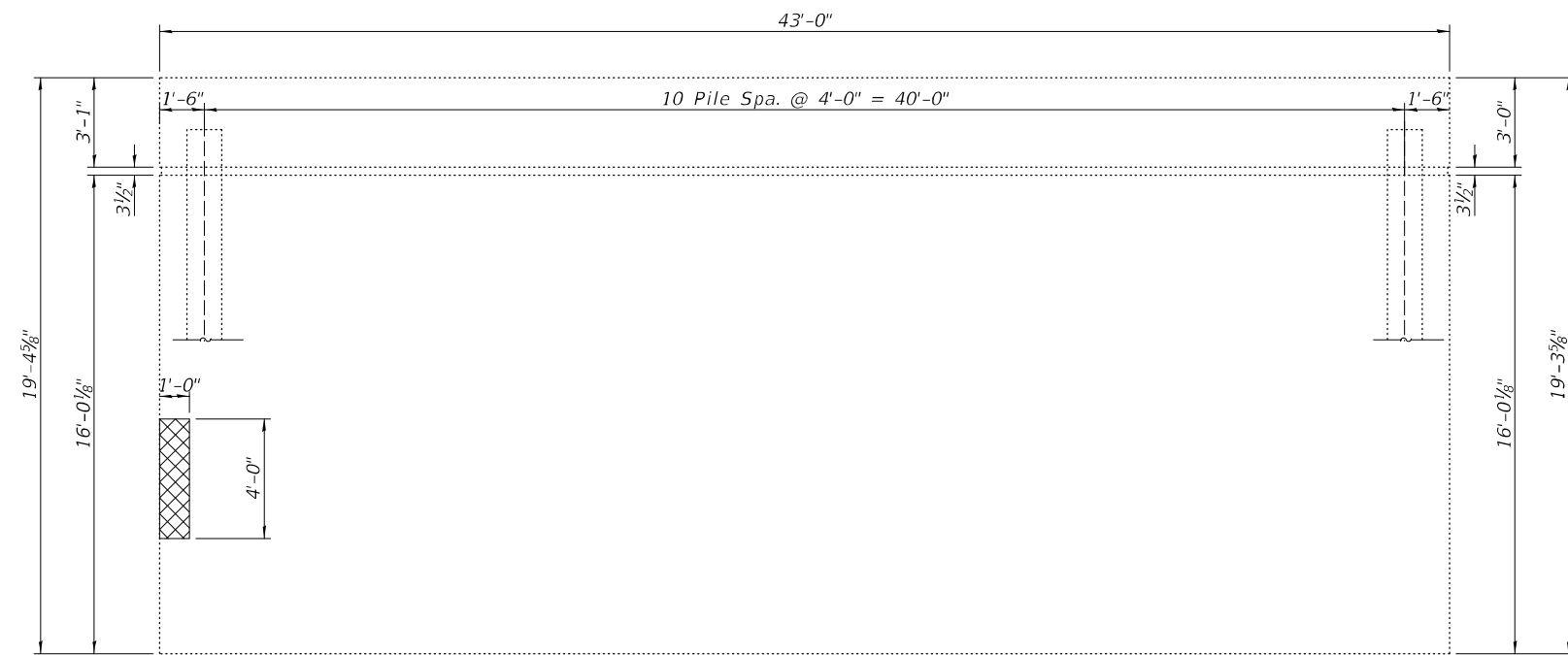

**ELEVATION**  
(Looking West)

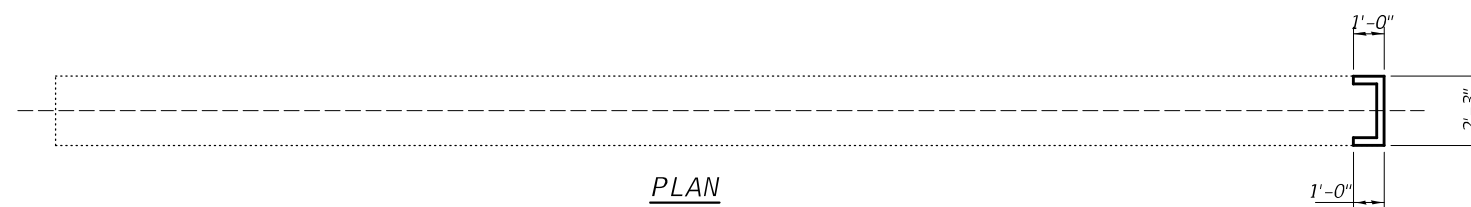

**PLAN**

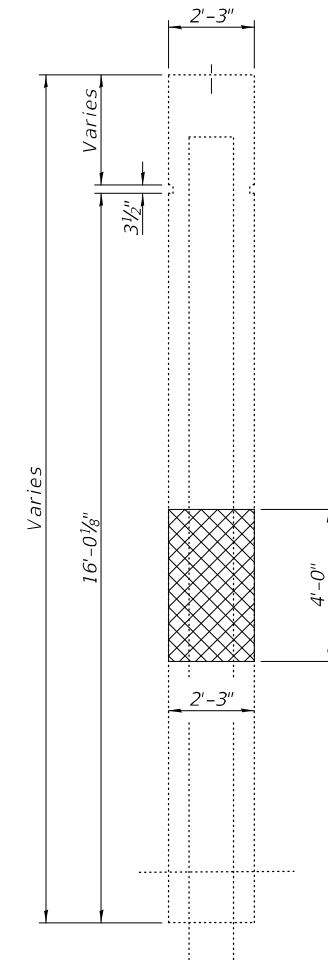

**END VIEW-SOUTH SIDE**  
(Looking North)

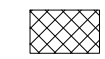
 Structural Repair of Concrete (Depth  $\leq$  5")

**BILL OF MATERIAL**

Item	Unit	Quantity
Structural Repair of Concrete (Depth $\leq$ 5")	Sq. Ft.	17

DESIGNED - ATH  
CHECKED - CCC  
DRAWN - Venkat Ramana Reddy  
CHECKED - ATH CCC

PASSED

  
ENGINEER OF BRIDGES AND STRUCTURES

DATE - February 2, 2023

REVISED -  
REVISED -

**STATE OF ILLINOIS**  
**DEPARTMENT OF TRANSPORTATION**

**PIER 2 REPAIR DETAILS**  
**SN 086-0043 (WB)**

SHEET NO. 7 OF 15 SHEETS

F.A.I. RTE.	SECTION	COUNTY	TOTAL SHEETS	SHEET NO.
72	(86-8) BDR1,BJR1,BRR1,BP	SCOTT	45	40
				CONTRACT NO. 72136
				ILLINOIS FED. AID PROJECT



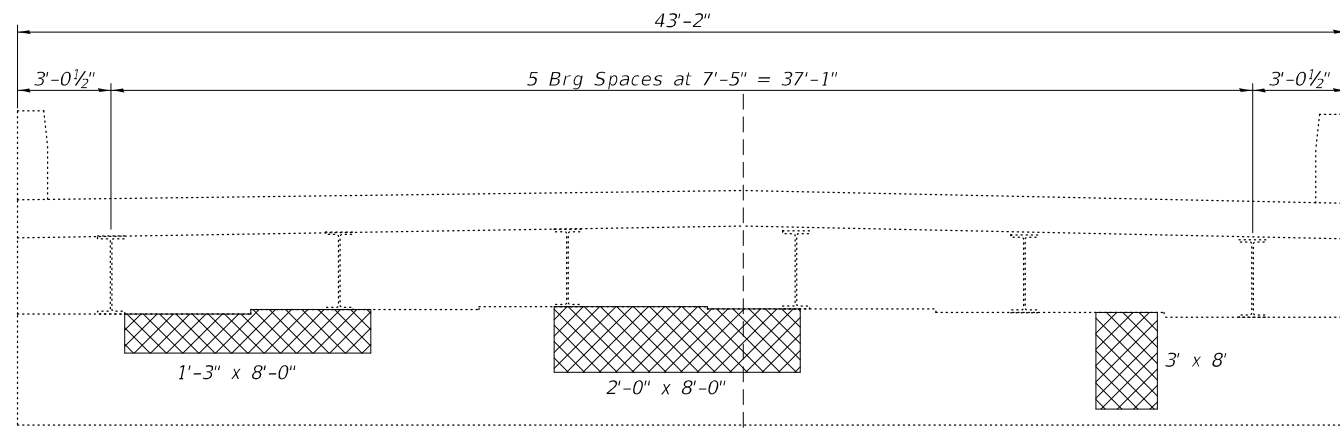

**E. ABUT. ELEVATION**  
(Looking East)

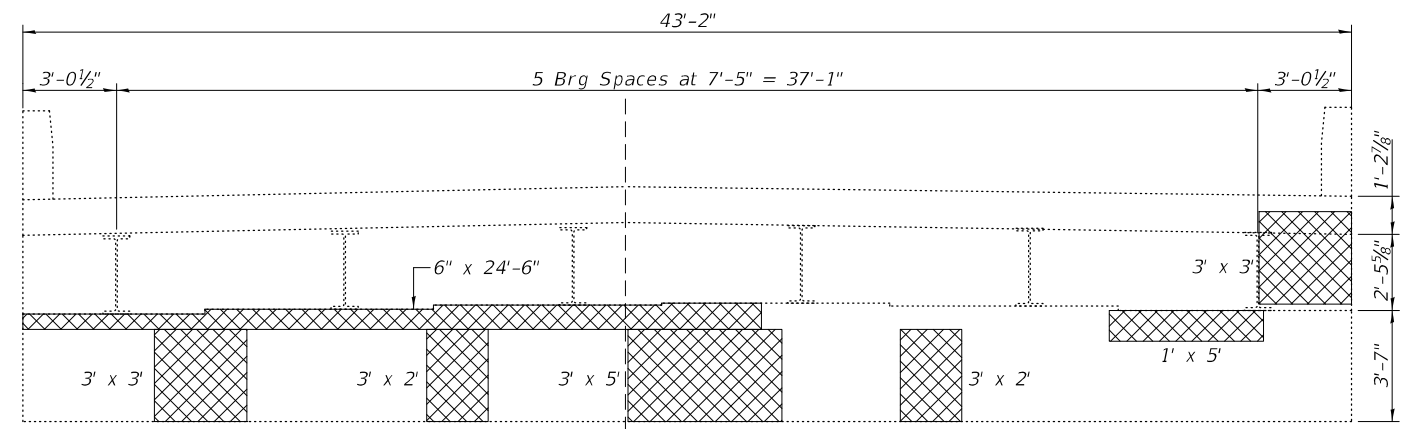

**W. ABUT. ELEVATION**  
(Looking West)

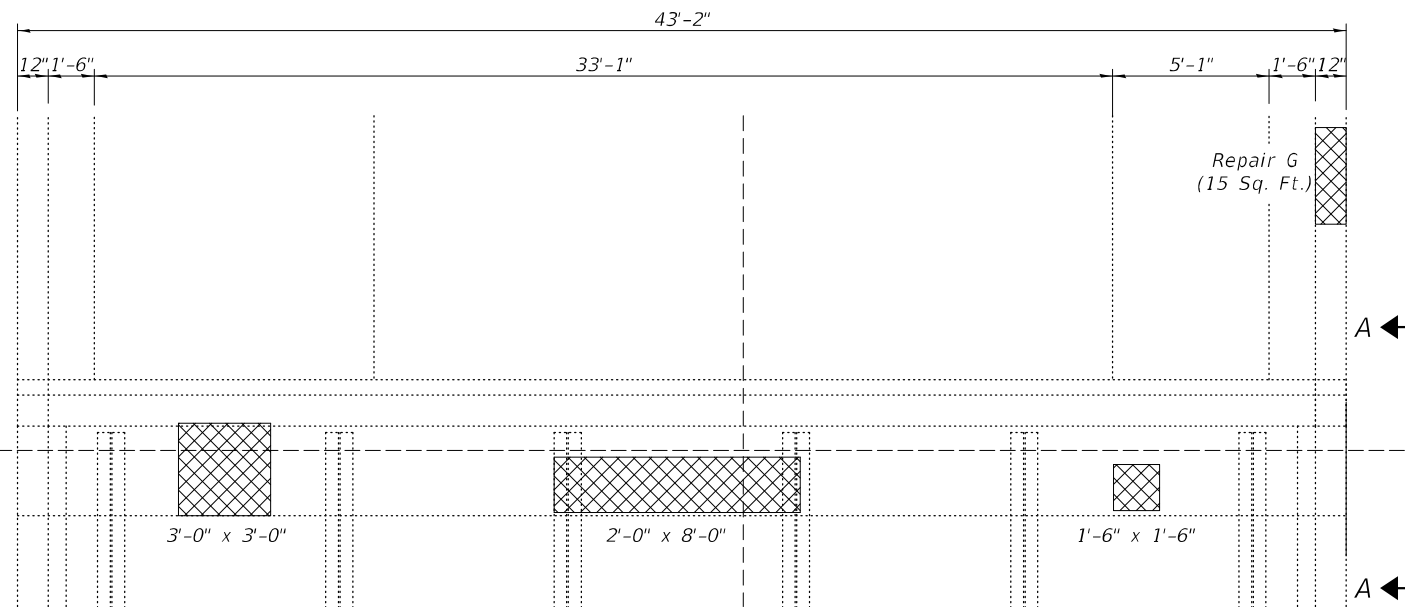

**E. ABUT. PLAN**

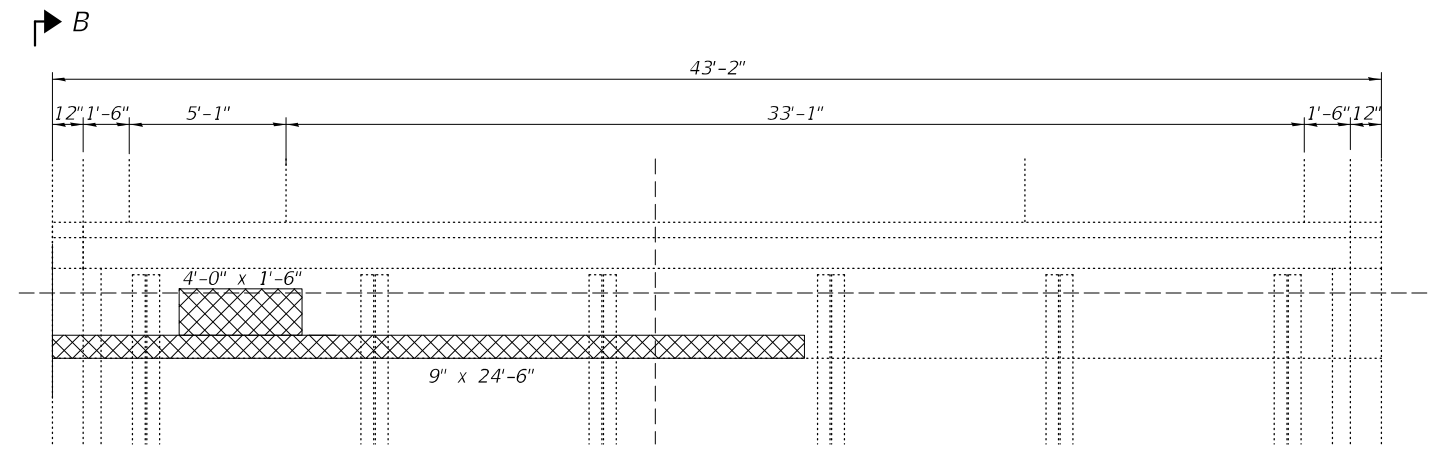

**W. ABUT. PLAN**

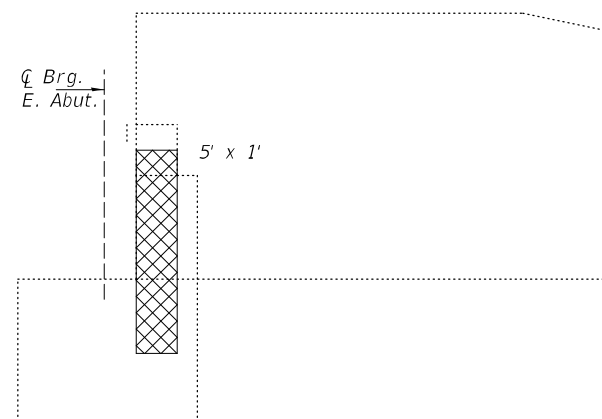

**SECTION A-A**

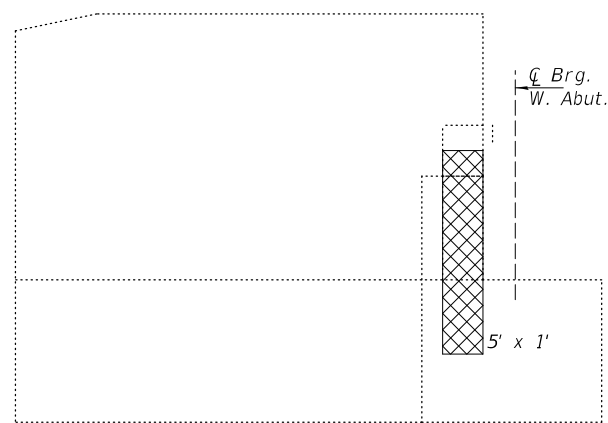

**SECTION B-B**

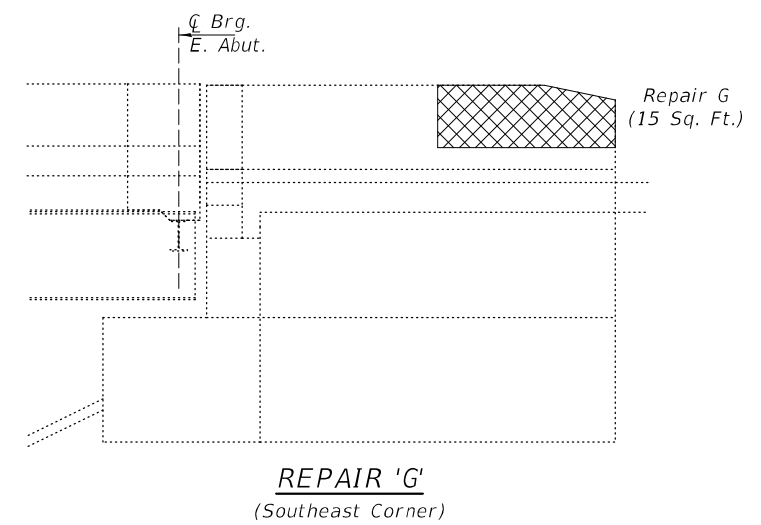

**REPAIR 'G'**  
(Southeast Corner)

Structural Repair of Concrete (Depth ≤ 5")

**BILL OF MATERIAL**

Item	Unit	Quantity
Structural Repair of Concrete (Depth ≤ 5")	Sq. Ft.	189

DESIGNED - ATH  
CHECKED - CCC  
DRAWN - Venkat Ramana Reddy  
CHECKED - ATH CCC

PASSED

*Joanna F. [Signature]*  
ENGINEER OF BRIDGES AND STRUCTURES

DATE - February 2, 2023

REVISED -  
REVISED -

**STATE OF ILLINOIS**  
**DEPARTMENT OF TRANSPORTATION**

**ABUTMENTS REPAIR DETAILS**  
**SN 086-0043 (WB)**

SHEET NO. 8 OF 15 SHEETS

F.A.I. RTE.	SECTION	COUNTY	TOTAL SHEETS	SHEET NO.
72	(86-8) BDR1,BJR1,BRR1,BP	SCOTT	45	41
CONTRACT NO. 72136				
ILLINOIS FED. AID PROJECT				

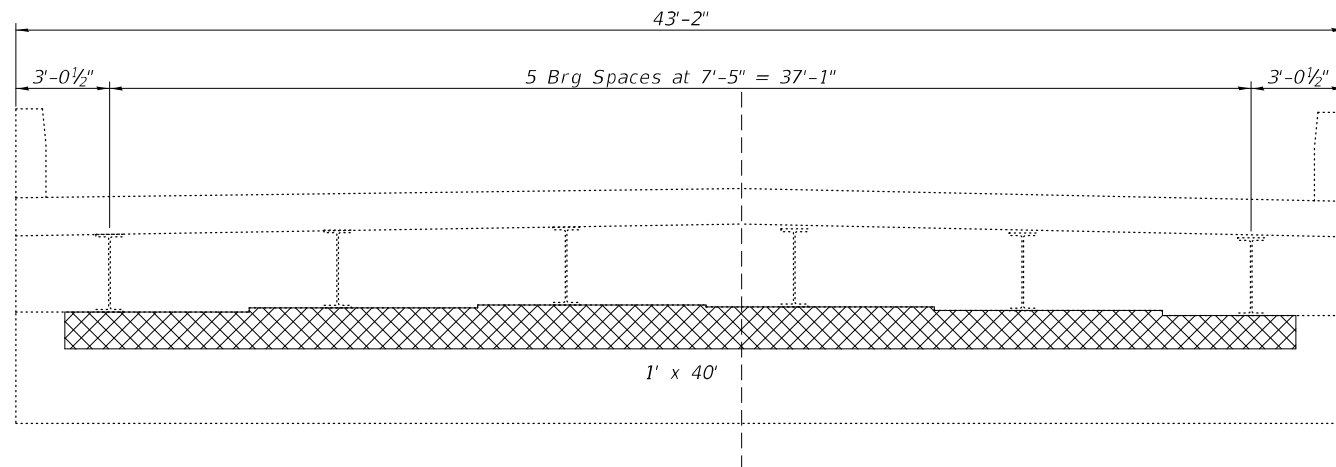

W. ABUT. ELEVATION

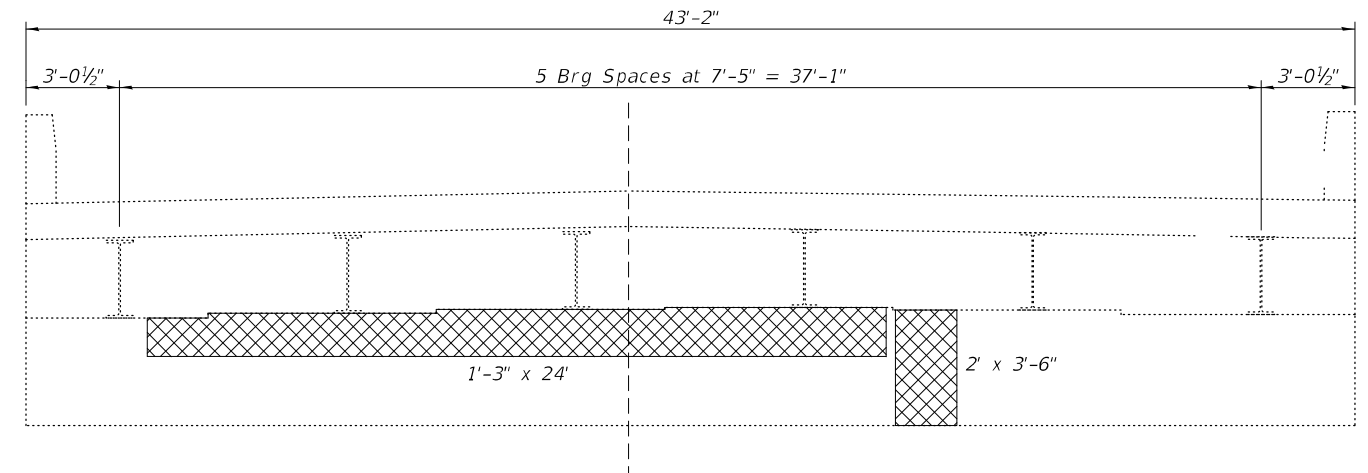

E. ABUT. ELEVATION

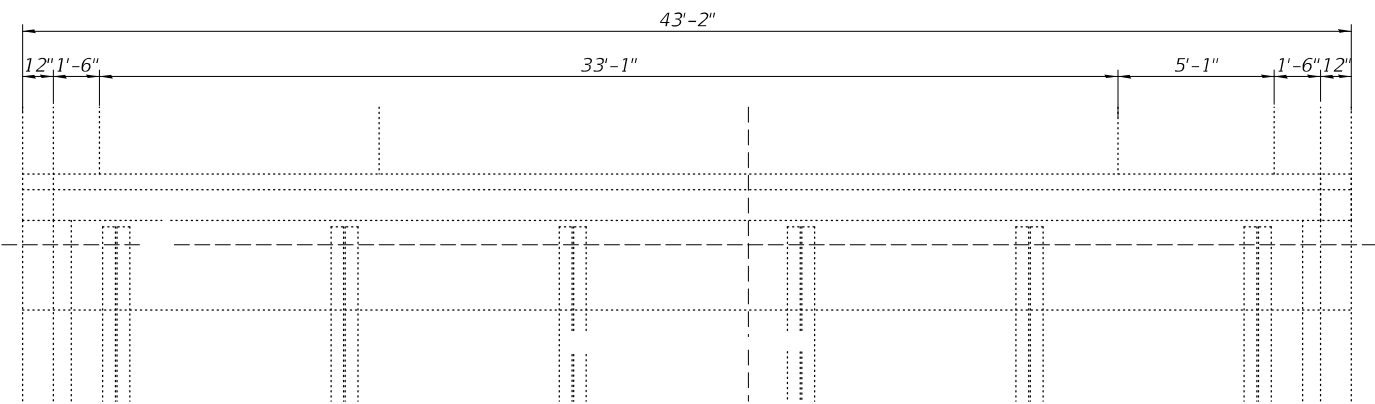

W. ABUT. PLAN

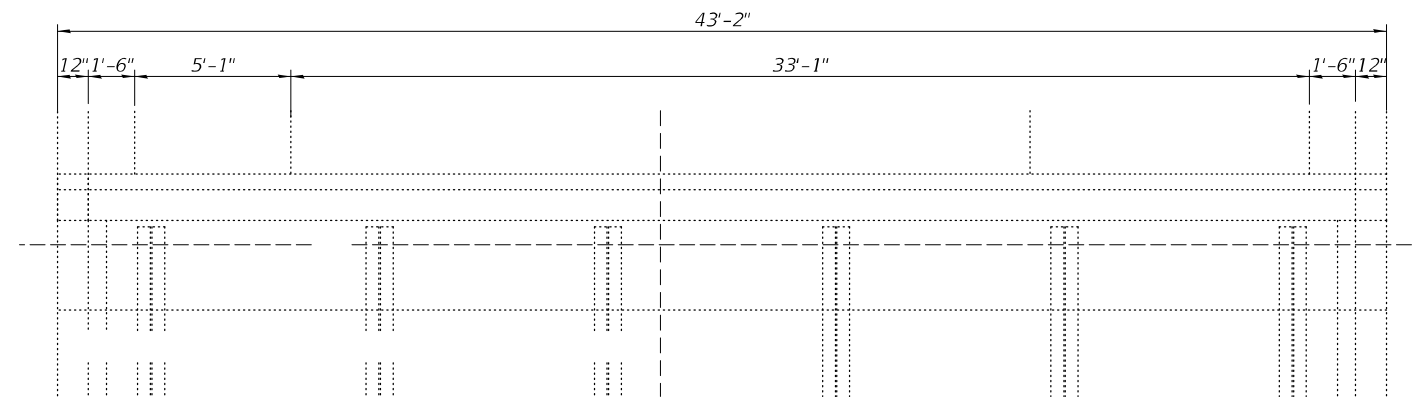

E. ABUT. PLAN

 Structural Repair of Concrete (Depth ≤ 5")

**BILL OF MATERIAL**

Item	Unit	Quantity
Structural Repair of Concrete (Depth ≤ 5")	Sq. Ft.	77

DESIGNED - ATH  
 CHECKED - CCC  
 DRAWN - Venkat Ramana Reddy  
 CHECKED - ATH CCC

PASSED

  
 ENGINEER OF BRIDGES AND STRUCTURES

DATE - February 2, 2023

REVISED -  
 REVISED -

**STATE OF ILLINOIS  
 DEPARTMENT OF TRANSPORTATION**

**ABUTMENTS REPAIR DETAILS  
 SN 086-0042 (EB)**

SHEET NO. 9 OF 15 SHEETS

F.A.I. RTE.	SECTION	COUNTY	TOTAL SHEETS	SHEET NO.
72	(86-8) BDR1,BJR1,BRR1,BP	SCOTT	45	42
CONTRACT NO. 72136				
ILLINOIS FED. AID PROJECT				

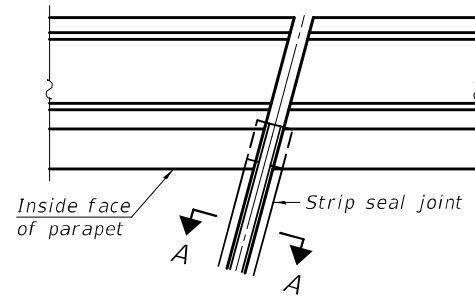

FOR SKEWS  $\leq 30^\circ$   
**PLAN AT PARAPET**

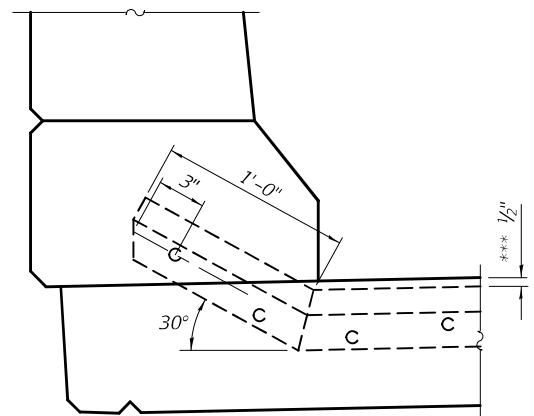

**PARAPET ELEVATION AT ABUTMENTS**  
 (Skews  $\leq 30^\circ$ )

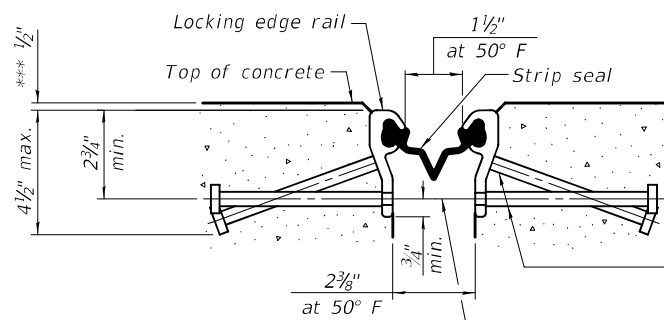

**SHOWING ROLLED RAIL JOINT**

\*  $\frac{5}{8}$ "  $\varnothing$  x 6" studs @ 6" cts. (alternate angled/bent studs with horizontal studs)  
 $\frac{3}{8}$ "  $\varnothing$  threaded rods in  $\frac{1}{16}$ "  $\varnothing$  holes at  $\pm 4$ "-0" cts. for holding the proper joint opening based on the temperature during the deck pour. Place to miss studs. All rods shall be burned, or sawed off flush with the plates after concrete is set.

**SECTION A-A**

\* Granular or solid flux filled headed studs conforming to Article 1006.32 of the Std. Specs., automatically end welded.

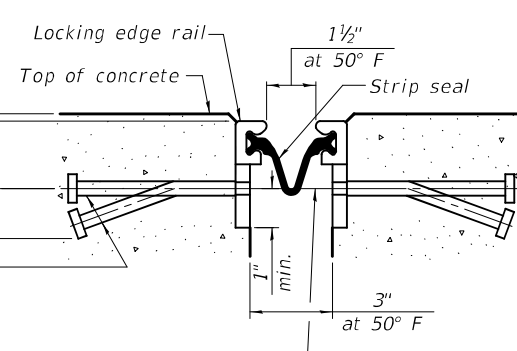

**SHOWING WELDED RAIL JOINT**

\*\*\*Prior to  $\frac{1}{4}$ " Grinding

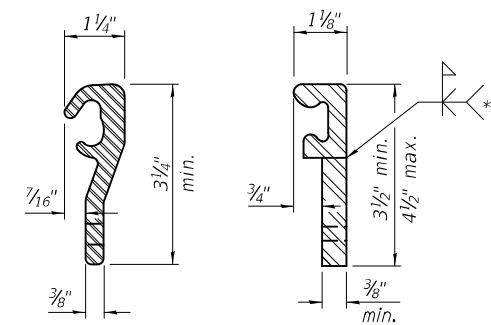

**LOCKING EDGE RAILS**

\*\* Back gouge not required if complete joint penetration is verified by mock-up.

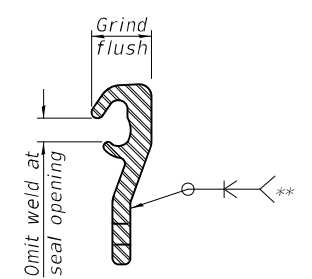

**LOCKING EDGE RAIL SPLICE**

The inside of the locking edge rail groove shall be free of weld residue. Rolled rail shown, welded rail similar.

**BILL OF MATERIAL**

Item	Unit	Total
Preformed Joint Strip Seal	Foot	168

EJ-SS1 LT30/REPS

2-25-20

DESIGNED - ATH
CHECKED - CCC
DRAWN - Venkat Ramana Reddy
CHECKED - ATH CCC

PASSED

*Joym F. J. [Signature]*  
 ENGINEER OF BRIDGES AND STRUCTURES

DATE - February 2, 2023

REVISED -
REVISED -

STATE OF ILLINOIS  
 DEPARTMENT OF TRANSPORTATION

PREFORMED JOINT STRIP SEAL  
 SN 086-0042 (EB) & 0043 (WB)

SHEET NO. 10 OF 15 SHEETS

F.A.I. RTE.	SECTION	COUNTY	TOTAL SHEETS	SHEET NO.
72	(86-8) BDR1,BJR1,BRR1,BP	SCOTT	45	43
CONTRACT NO. 72136				
ILLINOIS FED. AID PROJECT				

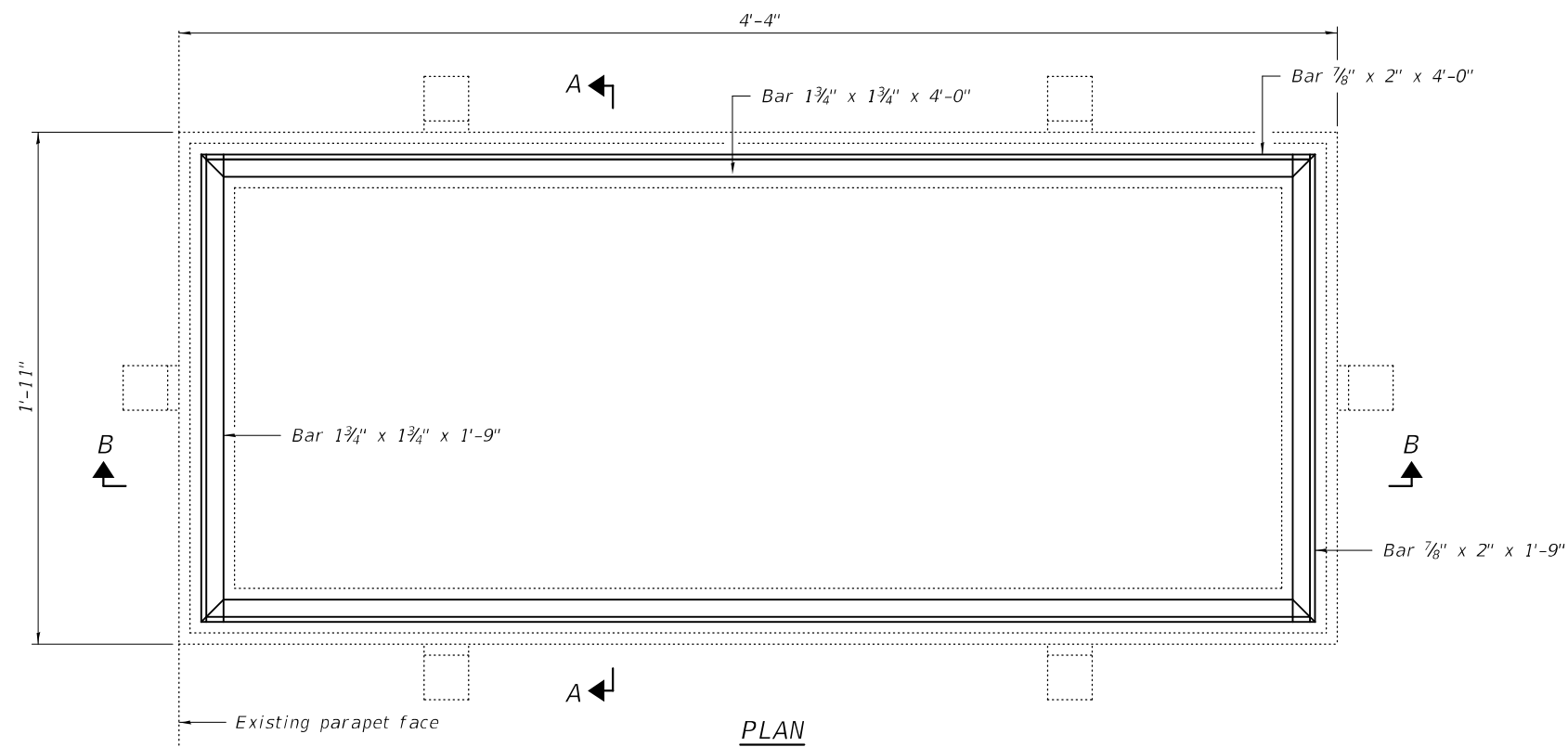

Notes:  
 The contractor shall ensure that no damage is done to existing grates to be reused.  
 Shop plans for proposed adjusting inlet ring shall be submitted for approval prior to fabrication.  
 Cost of all labor and materials necessary to remove existing grates, clean existing inlets, install adjusting inlet rings and reinstalling grates is included in the cost per unit each for Inlets to be Adjusted.  
 All structural steel shall conform to AASHTO Classification M-270 Gr. 36.  
 The adjusting inlet ring shall be galvanized.  
 Bolts shall be 1/2"Ø, AASHTO M164 Type I, mechanically galvanized.

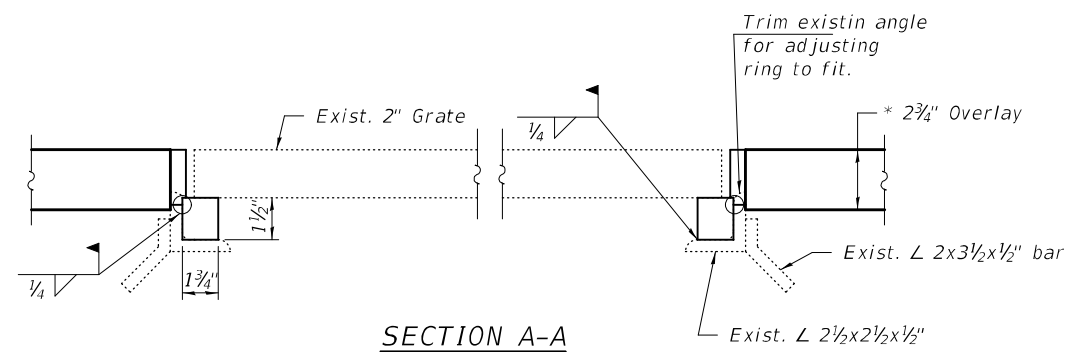

SECTION A-A

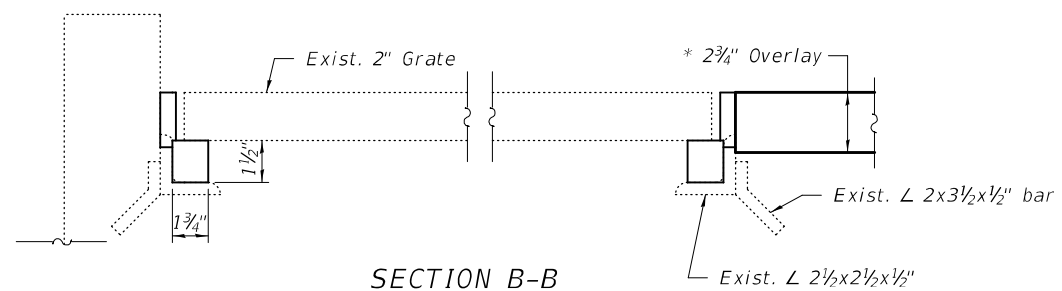

SECTION B-B

\* Prior to grinding

BILL OF MATERIAL

Item	Unit	Total
Inlets to be Adjusted	Each	8

DESIGNED - ATH  
 CHECKED - CCC  
 DRAWN - Venkat Ramana Reddy  
 CHECKED - ATH CCC

PASSED

*Joym F. Joffe*  
 ENGINEER OF BRIDGES AND STRUCTURES

DATE - February 2, 2023

REVISED -  
 REVISED -

STATE OF ILLINOIS  
 DEPARTMENT OF TRANSPORTATION

INLET ADJUSTMENT DETAILS  
 SN 086-0042 (EB) & 0043 (WB)

SHEET NO. 11 OF 15 SHEETS

F.A.I. RTE.	SECTION	COUNTY	TOTAL SHEETS	SHEET NO.
72	(86-8) BDR1,BJR1,BRR1,BP	SCOTT	45	44
CONTRACT NO. 72136				
ILLINOIS FED. AID PROJECT				

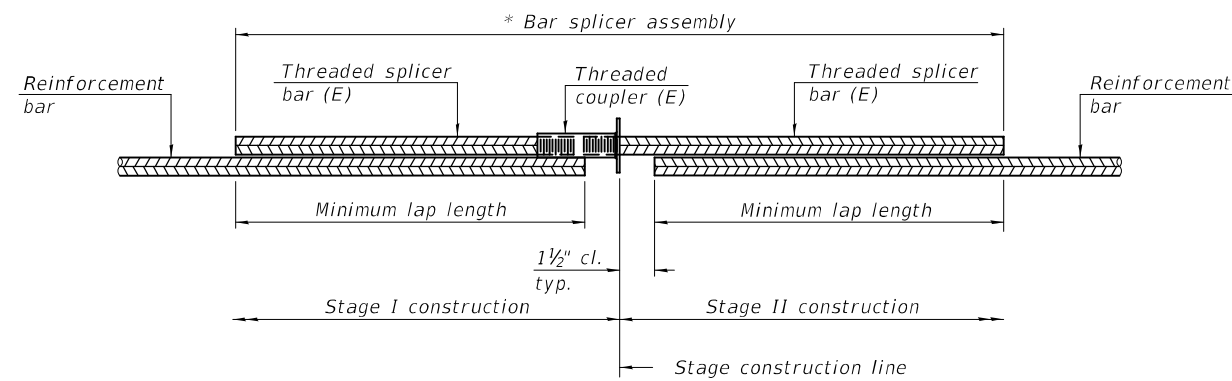

**STANDARD BAR SPLICER ASSEMBLY PLAN**  
(All components shall be provided from one supplier)

Threaded splicer bar length = min. lap length + 1 1/2" + thread length

\* Epoxy not required on Bar Splicer Assembly components used in conjunction with black bars.

Location	Bar size	No. assemblies required	Minimum lap length
Deck	#5	32	3'-6"
Abutment	#6	16	4'-0"

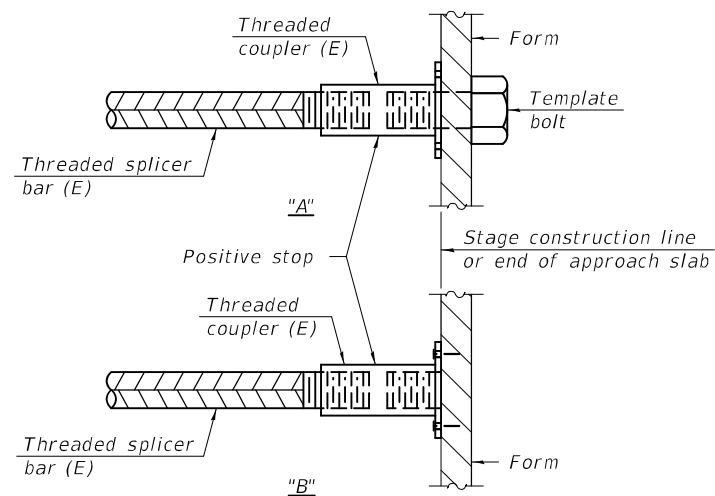

**INSTALLATION AND SETTING METHODS**

"A" : Set bar splicer assembly by means of a template bolt.

"B" : Set bar splicer assembly by nailing to wood forms or cementing to steel forms.

(E) : Indicates epoxy coating.

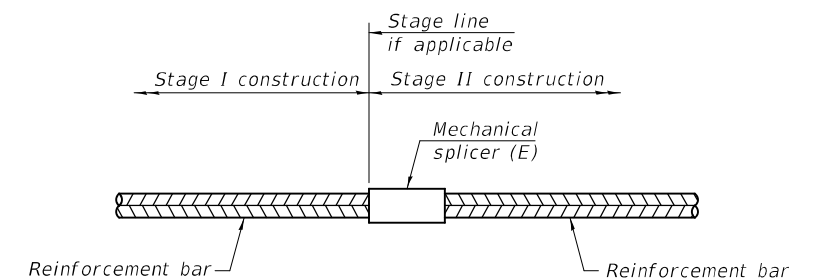

**STANDARD MECHANICAL SPLICER**

Location	Bar size	No. assemblies required

**Notes:**

Splicer bars shall be deformed with threaded ends and have a minimum 60 ksi yield strength.

All reinforcement shall be lapped and tied to the splicer bars.

Bar splicer assemblies shall be epoxy coated according to the requirements for reinforcement bars. See Section 508 of the Standard Specifications.

See approved list of bar splicer assemblies and mechanical splicers for alternatives.

BSD-1

1-1-2020

DESIGNED - ATH  
CHECKED - CCC  
DRAWN - Venkat Ramana Reddy  
CHECKED - ATH CCC

PASSED

*Jaime F. Joffe*  
ENGINEER OF BRIDGES AND STRUCTURES

DATE - February 2, 2023

REVISED -  
REVISED -

STATE OF ILLINOIS  
DEPARTMENT OF TRANSPORTATION

BAR SPLICER ASSEMBLY AND MECHANICAL SPLICER DETAILS  
SN 086-0042 (EB) & 0043 (WB)

SHEET NO. 11 OF 15 SHEETS

F.A.I. RTE.	SECTION	COUNTY	TOTAL SHEETS	SHEET NO.
72	(86-8) BDR1,BJR1,BRR1,BP	SCOTT	45	45
ILLINOIS			FED. AID PROJECT	

CONTRACT NO. 72136

STATE OF ILLINOIS  
DEPARTMENT OF TRANSPORTATION

DATE	SECTION	COUNTY	TOTAL SHEETS	SHEET NO.	SHEET NO.
8-20-88	86-88-1	SCOTT	176	53	10 SHEETS
DESIGNED BY: J. F. SCHNEIDER					
CHECKED BY: ALEX SINDWA					
DRAWN BY: J. SCHNEIDER					
CHECKED BY: ALEX SINDWA					

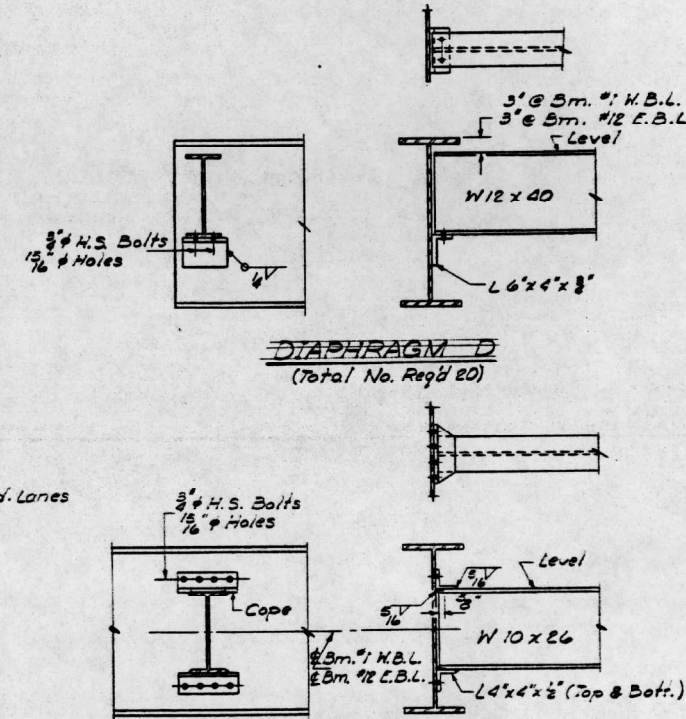
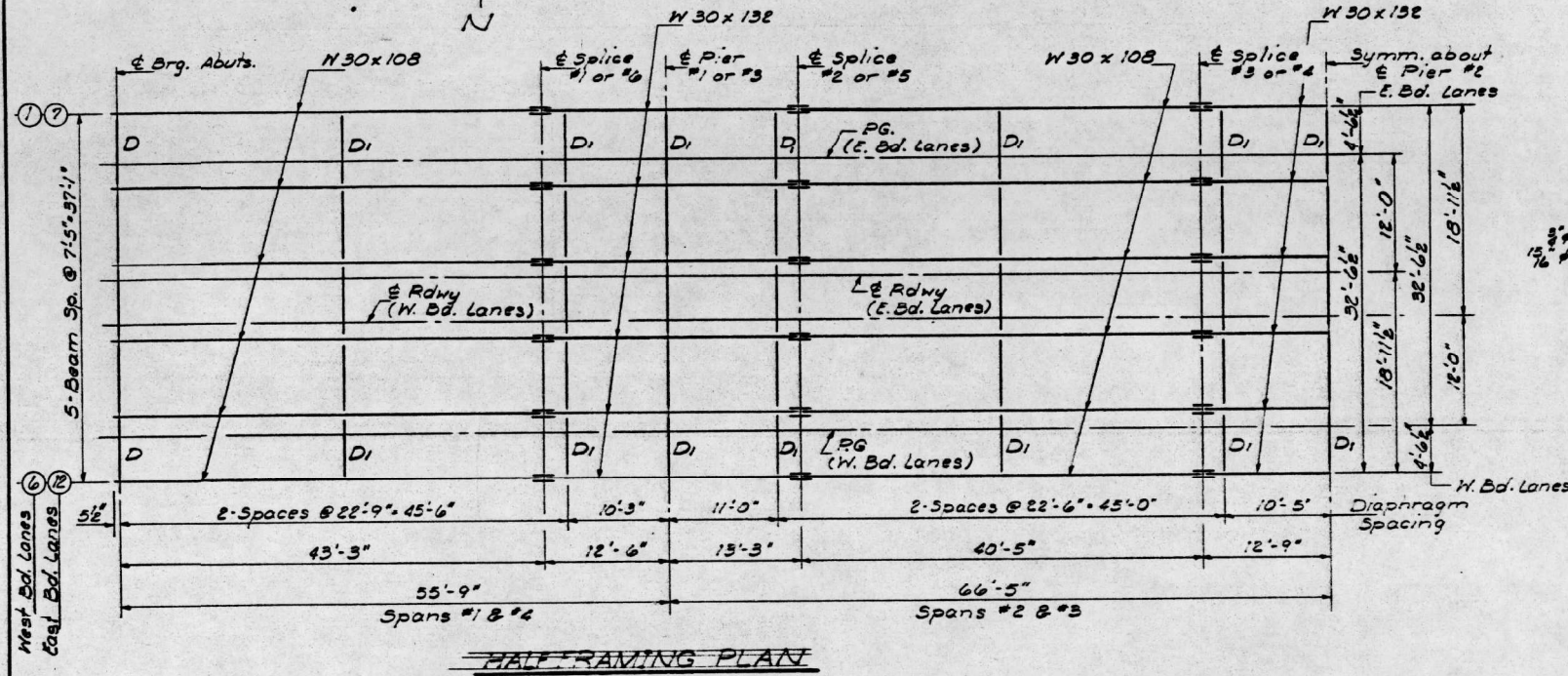

NOTES:  
Hardened washers shall be required over all 1/2" holes.

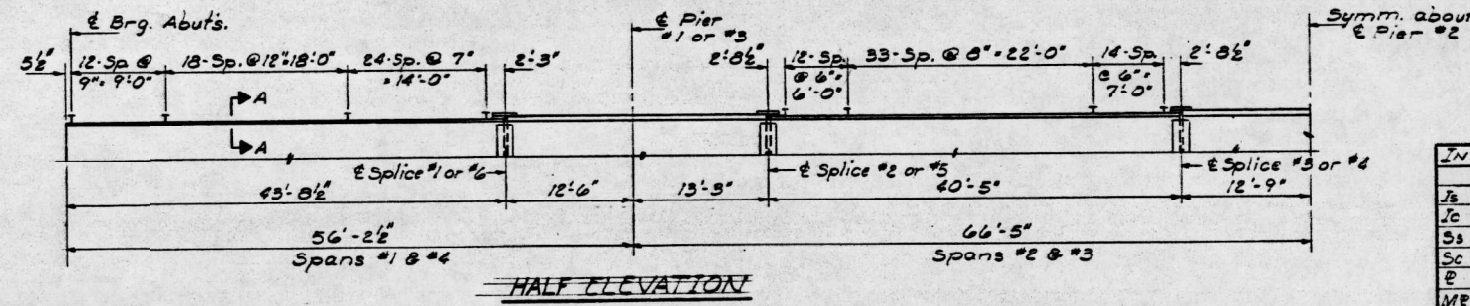

INTERIOR W BEAM MOMENT TABLE

	4 Sp/184 Piers 183.5 Sp/283 Piers 2		
$I_b$ (in <sup>4</sup> )	4470	5770	4470
$I_c$ (in <sup>4</sup> )	12125		12125
$S_b$ (in <sup>3</sup> )	299	380	299
$S_c$ (in <sup>3</sup> )	440		440
$Q$ (k/ft)	.831	.833	.836
$M_p$ (k)	228.2	437.1	176.7
$f_s$ comp (ksi)	9.2	13.8	7.1
$S_e$ (k/ft)	.320	.320	.320
$M_s$ (k)	103.8	128.5	99.3
$M_t$ (k)	905.2	551.2	937.1
$M_{imp}$ (k)	250.5	148.2	244.6
TOTAL (k)	1259.5	827.9	1281.0
$f_s$ comp (ksi)	34.4	26.1	34.9
$f_s$ TOTAL (ksi)	43.6	39.9	42.0
VR (k)	54.7		46.9

TOP OF FLANGE ELEVATIONS\*

Span	Loc	Elev. 'A'	Elev. 'B'
#1	#2	446.07	446.09
#2	#1	446.25	446.25
#3	#1	446.35	446.37
#4	#9	446.41	446.43
#5	#8	446.50	446.52
#6	#7	446.16	446.18

Elev. 'A' @ E Brg West & East Abutments.  
Elev. 'B' @ E Splices thru #6 & Piers #1, #2 & #3.  
Elevations at splice are for top of W 30 x 132 flange.  
\* For fabrication only.

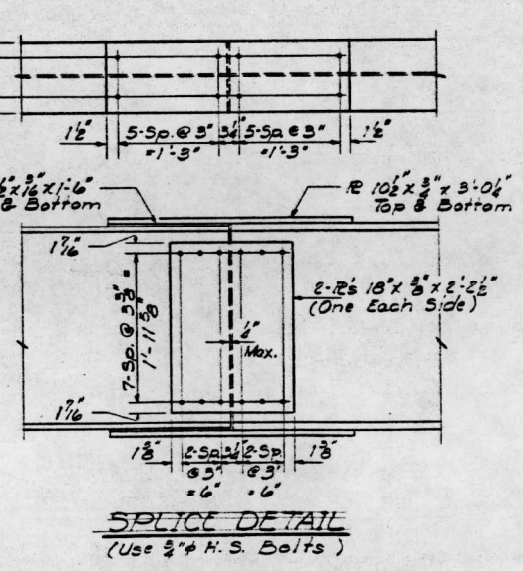
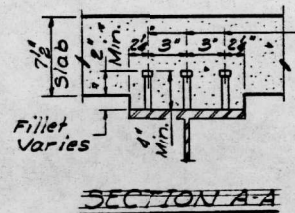

INTERIOR W.B.M. REACTION TABLE

	Abuts	Piers 183	Pier 2
$R_e$ (k)	24.5	78.6	76.2
$R_l$ (k)	59.2	48.0	49.1
$R_{imp}$ (k)	10.8	12.9	12.8
TOTAL (k)	74.5	139.5	138.1

$I_b$  and  $S_b$  are the moment of inertia and section modulus of the steel section used in computing  $f_s$  TOTAL.  
 $I_c$  and  $S_c$  are the moment of inertia and section modulus of the composite section used in computing  $f_s$  TOTAL.  
VR is the maximum  $\pm$  impact shear range in span used to determine shear connector spacing.  
The Load Factor 1.3 [2 + 3/8 (E + 2)] is used for computing moments and stresses.  
Values given in Reaction tables are based upon service load.

FOR INFORMATION ONLY

W 30 & E 30 LANES  
STRUCTURAL STEEL  
F.A. RT. 408 SEC. 86-88-1  
SCOTT COUNTY  
STA. 45+38

DESIGNED Adh. Shenouda  
CHECKED ALEX SINDWA  
DRAWN J. SCHNEIDER  
CHECKED Adh. Shenouda

EXAMINED [Signature]  
PASSED [Signature]  
APPROVED [Signature]

JUNE 3 1980

Revised 3-31-86 ALC

STATE OF ILLINOIS  
DEPARTMENT OF TRANSPORTATION

ROUTE NO.	SECTION	COUNTY	TOTAL SHEETS	SHEET NO.	SHEET NO. 10
408	86-B-1	Scott	176	54	16 SHEETS
DESIGNED BY			DATE		

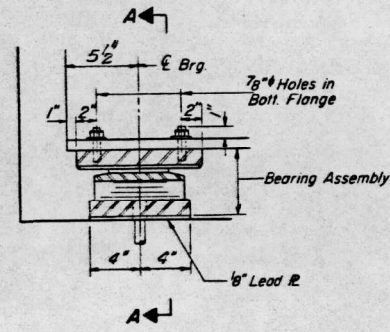

SECTION AT ABUTS.

TYPE II TFE ELASTOMERIC EXP. BRG.

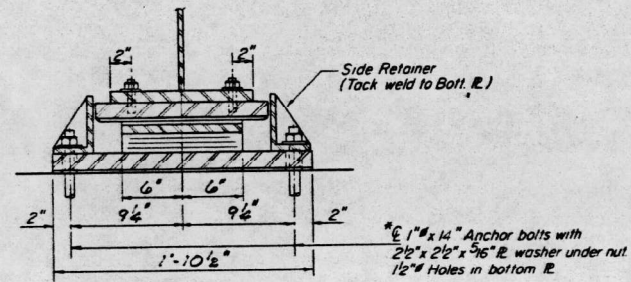

SECTION A-A

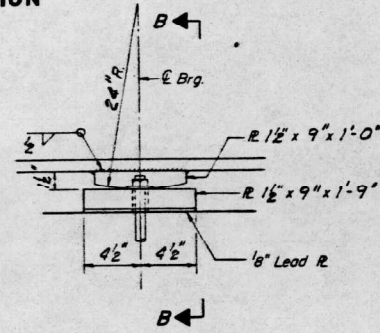

ELEVATION AT PIERS  
#1, #2 & #3

FIXED BEARING

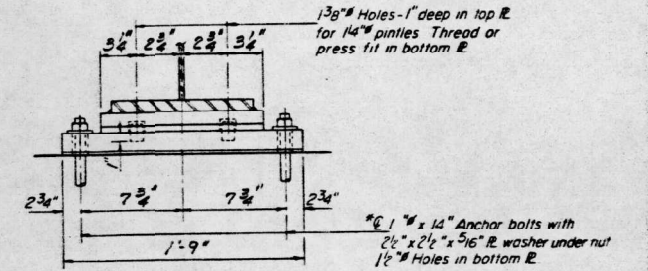

SECTION B-B

\*Note:  
Anchor bolts of fixed bearings  
may be built into the masonry.  
See sheet #16 of 16 for anchor  
bolt installation.

\*Note:  
Unless otherwise specified,  
all structural steel shapes  
and plates shall conform  
to AASHTO M-222 material  
requirements.

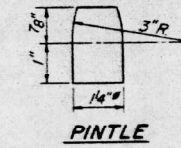

PINTLE

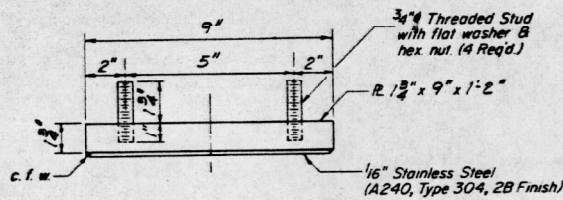

TOP BEARING ASSEMBLY

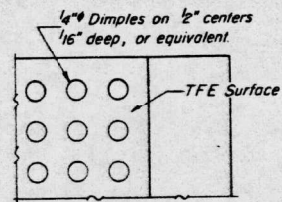

PLAN-TFE SURFACE

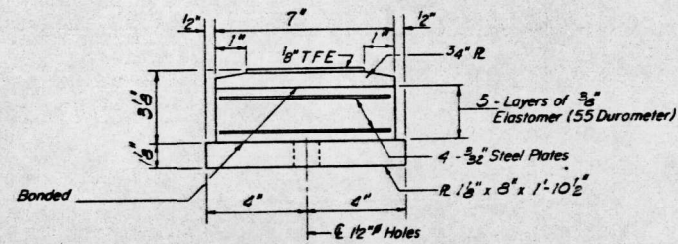

BOTTOM BEARING ASSEMBLY

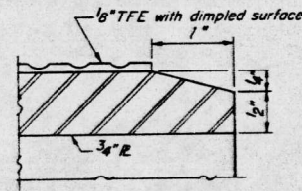

SECTION THRU TFE

Note: The 1/8" TFE sheet shall be bonded directly to the top steel plate with a two-component, medium viscosity epoxy resin, conforming to the requirements of the Federal Specification M/M-A-134, Type I. The bond agent shall be applied on the full area of the contact surfaces.

Bonding of 1/8" TFE sheet during vulcanizing process will be permitted provided the process and method of adjusting assembly height is approved by the Engineer.

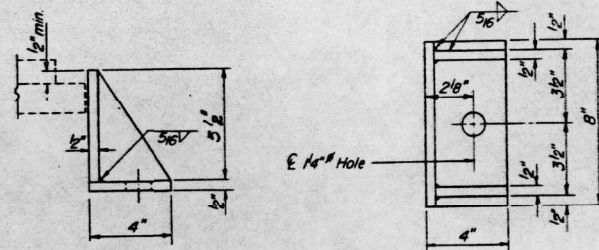

SIDE RETAINER

Equivalent rolled angle with stiffeners will be allowed in lieu of welded plates. (4B Required)

DESIGNED ALEX SINDYLA  
CHECKED Adli Sheenola  
DRAWN J. SCHNELLER  
CHECKED ALEX SINDYLA

EXAMINED JUN 5 3 1980  
PASSED  
APPROVED  
DIRECTOR OF HIGHWAYS

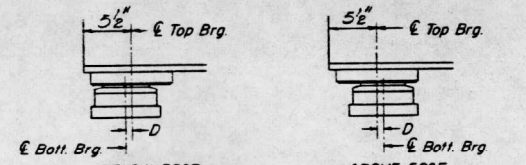

BELOW 50°F (Move bolt brg. away from fixed brg.)  
ABOVE 50°F (Move bolt brg. toward fixed brg.)

SETTING ANCHOR BOLTS AT EXP. BRG.

D = 1/8" per each 100' of expansion for every 15° temp. change from the normal temp. of 50°F

FOR  
INFORMATION  
ONLY

BEARING DETAILS  
FA RT 408 SEC. 86-BB-1  
SCOTT COUNTY  
STA. 45+38

I-2-E2 4-1-79

Revised JTB/ALC

DESIGNED - ATH  
CHECKED - CCC  
DRAWN - Venkat Ramana Reddy  
CHECKED - ATH CCC

PASSED

JOYCE F. [Signature]  
ENGINEER OF BRIDGES AND STRUCTURES

DATE - February 2, 2023

REVISED -  
REVISED -

STATE OF ILLINOIS  
DEPARTMENT OF TRANSPORTATION

EXISTING PLAN SHEET - FOR INFORMATION ONLY  
SN 086-0042 (EB) & 0043 (WB)

SHEET NO. 14 OF 15 SHEETS

F.A.I. RTE.	SECTION	COUNTY	TOTAL SHEETS	SHEET NO.
72	(86-8) BDR1,BJR1,BRR1,BP	SCOTT	45	45B
CONTRACT NO. 72136				
ILLINOIS		FED. AID PROJECT		

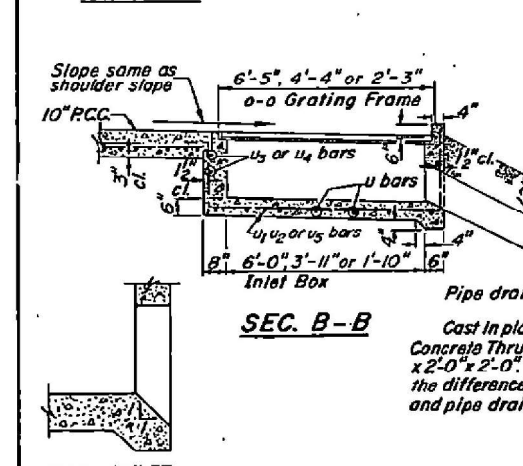
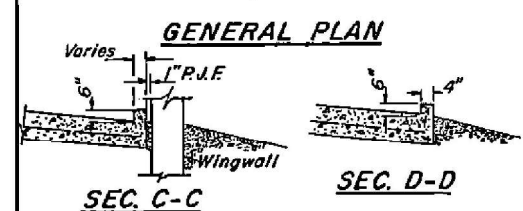
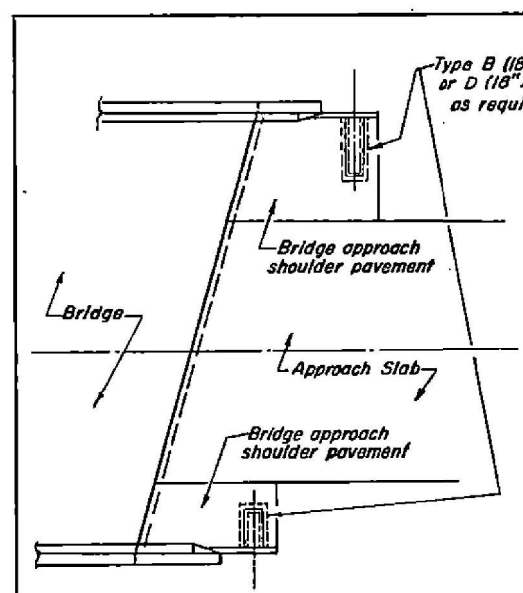

**BOX OUTLET WHEN PRECAST**

**GENERAL NOTES**

When Inlet Box or Boxes are not required, surface of the shoulder pavement shall be finished to provide a smooth transition from back of the abutment to normal approach roadway shoulder.

See plans for location of bridge approach shoulder pavement. Use Type C Inlet Box for 5' and 6' shoulder widths, use Type D Inlet Box for 7' and wider shoulder widths, use Type B Inlet Box for shoulders less than 5' wide.

For placement of approach shoulder pavement on existing construction substitute expansion anchor ties for tie bars. For non-rigid approaches, shoulder pavement will be as shown except omit tie bars in approach pavement.

The material for 12" Pipe Drains shall be either corrugated steel, aluminum alloy or polyethylene (RE.) pipe with UV protection.

Corrugated steel and aluminum alloy pipe shall have 2' coupling bands. All pipe connections shall be water tight.

The P.C. Concrete used in the shoulder slab shall meet the requirements of Section 40B of the Standard Specifications.

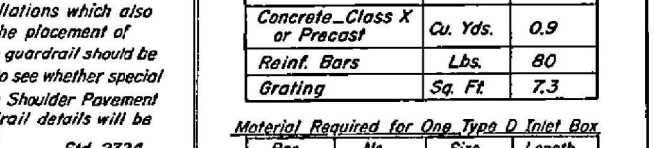
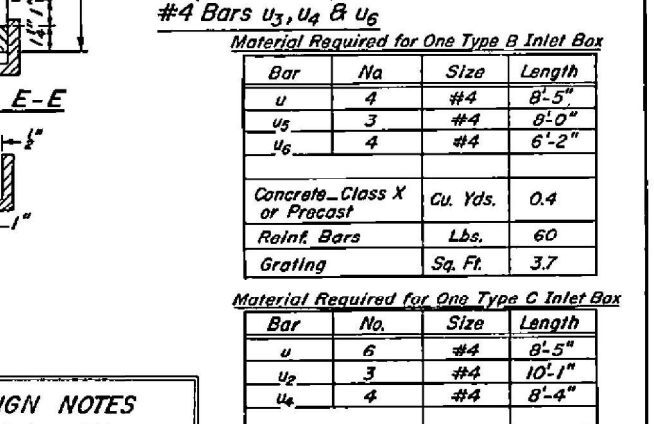
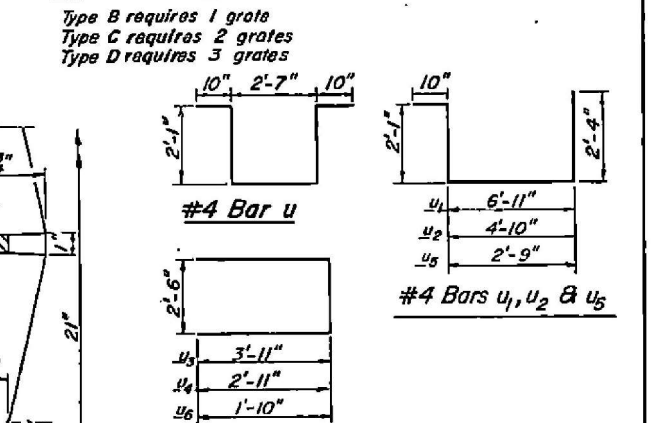
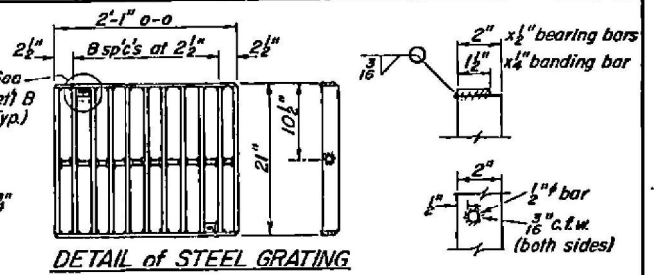
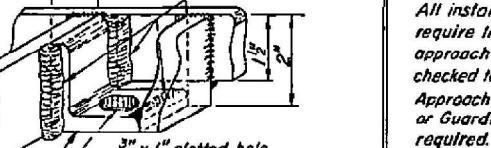
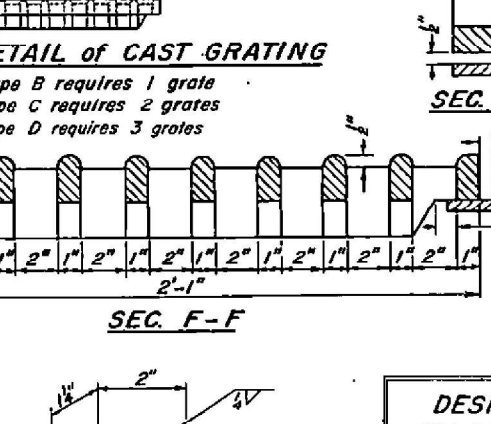
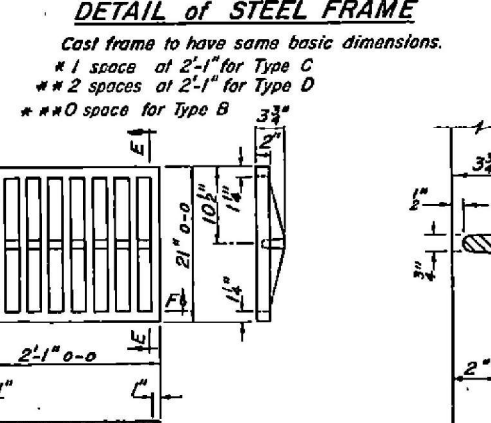
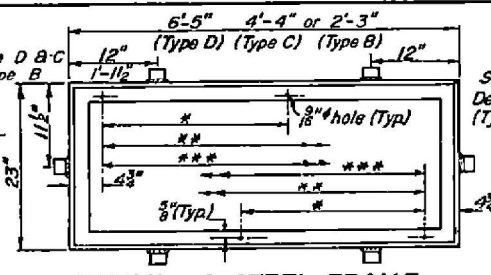
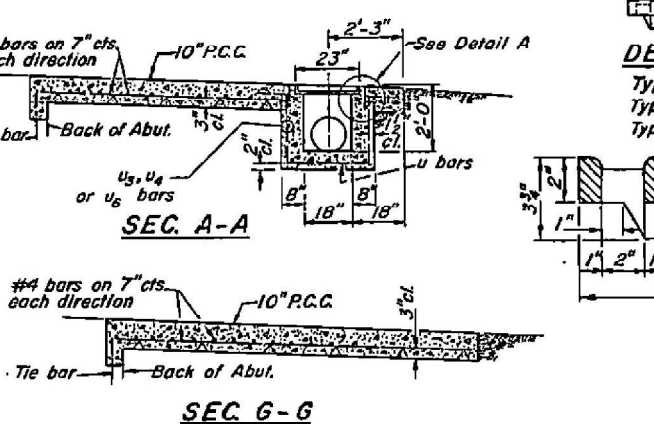
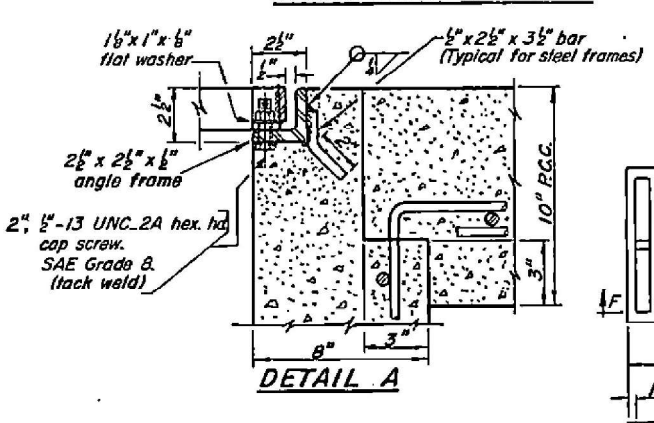
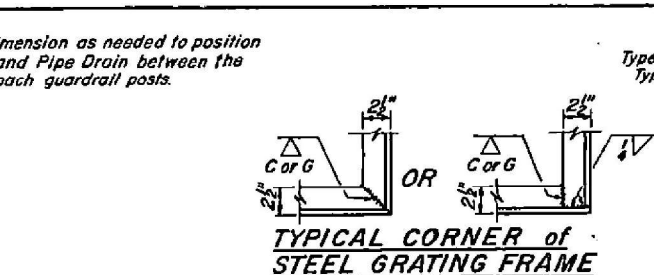
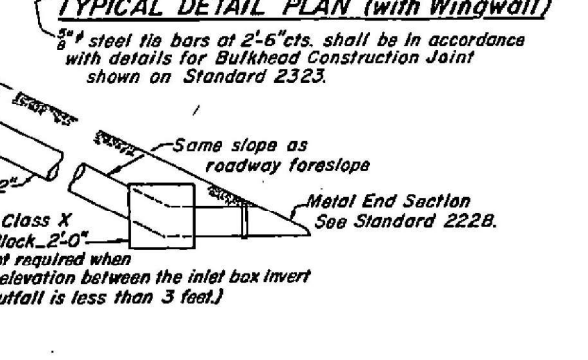
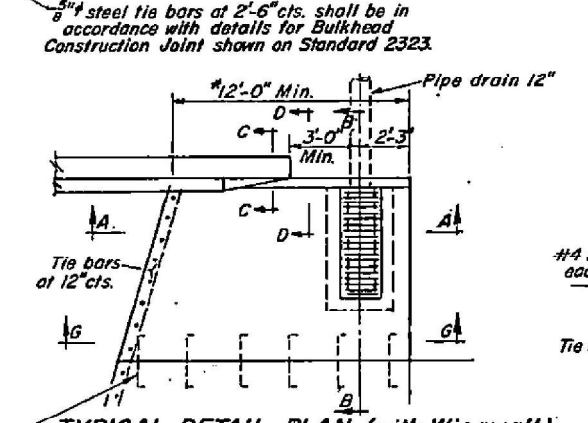
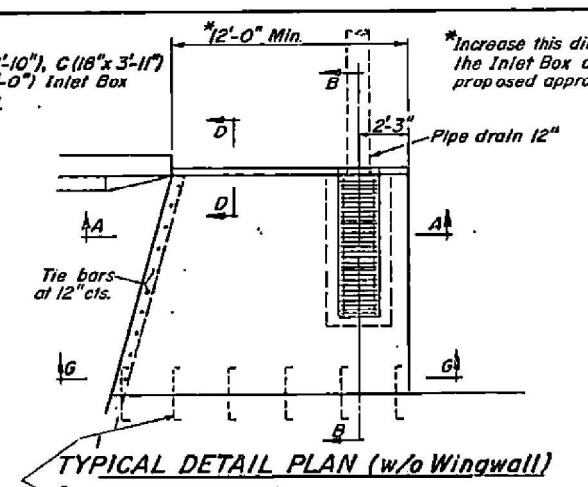

**DESIGN NOTES**

All installations which also require the placement of approach guardrail should be checked to see whether special Approach Shoulder Pavement or Guardrail details will be required. Sid. 2324

Design note will not appear in the contract plans.

**Material Required for One Type B Inlet Box**

Bar	No.	Size	Length
u	4	#4	8'-5"
u <sub>5</sub>	3	#4	8'-0"
u <sub>6</sub>	4	#4	6'-2"
Concrete - Class X or Precast		Cu. Yds.	0.4
Reinf. Bars		Lbs.	60
Grating		Sq. Ft.	3.7

**Material Required for One Type C Inlet Box**

Bar	No.	Size	Length
u	6	#4	8'-5"
u <sub>2</sub>	3	#4	10'-1"
u <sub>4</sub>	4	#4	8'-4"
Concrete - Class X or Precast		Cu. Yds.	0.9
Reinf. Bars		Lbs.	80
Grating		Sq. Ft.	7.3

**Material Required for One Type D Inlet Box**

Bar	No.	Size	Length
u	8	#4	8'-5"
u <sub>1</sub>	3	#4	12'-2"
u <sub>3</sub>	4	#4	10'-4"
Concrete - Class X or Precast		Cu. Yds.	1.2
Reinf. Bars		Lbs.	100
Grating		Sq. Ft.	11.0

**FOR INFORMATION ONLY**

The lengths of #4 bars used in the approach shoulder pavement shall be as required to accommodate the length, width and skew of the slab.

Class X concrete or precast concrete shall be used for the inlet. Precast concrete shall be in accordance with Sections 505.01 thru 505.05 of the Standard Specifications except that the concrete strength shall be 4000 p.s.i. after 28 days.

All exposed edges of the inlet, except the upper perimeter, shall be beveled 3/4".

Shop drawings will not be required for precast Inlet Boxes.

A 3" deep CA-12 bedding conforming to Article 704.01, D Quality or better shall be provided under full length and width of precast units, and all voids around the pipe drain entrance, both inside and outside, shall be sealed with mortar.

The grating shall seat firmly in the frame and steel grates shall be secured to the frame with a locking device as shown. Cast grates will not require the locking device.

Steel grating and frames shall conform to Article 710.04 of the Standard Specifications and shall be galvanized to AASHTO Specification M III after fabrication.

Cast grating and frames shall conform to Article 710.17 of the Standard Specifications. Cast grating and frames shall not be galvanized.

Pipe drains shall be installed, measured and paid for in accordance with Section 607 of the Standard Specifications, except sand bedding will not be required.

Metal End Sections shall be installed, measured and paid for in accordance with Section 511 of the Standard Specifications.

Bridge approach shoulder pavement will be measured in place and paid for in square yards as R.C. CONCRETE BRIDGE APPROACH SHOULDER PAVEMENT which shall include the cost of subgrade preparation, expansion anchor ties, reinforcement and joint fillers. In computing the area for payment, a deduction will be made for the area displaced by the inlet. (1.2 Sq. Yds. Type C; 1.7 Sq. Yds. Type D, 0.6 Sq. Yds. Type B)

The contract unit price "Each" for TYPE (B, C or D) INLET BOX STANDARD 2324, in place, shall include the frame and grating, class X or precast concrete, reinforcement bars, excavation, bedding when required, and compacted backfill.

The contract unit price "Each" for CONCRETE THRUST BLOCKS, in place, shall include excavation and compacted backfilling.

**BRIDGE APPROACH SHOULDER PAVEMENT**

**STANDARD 2324 - 6**  
(Full Size)

Illinois Department of Transportation

PASSED July 18, 1984

Engineer of Bridge and Traffic Structures

APPROVED July 18, 1984

Engineer of Design