

- O A INPUT CABLE
- O B CONNECTIONS
- O C CONNECTIONS
- O A OUTPUT CABLE
- O B CONNECTIONS
- O C CONNECTIONS

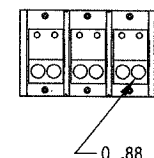
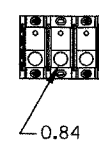
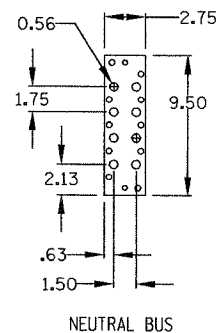
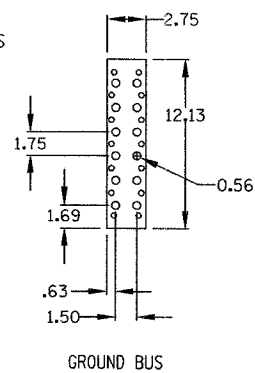
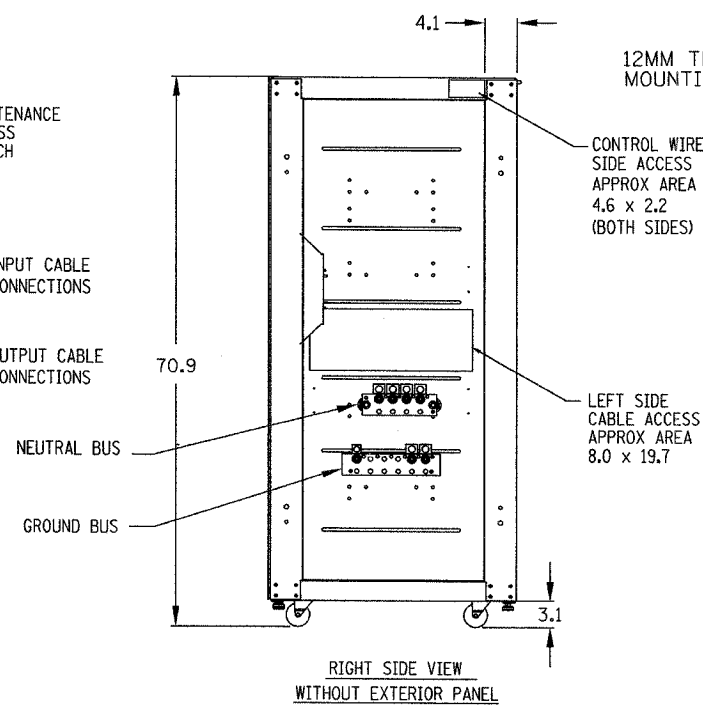

NOTES:

- ALL DIMENSIONS ARE IN INCHES.
- MIN CLEARANCE 36 FRONT, 12 TOP FOR AIR EXHAUST.
- KEEP CABINET WITHIN 15 DEGREES OF VERTICAL WHILE HANDLING.
- TOP AND BOTTOM CABLE ENTRY AVAILABLE THROUGH REMOVABLE ACCESS PLATES. REMOVE, PUNCH TO SUIT CONDUIT SIZE, AND REPLACE.
- CONTROL WIRING AND POWER WIRING MUST BE RUN IN SEPARATE CONDUIT. OUTPUT CABLES MUST BE RUN IN A SEPARATE CONDUIT FROM INPUT CABLES.
- ALUMINUM AND COPPER CLAD ALUMINUM CABLES ARE NOT RECOMMENDED.
- ALL WIRING IS TO BE IN ACCORDANCE WITH NATIONAL AND LOCAL ELECTRICAL CODES.
- INTER CABINET WIRING BETWEEN THE UPS AND THE MB CABINET IS SUPPLIED BY LIEBERT, INSTALLATION BY OTHERS.
- MAINTENANCE BYPASS CABINET IS NOT A STAND ALONE UNIT. IT IS BOLTED TO THE RIGHT SIDE OF THE UPS.
- COLOR - IBM OFF WHITE.
- UNIT BOTTOM IS STRUCTURALLY ADEQUATE FOR FORKLIFT HANDLING.
- THREADED MOUNTING HOLES USED FOR SEISMIC ANCHORING OR FLOOR STAND. NOTE, IF FLOOR STAND IS USED THE WEIGHT OF THE UNIT MUST BE SUPPORTED UNDER ALL CASTERS.
- EACH MOUNTING LOCATION IS SUPPORTED BY (2) 10 GA. (.135") GALVANIZED STEEL. THE THREADED 12MM INSERT IS APPROX. 3/4" DEEP. MOUNTING BOLTS MUST BE THREADED INTO UNIT MOUNTING HOLES FROM UNDERNEATH UNIT BASE.
- INCLUDES SIDE PANEL. REFER TO DETAIL A FOR DIMENSION TO FRAME WITH SIDE PANEL REMOVED. SIDE PANELS ARE REMOVED BETWEEN ADJACENT UNITS WHICH ARE BOLTED TOGETHER.

DT-12H

| REVISIONS | |
|-----------|------|
| NAME | DATE |
| | |
| | |
| | |
| | |
| | |
| | |
| | |
| | |

ILLINOIS DEPARTMENT OF TRANSPORTATION
F.A.I. 94/90 (DAN RYAN EXPRESSWAY)
31st STREET to I-57
TERMINAL DETAILS
25" MAINTENANCE BYPASS CABINET
CONFIGURATION "N" SINGLE INPUT
(NPOWER)

SCALE: AS SHOWN
DATE: October 29, 2004

DRAWN BY: SST
CHECKED BY: CS