

STATE OF ILLINOIS  
DEPARTMENT OF TRANSPORTATION

CONTRACT 62829

F.A.P. RTE. NO.	SECTION	COUNTY	TOTAL SHEETS	SHEET NO.
305	2004-088B	COOK	145	70
FED. ROAD DIST. NO. 1	BID NO.	FED. AID PROJECT		

SHEET NO. SA-17  
OF SHEETS SA-30

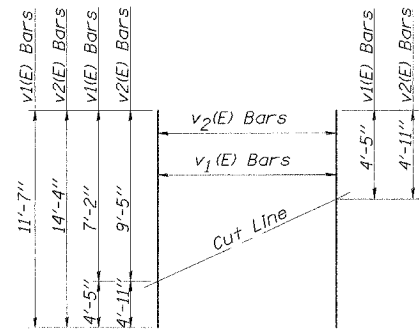

FIELD CUTTING  
DIAGRAM

Order  $v_1(E)$  &  $v_2(E)$  Bars full length. Cut as shown and use remainder of Bars in opposite face.

U(E) BAR SIZES	Bar	a
$u_2(E)$	2'-6"	
$u_3(E)$	3'-0"	
$u_4(E)$	3'-2"	
$u_5(E)$	3'-8"	

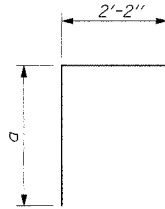

BARS  $u_2(E)$ ,  $u_3(E)$ ,  $u_4(E)$ ,  $u_5(E)$

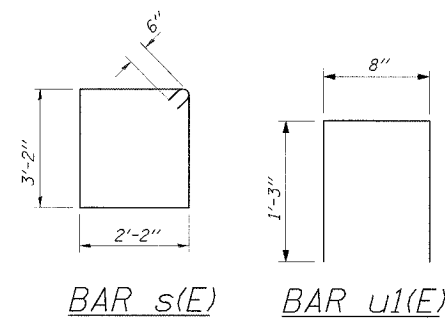
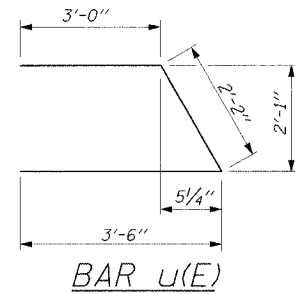

DESIGNED	AJN
CHECKED	JAP
DRAWN	ABW
CHECKED	EL

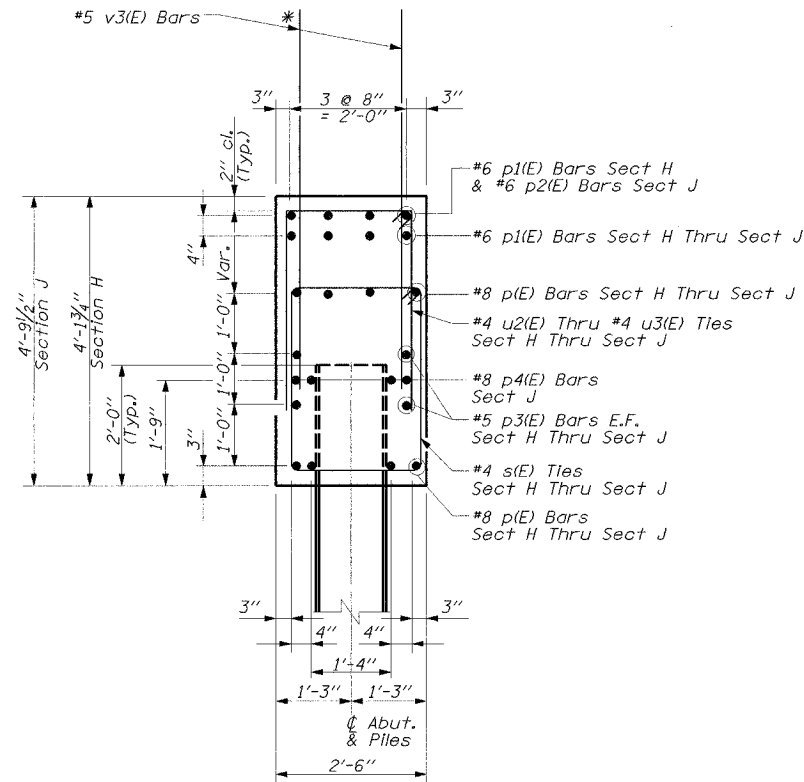
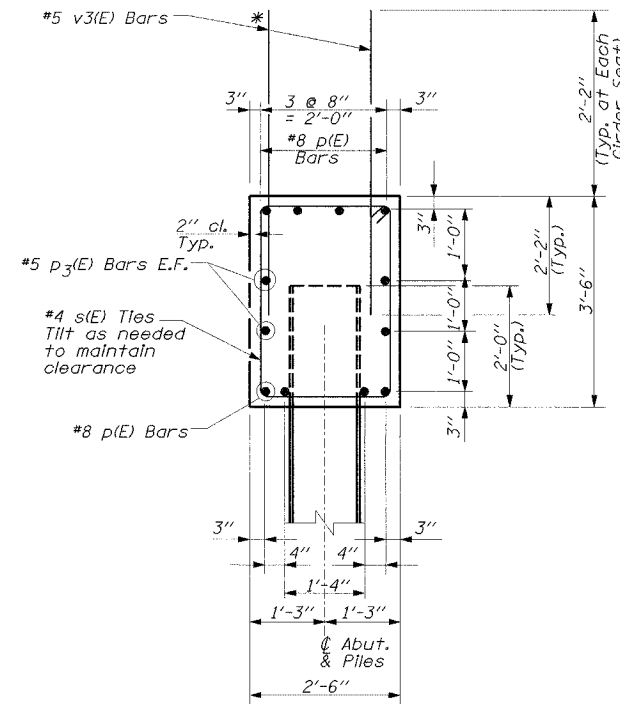

NOTE:

\* In cases where a beam is in the way, respace  $v_3(E)$  bars as needed.

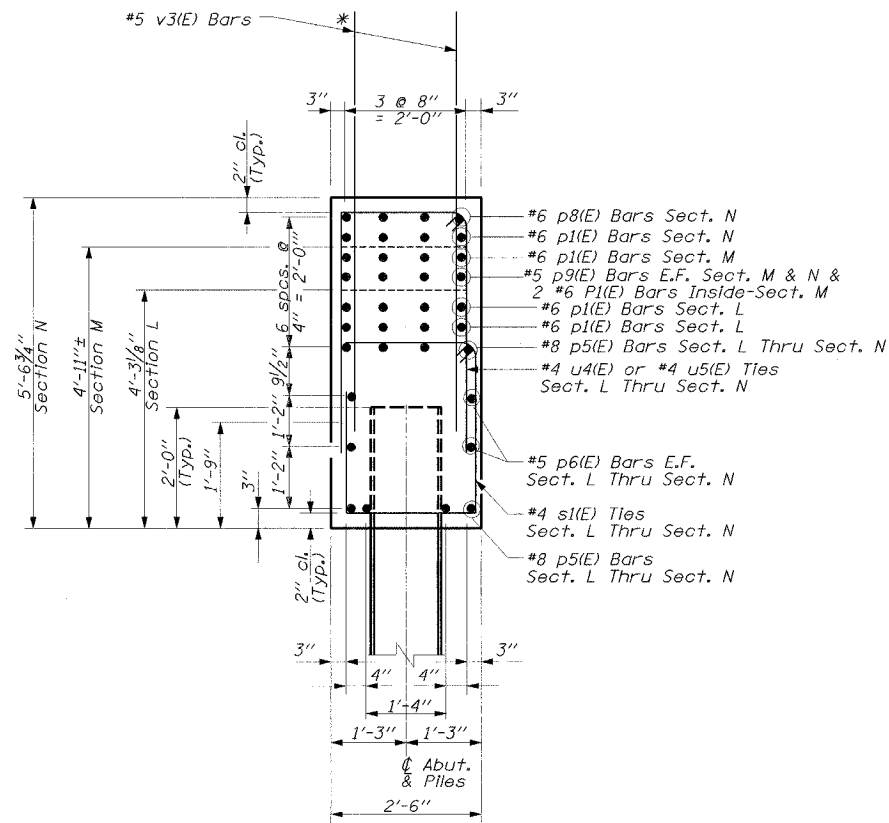
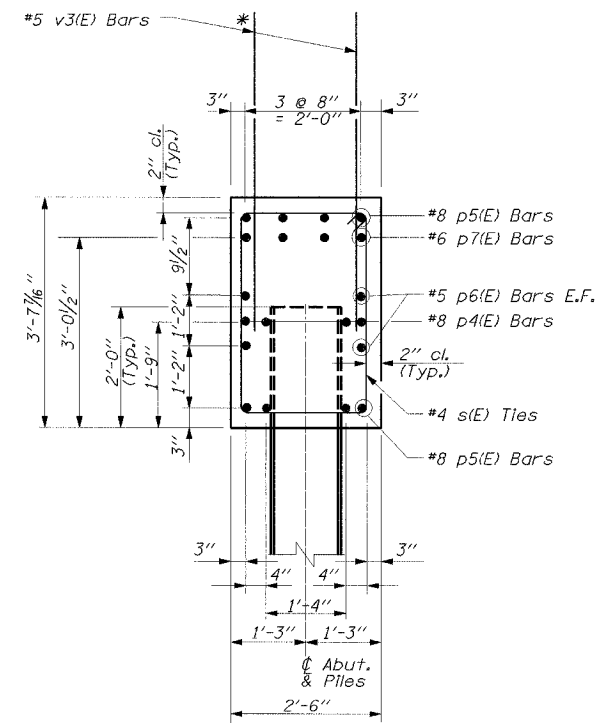

NOTATION:

F.F. - Front Face  
R.F. - Rear Face  
E.F. - Each Face  
T - Top  
B - Bottom

EAST ABUTMENT DETAILS  
WILLOW ROAD OVER  
MILWAUKEE AVENUE  
(IL RTE. 21/U.S. 45)  
F.A.P. RTE. 305  
SECTION 2004-088B  
COOK COUNTY  
STA. 391+71.02 @ WILLOW RD.  
STR. NO. 016-2786

EDWARDS AND KELCEY

12/28/2004 12:33:30 AM

F:\00009\04\04\04\Advance Contract\AdvStruct\Draw\Milw-Avnt\W-1.dwg