

FAU RTE.	SECTION	COUNTY	TOTAL SHEETS	SHEET NO.
0196	37RS-3	LAKE	12	4
STA.		TO STA.		
FED. ROAD DIST. NO.		ILLINOIS	FED. AID PROJECT	

CONTRACT NO.: 62860

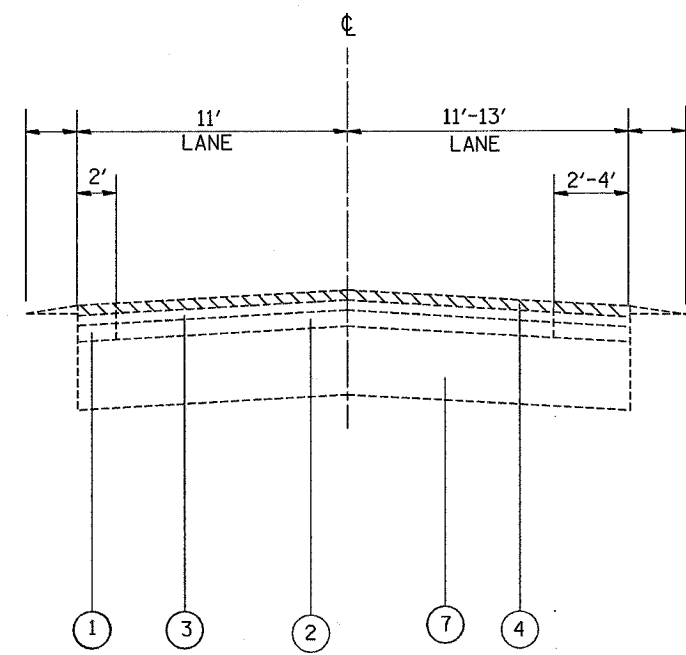

EXISTING TYPICAL CROSS SECTION
 STA. 0+38 TO STA. 10+16
 (LOOKING NORTHEAST)

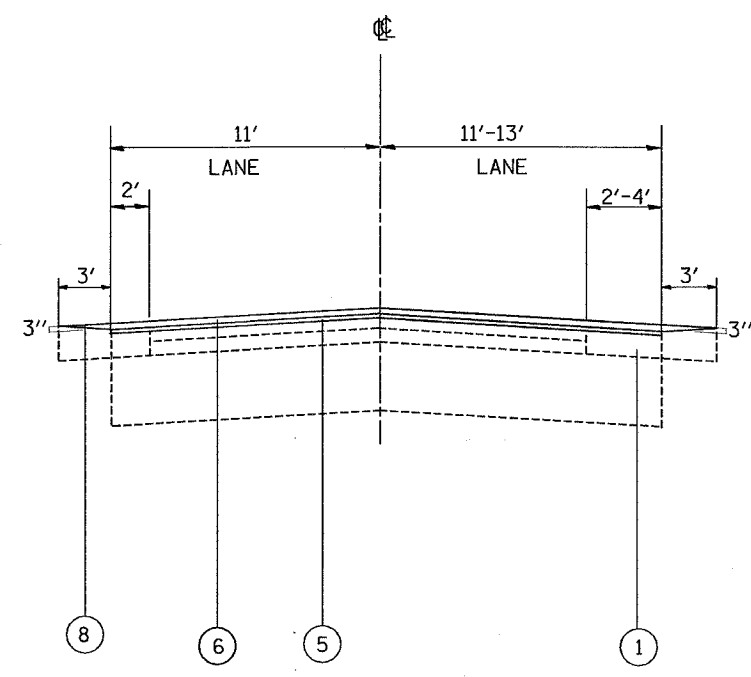

PROPOSED TYPICAL CROSS SECTION
 STA. 0+38 TO STA. 10+16
 (LOOKING NORTHEAST)

LEGEND

- ① EXISTING BITUMINOUS CONCRETE, 11.25" - 18.50", (2'-4' WIDENING STRIPS)
- ② EXISTING P.C.C. PAVEMENT, 6" - 7.75"
- ③ EXISTING BITUMINOUS CONCRETE, VARIES 5.25" - 5.50"
- ④ PROPOSED BITUMINOUS CONCRETE SURFACE REMOVAL, 2 1/2"
- ⑤ PROPOSED POLYMERIZED LEVELING BINDER (MACHINE METHOD), SUPERPAVE, IL-4.75, N50, 3/4"
- ⑥ PROPOSED POLYMERIZED BITUMINOUS CONCRETE SURFACE CSE, SUPERPAVE, MIX "F", N90, 1 3/4"
- ⑦ EXISTING SUB-BASE GRANULAR MATERIAL
- ⑧ PROPOSED AGGREGATE SHOULDERS, TYPE B

REVISIONS	
NAME	DATE

ILLINOIS DEPARTMENT OF TRANSPORTATION
 IVANHOE RD.
 TYPICAL SECTION
 SCALE: VERT. _____
 DATE _____
 DRAWN BY: CADD
 CHECKED BY: _____