

STATE OF ILLINOIS
DEPARTMENT OF TRANSPORTATION

ROUTE NO.	SECTION	COUNTY	TOTAL SHEETS	SHEET NO.	SHEET NO. 26 31 SHEETS
F.A.P. 312	71BR	RANDOLPH	73	50	
FED. ROAD DIST. NO. 7		ILLINOIS	FED. AID PROJECT-		

Contract No. 76125

PIER 2
BILL OF MATERIAL

Bar	No.	Size	Length	Shape
hg(E)	4	#4	24'-4"	—
hg(E)	4	#4	30'-10"	—
hd(E)	60	#4	10'-8"	—
hd(E)	42	#4	10'-2"	—
hd(E)	120	#4	2'-0"	—
pg(E)	4	#10	24'-4"	—
pd(E)	4	#10	30'-10"	—
pd(E)	4	#10	25'-11"	—
pd(E)	4	#10	32'-5"	—
pd(E)	6	#10	12'-6"	—
sg(E)	58	#4	12'-11"	□
sg(E)	16	#4	7'-8"	□
sg(E)	16	#4	7'-2"	□
sg(E)	42	#4	4'-0"	□
** sp4(E)	4	#5	11'-2"	⋈
** sp6	4	#5	24'-8"	⋈
u2(E)	6	#6	9'-11"	⌒
v10(E)	44	#9	13'-6"	⌒
v12(E)	44	#9	11'-6"	—
v13(E)	66	#4	9'-9"	—
v14(E)	66	#4	7'-11"	—
v15	44	#9	24'-8"	—
Underwater Structure Excavation Protection Location 2	Each		1	
Drilled Shaft in Soil 42"	Foot		58.8	
Drilled Shaft in Rock 36"	Foot		41.0	
Concrete Structures	Cu. Yd.		53.9	
Reinforcement Bars, Epoxy Coated	Pound		9930	
Reinforcement Bars	Pound		6330	
Structure Excavation	Cu. Yd.		13.8	

Reinforcement Bars designated (E) shall be epoxy coated.
**Length is height of spiral.

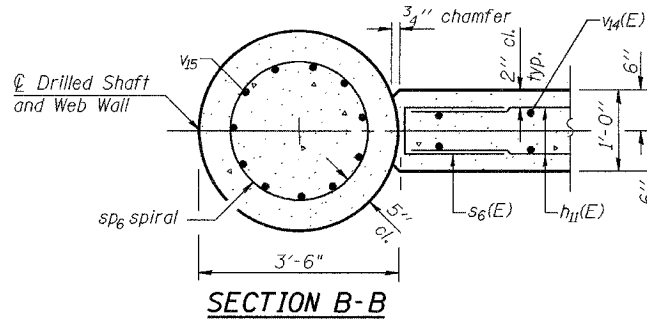
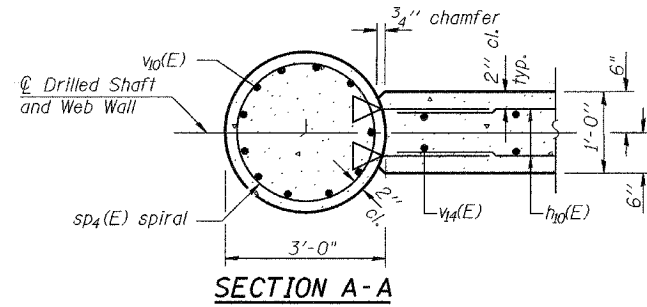

Construction Sequence for Web Wall:

1. Excavate between shafts to elevation of web wall base and set lower web wall forms through water to bear on the circular edge of drilled shafts. Secure in place with fill, struts or tie forms together as required.
2. Place the lower web wall reinforcement cage into the forms using spacers to maintain proper clearances.
3. If the forms can be sealed against the shafts and streambed to allow dewatering, the reinforcement and the concrete placement may be completed in the dry. Alternatively, the rebar cage can be lowered into position through water and the concrete discharged at the base of the excavation through a tremie pipe or pump hose, displacing water, sediment, and tainted concrete out the top of the forms.
4. Construct Columns.
5. Construct upper web walls.

* If the prevailing water surface elevation during construction is consistently different than estimated on the plans, the contractor may propose an adjustment to the top of the drilled shaft elevation as part of their installation procedure. The top of all drilled shafts within a substructure unit shall be constructed to the same elevation and extend above the prevailing water surface. The quantities and reinforcement detailing are based on the top of shaft and the estimated elevations shown and may change based on the actual elevations encountered at each shaft and the final top of shaft elevation.

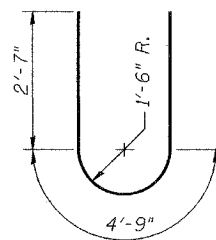

BAR u2(E)

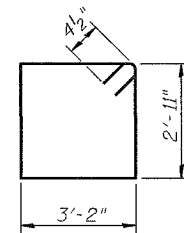

BAR s3(E)

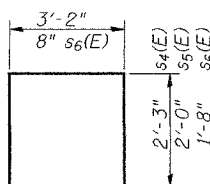

BARS s4(E), s5(E) & s6(E)

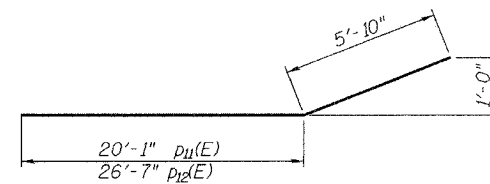

BARS p11(E) & p12(E)

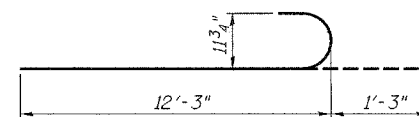

BAR v10(E)

DESIGNED	T.L. Kurtenbach
CHECKED	J.E. Kramer
DRAWN	A.M. Seiber
CHECKED	JEK/TLK

January 26, 2005
EXAMINED *Thomas J. Demagalaki*
PASSED *Ralph E. Anderson*
ENGINEER OF BRIDGES AND STRUCTURES

PIER 2
F.A.P. RT. 312 - SEC. 71BR
RANDOLPH COUNTY
STATION 1128+90
STRUCTURE NO. 079-0048