

T.R.	SECTION	COUNTY	TOTAL SHEETS	SHEET NO.
235	93-02109-00-BR	CHRISTIAN	18	18
FED. ROAD DIST. NO. 7		ILLINOIS	FED. AID PROJECT-	
SHEET 10 OF 10				

** 1" Joint shall be packed with a very dry mix of 2:1 sand and P.C. mortar. 1" Dimension may Vary plus or Minus to accommodate Tolerance in Beam Lengths.

*** Dowel Rods to be grouted after beams are in place and allowed to cure (Min. 24 hours) prior to grouting Shear Keys.

*** 3/4" ϕ x 1'-6" Dowel Rods in 1/4" ϕ holes drilled in Cap (2 Each Beam) Cost Incidental to Concrete Structures.

1 - 9" x 1/2" x 2'-1" (Interior Fabric Brg. Pad) or 1 - 9" x 1/2" x 1'-0 1/2" (Exterior Fabric Brg. Pad)

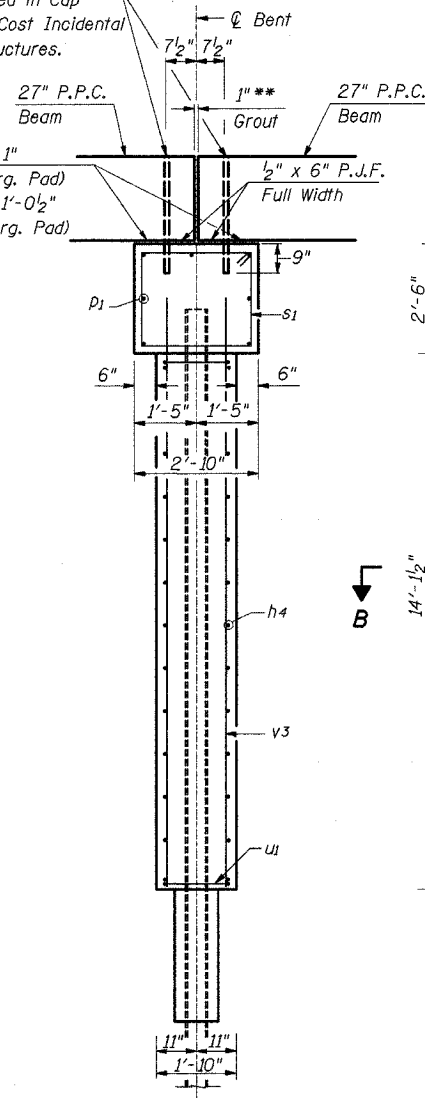

END VIEW

PILE DATA

Type	=	HP 10 x 42
Capacity	=	Drive to Refusal
Estimated Length	=	29'
Number Req'd.	=	6

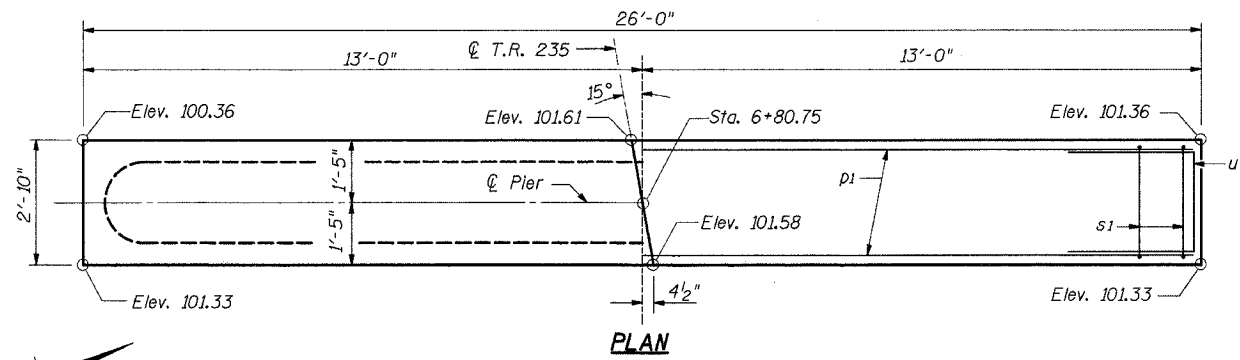

PLAN

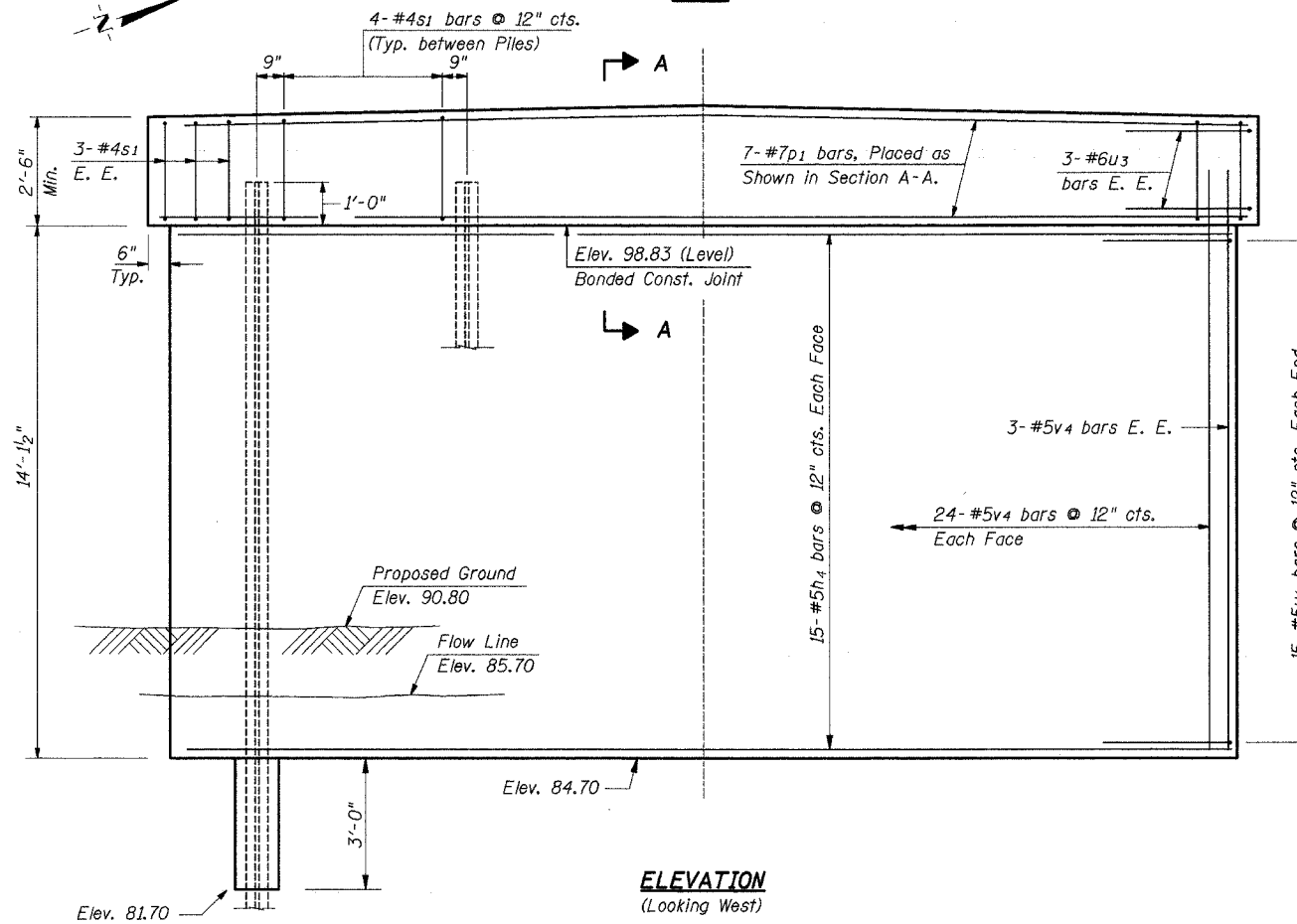

ELEVATION
(Looking West)

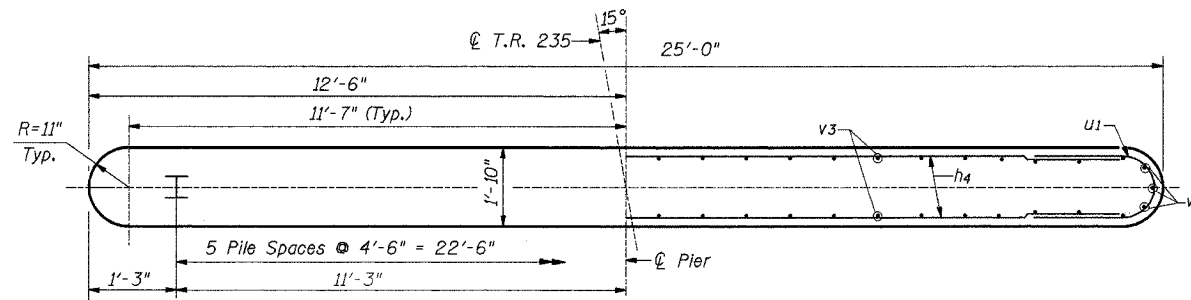

SECTION B-B

NOTE:
All Edges shall have Standard 3/4" Chamfer except as Noted.

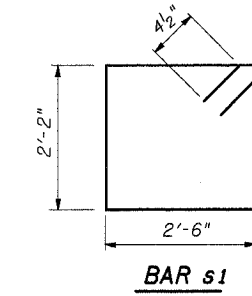

BAR s1

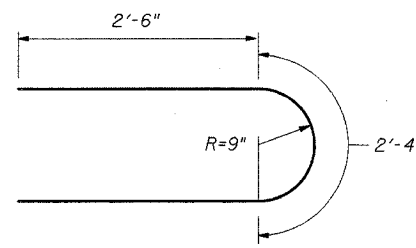

BAR u1

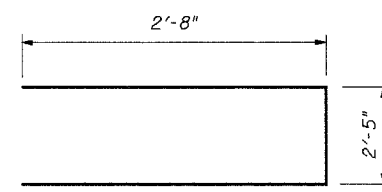

BAR u3

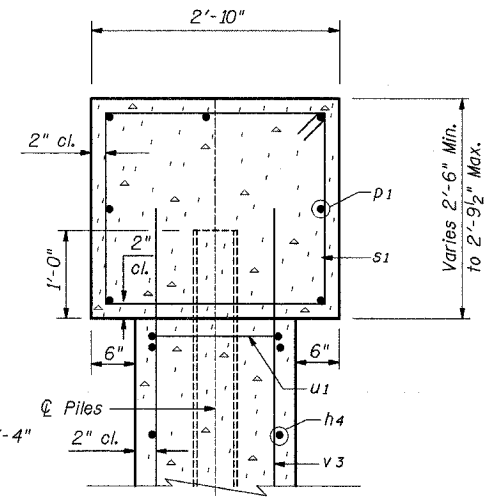

SECTION A-A

BILL OF MATERIAL

Bar	No.	Size	Length	Shape
h4	30	#5	22'-10"	—
p1	7	#7	25'-8"	—
s1	26	#4	10'-1"	□
u1	30	#5	7'-4"	⌒
u3	6	#6	7'-9"	⌒
v3	54	#5	15'-6"	—

ITEM	UNIT	QUANTITY
Reinforcement Bars	Pound	2430
Concrete Structures	Cu. Yd.	30.8
Furnishing Steel Piles, HP 10 x 42	Foot	174
Driving Steel Piles	Foot	174
Structure Excavation	Cu. Yd.	39
Concr. Encasement	Cu Yd.	1.6
Underwater Structure Excavation Protection, Location 2	Ea.	1

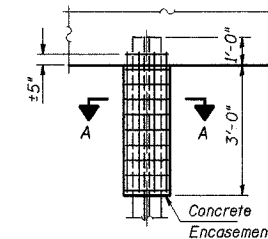

PILE ENCASEMENT DETAIL

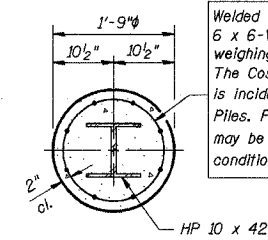

SECTION A-A

PILE ENCASEMENT DETAIL

PIER 3 DETAILS
T.R. 235 OVER BEAR CREEK
SECTION 93-02109-00-BR
CHRISTIAN COUNTY
STR. NO. 011-3400
STA. 6+24.42

ie INTERNATIONAL ENGINEERING CONSULTANTS, INC.
6420 SOUTH SIXTH STREET
SPRINGFIELD, ILLINOIS 62707
TEL. (217) 529-8027
FAX (217) 529-4543
IESPRINGFIELD@IE-CONSULTANTS.COM
WWW.IE-CONSULTANTS.COM

DESIGNED BY: G.B.M.	CHECKED BY: D.R.B.	DRAWN BY: THW	DATE: 5-03-04
------------------------	-----------------------	------------------	------------------