

ROUTE NO.	SECTION	COUNTY	TOTAL SHEETS	SHEET NO.	SHEET NO. 4
F.A.P. RTE. 774	107BY	EFFINGHAM	344	296	29 SHEETS
FED. ROAD DIST. NO. 7 ILLINOIS FED. AID PROJECT					
CONTRACT NO. 94827					

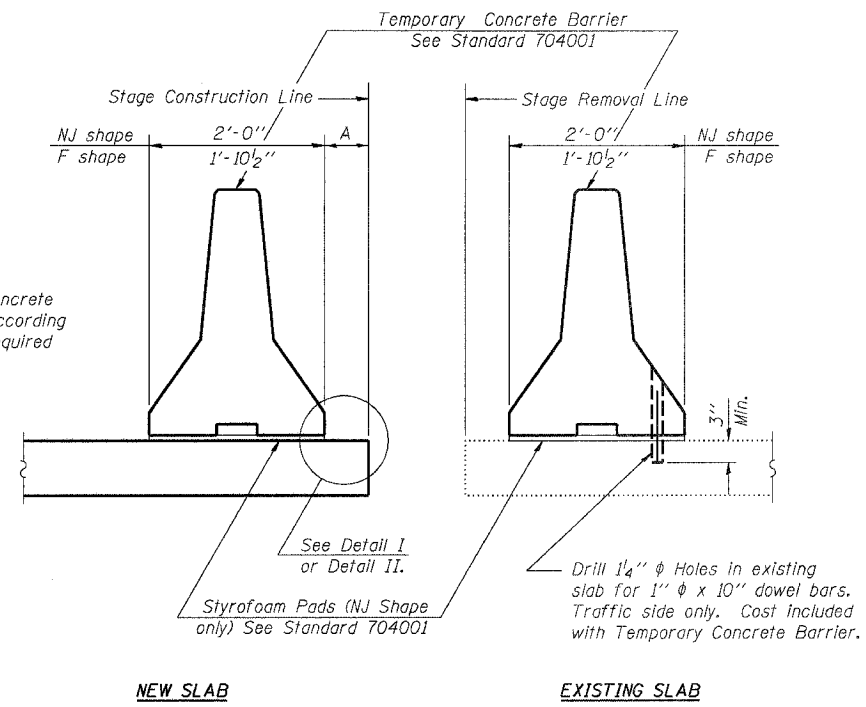

SECTIONS THRU SLAB

NOTES

- Detail I - With Bar Splicer or Couplers:
Connect one (1) 1"x7"x10" steel \bar{P} to the top layer of couplers with 2-5/8" ϕ bolts screwed to coupler at approximate \bar{C} of each barrier panel.
- Detail II - With Extended Reinforcement Bars:
Connect one (1) 1"x7"x10" steel \bar{P} to the concrete slab with 2-5/8" ϕ Expansion Anchors or cast in place inserts spaced between the top layer of reinforcement at approximate \bar{C} of each barrier panel.
- Cost of anchorage is included with Temporary Concrete Barrier.

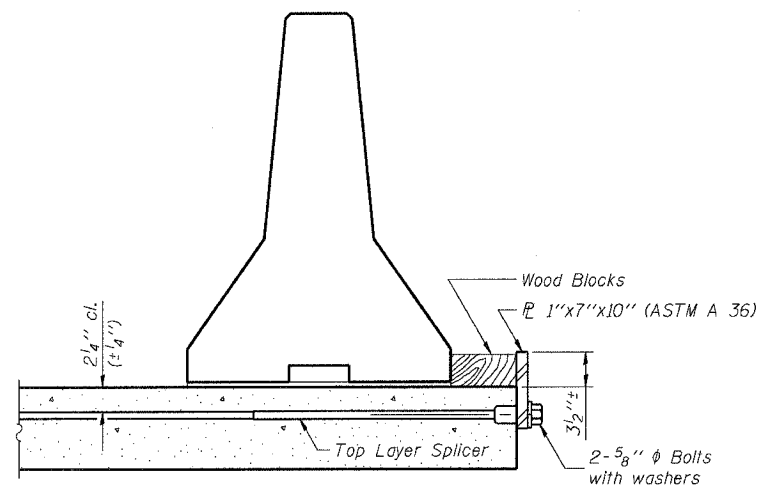

DETAIL I

The 1"x7"x10" Plate shall not be removed until Stage II Construction forms and reinforcement bars are in place.

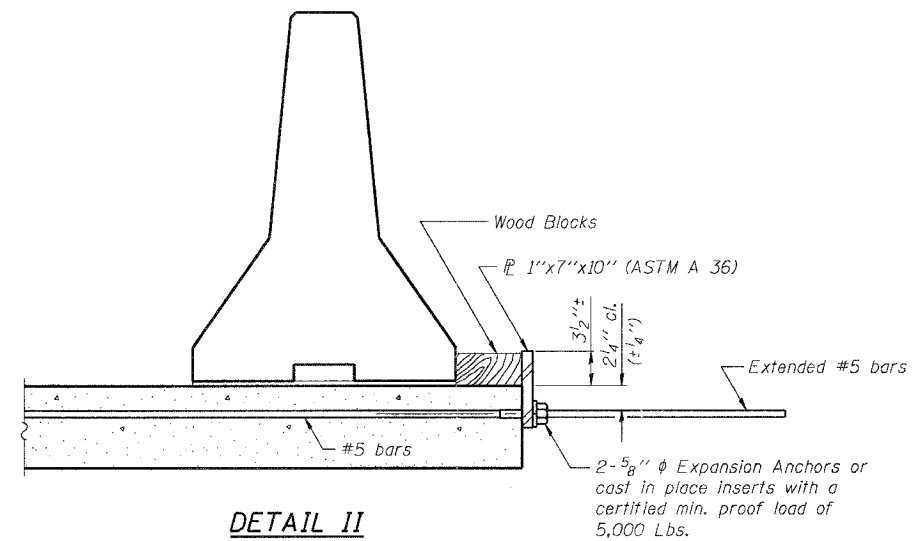

DETAIL II

The 1"x7"x10" Plate shall not be removed until Stage II Construction forms and all reinforcement bars are in place and the concrete is ready to be placed.

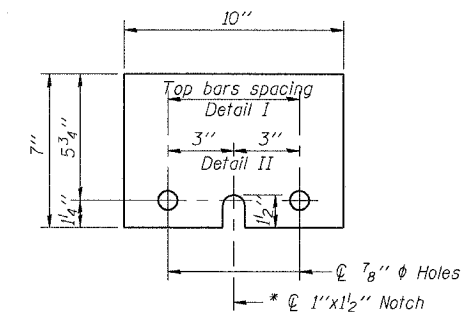

\bar{P} 1"x7"x10"

* Required only with Detail II

SHEET TITLE		PROJECT NO.	
TEMPORARY CONCRETE BARRIER FOR STAGED CONSTRUCTION		02017	
PROJECT	DATE	DRAWN BY	CHECKED BY
IL RTE. 32/33 OVER LITTLE WABASH RIVER F.A.P. RTE. 774 SECTION 107BY EFFINGHAM COUNTY STATION 1011+50.17 STRUCTURE NO. 025-0078		TFG	GJB/MCB
DRAWING NO.		4	
COOMBE-BLOXDORF P.C. Engineers / Land Surveyors Springfield, Illinois Design Firm License No. 184-002703		OF 29 SHTS	