

REVISIONS

| NUMBER | BY | DATE |
|--------|----|------|
|        |    |      |
|        |    |      |
|        |    |      |

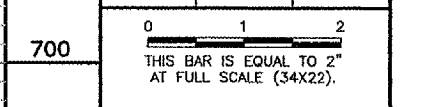

**AURORA MUNICIPAL AIRPORT  
 AURORA, ILLINOIS  
 CONSTRUCT NORTHEAST QUADRANT APRON,  
 CONNECTING TAXIWAY AND RUNWAY 27 STOPWAY  
 STORM SEWER PROFILES AND  
 DRAINAGE DETAILS**

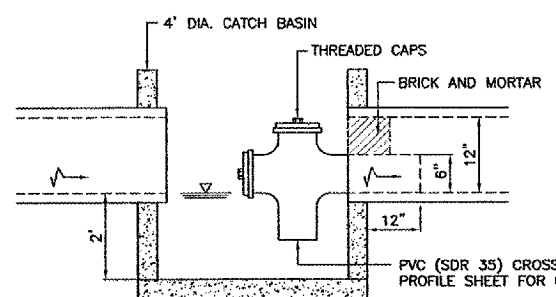

**RESTRICTOR CATCH BASIN**  
 NOT TO SCALE  
 FOR 100 YEAR EVENT, RESTRICTOR IS 6" OR LESS

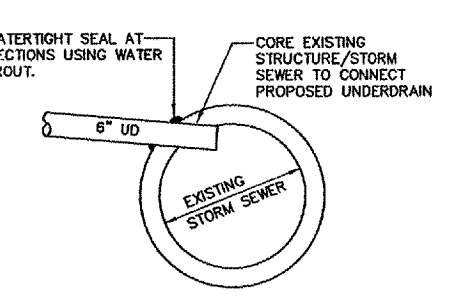
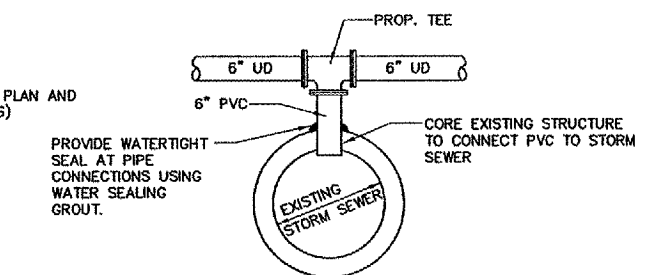

**UNDERDRAIN CONNECTION DETAILS**  
 NOT TO SCALE

| INSIDE DIAMETER OF STORM SEWER (INCHES) | MAXIMUM TRENCH WIDTH |
|---|----------------------|
| 6                                       | 3'-7"                |
| 8                                       | 3'-9"                |
| 12                                      | 4'-2"                |
| 15                                      | 4'-6"                |
| 18                                      | 4'-9"                |
| 21                                      | 5'-0"                |
| 24                                      | 5'-4"                |
| 27                                      | 5'-7"                |
| 30                                      | 5'-11"               |
| 36                                      | 6'-6"                |
| 42                                      | 7'-1"                |

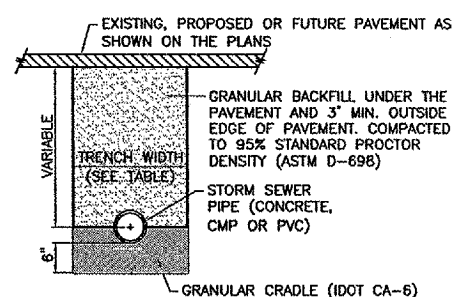

**ALL PAVED AREAS**

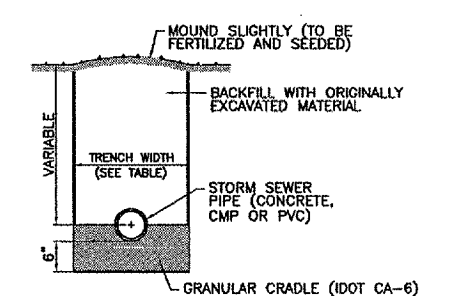

**NON-PAVED AREAS**

**TRENCH DETAILS - STORM SEWER**  
 NOT TO SCALE

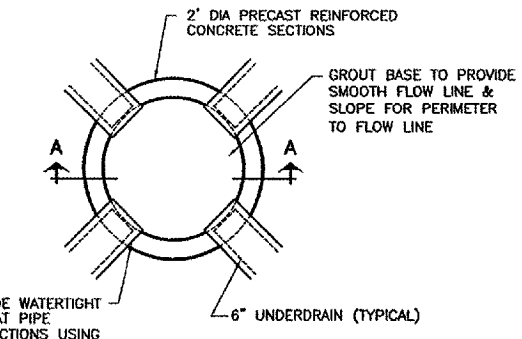

**PLAN VIEW**

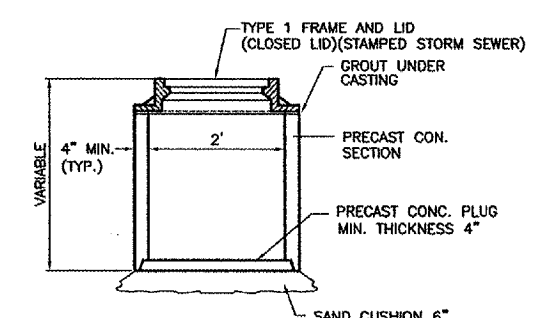

**SECTION A-A**

**UNDERDRAIN COLLECTION STRUCTURE DETAIL**  
 NOT TO SCALE

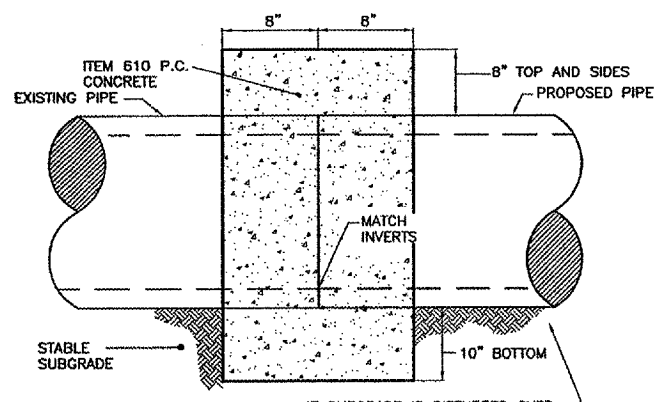

**CONCRETE COLLAR - STORM SEWER**  
 NOT TO SCALE

UNDERDRAIN CONNECTIONS AND FITTINGS, TEES AND ELBOWS USED FOR CONNECTIONS TO PROPOSED STRUCTURES / EXISTING STORM SEWERS, SHALL BE CONSIDERED INCIDENTAL TO THE PROPOSED UNDERDRAIN. SEE PLAN AND PROFILE NOTES.

© Copyright CMT, Inc.

**CMT**  
 CRAWFORD, MURPHY & TILLY, INC.  
 CONSULTING ENGINEERS  
 License No. 184-00019

DESIGN BY: MND  
 DRAWN BY: JRO  
 CHECKED BY: MJS  
 APPROVED BY: DKP  
 DATE: 01/26/05  
 JOB No: 04285-03  
 ILLINOIS PROJECT: ARR-3442  
 A.I.P. PROJECT: 3-17-0003-B30  
**FINAL SUBMITTAL**  
 SHEET 21 OF 39 SHEETS