

RESTORATION OF WORK AREA

RESTORATION OF THE TRAFFIC SIGNAL WORK AREA SHALL BE INCIDENTAL TO THE RELATED PAY ITEM SUCH AS FOUNDATION, CONDUIT, HANDHOLE, TRENCH AND BACKFILL, ETC., AND NO EXTRA COMPENSATION SHALL BE ALLOWED. ALL ROADWAY SURFACES SUCH AS SHOULDERS, MEDIANS, SIDEWALKS, PAVEMENT, ETC. SHALL BE REPLACED IN KIND. ALL DAMAGE TO MOWED LAWNS SHALL BE REPLACED WITH AN APPROVED SOD, AND ALL DAMAGE TO UNMOWED FIELDS SHALL BE SEEDED IN ACCORDANCE WITH STANDARD SPECIFICATIONS 252 AND 250 RESPECTIVELY.

NOTES FOR TEMPORARY TRAFFIC SIGNALS

- ① ALL CONTROL EQUIPMENT INCLUDING EMERGENCY PRE-EMPTION AND COMMUNICATION DEVICES FOR THE TEMPORARY TRAFFIC SIGNAL (S) SHALL BE FURNISHED BY THE CONTRACTOR.
- ② ONLY CONTROLLERS SUPPLIED BY ONE OF THE DISTRICT APPROVED CLOSED LOOP EQUIPMENT MANUFACTURERS WILL BE APPROVED FOR USE AT TEMPORARY SIGNAL LOCATIONS. ALL CONTROLLERS USED FOR TEMPORARY TRAFFIC SIGNALS SHALL BE FULLY ACTUATED NEMA MICROPROCESSOR BASED WITH RS232 DATA ENTRY PORTS COMPATIBLE WITH EXISTING MONITORING SOFTWARE APPROVED BY IDOT DISTRICT 1, INSTALLED IN A NEMA TS1 OR TS2 CABINET. ONLY ONE BRAND OF CONTROLLER WILL BE ACCEPTED FOR ANY ONE CONTRACT.
- ③ ALL TRAFFIC SIGNAL SECTIONS SHALL BE 12" (300mm). HEADS SHALL BE PLACED AS INDICATED ON THE TEMPORARY TRAFFIC SIGNAL PLAN OR AS DIRECTED BY THE ENGINEER. THE CONTRACTOR SHALL FURNISH ENOUGH CABLE SLACK TO RELOCATE HEADS TO ANY POSITION ON THE SPAN WIRE OR AT LOCATIONS ILLUSTRATED ON THE PLANS FOR CONSTRUCTION STAGING. THE TEMPORARY TRAFFIC SIGNAL SHALL REMAIN IN OPERATION DURING ALL SIGNAL HEAD RELOCATIONS. EACH TEMPORARY TRAFFIC SIGNAL HEAD SHALL HAVE ITS OWN CABLE FROM THE CONTROLLER CABINET TO THE SIGNAL HEAD. ALL SIGNAL HEADS SHALL BE L.E.D.
- ④ ALL EXISTING STREET NAME AND INTERSECTION REGULATORY SIGNS SHALL BE REMOVED FROM EXISTING POLES, RELOCATED AND SECURELY FASTENED TO THE SIGNAL SPAN WIRE OR WOOD POLE AS DIRECTED BY THE ENGINEER.
- ⑤ ANY TEMPORARY SIGNAL WITHIN AN EXISTING CLOSED LOOP TRAFFIC SIGNAL SYSTEM SHALL BE INTERCONNECTED TO THAT SYSTEM USING SIMILAR BRAND CONTROL EQUIPMENT.
- ⑥ THE TEMPORARY TRAFFIC SIGNAL SHALL HAVE THE SIGNAL HEAD DISPLAYS, SIGNAL HEAD PLACEMENTS AND CONTROLLER PHASING MATCH THE EXISTING TRAFFIC SIGNAL. AT THE TIME OF THE TURN ON, IF NO TRAFFIC STAGING IS IN PLACE OR WILL NOT BE STAGED ON THE DAY OF THE TURN ON.
- ⑦ CONTROLLER WITH STEEL BASE CABINET AND BATTERY BACK-UP CABINET SHALL BE MOUNTED ON A SERVICE ENTRANCE POLE.
- ⑧ UN-INTERRUPTABLE POWER SUPPLY (UPS) SHALL BE INCLUDED IN "TEMPORARY BRIDGE TRAFFIC SIGNAL INSTALLATION" PAY ITEM.
- ⑨ 10 WOOD POLES INSTALLED BY THE TRAFFIC CONTRACTOR (SEE TEMPORARY TRAFFIC SIGNAL PLANS FOR LOCATIONS).

TEMPORARY LIGHTING NOTES

- ① TEMPORARY LUMINAIRE, SODIUM VAPOR, 400 WATT, 240V, HORIZONTAL-MOUNT, PHOTO-CELL, TYPE II DISTRIBUTION.
- ② TEMPORARY LIGHTING TO BE REMOVED AS DIRECTED BY IDOT WHEN ROADWAY CONSTRUCTION IS COMPLETE.
- ③ ALL SYSTEMS ARE TO BE REQUIRED TO REMAIN OPERATIONAL DURING STAGED CONSTRUCTION.
- ④ GROUND EVERY THIRD POLE WITH TEMPORARY LUMINAIRE UNLESS NOTED OTHERWISE ON PLAN.
- ⑤ TEMPORARY POLES SHALL BE 60 FEET UNLESS OTHERWISE NOTED.

TEMPORARY TRAFFIC SIGNAL & LIGHTING LEGEND

- 400 W, 240V, MCII HPS, WITH PHOTO CELL 20' MA, 50' MH ON WOOD POLE CLASS 4
- 2-1/4#4, AERIAL CABLE WITH MESSENGER WIRE UNLESS OTHERWISE NOTED
- TEMPORARY LIGHTING UNIT NUMBER - ONE CIRCUIT A
-
-
-
-
-
-
-

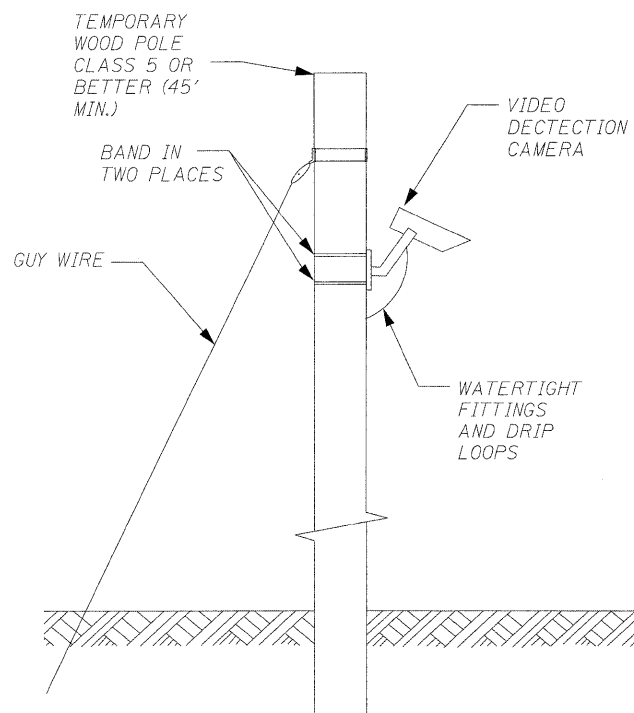

SCHEDULE OF QUANTITIES

ITEM	UNIT	TOTAL
AERIAL CABLE, 2-1/4 NO. 4 WITH MESSENGER WIRE	FOOT	1414
REMOVAL OF TEMPORARY LIGHTING UNITS	EACH	9
REMOVAL OF ELECTRIC SERVICE INSTALLATION	EACH	1
TEMPORARY ELECTRIC SERVICE CONNECTION	EACH	1
TEMPORARY ELECTRIC SERVICE INSTALLATION	EACH	1
REMOVAL OF TEMPORARY WOOD POLE, SALVAGE	EACH	3
TEMPORARY WOOD POLE, 60 FT. CLASS 4, 20 FT. MAST ARM	EACH	9
COMBINATION POLE MOUNTED ELECTRIC SERVICE BOX	EACH	1
TEMPORARY LUMINAIRE, SODIUM VAPOR, HORIZONTAL MOUNT, 400 W, TYPE II DISTRIBUTION	EACH	9
TEMPORARY WOOD POLE, 60 FOOT, CLASS 4	EACH	3
GROUND ROD, 5/8" DIA, X 10 FEET	EACH	5

NOTE: THIS WORK SHOWN IS FOR ESTIMATING PURPOSE ONLY. TEMPORARY LIGHTING WILL BE PAID UNDER "TEMPORARY LIGHTING FOR SINGLE LANE STAGING."

