

PLAN

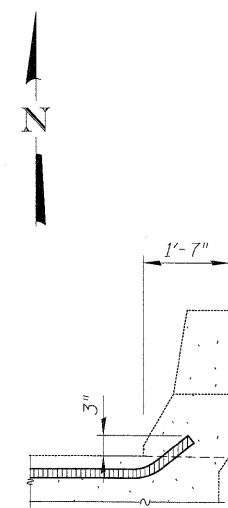

TYPICAL END OF SEAL TREATMENTS

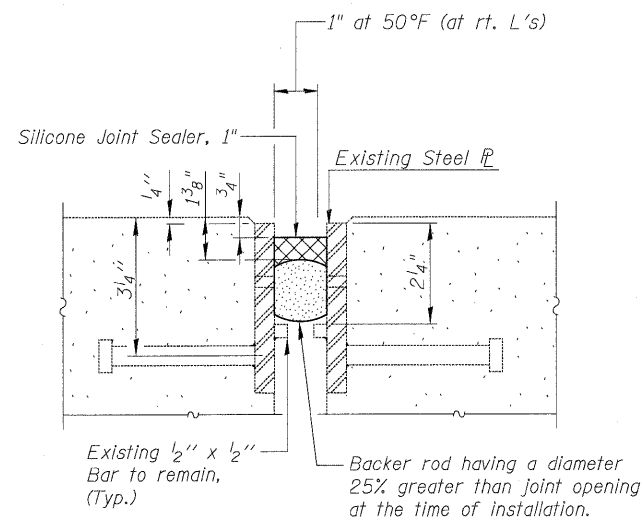

SECTION A-A

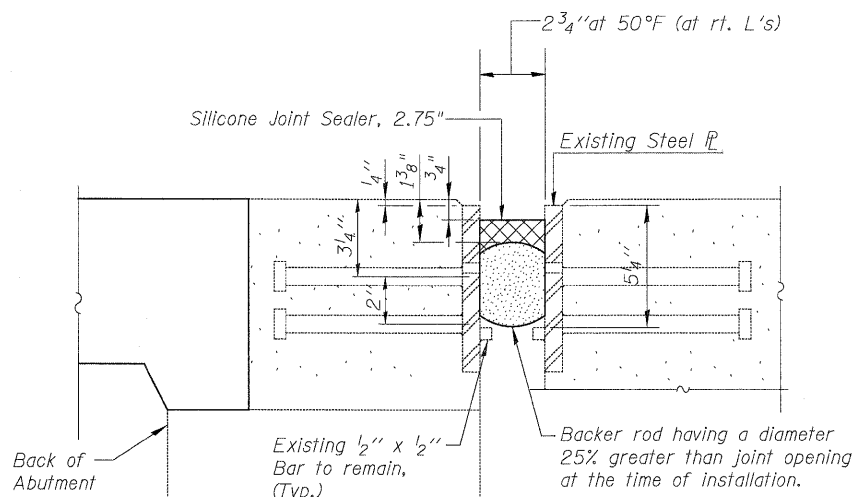

SECTION B-B

LEGEND:

Deck Slab Repair (Partial)

BILL OF MATERIAL

ITEM	UNIT	TOTAL
** Deck Slab Repair (Partial)	Sq.Yd.	20
Silicone Joint Sealer, 1"	Foot	106
Silicone Joint Sealer, 2.75"	Foot	106

** Work shall be performed in accordance with Special Provision Deck Slab Repair (Special)

NOTES

1. Remove the existing preformed joint seals and replace with silicone joint sealer as detailed in Sections A-A and B-B.
2. Areas of proposed deck repairs are estimated. Actual type, location and dimensions of deck repairs are to be determined by the Engineer during construction.
3. Removal of existing Silicone and Neoprene joint shall be included in the cost of Silicone Joint Sealer, 1" and 2.75".
4. Contractor may remove and replace guardrail components to facilitate joint replacement work. Cost included with Silicone Joint Sealer, 1" and 2.75".