

GENERAL NOTES

Fasteners shall be AASHTO M164 Type 1, mechanically galvanized bolts in painted areas and M164 Type 3 in unpainted areas. Bolts $\frac{7}{8}$ -in. ϕ , holes $\frac{15}{16}$ -in. ϕ , unless otherwise noted.

Calculated weight of Structural Steel = 63,370 lb.

All structural steel shall be AASHTO M 270 Grade 50W.

No field welding is permitted except as specified in the contract documents.

Reinforcement bars shall conform to the requirements of ASTM A 706 Gr 60. See Special Provisions.

Reinforcement bars designated (E) shall be epoxy coated.

Bearing seat surfaces shall be constructed or adjusted to their designated elevations within a tolerance of $\frac{1}{8}$ inch (0.01 ft.). Adjustment shall be made either by grinding the surface or by shimming the bearings.

Structural steel shall only be painted for a distance equal to the depth of embedment into the concrete cap plus 3 inches. Those areas shall be primed in the shop with a Department approved zinc rich primer. No field painting shall be required. All structural steel shall be cleaned as specified in the Special Provision for "Surface Preparation and Painting Requirements for Weathering Steel".

Layout of slope protection system may be varied in the field to suit ground conditions as directed by the Engineer.

The embankment configuration shown shall be the minimum that must be placed and compacted prior to construction of the abutments.

The Contractor shall drive test piles to 110% of the nominal required bearing specified in production locations at substructures specified or approved by the Engineer before ordering the remainder of piles.

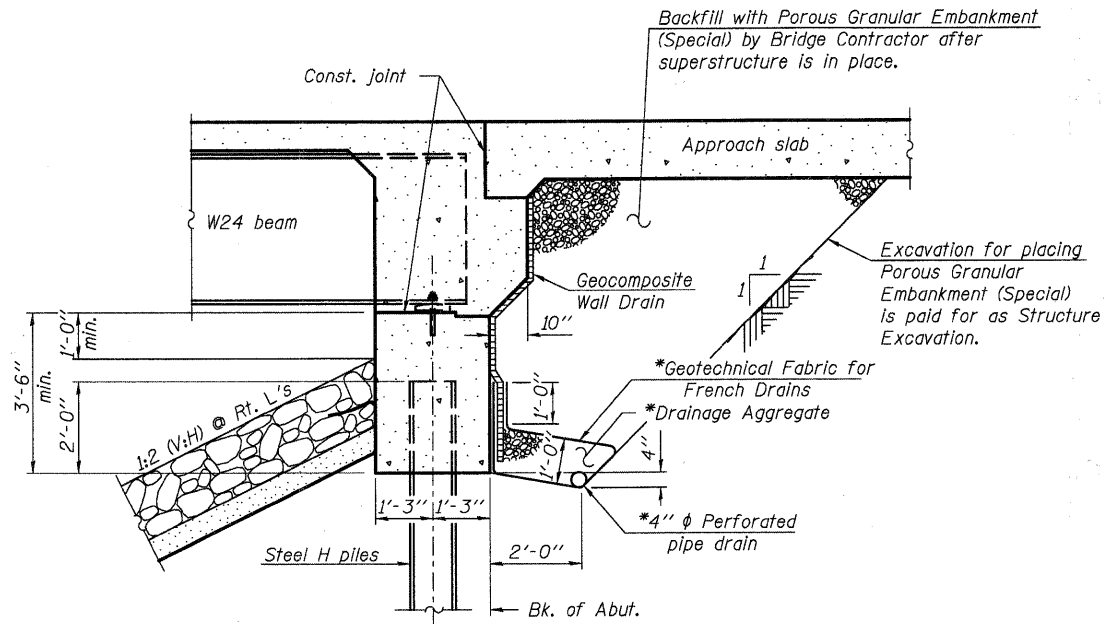

SECTION THRU INTEGRAL ABUTMENT

*Included in the cost of Pipe Underdrains for Structures.

Note:
All drainage system components shall extend to 2'-0" from the end of each wingwall except an outlet pipe shall extend until intersecting with the side slopes. The pipes shall drain into concrete headwalls. (See Article 601.05 of the Standard Specifications and Highway Standard 601101).

TOTAL BILL OF MATERIAL

ITEM	UNIT	SUPER	SUB	TOTAL
Stone Riprap, Class A4	Sq. Yd.		517	517
Filter Fabric	Sq. Yd.		517	517
Removal of Existing Structures	Each	1		1
Bridge Rail Removal	Foot	186		186
Structure Excavation	Cu. Yd.		186	186
Cofferdam Excavation	Cu. Yd.		58	58
Cofferdam, Location 1	Each		1	1
Concrete Structures	Cu. Yd.		85.7	85.7
Concrete Superstructure	Cu. Yd.	237.5		237.5
Bridge Deck Grooving	Sq. Yd.	553		553
Seal Coat Concrete	Cu. Yd.		24.8	24.8
Concrete Encasement	Cu. Yd.		4.2	4.2
Protective Coat	Sq. Yd.	671		671
Furnishing and Erecting Structural Steel	L. Sum		1	1
Stud Shear Connectors	Each	1,920		1,920
Reinforcement Bars, Epoxy Coated	Pound	57,260	7,280	64,540
Bar Splacers	Each	72		72
Furnishing Steel Piles HP 12x53	Foot		300	300
Furnishing Steel Piles HP 14x73	Foot		192	192
Driving Piles	Foot		300	300
Test Pile Steel HP 12x53	Each		2	2
Pile Shoes	Each		12	12
Name Plates	Each	1		1
Anchor Bolts, 1"	Each		30	30
Geocomposite Wall Drain	Sq. Yd.		54	54
Pipe Underdrains for Structures 4"	Foot		145	145
Porous Granular Embankment, Special	Cu. Yd.		97	97
Setting Piles in Rock	Each		6	6
Channel Excavation	Cu. Yd.		416	416

Revised 2-24-11

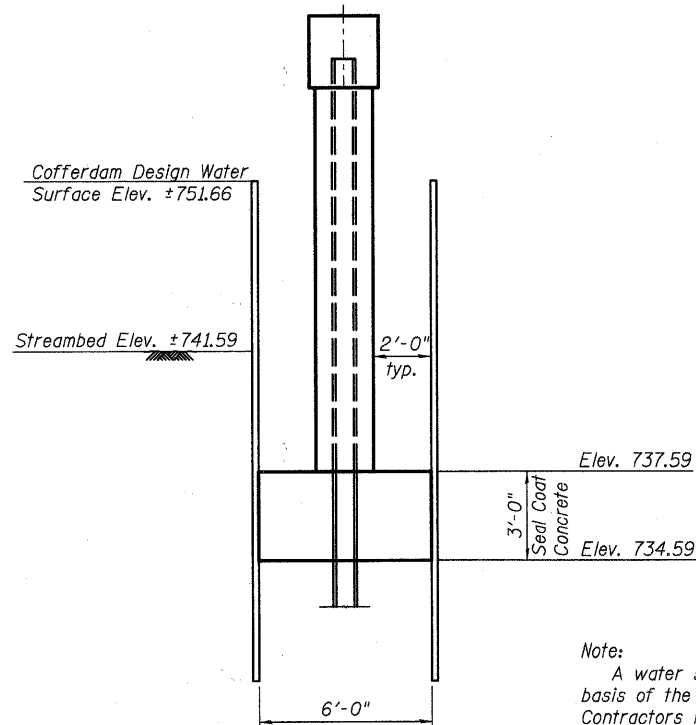

COFFERDAM DETAIL

Note:
A water surface elevation of ±748.66 will be the basis of the cofferdam design. It is the Contractor's responsibility to provide a design for the cofferdam, verification of seal coat thickness shown and all other required appurtenances, subject to approval of the Engineer. Plan dimensions of cofferdam are 6'-0" x 37'-2".

DESIGNED - AEU
CHECKED - DLS
DRAWN - AWH
CHECKED - AEU

**GENERAL DATA
STRUCTURE NO. 045-3020**

WILLS BURKE KELSEY ASSOCIATES LTD. 116 West Main Street, Suite 201 St. Charles, Illinois 60174 (630) 443-7755	SHEET NO. 2	F.A.U.	SECTION	COUNTY	TOTAL SHEETS	SHEET NO.
	21 SHEETS	2332	03-14185-02-BR	KANE	73	26
		FED. ROAD DIST. NO.		ILLINOIS	FED. AID PROJECT	
		CONTRACT NO. 63521				