

As Received from Sp...

119

INDEX OF SHEETS

- 1 COVER SHEET
- 2 GENERAL NOTES
- 3-8 SUMMARY OF QUANTITIES
- 9-11 TYPICAL SECTIONS
- 12-22 SCHEDULE OF QUANTITIES
- 23-42 PLAN VIEWS
- 43-54 STAGING PLANS
- 55-125 BRIDGE PLANS
- 126 WINGWALL DETAIL S.N. 057-0801
- 127-129 C.H. 29 DETAILS
- 130-139 MISCELLANEOUS DETAILS

STANDARDS

- 000001-03 Standard Symbols, Abbreviations And Patterns
- 001001 Areas of Reinforcement Bars
- 001006 Decimal of an Inch and of a Foot
- 420001-02 Pavement Joints
- 420401-02 Bridge Approach Pavement
- 420701 Pavement Fabric
- 442001-02 Class A Patches
- 442101-02 Class B Patches
- 482006 Bituminous Shoulder - Adjacent To Rigid Pavement
- 482101 Rumble Strip for PCC or Bituminous Shoulder
- 542301 Precast Reinforced Concrete Flared End Section
- 601001 Sub-Surface Drains
- 601101 Concrete Headwall For Pipe Drains
- 605301-02 PC Concrete Islands And Medians
- 609001-01 Bridge Approach Shoulder Pavement And Drain
- 630001-02 Steel Plate Beam Guardrail
- 630201-01 PCC/Bit Stabilization At Steel Plate Beam Guardrail
- 630301 Shoulder Widening for Type I Guardrail Terminals
- 631031-02 Traffic Barrier Terminal, Type 6
- 635001 Delineators
- 635006 Reflector and Terminal Marker Placement
- 635011 Reflector Marker and Mounting Details
- 665001 Woven Wire Fence
- 701001 Off-Road Operations, 2-L, 2-W, 4.5 m (15') Min. Away, For Speeds > 45 MPH
- 701006-01 Off-Road Operations, 2-L, 2-W, 4.5 m (15') To 600 mm (24") Away, Speeds > 45 MPH
- 701011 Off-Road Moving Operations, 2-L, 2-W, Day Only, For Speeds > 45 MPH
- 70101 Off-Road Operations, Multilane, Less Than 4.5 m (15') Away, Speeds > 45 MPH
- 701106 Off-Road Operations, Multilane, More Than 4.5 m (15') Away, For Speeds > 45 MPH
- 701201-01 Lane Closure, 2L, 2W, Day Only, On-Rd To 600 mm (24") Off-Rd, For Speeds > 45 MPH
- 701316-01 Lane Closure, 2-L, 2-W, Bridge Repair, For Speeds > 45 MPH
- 701326-01 Lane Closure, 2-L, 2-W, Pavement Widening, For Speeds > 45 MPH
- 701401 Lane Closure Multilane with Barrier, For Speeds > 45 MPH
- 701402 Lane Closure Multilane with Barrier
- 701411-01 Lane Closure, Multilane, At Entrance Or Exit Ramp, For Speeds > 45 MPH
- 701426-01 Lane Closure, Multilane, Intermittent Or Moving Operation, For Speeds > 45 MPH
- 702001-01 Traffic Control Devices
- 704001 Temporary Concrete Barrier
- 720011 Metal Posts (signs, markers, and delineators)
- 780001-01 Typical Pavement Markings
- 781001-02 Typical Applications, Raised Reflective Pavement Markers
- 840006 Traffic Signal Mounting Details
- 846001 Detector Loop Installations
- 846006 Typical Layout For Detection Loops

MICROFILMED _____
 REEL NUMBER _____
 AWARDED _____
 RESIDENT ENGINEER _____
 AS BUILT CHANGES WERE MADE
 ON THE FOLLOWING SHEETS _____

JULIE 1-800-892-0123

DISTRICT 3 NO. (815) 434-6131

PROJECT ENGINEER: STEVE ANDREWS
 UNIT CHIEF: MICHELE LINDEMANN
 TOWNSHIP: NORMAL, TOWANDA & MONEY CREEK

CONTRACT NO. 86963

STATE OF ILLINOIS
 DEPARTMENT OF TRANSPORTATION
 DIVISION OF HIGHWAYS
**PLANS FOR PROPOSED
 FEDERAL AID HIGHWAY**

F.A.I. ROUTE 55 (I-55)
 SECTION (57-3-1, 57-3, 57-3-2, 57-2)RS
 McLEAN COUNTY PROJ. ACIM-55-5(99)166

C-93-001-00

END IMPROVEMENT
STA. 625+00

S.N. 057-0169
 S.N. 057-0170
 STA. 608+35.40

S.N. 057-0166
 STA. 571+30

S.N. 057-0163
 S.N. 057-0164
 STA. 322+95

S.N. 057-0162
 STA. 259+36.01

BEGIN IMPROVEMENT
 STA. 53+75 S.B.
 STA. 39+00 N.B.

S.N. 057-0167
 S.N. 057-0168
 STA. 588+37.50

S.N. 057-0801
 STA. 571+67

S.N. 057-0165
 STA. 464+85.00

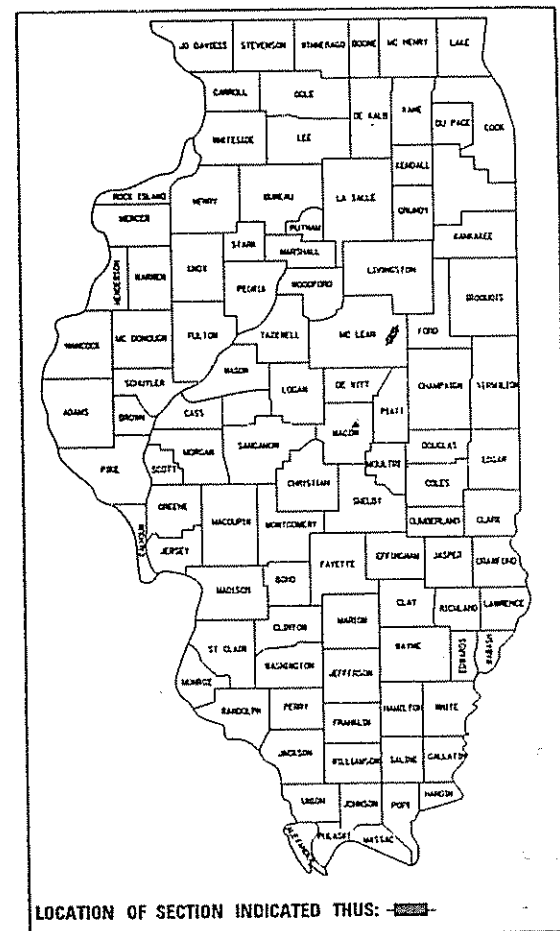
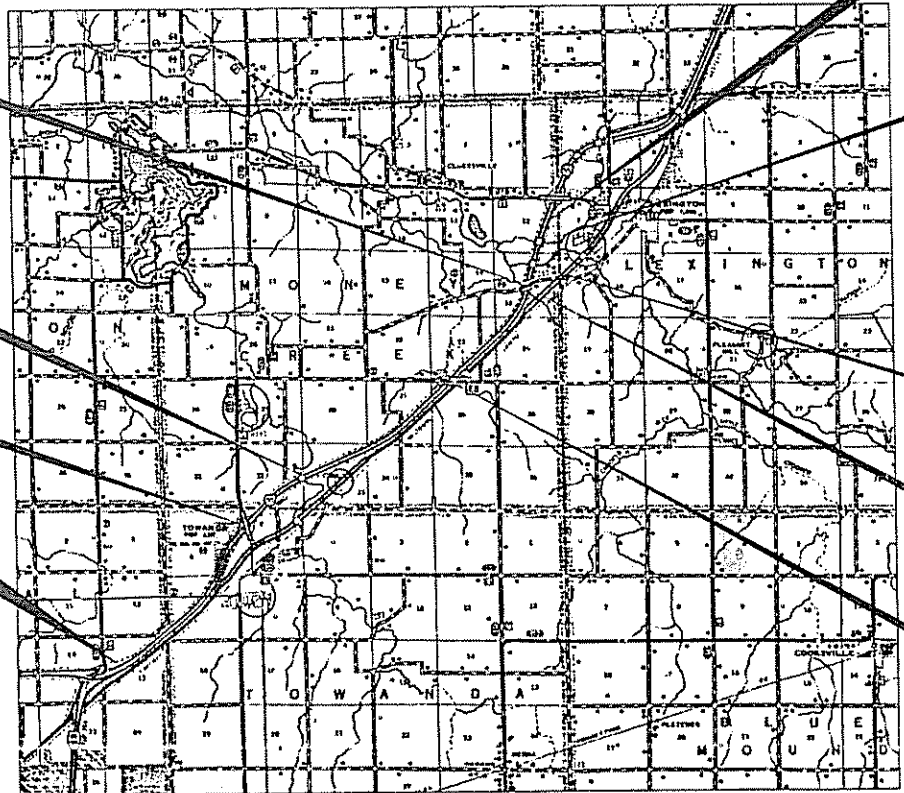

LOCATION OF SECTION INDICATED THUS: [Symbol]
 DESIGN DESIGNATION - INTERSTATE
 ADT (2000) = 27300
 P.V. - 79.5%
 S.U. - 2.5%
 M.U. - 18.0%

STATE OF ILLINOIS
 DEPARTMENT OF TRANSPORTATION
 DIVISION OF HIGHWAYS

SUBMITTED JANUARY 13, 2000
James P. Sl... DISTRICT ENGINEER
February 4, 2000
Bill... ENGINEER OF DESIGN AND ENVIRONMENT
February 4, 2000
James P. Sl... DIRECTOR, DIVISION OF HIGHWAYS

GROSS & NET LENGTH OF IMPROVEMENT:
 S.B. = 54,100.19 FT. = 10.25 MI.
 N.B. = 52,951.28 FT. = 10.03 MI.

STATION EQUATION S.B. 51+14.53 BK. = 86+60.28 AH.
 STATION EQUATION N.B. 36+03.18 BK. = 98+45.54 AH.

JAN. 13, 2000
VEDD21001 SHEETS.DGN

F.A.I. RTE.	SECTION	COUNTY	TOTAL SHEETS	SHEET NO.
55		McLEAN	139	7
STA.		TO STA.		
FED. ROAD DIST. NO.		ILLINOIS	FED. AID PROJECT	
* (S7-3-1,57-3,57-3-2,57-2)RS				

CODE NO.	SUMMARY OF QUANTITIES ITEM	CONSTRUCTION CODE TYPE:	1000			SFTY-2A
			UNIT	TOTAL QUANTITY	TOTAL ROADWAY	TOTAL BRIDGE
Δ 78000620	THERMOPLASTIC PAVEMENT MARKING - LINE 18"		FOOT	48	48	
Δ 78100100	RAISED REFLECTIVE PAVEMENT MARKER		EACH	3028	3028	
78200300	PRISMATIC CURB REFLECTOR		EACH	1160	1160	
78200410	GUARDRAIL MARKERS, TYPE A		EACH	30	30	
78200500	BARRIER WALL MARKERS		EACH	48	48	
78201000	TERMINAL MARKER - DIRECT APPLIED		EACH	12	12	
78300100	PAVEMENT MARKING REMOVAL		SO FT	820	820	
78300200	RAISED REFLECTIVE PAVEMENT MARKER REMOVAL		EACH	3028	3028	
Δ 81012400	CONDUIT IN TRENCH, 1 1/4" DIA., PVC		FOOT	114	114	
Δ 81500100	GULFBOX JUNCTION		EACH	2	2	
Δ 81500105	GULFBOX JUNCTION REMOVAL		EACH	2	2	
Δ 82401200	ELECTRIC CABLE IN CONDUIT, SIGNAL NO. 14, 1C		FOOT	48	48	
Δ 82401510	ELECTRIC CABLE IN CONDUIT, LEAD-IN, NO. 18 3 PAIR		FOOT	92	92	
Δ 84700400	DETECTOR LOOP, SPECIAL		FOOT	134	134	
Δ 86301000	TERMINAL FACILITY		EACH	1	1	
Δ 86800100	TRENCH AND BACKFILL FOR ELECTRICAL WORK		FOOT	72	72	
Δ 86800105	TRENCH AND BACKFILL FOR ELECTRICAL WORK (SPECIAL)		FOOT	32	32	
X0300247	REMOVE WOOD POST		EACH	12	12	
X0321468	PLUG EXISTING DECK DRAINS		EACH	100		100
X0321744	SILICONE JOINT SEAL- 2"		FOOT	159		159
X0322194	POLYMER MODIFIED PORTLAND CEMENT MORTAR		SO FT	22		22
X0322729	MATERIAL TRANSFER DEVICE		TON	97324	97324	
X0329834	PAVED DITCH BREAKING		SO FT	56	56	
X0976500	END SECTIONS REMOVED		EACH	3	3	
Δ X4066538	^{POLYMERIZED} BITUMINOUS CONCRETE SURFACE COURSE, SUPERPAVE, MIX "E", N90		TON	28325	28325	
X4066618	BITUMINOUS CONCRETE BINDER COURSE, SUPERPAVE, IL-19.0, N90		TON	32377	32377	
X4066718	LEVELING BINDER (HAND METHOD), SUPERPAVE IL-19.0, N90		TON	159	159	
X4067400	OC/QA BITUMINOUS		TON	117293	117293	
X4207400	OC/QA CONCRETE		CU YD	3131	2495	636

**REVISED
PLAN SHEETS**

Δ SPECIALTY ITEMS
ΔΔ SFTY-3N

Δ REVISIONS 2/22/00

SUMMARY OF QUANTITIES

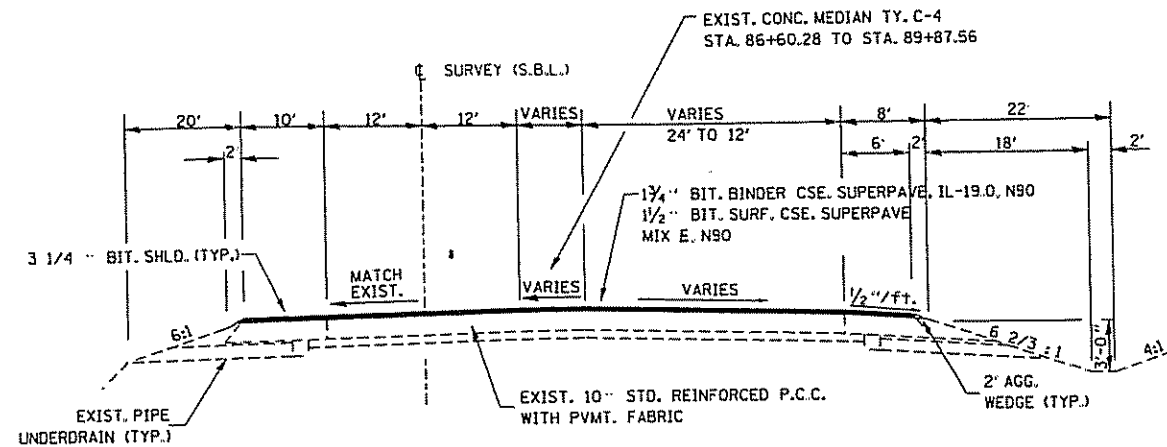

TYPICAL CROSS SECTION (S.B.L.)

STA. 53+75.00 TO STA. 51+14.53 (S.B.L.) = STA. 86+60.28 (S.B.L.)
STA. 86+60.28 (S.B.L.) TO STA. 95+60.28 (S.B.L.)

MIX	AC/PG GRADE	MAXIMUM % RAP	DESIGN AIR VIODS	MIXTURE COMPOSITION	FRICTION AGGREGATE
BINDER SUPERPAVE	PG64-22	10%	4% @ Nd = 90	IL - 19.0	
△ SURFACE SUPERPAVE <i>Partnered</i>	SBS-PG70-22	0%	4% @ Nd = 90	IL-12.5 OR IL-9.5	MIXTURE E
BIT. SHOULDER (BOTTOM LIFT)	PG64-22	25%	3%		
BIT. SHOULDER 10"	PG64-22	25%	3%		
BIT. SHOULDER CLASS I, TYPE 3, MIX. C (TOP LIFT)	PG64-22	15%	3%		
BIT. BASE CSE. 8"	PG64-22	25%	3%		

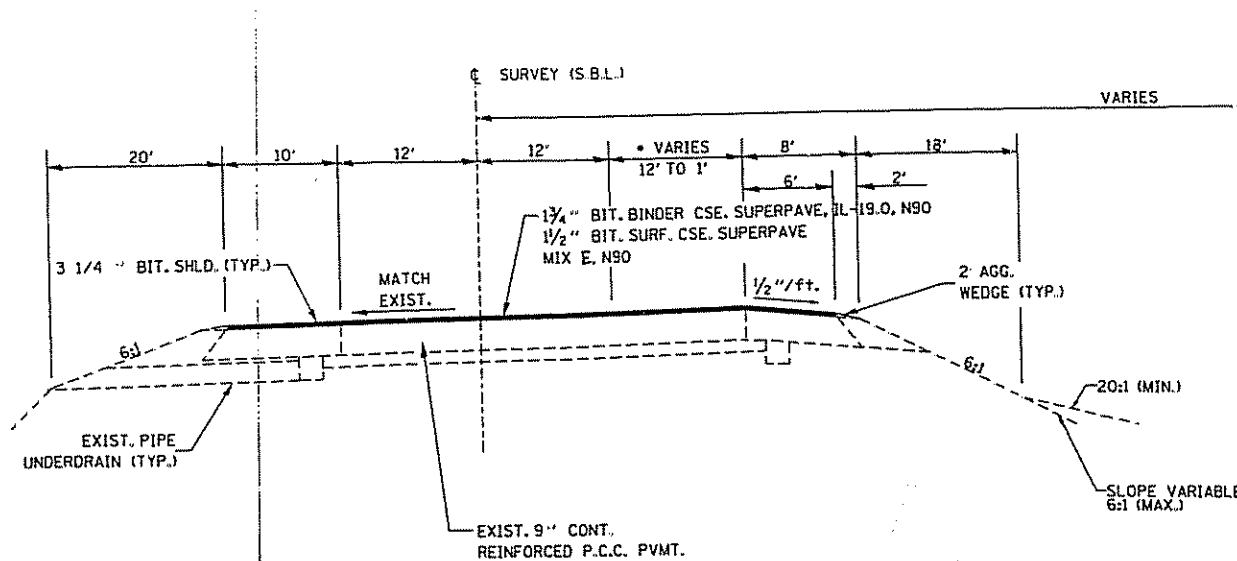

TYPICAL CROSS SECTION (S.B.L.)

STA. 95+60.28 (S.B.L.) TO STA. 126+60.28 (S.B.L.)
* VARIES STA. 120+60.28 (S.B.L.) TO STA. 126+60.28 (S.B.L.)

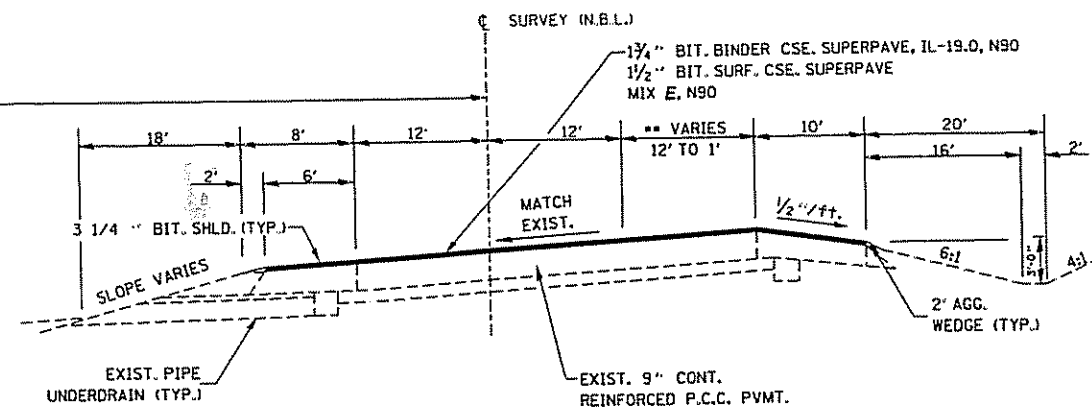

TYPICAL CROSS SECTION (N.B.L.)

STA. 39+00.00 (N.B.L.) TO STA. 36+03.18 (N.B.L.) = STA. 98+45.54 (N.B.L.)
STA. 98+45.54 (N.B.L.) TO STA. 117+48.72 (N.B.L.)
** VARIES STA. 111+48.72 (N.B.L.) TO STA. 117+48.72 (N.B.L.)

F.A.I. RTE.	SECTION	COUNTY	TOTAL SHEETS	SHEET NO.
55	•	MCLEAN	139	2
STA.	TO STA.			
FED. ROAD DIST. NO.	ILLINOIS	FED. AID PROJECT		
• 57-3-1, 57-3, 57-3-2, 57-21 RS				

GENERAL NOTES

THE THICKNESS OF BITUMINOUS MIXTURES SHOWN ON THE PLANS IS THE NOMINAL THICKNESS. DEVIATIONS FROM THE NOMINAL THICKNESS WILL BE PERMITTED WHEN SUCH DEVIATIONS OCCUR DUE TO IRREGULARITIES IN THE EXISTING SURFACE OR BASE ON WHICH THE BITUMINOUS MIXTURE IS PLACED.

THE BITUMINOUS SURFACE OF ALL MAILBOX TURNOUTS, PRIVATE ENTRANCES, COMMERCIAL ENTRANCES, AND SIDE ROADS SHALL BE MADE NEATLY, IN A WORKMANLIKE MANNER, AND SHALL ACCURATELY CONFORM TO THE SHAPES AND DIMENSIONS SHOWN ON THE PLAN DETAILS. IF REQUIRED BY THE ENGINEER, THE CONTRACTOR SHALL BE REQUIRED TO SAW CUT THE BITUMINOUS SURFACE TO CONFORM TO THE SHAPES AND DIMENSIONS SHOWN ON THE PLAN DETAILS. THIS WORK SHALL BE INCLUDED IN THE COST OF THE BITUMINOUS SURFACE.

THE BASE COURSE WIDENING SHALL BE CARRIED THROUGH ALL ENTRANCES, SIDE ROADS, AND MAILBOX TURNOUTS. EXCEPTIONS WILL BE SHOWN ON THE PLANS.

BEFORE ORDERING PIPE CULVERTS OR PIPE DRAINS, THE CONTRACTOR SHALL CONSULT THE ENGINEER FOR EXACT LENGTHS.

AGGREGATE (PRIME COAT): FA 20 MAY BE USED IN ADDITION TO THE GRADATIONS LISTED IN THE 2ND PARAGRAPH OF ARTICLE 1003.03(c).

THE ENGINEER WILL BE THE SOLE JUDGE CONCERNING CURING TIME FOR THE VARIOUS BITUMINOUS LIFTS.

FOR STABILIZATION, ALL TYPE III BARRICADES SHALL REQUIRE A MINIMUM OF FOUR SAND BAGS PER BARRICADE.

WHERE SECTION OR SUBSECTION MONUMENTS ARE ENCOUNTERED, THE ENGINEER SHALL BE NOTIFIED BEFORE SUCH MONUMENTS ARE REMOVED. THE CONTRACTOR SHALL PROTECT AND CAREFULLY PRESERVE ALL MONUMENTS UNTIL AN AUTHORIZED SURVEYOR OR AGENT HAS WITNESSED OR OTHERWISE REFERENCED THEIR LOCATION. THE CONTRACTOR SHALL BE RESPONSIBLE FOR HAVING AN AUTHORIZED SURVEYOR REESTABLISH ANY SECTION OR SUBSECTION MONUMENTS DESTROYED BY HIS OPERATIONS.

SEEDING SHALL NOT BE PERMITTED AT ANY TIME WHEN THE GROUND IS FROZEN, WET, OR IN AN UNTILLABLE CONDITION. LOCATIONS TO BE SEEDED WILL BE DETERMINED BY THE ENGINEER.

THE FINISHED EARTHWORK SHALL HAVE A VEGETATION SUSTAINING SOIL COVERING THE TOP FOUR INCHES IN AREAS TO BE SEEDED OR SODDED. THE VEGETATION SUSTAINING SOIL REQUIRED WILL NOT BE PAID FOR SEPARATELY BUT SHALL BE INCLUDED IN THE COST OF EMBANKMENT.

SHORT TERM PAVEMENT MARKING SHALL BE USED TO OUTLINE EXIT AND ENTRANCE RAMPS FOR THE PRIME COAT APPLICATION AND EACH RESURFACING LIFT.

ON EXISTING PAVEMENT WHICH MAY BE SUPERELEVATED, THE NEW BITUMINOUS PAVEMENT SHALL BE BUILT WITH THE SAME SUPERELEVATION UNLESS NEW SUPERELEVATION RATES ARE GIVEN ON THE PLANS.

ALL ELEVATIONS REFERRING TO U. S. G. S. MEAN SEA LEVEL DATUM.

ANY REFERENCE TO A STANDARD IN THESE PLANS SHALL BE INTERPRETED TO MEAN THE EDITION AS INDICATED BY THE SUBNUMBER LISTED ON THE INDEX OF SHEETS OR THE COPY OF THE STANDARD INCLUDED IN THESE PLANS.

THE FOLLOWING RATES OF APPLICATION HAVE BEEN USED IN CALCULATING PLAN QUANTITIES:

GRANULAR MATERIALS	2.05	TONS / CU YD
BITUMINOUS MAT PRIME COAT	0.08	GAL / SQ YD OR
	3.75	GAL / SQ YD
AGGREGATE PRIME COAT	0.002	TONS / SQ YD
BITUMINOUS CONCRETE SURF CSE	116	LBS / SQ YD / INCH
SHORT TERM PAVEMENT MARKING	10	FT / 100 FT OF
		APPLICATION
MIX FOR CRACKS, JTS & FLGWYS	0.0003	TONS / SQ YD
LEVEL BINDER (HAND METHOD)	0.0005	TONS / SQ YD
LEVEL BINDER (MACHINE METHOD)	116	LBS / SQ YD / INCH

ALL DAMAGE TO DEPARTMENT OWNED UNDERGROUND FACILITIES, CAUSED BY THE CONTRACTOR SHALL BE REPAIRED TO THE SATISFACTION OF THE DEPARTMENT AT THE CONTRACTOR'S EXPENSE. THIS SHALL INCLUDE ALL TEMPORARY REPAIRS REQUIRED TO KEEP THE FACILITY OPERATIONAL WHILE MATERIAL IS BEING OBTAINED TO MAKE PERMANENT REPAIRS. SPLICING OF ELECTRIC CABLE SHALL NOT BE ALLOWED. ELECTRIC CABLE SHALL BE REPLACED FROM POLE TO POLE OR CONTROLLER.

STATE OF ILLINOIS
DEPARTMENT OF TRANSPORTATION
DISTRICT THREE

PREPARED BY: John R. Schaub
DISTRICT STUDIES & PLANS ENGINEER

DATE: January 13, 2000

EXAMINED BY: Richard B. Foy
DISTRICT CONSTRUCTION ENGINEER

Donald R. Jones
DISTRICT MATERIALS ENGINEER

James A. Thacker
DISTRICT OPERATIONS ENGINEER

GENERAL NOTES

F.A.I. RTE.	SECTION	COUNTY	TOTAL SHEETS	SHEET NO.
55		MCLEAN	139	3
STA.		TO STA.		
FED. ROAD DIST. NO.	ILLINOIS	FED. AID PROJECT		
• 157-3-1, 57-3, 57-3-2, 57-2RS				

CODE NO.	SUMMARY OF QUANTITIES ITEM	CONSTRUCTION CODE TYPE:		1000	SFTY-2A
		UNIT	TOTAL QUANTITY	TOTAL ROADWAY	TOTAL BRIDGE
20100110	TREE REMOVAL (6 TO 15 UNITS DIAMETER)	UNIT	83	83	
20200800	GRADING AND SHAPING DITCHES	FOOT	2000	2000	
20300100	CHANNEL EXCAVATION	CU YD	3000		3000
20500150	EMBANKMENT	CU YD	50	50	
20700220	POROUS GRANULAR EMBANKMENT	CU YD	171		171
20800150	TRENCH BACKFILL	CU YD	5	5	
25000200	SEEDING, CLASS 2	ACRE	0.1	0.1	
25000400	NITROGEN FERTILIZER NUTRIENT	POUND	8	8	
25000500	PHOSPHORUS FERTILIZER NUTRIENT	POUND	8	8	
25000600	POTASSIUM FERTILIZER NUTRIENT	POUND	8	8	
25100630	EROSION CONTROL BLANKET	SQ YD	436	436	
28100105	STONE RIPRAP, CLASS A3	SQ YD	74		74
28100107	STONE RIPRAP, CLASS A4	SQ YD	760		760
28100207	STONE DUMPED RIPRAP, CLASS A4	TON	221	221	
28200100	FILTER FABRIC FOR USE WITH RIPRAP	SQ YD	1229	1229	
31100300	SUB-BASE GRANULAR MATERIAL, TYPE A 4"	SQ YD	34	34	
35100100	AGGREGATE BASE COURSE TYPE-A	TON	219	219	
35300300	PORTLAND CEMENT CONCRETE BASE COURSE 8"	SQ YD	60	60	
35500500	BITUMINOUS BASE COURSE 8"	SQ YD	2529	2529	
40600100	BITUMINOUS MATERIALS (PRIME COAT)	GALLON	25686	25686	
40600300	AGGREGATE (PRIME COAT)	TON	636	636	
40600400	MIXTURE FOR CRACKS, JOINTS, AND FLANGEWAYS	TON	96	96	
40600895	CONSTRUCTING TEST STRIP	EACH	2	2	
40600980	BITUMINOUS SURFACE REMOVAL - BUTT JOINT	SQ YD	1414	1414	
40600985	PORTLAND CEMENT CONCRETE SURFACE REMOVAL - BUTT JOINT	SQ YD	1952	1952	
40600990	TEMPORARY RAMP	SQ YD	3792	3792	
42001165	BRIDGE APPROACH PAVEMENT	SQ YD	933	933	
42001200	PAVEMENT FABRIC	SQ YD	496	496	
42001420	BRIDGE APPROACH PAVEMENT CONNECTOR (PCC)	SQ YD	187	187	
44000100	PAVEMENT REMOVAL	SQ YD	794	794	

△ SPECIALTY ITEMS
 △△ SFTY-3N

1/20/00 Summary.dgn
 Jan 11, 2000

F.A.J. RTE.	SECTION	COUNTY	TOTAL SHEETS	SHEET NO.
55	-	McLEAN	139	4
STA.		TO STA.		
FED. ROAD DIST. NO.	ILLINOIS	FED. AID PROJECT		
* 657-3-157-3.57-3-2.57-2HS				

CODE NO.	SUMMARY OF QUANTITIES ITEM	CONSTRUCTION CODE TYPE: UNIT	TOTAL QUANTITY	1000	
				TOTAL ROADWAY	SFTY-2A TOTAL BRIDGE
44000500	COMBINATION CURB AND GUTTER REMOVAL	FOOT	1246	1246	
44000700	APPROACH SLAB REMOVAL	SO YD	373	373	
44000910	BITUMINOUS CONCRETE REMOVAL (DECK)	SO YD	10648		10648
44002020	CONCRETE MEDIAN SURFACE REMOVAL	SO FT	4156	4156	
44003510	MEDIAN REMOVAL PARTIAL DEPTH	SO FT	2572	2572	
44004250	PAVED SHOULDER REMOVAL	SO YD	16556	16556	
44200541	CLASS A PATCHES, TYPE II, 9 INCH	SO YD	2697	2697	
44200545	CLASS A PATCHES, TYPE III, 9 INCH	SO YD	933	933	
44200547	CLASS A PATCHES, TYPE IV, 9 INCH	SO YD	3521	3521	
44200934	CLASS B PATCHES, TYPE II, 8 INCH	SO YD	286	286	
44200942	CLASS B PATCHES, TYPE III, 8 INCH	SO YD	157	157	
44200944	CLASS B PATCHES, TYPE IV, 8 INCH	SO YD	176	176	
44200970	CLASS B PATCHES, TYPE II, 10 INCH	SO YD	194	194	
44200974	CLASS B PATCHES, TYPE III, 10 INCH	SO YD	75	75	
44200976	CLASS B PATCHES, TYPE IV, 10 INCH	SO YD	88	88	
44213000	PATCHING REINFORCEMENT	SO YD	7151	7151	
44213200	SAWCUT	FOOT	36,041	36,041	
48101200	AGGREGATE SHOULDERS, TYPE B	TON	10118	10118	
48200800	BITUMINOUS SHOULDERS 10"	SO YD	13550	13550	
54003000	CONCRETE BOX CULVERTS	CU YD	5		5
48201000	BITUMINOUS SHOULDERS	TON	38276	38276	
50102400	CONCRETE REMOVAL	CU YD	85		85
50104650	SLOPE WALL REMOVAL	SO YD	31		31
50105220	PIPE CULVERT REMOVAL	FOOT	90	90	
50200100	STRUCTURE EXCAVATION	CU YD	209		209
50300120	PREFORMED JOINT SEAL 2 1/2"	FOOT	42		42
50300130	PREFORMED JOINT SEAL 4"	FOOT	126		126
50300150	NEOPRENE EXPANSION JOINT 2"	FOOT	79		79
50300155	NEOPRENE EXPANSION JOINT 2 1/2"	FOOT	164		164
50300160	NEOPRENE EXPANSION JOINT 4"	FOOT	70		70

△ SPECIALTY ITEMS
 △△ SFTY-3N

\ED02100 \ summary.dgn
 Jan 11, 2000

F.A.I. RTE.	SECTION	COUNTY	TOTAL SHEETS	SHEET NO.
55	*	McLEAN	139	5
STA.		TO STA.		
FED. ROAD DIST. NO.		ILLINOIS	FED. AID PROJECT	
* 67-3-1.57-3.57-3-2.57-2HRS				

CODE NO.	SUMMARY OF QUANTITIES ITEM	CONSTRUCTION CODE TYPE:		I000	SFTY-2A
		UNIT	TOTAL QUANTITY	TOTAL ROADWAY	TOTAL BRIDGE
50300255	CONCRETE SUPERSTRUCTURE	CU YD	82		82
50300260	BRIDGE DECK GROOVING	SQ YD	6266		6266
50300300	PROTECTIVE COAT	SQ YD	6770		6770
50300310	ELASTOMERIC BEARING ASSEMBLY, TYPE I	EACH	12		12
50300320	ELASTOMERIC BEARING ASSEMBLY, TYPE II	EACH	12		12
50301245	FORMED CONCRETE REPAIR (DEPTH EQUAL TO OR LESS THAN 5")	SQ FT	220		220
50500405	FURNISHING AND ERECTING STRUCTURAL STEEL	POUND	28290		28290
50500715	JACK AND REMOVE EXISTING BEARINGS	EACH	24		24
50800205	REINFORCEMENT BARS, EPOXY COATED	POUND	17958		17958
51100300	SLOPE WALL 6 INCH	SQ YD	31		31
5030548	TEMPORARY SHEET PILING (REMAIN IN PLACE)	SQ FT	189		189
54213669	PRECAST REINFORCED CONCRETE FLARED END SECTIONS 24"	EACH	2	2	
54213681	PRECAST REINFORCED CONCRETE FLARED END SECTIONS 36"	EACH	1	1	
54246205	INLET BOX, STANDARD 542526	EACH	2	2	
542A0229	PIPE CULVERTS, CLASS A, TYPE 1 24"	FOOT	70	70	
542A0241	PIPE CULVERTS, CLASS A, TYPE 1 36"	FOOT	20	20	
58100200	WATERPROOFING MEMBRANE SYSTEM	SQ YD	3988		3988
59000100	EPOXY CRACK SEALING	FOOT	406		406
60100060	CONCRETE HEADWALL FOR PIPE DRAINS	EACH	603	603	
60100070	SHOULDER REMOVAL AND REPLACEMENT	FOOT	92367	92367	
60107700	PIPE UNDERDRAINS 6"	FOOT	90549	90549	
60108200	PIPE UNDERDRAINS 6" (SPECIAL)	FOOT	4344	4344	
60260100	INLETS TO BE ADJUSTED	EACH	1	1	
60500060	REMOVING INLETS	EACH	2	2	
60608700	COMBINATION CONCRETE CURB AND GUTTER, TYPE M-6.06 (ABUTTING EXISTING PAVEMENT)	FOOT	1096	1096	
60618300	CONCRETE MEDIAN SURFACE, 4 INCH	SQ FT	3780	3780	
60625900	P.C.C. RAMPED MEDIAN TERMINAL	EACH	4	4	
△ 63100085	TRAFFIC BARRIER TERMINAL, TYPE 6	EACH	12	12	
△ 63100167	TRAFFIC BARRIER TERMINAL, TYPE I (SPECIAL) TANGENT	EACH	6	6	

△ SPECIALTY ITEMS
 △△ SFTY-3N

V0002100 Summary.dgn
 Jan 11, 2008

F.A.I. RTE.	SECTION	COUNTY	TOTAL SHEETS	SHEET NO.
55	*	McLEAN	139	6
STA.		TO STA.		
FED. ROAD DIST. NO.		ILLINOIS	FED. AID PROJECT	
* IST-3-L-57-3,57-3-2,57-2RS				

CODE NO.	SUMMARY OF QUANTITIES ITEM	CONSTRUCTION CODE TYPE:	UNIT	TOTAL QUANTITY	1000	SFTY-2A
					TOTAL ROADWAY	TOTAL BRIDGE
Δ 63200310	GUARD RAIL REMOVAL		FOOT	1023	1023	
Δ 63301210	REMOVE AND RE-ERECT STEEL PLATE BEAM GUARD RAIL, TYPE A		FOOT	750	750	
63500105	DELINEATORS		EACH	404	404	
63500120	DELINEATOR REMOVAL		EACH	404	404	
66500105	WOVEN WIRE FENCE, 4'		FOOT	830	830	
66502300	WOVEN WIRE FENCE REMOVAL		FOOT	830	830	
67000400	ENGINEER'S FIELD OFFICE, TYPE A		CAL MO	16	16	
67100100	MOBILIZATION		L SUM	1	0.8	0.2
70100100	TRAFFIC CONTROL AND PROTECTION, STANDARD 701316		EACH	2		2
70100207	TRAFFIC CONTROL AND PROTECTION, STANDARD 701402		EACH	6	6	
70100420	TRAFFIC CONTROL AND PROTECTION, STANDARD 701411		EACH	4	4	
70100450	TRAFFIC CONTROL AND PROTECTION, STANDARD 701201		L SUM	1	1	
70100500	TRAFFIC CONTROL AND PROTECTION, STANDARD 701326		L SUM	1		1
70100700	TRAFFIC CONTROL AND PROTECTION, STANDARD 701406		L SUM	1	1	
70100800	TRAFFIC CONTROL AND PROTECTION, STANDARD 701401		L SUM	1	1	
70103815	TRAFFIC CONTROL SURVEILLANCE		CAL DA	55	55	
Δ 70106500	TEMPORARY BRIDGE TRAFFIC SIGNALS		EACH	2		2
70300100	SHORT-TERM PAVEMENT MARKING		FOOT	22610	22610	
Δ 70300220	TEMPORARY PAVEMENT MARKING - LINE 4"		FOOT	234528	234528	
Δ 70300240	TEMPORARY PAVEMENT MARKING - LINE 6"		FOOT	28265	28265	
Δ 70300250	TEMPORARY PAVEMENT MARKING - LINE 8"		FOOT	4138	4138	
70300520	PAVEMENT MARKING TAPE, TYPE III 4"		FOOT	8637	8637	
70301000	WORK ZONE PAVEMENT MARKING REMOVAL		SQ FT	6647	6647	
70400100	TEMPORARY CONCRETE BARRIER		FOOT	3840	3840	
70400200	RELOCATE TEMPORARY CONCRETE BARRIER		FOOT	3882	3882	
70400300	TEMPORARY CONCRETE BARRIER, TERMINAL SECTION		EACH	6	6	
Δ 78000200	THERMOPLASTIC PAVEMENT MARKING - LINE 4"		FOOT	234528	234528	
Δ 78000400	THERMOPLASTIC PAVEMENT MARKING - LINE 6"		FOOT	28265	28265	
Δ 78000500	THERMOPLASTIC PAVEMENT MARKING - LINE 8"		FOOT	4138	4138	

Δ SPECIALTY ITEMS
 ΔΔ SFTY-3N

LEDC0100 \ Summary.dgn
Jan 11, 2000

F.A.I. RTE.	SECTION	COUNTY	TOTAL SHEETS	SHEET NO.
55	*	McLEAN	139	7
STA.		TO STA.		
FED. ROAD DIST. NO.		ILLINOIS	FED. AID PROJECT	
* IST-3-1,57-3,57-3-2,57-2RS				

CODE NO.	SUMMARY OF QUANTITIES ITEM	CONSTRUCTION CODE TYPE:	UNIT	TOTAL QUANTITY	1000		SFTY-2A
					TOTAL ROADWAY	TOTAL BRIDGE	
Δ 78000620	THERMOPLASTIC PAVEMENT MARKING - LINE 18"		FOOT	48	48		
Δ 78100100	RAISED REFLECTIVE PAVEMENT MARKER		EACH	3028	3028		
78200300	PRISMATIC CURB REFLECTOR		EACH	1160	1160		
78200410	GUARDRAIL MARKERS, TYPE A		EACH	30	30		
78200500	BARRIER WALL MARKERS		EACH	48	48		
78201000	TERMINAL MARKER - DIRECT APPLIED		EACH	12	12		
78300100	PAVEMENT MARKING REMOVAL		SQ FT	820	820		
78300200	RAISED REFLECTIVE PAVEMENT MARKER REMOVAL		EACH	3028	3028		
Δ 81012400	CONDUIT IN TRENCH, 1 1/4" DIA., PVC		FOOT	114	114		
Δ 81500100	GULFBOX JUNCTION		EACH	2	2		
Δ 81500105	GULFBOX JUNCTION REMOVAL		EACH	2	2		
Δ 82401200	ELECTRIC CABLE IN CONDUIT, SIGNAL NO. 14, 1C		FOOT	48	48		
Δ 82401510	ELECTRIC CABLE IN CONDUIT, LEAD-IN, NO. 18 3 PAIR		FOOT	92	92		
Δ 84700400	DETECTOR LOOP, SPECIAL		FOOT	134	134		
Δ 86301000	TERMINAL FACILITY		EACH	1	1		
Δ 86800100	TRENCH AND BACKFILL FOR ELECTRICAL WORK		FOOT	72	72		
Δ 86800105	TRENCH AND BACKFILL FOR ELECTRICAL WORK (SPECIAL)		FOOT	32	32		
X0300247	REMOVE WOOD POST		EACH	12	12		
X0321468	PLUG EXISTING DECK DRAINS		EACH	100		100	
X0321744	SILICONE JOINT SEAL - 2"		FOOT	159		159	
X0322194	POLYMER MODIFIED PORTLAND CEMENT MORTAR		SQ FT	22		22	
X0322729	MATERIAL TRANSFER DEVICE		TON	97324	97324		
X0329834	PAVED DITCH BREAKING		SQ FT	56	56		
X0976500	END SECTIONS REMOVED		EACH	3	3		
X4066	BITUMINOUS CONCRETE SURFACE COURSE, SUPERPAVE, MIX "E", N90		TON	28325	28325		
X4066618	BITUMINOUS CONCRETE BINDER COURSE, SUPERPAVE, IL-19.0, N90		TON	32377	32377		
X4066718	LEVELING BINDER (HAND METHOD), SUPERPAVE IL-19.0, N90		TON	159	159		
X4067400	OC/QA BITUMINOUS		TON	117293	117293		
X4207400	OC/QA CONCRETE		CU YD	3131	2495	636	

Δ SPECIALTY ITEMS
ΔΔ SFTY-3N

\ED02100 \ summary.dgn
Jan 11, 2000

F.A.I. RITE	SECTION	COUNTY	TOTAL SHEETS	SHEET NO.
55	*	MCLEAN	139	8
STA.	TO STA.			
FED. ROAD DIST. NO.	ILLINOIS	FED. AID PROJECT		
* 157-3-1.57-3.57-3-2.57-2MS				

CODE NO.	SUMMARY OF QUANTITIES ITEM	CONSTRUCTION CODE TYPE:		1000	SFTY-2A
		UNIT	TOTAL QUANTITY	TOTAL ROADWAY	TOTAL BRIDGE
X4422025	PARTIAL DEPTH REMOVAL, 2"	SO YD	911	911	
X7011005	TRAFFIC CONTROL AND PROTECTION FOR TEMPORARY DETOUR	L SUM	1		1
X7015000	CHANGEABLE MESSAGE SIGN	CAL MO	16	16	
Z0002600	BAR SPLICERS	EACH	196		196
Z0006110	BRIDGE DECK MICROSILICA CONCRETE OVERLAY	SO YD	6532		6532
* Z0010615	CLEANING EXISTING INLETS	EACH	8	8	
Z0012200	CONCRETE BRIDGE DECK SCARIFICATION (1/2 INCH)	SO YD	6506		6506
Z0013825	CONTROLLED LOW-STRENGTH MATERIAL	CU YD	2	2	
Z0016001	DECK SLAB REPAIR (FULL DEPTH, TYPE I)	SO YD	9		9
Z0016002	DECK SLAB REPAIR (FULL DEPTH, TYPE II)	SO YD	3		3
Z0016200	DECK SLAB REPAIR (PARTIAL)	SO YD	117		117
Z0017202	DOVEL BARS, 1 1/2"	EACH	1408	1408	
Z0031200	JACKING AND CRIBBING	EACH	28		28
Z0047300	PROTECTIVE SHIELD	SO YD	1690		1690
Z0075300	TIE BARS	EACH	1302	1302	
Z0077800	WOODPOSTS	EACH	12	12	
X0322933	SILICONE JOINT SEAL - 2-1/2"	FOOT	94		94
X0322932	SILICONE JOINT SEAL - 1-1/2"	FOOT	94		94
Δ 86301010	TERMINAL FACILITY REMOVAL	EACH	1	1	
ΔΔ Z0056230	SAND MODULE IMPACT ATTENUATORS (REMOVE AND RE-ERECT)	EACH	15	15	
X4421000	PARTIAL DEPTH PATCHING	TON	105	105	
∅ Z0076600	TRAINEES	Hour	500	500	

∅ Y080
 Δ SPECIALTY ITEMS
 ΔΔ SFTY-3N
 * Non Particulating

\ED02100 \summary.dgn
 Jan 11, 2000

SUMMARY OF QUANTITIES

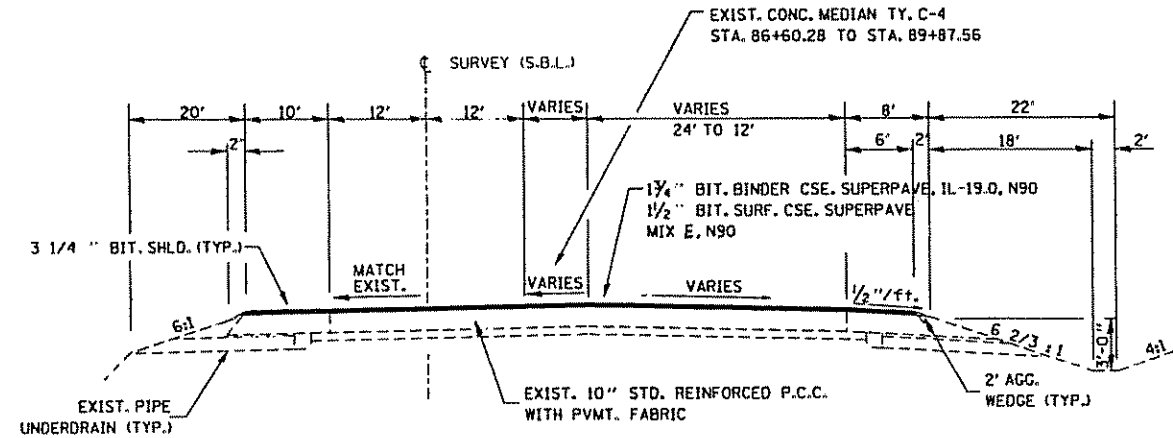

TYPICAL CROSS SECTION (S.B.L.)

STA. 53+75.00 TO STA. 51+14.53 (S.B.L.) = STA. 86+60.28 (S.B.L.)
 STA. 86+60.28 (S.B.L.) TO STA. 95+60.28 (S.B.L.)

MIX	AC/PG GRADE	MAXIMUM % RAP	DESIGN AIR VIODS	MIXTURE COMPOSITION	FRICTION AGGREGATE
BINDER SUPERPAVE	PG64-22	10%	4% @ Nd = 90	IL - 19.0	
SURFACE SUPERPAVE	SBS-P670-22	0%	4% @ Nd = 90	IL-12.5 OR IL-9.5	MIXTURE E
BIT. SHOULDER (BOTTOM LIFT)	PG64-22	25%	3%		
BIT. SHOULDER 10"	PG64-22	25%	3%		
BIT. SHOULDER CLASS I, TYPE 3, MIX. C (TOP LIFT)	PG64-22	15%	3%		
BIT. BASE CSE. 8"	PG64-22	25%	3%		

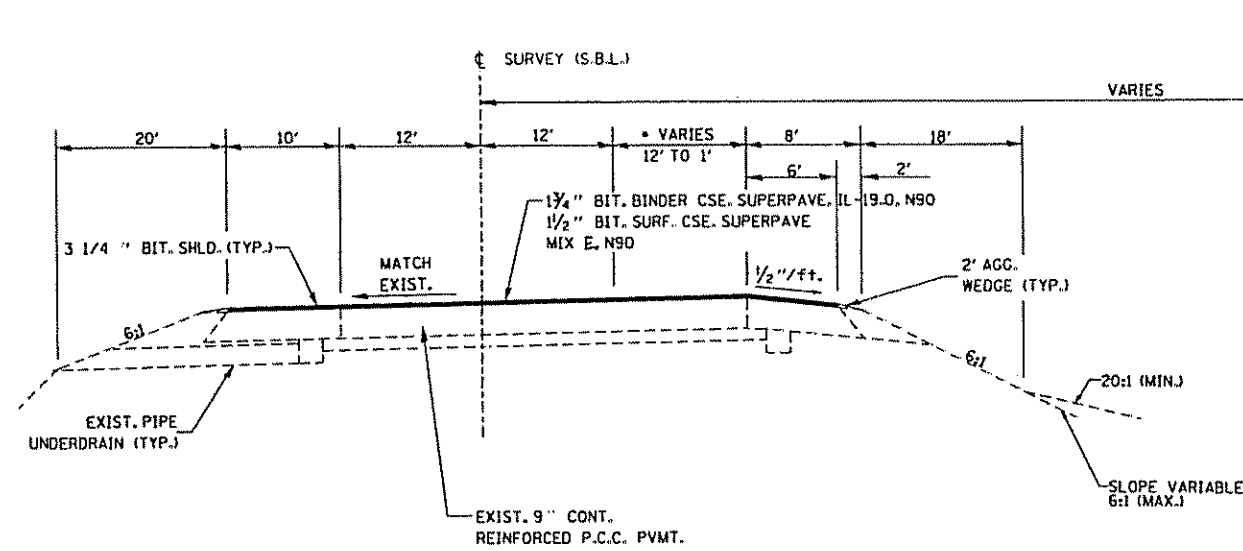

TYPICAL CROSS SECTION (S.B.L.)

STA. 95+60.28 (S.B.L.) TO STA. 126+60.28 (S.B.L.)
 VARIES STA. 120+60.28 (S.B.L.) TO STA. 126+60.28 (S.B.L.)

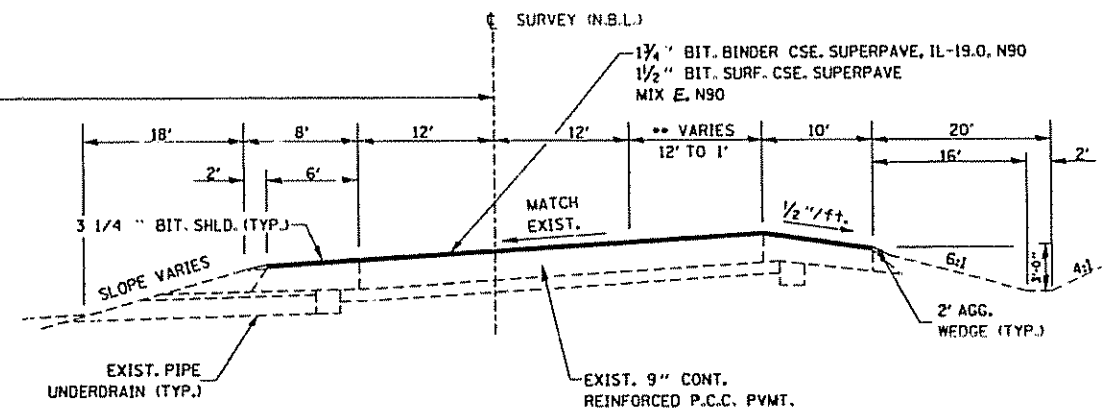

TYPICAL CROSS SECTION (N.B.L.)

STA. 39+00.00 (N.B.L.) TO STA. 36+03.18 (N.B.L.) = STA. 98+45.54 (N.B.L.)
 STA. 98+45.54 (N.B.L.) TO STA. 117+48.72 (N.B.L.)
 VARIES STA. 111+48.72 (N.B.L.) TO STA. 117+48.72 (N.B.L.)

JAN. 11, 2000
 \ED02100\DETAILS.DGN

F.A.I. RTE.	SECTION	COUNTY	TOTAL SHEETS	SHEET NO.
55	•	MCLEAN	139	10
STA.		TO STA.		
FED. ROAD DIST. NO.		ILLINOIS FED. AID PROJECT		
• (57-3-1, 57-3, 57-3-2, 57-2) RS				
SHEET 2 of 3				

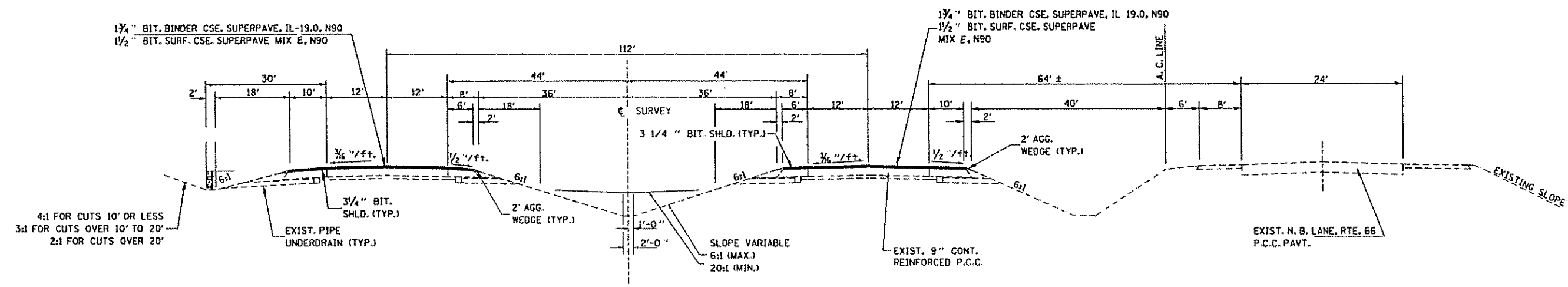

TYPICAL TANGENT CROSS SECTION
 STA. 126+60.28 TO STA. 191+11.81 (SBL)
 STA. 117+48.62 TO STA. 191+11.81 (NBL)

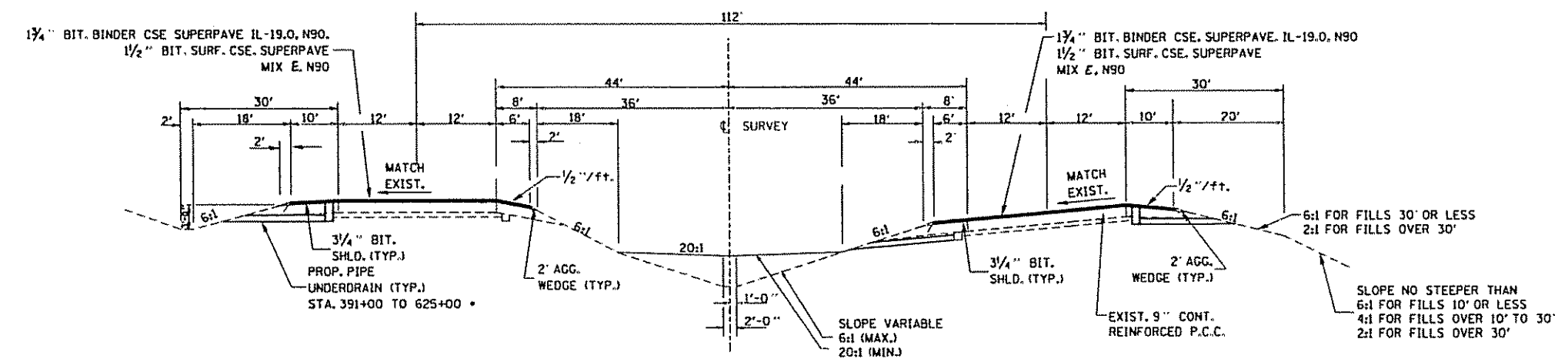

• NOTE:
 EXISTING PIPE UNDERDRAIN IS PRESENT FROM STA. 191+11.81 TO 391+00
 EXIST. C-STONE IS PRESENT FROM STA. 391+00 TO STA. 625+00

TYPICAL SUPERELEVATED CROSS SECTION
 STA. 191+11.81 TO STA. 197+00.00
 STA. 197+00.00 TO STA. 625+00.00 (AT SUPERELEVATION LOCATIONS)

JAN. 11, 2000
 \ED02100\DETAILS.DWG

F.A.I. RTE.	SECTION	COUNTY	TOTAL SHEETS	SHEET NO.
55	•	MCLEAN	139	11
STA.	TO STA.			
FED. ROAD DIST. NO.	ILLINOIS FED. AID PROJECT			
• 157-3-1, 57-3, 57-3-2, 57-21 RS				
SHEET 3 of 3				

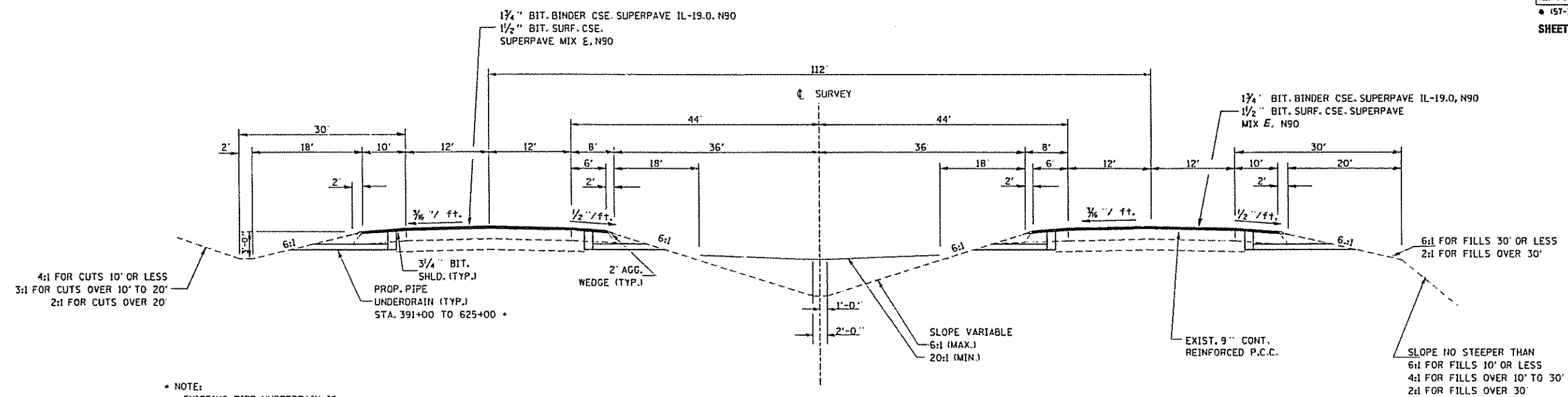

• NOTE:
EXISTING PIPE UNDERDRAIN IS PRESENT FROM STA. 191+11.81 TO 391+00
EXIST. C-STONE IS PRESENT FROM STA. 391+00 TO STA. 625+00

TYPICAL TANGENT CROSS SECTION
STA. 197+00.00 TO STA. 625+00.00 (AT TANGENT LOCATIONS)

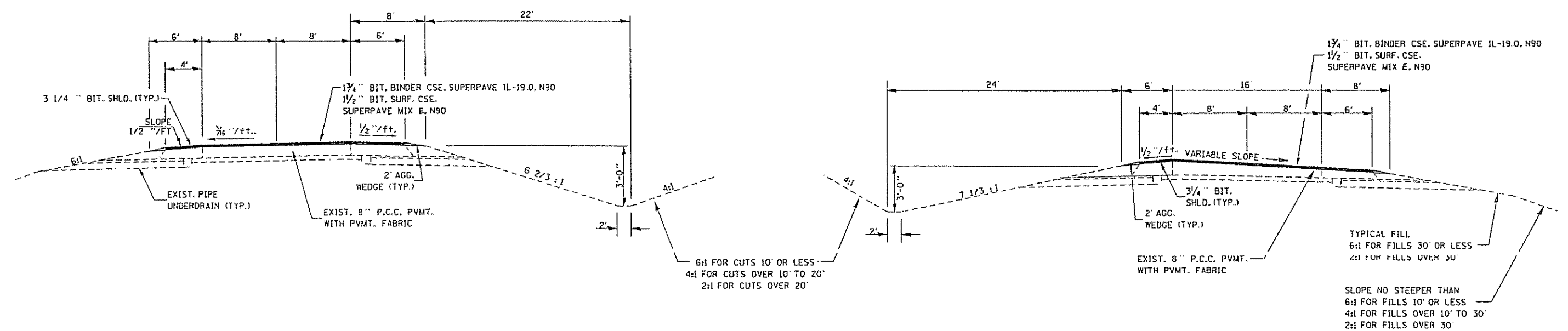

TYPICAL TANGENT RAMP CROSS SECTION

TYPICAL SUPERELEVATED RAMP CROSS SECTION

JAN. 11, 2000
VED02100N.DETAILS.DGN

F.A.I. RTE.	SECTION	COUNTY	TOTAL SHEETS	SHEET NO.
55	•	MCLEAN	139	12
STA.	TO STA.			
FED. ROAD DIST. NO.	ILLINOIS	FED. AID PROJECT		
• 57-3-1, 57-3, 57-3-2, 57-21 R5				

CL. A PATCHING 9 IN.

STATION	TYPE II		TYPE III		TYPE IV		PATCHING REINFORCEMENT SO. YD.	SAW CUT FOOT	TIE BARS EACH
	PASS	DRIVE	PASS	DRIVE	PASS	DRIVE			
	SO. YD.	SO. YD.	SO. YD.	SO. YD.	SO. YD.	SO. YD.			
NORTH BOUND:									
162+57		6.7					6.7	58.0	
165+00		6.7					6.7	58.0	
165+50		6.7					6.7	58.0	
169+10		13.3					13.3	68.0	
169+81		6.7					6.7	58.0	
170+00					26.7		26.7	88.0	11
171+30		6.7					6.7	58.0	
176+78		6.7					6.7	58.0	
177+43		13.3					13.3	68.0	
177+68		6.7					6.7	58.0	
181+45	6.7						6.7	58.0	
182+86		6.7					6.7	58.0	
184+57		6.7					6.7	58.0	
185+07				16.0			16.0	72.0	
186+68	6.7						6.7	58.0	
187+33		6.7					6.7	58.0	
193+61					40.0		40.0	108.0	16
195+10		6.7					6.7	58.0	
199+47		6.7					6.7	58.0	
200+81		13.3					13.3	68.0	
212+06		6.7					6.7	58.0	
214+20		6.7					6.7	58.0	
216+33		6.7					6.7	58.0	
219+00		13.3					13.3	68.0	
219+65	10.7						10.7	64.0	
222+50	6.7						6.7	58.0	
230+50	10.7						10.7	64.0	
236+20	6.7						6.7	58.0	
239+80	6.7						6.7	58.0	
246+70	6.7	6.7					13.4	116.0	
247+10				26.7	26.7		53.4	176.0	11
251+01	6.7	6.7					13.4	116.0	
260+25		6.7					6.7	58.0	
264+80		13.3					13.3	68.0	
SUBTOTAL	68.3	187.1	0.0	16.0	26.7	93.4	391.5	2362.0	38.0

CL. A PATCHING 9 IN. (CONTINUED)

STATION	TYPE II		TYPE III		TYPE IV		PATCHING REINFORCEMENT SO. YD.	SAW CUT FOOT	TIE BARS EACH
	PASS	DRIVE	PASS	DRIVE	PASS	DRIVE			
	SO. YD.	SO. YD.	SO. YD.	SO. YD.	SO. YD.	SO. YD.			
NORTH BOUND:									
271+05	6.7	6.7					13.4	116.0	
288+80		8.0					8.0	60.0	
298+04	13.3	13.3					26.6	136.0	
300+00		6.7					6.7	58.0	
305+87			20.0	20.0			40.0	156.0	
307+38	13.3	13.3					26.6	136.0	
309+26	6.7	6.7					13.4	116.0	
318+69		6.7					6.7	58.0	
326+74	6.7						6.7	58.0	
335+00		6.7					6.7	58.0	
343+40						40.0	40.0	108.0	16
352+63	8.0	8.0					16.0	120.0	
360+25		6.7					6.7	58.0	
372+15	6.7	6.7					13.4	116.0	
394+00				20.0			20.0	78.0	
419+85	6.7						6.7	58.0	
431+59	6.7	6.7					13.4	116.0	
447+62	8.0						8.0	60.0	
478+21		6.7					6.7	58.0	
495+32	6.7						6.7	58.0	
502+65		8.0					8.0	60.0	
514+87	6.7	6.7					13.4	116.0	
527+59		6.7					6.7	58.0	
534+96		13.3					13.3	68.0	
550+64				16.0			16.0	72.0	
563+25		6.7					6.7	58.0	
574+36						66.7	66.7	148.0	26
583+67		6.7					6.7	58.0	
597+98	6.7	6.7					13.4	116.0	
602+84				20.0			20.0	78.0	
610+95		6.7					6.7	58.0	
614+85		6.7					6.7	58.0	
618+87	6.7	6.7					13.4	116.0	
622+45				16.0			16.0	72.0	
SUBTOTAL	109.6	177.8	20.0	92.0	0.0	106.7	506.1	2918.0	42.0
NB TOTAL	177.9	364.9	20.0	108.0	26.7	200.1	897.6	5280.0	80.0

F.A.I. DIST. NO.	SECTION	COUNTY	TOTAL SHEETS	SHEET NO.
55	•	MCLEAN	139	13
STA.		TO STA.		
FED. ROAD DIST. NO.		ILLINOIS	FED. AID PROJECT	
• (57-3-1, 57-3, 57-3-2, 57-2)RS				

CL. A PATCHING 9 IN.

STATION	TYPE II		TYPE III		TYPE IV		PATCHING REINFORCEMENT	SAW CUT FOOT	TIE BARS EACH
	PASS	DRIVE	PASS	DRIVE	PASS	DRIVE			
	SO. YD.	SO. YD.	SO. YD.	SO. YD.	SO. YD.	SO. YD.			
SOUTH BOUND:									
98+25	6.7	6.7					13.4	116.0	
110+09		6.7					6.7	58.0	
110+94		6.7					6.7	58.0	
113+70	10.7	10.7					21.4	128.0	
122+19	13.3						13.3	68.0	
126+69	6.7						6.7	58.0	
128+82	6.7						6.7	58.0	
147+01	6.7						6.7	58.0	
154+61	13.3	13.3					26.6	136.0	
158+37		6.7					6.7	58.0	
162+33	6.7	6.7					13.4	116.0	
164+13	13.3						13.3	68.0	
177+33	13.3	13.3					26.6	136.0	
182+13	6.7						6.7	58.0	
186+51				20.0			20.0	78.0	
187+84	13.3						13.3	68.0	
188+98		6.7					6.7	58.0	
190+73		13.3					13.3	68.0	
194+31		6.7					6.7	58.0	
196+02		6.7					6.7	58.0	
198+75	13.3	13.3					26.6	136.0	
202+44		6.7					6.7	58.0	
204+88		6.7					6.7	58.0	
206+84	6.7	6.7					13.4	116.0	
213+61		6.7					6.7	58.0	
220+62	6.7	6.7					13.4	116.0	
221+13		6.7					6.7	58.0	
223+75	6.7						6.7	58.0	
229+96		6.7					6.7	58.0	
230+52	10.7						10.7	64.0	
239+00				20.0			20.0	78.0	
239+87		13.3					13.3	68.0	
241+66		13.3					13.3	68.0	
242+38				20.0			20.0	78.0	
243+72				20.0			20.0	78.0	
251+38		6.7					6.7	58.0	
251+70					26.7	26.7	53.4	176.0	11
252+28	6.7						6.7	58.0	
252+60		6.7					6.7	58.0	
253+01		6.7					6.7	58.0	
253+86	13.3						13.3	68.0	
254+09	6.7						6.7	58.0	
254+88		6.7					6.7	58.0	
256+22					26.7	26.7	26.7	88.0	11
257+08		6.7					6.7	58.0	
257+81		6.7					6.7	58.0	
258+75	6.7						6.7	58.0	
261+28	6.7						6.7	58.0	
262+28		6.7					6.7	58.0	
262+72		6.7					6.7	58.0	
265+20		13.3					13.3	68.0	
265+94	13.3					26.7	40.0	156.0	11
267+78	13.3	13.3					26.6	136.0	
268+90					66.7	66.7	133.4	296.0	26
269+63						26.7	26.7	88.0	11
270+03	13.3	13.3					26.6	136.0	
271+46		6.7					6.7	58.0	
278+45					26.7	26.7	53.4	176.0	11
279+49		6.7					6.7	58.0	
280+69			20.0	20.0			40.0	156.0	
283+34	13.3	13.3					26.6	136.0	
284+32			20.0				20.0	78.0	
284+71	13.3	13.3					26.6	136.0	
311+59				20.0			20.0	78.0	
SUBTOTAL	268.1	324.5	40.0	120.0	120.1	200.2	1072.9	5496.0	81.0

CL. A PATCHING 9 IN. (CONTINUED)

STATION	TYPE II		TYPE III		TYPE IV		PATCHING REINFORCEMENT	SAW CUT FOOT	TIE BARS EACH
	PASS	DRIVE	PASS	DRIVE	PASS	DRIVE			
	SO. YD.	SO. YD.	SO. YD.	SO. YD.	SO. YD.	SO. YD.			
SOUTH BOUND:									
312+21	13.3	13.3					26.6	136.0	
313+33	6.7	6.7					13.4	116.0	
314+35		6.7					6.7	58.0	
329+53	13.3						13.3	68.0	
332+37					26.7	26.7	53.4	176.0	11
332+98					40.0	40.0	80.0	216.0	16
333+78			20.0	20.0			40.0	156.0	
334+24					40.0	40.0	80.0	216.0	16
335+19					40.0	40.0	80.0	216.0	16
336+36		6.7					6.7	58.0	
336+82		6.7					6.7	58.0	
336+94					40.0	40.0	40.0	108.0	16
338+25		13.3					13.3	68.0	
338+65					40.0	40.0	40.0	108.0	16
339+02		6.7					6.7	58.0	
339+34	13.3	13.3					26.6	136.0	
339+87				20.0			20.0	78.0	
340+83		6.7					6.7	58.0	
341+46		13.3					13.3	68.0	
342+16					40.0	40.0	80.0	216.0	16
343+02				20.0			20.0	78.0	
343+44			20.0	20.0			40.0	156.0	
344+56		13.3					13.3	68.0	
345+36					26.7	26.7	26.7	88.0	11
347+99	13.3	13.3					26.6	136.0	
360+98		6.7					6.7	58.0	
364+44	13.3	13.3					26.6	136.0	
365+00	6.7	6.7					13.4	116.0	
365+25	6.7	6.7					13.4	116.0	
366+55	6.7	6.7					6.7	58.0	
367+78	6.7	6.7					13.4	116.0	
369+83	13.3	13.3					26.6	136.0	
371+05	13.3	13.3					26.6	136.0	
375+05	13.3	13.3					26.6	136.0	
379+22		6.7					6.7	58.0	
380+40	6.7	6.7					13.4	116.0	
382+35		6.7					6.7	58.0	
385+42		6.7					6.7	58.0	
386+50		6.7					6.7	58.0	
391+16				20.0			20.0	78.0	
391+58		6.7					6.7	58.0	
392+08					33.3	33.3	66.6	196.0	13
394+53	13.3	13.3					26.6	136.0	
395+22					26.7	26.7	26.7	88.0	11
396+24					133.3	133.3	133.3	248.0	51
397+25		13.3					13.3	68.0	
399+59		13.3					13.3	68.0	
399+90		6.7					6.7	58.0	
402+51		6.7					6.7	58.0	
403+87				20.0			20.0	78.0	
404+01							26.7	88.0	11
405+23				20.0			20.0	78.0	
406+77				20.0			20.0	78.0	
407+23		13.3					13.3	68.0	
408+28	6.7						6.7	58.0	
409+16		6.7					6.7	58.0	
409+62	13.3						13.3	68.0	
409+89		13.3					13.3	68.0	
411+04				20.0			20.0	88.0	
411+78		6.7					6.7	58.0	
412+32					40.0	40.0	40.0	108.0	16
413+31		13.3					13.3	68.0	
413+88					26.7	26.7	26.7	88.0	11
414+42					33.3	33.3	33.3	98.0	13
SUBTOTAL	179.9	346.8	40.0	180.0	246.7	586.7	1580.1	6460.0	244

CLASS A PATCHING SCHEDULE

JAN. 11, 2000
VE021001.DETAILS.DGN

CL. A PATCHING 9 IN. (CONTINUED)

STATION	TYPE II		TYPE III		TYPE IV		PATCHING REINFORCE- MENT	SAW CUT	TIE BARS
	PASS	DRIVE	PASS	DRIVE	PASS	DRIVE			
	SO. YD.	SO. YD.	SO. YD.	SO. YD.	SO. YD.	SO. YD.			
SOUTH BOUND:									
414+91						26.7	26.7	88.0	11
424+48		13.3					13.3	68.0	
425+33		13.3					13.3	68.0	
425+68		13.3					13.3	68.0	
426+05		6.7					6.7	58.0	
426+56				20.0			20.0	78.0	
427+04				20.0			20.0	78.0	
428+10		6.7					6.7	58.0	
429+00						66.7	66.7	148.0	26
429+64	6.7						6.7	58.0	
429+67		13.3					13.3	68.0	
429+93		13.3					13.3	68.0	
430+41		13.3					13.3	68.0	
430+78				20.0			20.0	78.0	
432+44		6.7					6.7	58.0	
434+00						26.7	26.7	88.0	11
434+20				20.0			20.0	78.0	
436+01		13.3					13.3	68.0	
436+68						53.3	53.3	128.0	21
437+47			20.0				20.0	78.0	
441+30						26.7	26.7	88.0	11
442+15				20.0			20.0	78.0	
443+42						40.0	40.0	108.0	16
444+27		6.7					6.7	58.0	
444+68				20.0			20.0	78.0	
445+14		6.7					6.7	58.0	
446+73		13.3					13.3	68.0	
447+94						26.7	26.7	88.0	11
450+49		13.3					13.3	68.0	
451+24						26.7	26.7	88.0	11
451+80						33.3	33.3	98.0	13
454+31		10.7					10.7	64.0	
455+52				20.0			20.0	78.0	
456+48						53.3	53.3	128.0	21
457+16		6.7					6.7	58.0	
458+72		6.7					6.7	58.0	
459+73						66.7	66.7	148.0	26
460+04	13.3	13.3					26.6	136.0	
460+42				20.0			20.0	78.0	
460+89						26.7	26.7	88.0	11
461+53						26.7	26.7	88.0	11
462+10				20.0			20.0	78.0	
462+68						26.7	26.7	88.0	11
463+35						40.0	40.0	108.0	16
464+00		13.3					13.3	68.0	
464+88						40.0	40.0	108.0	16
465+54		6.7					6.7	58.0	
466+17						26.7	26.7	88.0	11
470+00		6.7					6.7	58.0	
470+80						26.7	26.7	88.0	11
475+39		6.7					6.7	58.0	
476+62		13.3					13.3	68.0	
477+46					26.7	26.7	53.4	176.0	11
478+17						46.7	46.7	118.0	18
478+61					33.3		33.3	98.0	13
479+43				20.0			20.0	78.0	
487+52		6.7					6.7	58.0	
489+41					53.3		53.3	128.0	21
489+66				20.0			20.0	78.0	
490+94						26.7	26.7	88.0	11
491+10	6.7						6.7	58.0	
491+51		6.7					6.7	58.0	
491+82	6.7	6.7					13.4	116.0	
492+21		6.7					6.7	58.0	
SUBTOTAL	33.4	264.1	20.0	220.0	113.3	760.4	1411.2	5332.0	339.0

CL. A PATCHING 9 IN. (CONTINUED)

STATION	TYPE II		TYPE III		TYPE IV		PATCHING REINFORCE- MENT	SAW CUT	TIE BARS	
	PASS	DRIVE	PASS	DRIVE	PASS	DRIVE				
	SO. YD.	SO. YD.	SO. YD.	SO. YD.	SO. YD.	SO. YD.				
SOUTH BOUND:										
493+24				13.3			13.3	68.0		
493+32	6.7						6.7	58.0		
493+84							133.3	133.3	248.0	51
496+56							26.7	26.7	88.0	11
497+81							26.7	26.7	88.0	11
499+26				6.7			6.7	58.0		
500+00				6.7			6.7	58.0		
500+64				6.7			6.7	58.0		
501+91						20.0	20.0	78.0		
502+76				6.7			6.7	58.0		
504+33							33.3	33.3	98.0	13
504+54				6.7			6.7	58.0		
505+28				6.7			6.7	58.0		
506+91							13.3	68.0		
507+78				6.7			6.7	58.0		
508+04						80.0	80.0	168.0		
508+14				6.7			6.7	58.0		
509+12	6.7			13.3			20.0	126.0		
510+32	6.7			6.7			13.4	116.0		
511+92							66.7	66.7	148.0	26
512+84				6.7			6.7	58.0		
513+24						20.0	20.0	78.0		
514+47				6.7			6.7	58.0		
515+00							26.7	26.7	78.0	11
516+74							26.7	26.7	78.0	11
518+67	6.7						33.3	40.0	156.0	13
519+36				6.7			6.7	58.0		
520+35				13.3			13.3	68.0		
521+35				6.7			6.7	58.0		
522+30				13.3			13.3	68.0		
522+81				13.3			13.3	68.0		
522+93				6.7			6.7	58.0		
524+20				6.7			6.7	58.0		
524+36				13.3			13.3	68.0		
525+84				6.7			6.7	58.0		
526+59				13.3			13.3	68.0		
528+80						20.0	20.0	78.0		
530+00	6.7						26.7	136.0		
530+35				6.7			6.7	58.0		
530+66							100.0	100.0	198.0	38
531+50							100.0	100.0	198.0	38
535+01	6.7						26.7	33.4	146.0	11
535+27	6.7			6.7			13.4	116.0		
535+67				6.7			26.7	33.4	146.0	11
575+31	6.7						6.7	58.0		
575+43							53.3	53.3	128.0	21
578+12				6.7			6.7	58.0		
579+48				6.7			6.7	58.0		
579+62				6.7			6.7	58.0		
582+96				6.7			6.7	58.0		
584+16				6.7			6.7	58.0		
584+80				6.7			6.7	58.0		
585+00				6.7			6.7	58.0		
590+56	6.7						6.7	58.0		
593+67							53.3	53.3	128.0	21
593+78				13.3			13.3	68.0		
594+29						20.0	20.0	78.0		
595+00	6.7			13.3			20.0	126.0		
595+59				6.7			6.7	58.0		
597+21				6.7			6.7	58.0		
597+38	13.3						13.3	68.0		
598+17				6.7			6.7	58.0		
598+39	6.7						6.7	58.0		
598+98							10.7	64.0		
SUBTOTAL	87.0	338.0	0.0	100.0	133.4	680.0	1338.4	5442.0	287.0	

CL. A PATCHING 9 IN. (CONTINUED)

STATION	TYPE II		TYPE III		TYPE IV		PATCHING REINFORCEMENT SO. YD.	SAW CUT FOOT	TIE BARS EACH
	PASS	DRIVE	PASS	DRIVE	PASS	DRIVE			
	SO. YD.	SO. YD.	SO. YD.	SO. YD.	SO. YD.	SO. YD.			
SOUTH BOUND:									
600+98		6.7					6.7	58.0	
601+72		13.3					13.3	68.0	
602+97		6.7					6.7	58.0	
606+61		6.7					6.7	58.0	
611+02						53.3	53.3	128.0	21
612+32						26.7	26.7	88.0	11
612+54		6.7					6.7	58.0	
613+47		6.7					6.7	58.0	
618+83		6.7					6.7	58.0	
621+38						53.3	53.3	128.0	21
622+19		6.7					6.7	58.0	
622+38		6.7					6.7	58.0	
SUBTOTAL	0.0	66.9	0.0	0.0	0.0	133.3	200.2	876.0	53
SB TOTAL	568.4	1340.3	100.0	620.0	613.5	2360.6	5602.8	23606.0	1004
NB TOTAL	177.9	364.9	20.0	108.0	26.7	200.1	897.6	5280.0	80.0
*	74.63	170.52	12	72.8	64.02	256.07	650.04	2888.6	108.4
GRAND TOTAL	2696.7		932.8		3521.0		7150.4	31774.6	1192.4

* THIS CONTINGENCY QUANTITY OF 10% HAS BEEN ADDED FOR PAVEMENT DETERIORATION OVER THE WINTER SEASON.

APPROACH SLAB REPLACEMENT

LOCATION	APPROACH SLAB REM	PAV'T REM	BRIDGE APPROACH PAV'T	BRIDGE APPROACH PAV'T CONNECTOR (PCC)
STATION SO YD	SO YD	SO YD	SO YD	SO YD
SN 057-0167 (SOUTH)	53.3	42.7	133.3	26.7
SN 057-0167 (NORTH)	53.3	42.7	133.3	26.7
SN 057-0168 (SOUTH)	53.3	42.7	133.3	26.7
SN 057-0168 (NORTH)	53.3	42.7	133.3	26.7
SN 057-0169 (SOUTH)	53.3	42.7	133.3	26.7
SN 057-0169 (NORTH)	53.3	42.7	133.3	26.7
SN 057-0170 (NORTH)	53.3	42.7	133.3	26.7
TOTAL	373	299	933	187

PARTIAL DEPTH PATCHING

STATION	PARTIAL DEPTH REMOVAL, 2"		PARTIAL DEPTH PATCHING	
	PASS	DRIVE	PASS	DRIVE
	SO. YD.	SO. YD.	TONS	TONS
NORTH BOUND:				
160+75	0.7		0.1	
166+85		6.7		0.8
168+35		13.3		1.5
179+30		1.0		0.1
181+00		1.0		0.1
187+26	0.7		0.1	
190+75		4.4		0.5
195+30		0.7		0.1
220+95		0.7		0.1
222+00		1.0		0.1
226+62	4.4		0.5	
231+98		0.7		0.1
239+85	13.3		1.5	
247+65	6.7		0.8	
254+78		1.0		0.1
261+32		0.7		0.1
275+45		4.4		0.5
284+69	4.4		0.5	
290+21		13.3		1.5
300+46		16.7		1.9
302+12		0.7		0.1
310+53	0.7	1.0	0.1	0.1
325+13		16.7		1.9
340+65		4.4		0.5
352+94		1.0		0.1
361+87	1.0		0.1	
375+89		4.4		0.5
381+62		15.6		1.8
394+25		8.9		1.0
401+74	1.0		0.1	
415+62	0.7		0.1	
423+51		4.4		0.5
436+87		13.3		1.5
447+98		1.0		0.1
459+65	16.7		1.9	
467+84	4.4		0.5	
478+80		1.0		0.1
487+52		0.7		0.1
498+32		8.9		1.0
502+63	5.6		0.6	
523+97	5.6		0.6	
544+96		13.3		1.5
556+24	6.7		0.8	
578+65	6.7		0.8	
592+64	13.3		1.5	
603+63		5.6		0.6
616+85		6.7		0.8
624+75	1.0		0.1	
NB SUBTOTAL	93.6	173.2	10.7	19.7

PARTIAL DEPTH PATCHING (CONTINUED)

STATION	PARTIAL DEPTH REMOVAL, 2"		PARTIAL DEPTH PATCHING	
	PASS	DRIVE	PASS	DRIVE
	SO. YD.	SO. YD.	TONS	TONS
SOUTH BOUND:				
111+62		6.7		0.8
120+62		6.7		0.8
132+98	1.0	13.3	0.1	1.5
144+75	1.0		0.1	
158+69		16.7		1.9
169+45		2.2		0.3
180+52		3.3		0.4
195+97		2.2		0.3
202+32		1.1		0.1
210+74		6.7		0.8
224+95		4.4		0.5
238+76	6.7		0.8	
251+63		13.3		1.5
269+84	6.7		0.8	
278+95		8.9		1.0
290+64	5.6		0.6	
302+74	13.3		1.5	
315+69		16.7		1.9
329+64	8.9		1.0	
342+74	8.3	11.1	1.0	1.3
359+41		11.1		1.3
378+62		8.3		1.0
394+52		11.1		1.3
405+69	3.3	16.7	0.4	1.9
418+96	2.2	2.2	0.3	0.3
430+75		3.3		0.4
440+22	6.7	2.2	0.8	0.3
452+80		16.7		1.9
456+48	6.7		0.8	
464+88		44.4		5.2
470+00	5.6	5.6	0.6	0.6
481+40	13.3	13.3	1.5	1.5
487+30		17.8		2.1
489+41	8.9	8.9	1.0	1.0
493+56		11.1		1.3
496+07		17.8		2.1
497+81		15.6		1.8
504+05		11.1		1.3
519+31		11.1		1.3
521+65	8.3	8.3	1.0	1.0
526+59		11.1		1.3
531+93		16.7		1.9
532+22		2.2		0.3
533+29	3.3	3.3	0.4	0.4
534+77	2.2	2.2	0.3	0.3
537+64		1.1		0.1
576+63		6.7		0.8
579+12		4.4		0.5
585+00	8.3		1.0	
592+94	15.6		1.8	
593+78	13.3		1.5	
601+23		8.3		1.0
612+52		3.3		0.4
619+35		2.2		0.3
SB SUBTOTAL	149.8	411.4	17.3	48.0
NB SUBTOTAL	93.6	173.2	10.7	19.7
+10% *	24.34	58.46	2.8	6.77
GRAND TOTAL	910.8		105.3	

* THIS CONTINGENCY QUANTITY OF 10% HAS BEEN ADDED FOR PAVEMENT DETERIORATION OVER THE WINTER SEASON.

WOVEN WIRE FENCE		
LOCATION	WOVEN WIRE FENCE 4 FT	WOVEN WIRE FENCE REMOVAL
	FOOT	FOOT
NORTH BOUND		
110+00	40	40
136+40	40	40
183+92	10	10
210+32	15	15
236+72	10	10
306+88	10	10
370+47	10	10
412+71	30	30
470+28	20	20
496+68	10	10
517+80	45	45
533+64	10	10
SOUTH BOUND		
476+35	20	20
391+87	10	10
STRUCTURE NO:		
057-0162	50	50
057-0163	100	100
057-0164	100	100
057-0165	50	50
057-0166	50	50
057-0167	50	50
057-0168	50	50
057-0169	50	50
057-0170	50	50
TOTAL	830	830

CLASS D PATCHING, 10 IN.						
STATION	TYPE II		TYPE III		TYPE IV	
	PASS SO. YD.	DRV SO. YD.	PASS SO. YD.	DRV SO. YD.	PASS SO. YD.	DRV SO. YD.
SOUTHBOUND:						
53+52	8.0	8.0				
53+12		8.0				
52+86		8.0				
52+35				20.0		
52+03		13.3				
51+82						26.7
51+41				16.0		
51+20	8.0	8.0				
86+75			16.0			26.7
87+43	8.0	8.0				
87+98		10.7				
88+46	8.0					
89+14		13.3				
89+96				16.0		
91+03	8.0	8.0				
92+36		13.3				
92+87		8.0				
93+64						26.7
94+53	8.0	8.0				
95+23		13.3				
SUBTOTAL	48.0	127.9	16.0	52.0	0.0	88.1
+10% *	4.8	12.8	1.6	5.2	0.0	8.8
TOTAL	193.5		74.8			88.1

* THIS CONTINGENCY QUANTITY OF 10% HAS BEEN ADDED FOR PAVEMENT DETERIORATION OVER THE WINTER SEASON.

CLASS D PATCHING, 8 IN.			
STATION	TYPE II	TYPE III	TYPE IV
	SO. YD.	SO. YD.	SO. YD.
RAMP A:			
117+88	8.9		
118+56	8.9		
115+27	14.2		
116+02		17.8	
116+55	8.9		
118+33	8.9		
119+11			26.7
121+03	8.9		
122+68			26.7
124+35	8.9		
125+72	8.9		
126+01	8.9		
RAMP B:			
284+53	8.9		
285+76	8.9		
287+14		17.8	
288+63	8.9		
289+99			26.7
291+23	8.9		
292+87	8.9		
294+31		17.8	
RAMP C:			
355+01	8.9		
357+42	8.9		
359+04		17.8	
360+53	8.9		
361+87	8.9		
363+32			26.7
364+56		17.8	
365+74	8.9		
367+01	8.9		
368+25	8.9		
370+05	8.9		
RAMP D:			
447+00	8.9		
448+24		17.8	
450+76		17.8	
452+65			26.7
453+84	8.9		
455+02			26.7
456+00		17.8	
SUBTOTAL	218.9	142.4	160.2
+10% *	21.9	14.2	16.0
TOTAL	240.8	156.6	176.2

* THIS CONTINGENCY QUANTITY OF 10% HAS BEEN ADDED FOR PAVEMENT DETERIORATION OVER THE WINTER SEASON.

GUARDRAIL SCHEDULE							
LOCATION	GUARD-RAIL REM	REMOVE & REERECT SPBGR	TBT TY I SPECIAL TANGENT	TBT TY 6	GUARD-RAIL MARK	TERMINAL MARK DIR APPLIED	BARRIER WALL MARKERS
	FOOT	FOOT	EACH	EACH	EACH	EACH	EACH
SN 057-0162	504						
SN 057-0163	86.5	125	1	2	5	2	6
SN 057-0164	86.5	125	1	2	5	2	6
SN 057-0167	86.5	125	1	2	5	2	10
SN 057-0168	86.5	125	1	2	5	2	10
SN 057-0169	86.5	125	1	2	5	2	8
SN 057-0170	86.5	125	1	2	5	2	8
TOTAL	1023	750	6	12	30	12	48

TREE REMOVAL (6 TO 15 UNITS DIAMETER)	
LOCATION	UNIT
SN 057-0163 & 057-0164	52
SN 057-0167 & 057-0168	25
SN 057-0169 & 057-0170	6
TOTAL	83

SEEDING SCHEDULE						
LOCATION	EMBANK-MENT	SEEDING CLASS 2	NIT. FERT. NUT.	PHOS. FERT. NUT.	POT. FERT. NUT.	EROSION CONTROL BLANKET
	CU YD	ACRE	LB	LB	LB	SO YD
STA 110+00 (X-OVER)	8.8	0.020	1.80	1.80	1.80	97.8
STA 145+00	3.7	0.002	0.18	0.18	0.18	11.1
STA 199+75 (X-OVER)	8.8	0.020	1.80	1.80	1.80	97.8
STA 412+70 (X-OVER)	8.8	0.020	1.80	1.80	1.80	97.8
STA 425+00	3.7	0.002	0.18	0.18	0.18	11.1
STA 516+70	3.7	0.002	0.18	0.18	0.18	11.1
STA 614+75 (X-OVER)	8.8	0.020	1.80	1.80	1.80	97.8
STA 622+00	3.7	0.002	0.18	0.18	0.18	11.1
TOTAL	50	0.088	7.92	7.92	7.92	435.6

JAN. 11, 2000
VED02100-DETAILS.DWG

F.A.I. RTE.	SECTION	COUNTY	TOTAL SHEETS	SHEET NO.
55	*	MCLEAN	139	17
STA.	TO STA.			
FED. ROAD DIST. NO.	ILLINOIS FED. AID PROJECT			
* 157-3-1, 57-3, 57-3-2, 57-21 RS				

MAINLINE SCHEDULE

LOCATION	LENGTH	PAV'T AREA	BIT. CONC. SURF. CSE. SUPERPAVE	BIT. CONC. BIND CSE SUPERPAVE	BIT SHLDR	BIT SHLDR 10"	PAVED SHLDR REM	AGG SHLDS	BIT SURF REM (BUTT JT)	TEMP RAMP	BIT MAT (PR CT)	AGG (PR CT)	LEVEL BIND (HM)	MIX FOR CRACKS, JTS & FLGWYS	MEDIAN REM PART. DEPTH	PCC SURF REM (BUTT JT)
		SO YD	TON	TON	TON	SO YD	SO YD	TON	SO YD	SO YD	GALLON	TON	TON	TON	SO FT	SO YD
NORTHBOUND LANES:																
40+60 TO 39+00	160	640.0	55.7	65	53.6			13.2	405	240	51.2	1.3	0.3	0.2		
39+00 TO 36+03.18	296.82	1187.3	103.3	120.5	99.5			24.4			95	2.4	0.6	0.4		
98+45.54 TO 111+48.72	1303.18	5212.7	453.5	529.1	436.7			107.2			417	10.4	2.6	1.6		
111+48.72 TO 117+48.72	600	2000.0	174	203	201.1			49.4			160	4	1	0.6		
117+48.72 TO 322+00	20451.28	54536.7	4744.7	5535.5	6853.5	1530.0	1529.7	1682.2		107	4362.9	109.1	27.3	16.4		
322+00 TO 323+89	STRUCTURE NUMBER 057-0164															
323+89 TO 586+74	26285	70093.3	6098.1	7114.5	8808.4	2111.0	2173.7	2162		213	5607.5	140.2	35	21		
586+74 TO 590+01	STRUCTURE NUMBER 057-0168															
590+01 TO 606+63	1662	4432.0	385.6	449.8	557.0	2072.0	2170.7	136.7		213	354.6	8.9	2.2	1.3		
606+63 TO 610+08	STRUCTURE NUMBER 057-0170															
610+08 TO 625+00	1492	3978.7	346.1	403.8	500.0	576.0	640.0	122.7		107	318.3	8	2	1.2		
625+00 TO 626+30	130	346.7	30.2	35.2	43.6			10.7	89	133	27.7	0.7	0	0.1		133
SOUTHBOUND LANES:																
55+35 TO 53+75	160	426.7	37.1	43.3	46.9			13.2	296	160	34.1	0.9	0.2	0.1		
53+75 TO 51+14.53	260.47	1884.2	163.9	191.2	87.3			21.4	311	160	150.7	3.8	0.9	0.9	411	
86+60.28 TO 89+87.56	327.28	1967.5	171.2	199.7	109.7			26.9			157.4	3.9	1	0.6	2161	
89+87.56 TO 97+25	737.44	3523.3	306.5	357.6	247.1			60.7			281.9	7	1.8	1.1		
97+25 TO 120+60.28	2335.28	9341.1	812.7	948.1	782.6			192.1			747.3	18.7	4.7	2.8		
120+60.28 TO 126+60.28	600	2000.0	174	203	201.1			49.4			160	4	1	0.6		
126+60.28 TO 322+00	19539.72	52105.9	4533.2	5288.7	6548.0	1530.0	1529.7	1607.2		107	4168.5	104.2	26.1	15.6		
322+00 TO 323+89	STRUCTURE NUMBER 057-0163															
323+89 TO 586+74	26285	70093.3	6098.1	7114.5	8808.4	2108.0	2171.9	2162		213	5607.5	140.2	35	21		
586+74 TO 590+01	STRUCTURE NUMBER 057-0167															
590+01 TO 606+63	1662	4432.0	385.6	449.8	557.0	2047.0	2171.1	136.7		213	354.6	8.9	2.2	1.3		
606+63 TO 610+08	STRUCTURE NUMBER 057-0169															
610+08 TO 625+00	1492	3978.7	346.1	403.8	500.0	576.0	640.4	122.7		107	318.3	8	2	1.2		
625+00 TO 626+30	130	346.7	30.2	35.2	43.6			10.7	89	133	27.7	0.7	0.2	0.1		133
MAINT. CROSSOVERS:																
110+00		171.1	14.9	17.4							64.2					
199+75		171.1	14.9	17.4							64.2					
412+70		171.1	14.9	17.4							64.2					
614+75		171.1	14.9	17.4							64.2					
RAMPS:																
RAMP A	2636	7283.0	633.6	739.2	552.1			433.6	56	461	582.6	14.6	3.6	2.2		461
RAMP B	1685	5347.0	465.2	542.7	352.9			277.2	56	450	427.8	10.7	2.7	1.6		450
RAMP C	2540	7378.0	641.9	748.9	532.0			417.8	56	333	590.2	14.8	3.7	2.2		333
RAMP D	1690	5334.0	464.1	541.4	354.0			278.0	56	442	426.7	10.7	2.7	1.6		442
					1000.0	1000.0	1000.0									
TOTAL	114460.5	318553.2	27714.2	32333.1	38276.1	13550.0	14027.2	10118.1	1414.0	3792.0	25686.3	636.1	158.8	95.7	2572.0	1952.0

*CONTINGENCY QUANTITY ADDED FOR DETERIORATION AND LOW SHOULDER AREAS

JAN. 11. 2000
VE002100.DETA1LS.DGN

F.A.I. RTE.	SECTION	COUNTY	TOTAL SHEETS	SHEET NO.
55	•	MCLEAN	139	18
STA.	TO STA.			
FED. ROAD DIST. NO.	ILLINOIS	FED. AID PROJECT		
* (57-3-L, 57-3, 57-3-2, 57-2) R5				

MAINLINE DRAINAGE															
LOCATION	PRC FLARED	PRC FLARED	PIPE CULVERT	PIPE CULVERT	TRENCH BACK	AGG BASE	INLET BOX	STONE DUMPED	FILTER FABRIC	CLEAN EXIST	PIPE CULV	END SECT	REM INLETS	INLET TO BE	PAVED DITCH
	END SEC	END SEC	CL A, TY	CL A, TY	FILL	CSE	STD.	RIP RAP	USE W/	INLET	REM	REM	EACH	ADJUST	BREAKINGS
	24"	36"	24"	36"	CU YD	TY-A	542526	CL. A4	RIP RAP	EACH	FOOT	EACH	EACH	EACH	SO FT
51+25 (MEDIAN)														1	
127+00 (S.B.)								8	11.1						
136+00 (S.B.)	1		15								15	1			
158+55 (MEDIAN)										2					
168+00 (MEDIAN)										1					
189+00 LT. (MEDIAN)										1					
199+00 (N.B.)								8	11.1						
209+00 (S.B.)								8	11.1						
216+00 (N.B.)								8	11.1						
225+00 (MEDIAN)										1					
268+75 (MEDIAN)										1					
341+00 (S.B.)								8	11.1						
364+00 (S.B.)								8	11.1						
392+30 (MEDIAN)										1					
436+57 (S.B.)			1								20	1			
496+75 (MEDIAN)										1					
542+00 (S.B.)	1		15								15	1			
564+00 (S.B.)								8	11.1						
573+00 (S.B.)								8	11.1						
614+75 (MEDIAN)					40						40		2		
SN 057-0164 (SE QUAD)								22	33						11.1
SN 057-0801 (EAST)								135	131						44.4
TOTAL	2	1	70	20	5	6	2	221	252.8	8	90	3	2	1	55.5

CLASS B PATCHING, 10 IN.											
STATION	TYPE II		TYPE III		TYPE IV		PAVT FABRIC	SAW CUT	TIE BARS	DOWEL BARS	1 1/2"
	PASS	DRV	PASS	DRV	PASS	DRV					
	SQ. YD.	SQ. YD.	SQ. YD.	SQ. YD.	SQ. YD.	SQ. YD.					
SOUTHBOUND:											
53+52	0.0	0.0						96			40
53+12	0.0	0.0						48			20
52+00		0.0						48			20
52+35				20.0			20.0	66			20
52+03		13.3						56			20
51+02						26.7	26.7	78	11		20
51+41				18.0			16.0	60			20
51+20	0.0	0.0						96			40
06+75			10.0			26.7	42.7	136			40
07+43	0.0	0.0						96	11		40
07+98		10.7						52			20
00+46	0.0							48			20
09+14		13.3						56			20
09+06				16.0			16.0	60			20
01+03	0.0	0.0						96			40
02+36		13.3						56			20
02+07		0.0						48			20
03+64						26.7	26.7	78	11		20
04+52	0.0	0.0						96			40
05+23		13.3						56			20
SUBTOTAL	48.0	127.9	16.0	52.0	0.0	80.1	148.1	1422.0	33.0		520.0
	4.8	12.8	1.6	5.2	0.0	8.0	14.0	142.2	3.3		52.0
TOTAL	193.5	74.8	88.1				162.9	1564.0	36.0		572.0

* A CONTINGENCY QUANTITY OF 10% HAS BEEN ADDED FOR PAVEMENT DETERIORATION OVER THE WINTER SEASON.

PAVEMENT MARKINGS																			
LOCATION	LENGTH	THERMOPLASTIC PAVEMENT MARKING					TEMPORARY PAVEMENT MARKING				SHORT TERM PAVEMENT MARKING	WORK ZONE PAVT. MARKING REMOVAL	RAISED REFL. PAVT MARK REMOVAL	RAISED REFLEC. PAVT MARKERS		PRISMATIC CURB REFLECT	DELIN. REM.	DELIN.	
		4 IN		6 IN	8 IN	18 IN	4 IN		6 IN	8 IN				CRYSTAL	AMBER				
		WHITE	YELLOW	WHITE	WHITE	WHITE	WHITE	YELLOW	WHITE	WHITE									
	FOOT	FOOT	FOOT	FOOT	FOOT	FOOT	FOOT	FOOT	FOOT	FOOT	FOOT	SO FT	EACH	EACH	EACH	EACH	EACH		
NORTHBOUND LANES:																			
STA. 40+60 TO STA. 36+03.18	456.82	457	457	229			457	457	229			182	30	24	24		2	2	
STA. 98+45.54 TO STA. 111+48.72	1303.18	1303	1303	652			1303	1303	652			522	87	66	66		4	4	
STA. 111+48.72 TO STA. 626+30	51481.28	51481	51481	12870		24	51481	51481	12870			10296	1716	1287	1287		129	129	
RAMP D		1074	957		764		1074	957		764				75	59	16	28	28	
RAMP C		1573	1646		600		1573	1646		600							38	38	
SOUTHBOUND LANES:																			
STA. 55+35 TO STA. 51+14.53	420.47	420	420	170	520		420	420	170	520		136	22	31	31		2	2	
STA. 86+60.28 TO STA. 89+87.56	327.28	327	327	164	654		327	327	164	654		131	22	49	49		1	1	
STA. 89+87.56 TO STA. 120+60.28	3072.72	3073	3073	1537			3073	3073	1537			1229	205	154	154		8	8	
STA. 120+60.28 TO STA. 626+30	50569.72	50570	50570	12643		24	50570	50570	12643			10114	1686	1264	1264		126	126	
RAMP A		1312	1274		800		1312	1274		800				78	59	19	38	38	
RAMP B		975	915		800		975	915		800							28	28	
SN 057- 0162		3080	3080				3080	3080				2879				1160			
SN 057- 0165		1120	1120				1120	1120											
SN 057- 0166		570	570				570	570											
SUBTOTAL		117335	117193	28265	4138	48	117335	117193	28265	4138		22610	6647	3028	2993	35	1160	404	404
TOTAL		234528	234528	28265	4138	48	234528	234528	28265	4138		22610	6647	3028	3028		1160	404	404

CONCRETE HEADWALL							
SOUTHBOUND LANE				NORTHBOUND LANE			
LEFT SIDE		RIGHT SIDE		LEFT SIDE		RIGHT SIDE	
OUTLET STATION	CONCRETE HEADWALL FOR PIPE DRAIN EACH	OUTLET STATION	CONCRETE HEADWALL FOR PIPE DRAIN EACH	OUTLET STATION	CONCRETE HEADWALL FOR PIPE DRAIN EACH	OUTLET STATION	CONCRETE HEADWALL FOR PIPE DRAIN EACH
90+00	1	52+14	1	100+00	1	100+00	1
95+00	1	95+00	1	105+00	1	105+00	1
100+00	1	100+00	1	109+60	1	109+65	1
105+00	1	105+00	1	110+15	1	110+15	1
109+90	1	109+80	1	115+00	1	115+00	1
110+10	1	110+20	1	122+00	1	122+00	1
115+00	1	115+00	1	126+85	1	126+95	1
122+00	1	122+00	1	131+00	1	131+00	1
126+95	1	126+85	1	135+90	1	135+95	1
131+00	1	131+00	1	141+00	1	141+00	1
135+95	1	135+90	1	145+00	1	145+00	1
141+00	1	141+00	1	150+00	1	150+00	1
145+00	1	145+00	1	154+00	1	154+00	1
150+00	1	150+00	1	158+35	1	158+35	1
154+00	1	154+00	1	158+75	1	158+75	1
158+50	1	158+35	1	163+00	1	163+00	1
158+60	1	158+75	1	168+20	1	168+05	1
163+00	1	163+00	1	173+00	1	173+00	1
168+05	1	168+20	1	183+00	1	183+00	1
173+00	1	173+00	1	188+80	1	188+06	1
183+00	1	183+00	1	192+00	1	192+00	1
188+95	1	188+80	1	197+00	1	197+00	1
192+00	1	192+00	1	198+82	1	199+00	1
197+00	1	197+00	1	204+00	1	204+00	1
198+94	1	198+82	1	209+00	1	209+00	1
198+94	1	204+00	1	212+00	1	212+00	1
204+00	1	208+94	1	216+00	1	216+00	1
208+94	1	212+00	1	220+00	1	220+00	1
212+00	1	216+00	1	220+00	1	224+94	1
212+00	1	220+00	1	224+94	1	224+94	1
216+00	1	220+00	1	228+00	1	228+00	1
220+00	1	225+00	1	228+00	1	228+00	1
220+00	1	225+00	1	230+00	1	230+00	1
225+00	1	228+00	1	235+00	1	235+00	1
225+00	1	230+00	1	239+00	1	235+00	1
228+00	1	235+00	1	241+94	1	239+00	1
230+00	1	239+00	1	247+00	1	241+94	1
235+00	1	244+00	1	250+00	1	246+82.48	1
239+00	1	248+00	1	250+00	1	246+82.48	1
244+00	1	250+00	1	252+50	1	250+00	1
248+97.13	1	250+00	1	252+50	1	250+00	1
252+00	1	252+54	1	256+00	1	251+90	1
252+00	1	256+00	1	262+00	1	256+00	1
253+00	1	262+00	1	265+00	1	262+00	1
253+00	1	265+00	1	268+75	1	265+00	1
256+00	1	268+68	1	268+75	1	267+00	1
262+00	1	268+82	1	271+00	1	267+00	1
265+00	1	271+00	1	277+50	1	272+00	1
268+68	1	277+50	1	281+00	1	275+00	1
268+82	1	281+00	1	284+00	1	278+00	1
271+88.28	1	284+00	1	289+00	1	281+00	1
SUBTOTAL	51		51		51		51

CONCRETE HEADWALL							
SOUTHBOUND LANE				NORTHBOUND LANE			
LEFT SIDE		RIGHT SIDE		LEFT SIDE		RIGHT SIDE	
OUTLET STATION	CONCRETE HEADWALL FOR PIPE DRAIN EACH	OUTLET STATION	CONCRETE HEADWALL FOR PIPE DRAIN EACH	OUTLET STATION	CONCRETE HEADWALL FOR PIPE DRAIN EACH	OUTLET STATION	CONCRETE HEADWALL FOR PIPE DRAIN EACH
275+00	1	289+00	1	293+98	1	284+00	1
281+00	1	294+00	1	298+00	1	289+00	1
284+00	1	299+00	1	302+00	1	293+98	1
287+00	1	304+00	1	305+98	1	298+00	1
294+00	1	309+00	1	305+98	1	302+00	1
299+00	1	314+00	1	311+00	1	305+98	1
304+00	1	318+98	1	316+00	1	311+00	1
309+00	1	321+30	1	319+00	1	316+00	1
314+00	1	321+30	1	321+90	1	319+00	1
318+98	1	327+00	1	321+90	1	321+90	1
321+30	1	327+00	1	326+98	1	321+90	1
321+30	1	329+00	1	327+02	1	326+98	1
327+00	1	333+00	1	327+02	1	327+02	1
327+00	1	337+00	1	332+00	1	327+02	1
329+00	1	341+20	1	337+00	1	332+00	1
333+00	1	341+20	1	341+20	1	337+00	1
337+00	1	344+00	1	341+20	1	341+06	1
341+06	1	350+00	1	344+00	1	344+00	1
344+00	1	352+00	1	350+00	1	350+00	1
350+00	1	354+04	1	352+00	1	352+00	1
352+00	1	354+04	1	354+04	1	354+25	1
354+25	1	354+46	1	354+04	1	354+25	1
354+25	1	357+00	1	354+46	1	357+00	1
357+00	1	360+00	1	354+46	1	360+00	1
360+00	1	360+00	1	357+00	1	360+00	1
360+00	1	364+02	1	360+00	1	364+00	1
364+02	1	369+00	1	360+00	1	369+00	1
369+00	1	369+00	1	364+00	1	374+00	1
374+00	1	374+00	1	369+00	1	380+00	1
380+00	1	380+00	1	369+00	1	380+00	1
383+94	1	383+94	1	374+00	1	380+00	1
383+94	1	388+00	1	380+00	1	384+00	1
388+00	1	391+50	1	384+00	1	388+00	1
391+50	1			388+00	1	391+50	1
				391+50	1		
RAMP A				RAMP C			
117+00	1	117+00	1	358+50	1	358+50	1
121+00	1	121+00	1	362+00	1	362+00	1
124+00	1	124+00	1	367+00	1	366+50	1
125+00	1	128+03	1	367+00	1	369+75	1
125+00	1	128+03	1			369+75	1
RAMP B				RAMP D			
297+00	1	295+11	1	449+00	1	446+83	1
287+00	1	285+11	1	449+00	1	446+83	1
291+00	1	287+78	1	451+00	1	451+00	1
		291+00	1	453+50	1	453+50	1
SUB TOTAL	42		42		43		43
GRAND TOTAL =			374				

NOTE: THESE LOCATIONS SHOULD SERVE ONLY AS A GUIDE FOR LOCATING THE EXISTING PIPE UNDERDRAIN OUTLETS. THE LOCATIONS WERE TAKEN FROM EXISTING PLANS AND WERE NOT FIELD VERIFIED.

DATE: 11/15/07

F.A.I. RYE.	SECTION	COUNTY	TOTAL SHEETS	SHEET NO.
55	♦	MCLEAN	139	22
STA.	TO STA.			
FED. ROAD DIST. NO.	ILLINOIS	FED. AID PROJECT		
■ 157-3-1, 57-3, 57-3-2, 57-21 RS				

QC/QA BITUMINOUS	
PAY ITEM	TONS
BIT. CONC. SURF. CSE., SUPERPAVE	27978
BIT. CONC. BIND. CSE., SUPERPAVE	32377
BIT. BASE CSE., 8"	1174
BIT. SHOULDERS, 10"	7859
BIT. SHOULDERS	38276
PARTIAL DEPTH PATCHES	105
SHOULDERS REMOVE AND REPLACE	9524
TOTAL	117,293

PAVEMENT REPAIR S.N. 057-0166					
LOCATION	PAV'T REM SO. YD.	CONTROLLED LOW STRENGTH MATERIAL CU. YD.	AGG. BASE CSE TYPE A TON	BIT. CONC. SURF. CSE. SUPERPAVE TON	BIT. CONC. BINDER CSE. SUPERPAVE TON
NE QUADRANT	2.2	1	0.9	0.2	0.2
SE QUADRANT	2.2	1	0.9	0.2	0.2
TOTAL	4.4	2	1.8	0.4	0.4

QC/QA PORTLAND CEMENT CONCRETE	
PAY ITEM	CU YD
CCC & G, TYPE M-6.06	22
PC CONC. BASE CSE. 8"	13
BRIDGE APPROACH PAV'T	259
BRIDGE APPROACH PAV'T CONNECTOR (PCC)	52
CLASS A PATCHES	1788
CONCRETE SUPERSTRUCTURE	87
SLOPEWALL 6"	5
CONC. HEADWALL FOR PIPEDRAINS	76
CONCRETE MEDIAN SURFACE, 4"	47
PCC RAMPED MEDIAN TERMINAL	1
BRIDGE DECK MICROSILICA CONCRETE OVERLAY	544
CLASS B PATCHES	237
TOTAL	3131

STAGING SCHEDULE						
LOCATION	TEMP. CONC. BARRIER FOOT	RELOC. TEMP. CONCRETE BARRIER FOOT	TEMP. CONC. BARRIER TERMINAL EACH	PAVT. MARK. TAPE TY. III 4" FOOT	PAV'T. MARK. REMOVAL SO. FT.	WORKZONE PAV'T. MARK. REMOVAL SO. FT.
SN 057-0162				8637	155	2879
SN 057-0163	590	597	1		97.5	
SN 057-0164	590	597	1		97.5	
SN 057-0165					40	
SN 057-0166					40	
SN 057-0167	680	687	1		97.5	
SN 057-0168	680	687	1		97.5	
SN 057-0169	650	657	1		97.5	
SN 057-0170	650	657	1		97.5	
TOTAL	3840	3882	6	8637	820	2879

S.N. 057-0162 /STAGE CONSTRUCTION													
LOCATION	CCC&G REM. FOOT	CCC&G FOOT	CONC. MEDIAN SURF. REM. SO. FT.	PCC RAMPED MEDIAN TERMINAL EA	CONC. MEDIAN SURF., 4" SO. FT.	P. C. C. BASE CSE. 8" SO. YD.	SUB-BASE GRAN. MAT. TY. A - 4" SO. YD.	AGG. BASE CSE. TY. A TON	PAV'T. REM. SO. YD.	BIT. BASE CSE. 8" SO. YD.	BIT. CONC. SURF. CSE. TON	BIT. CONC. BINDER CSE. TON	PAVED SHLDR REM SO. YD.
41+50 TO 43+10										178	15.5		178
43+47 TO 43+63	37		106	1		5	3						
44+21 TO 44+80	121	83	227	1	145	25	14			1072	93.3		1072
43+70 TO 48+52.5								117	273		24.0	24	
46+20 TO 48+25	410	410	2050		2050					1061	92.3		1061
51+47.5 TO 56+25								94	218		19.0		
52+00 TO 54+60	520	520	1440		1440								
55+20 TO 55+79	121	83	227	1	145	25	14						
56+37 TO 56+54	37		106	1		5	3			218	19.0		218
56+85 TO 58+81								211	491	2529	263	43	2529
TOTAL	1246	1096	4156	4	3780	60	34						

JAN 11 2008 11:00 AM TALLS.DGN

P.A.L. NO.	SECTION	COUNTY	TOTAL SHEETS	SHEET NO.
55	8	McLEAH	139	23
STA. 57+00		TO STA. 110+00		
P.O. NO. 001.00		SHEET NO.		P.O. NO. PROJECT
* 157-3-1,57-3,57-3-2,57-21RS				

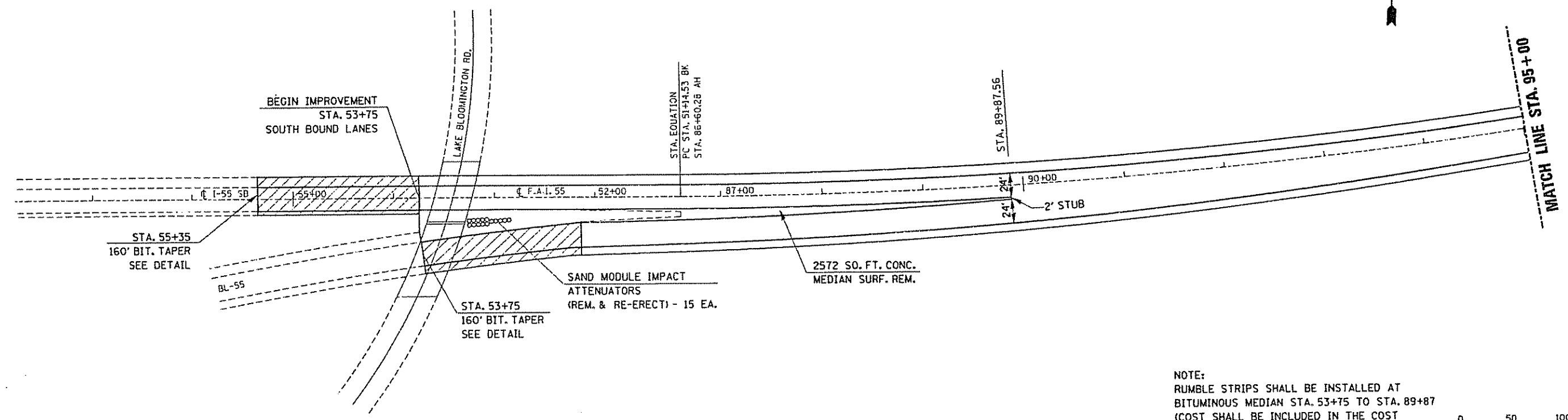

NOTE:
RUMBLE STRIPS SHALL BE INSTALLED AT BITUMINOUS MEDIAN STA. 53+75 TO STA. 89+87 (COST SHALL BE INCLUDED IN THE COST OF BIT. SURF. CSE.)

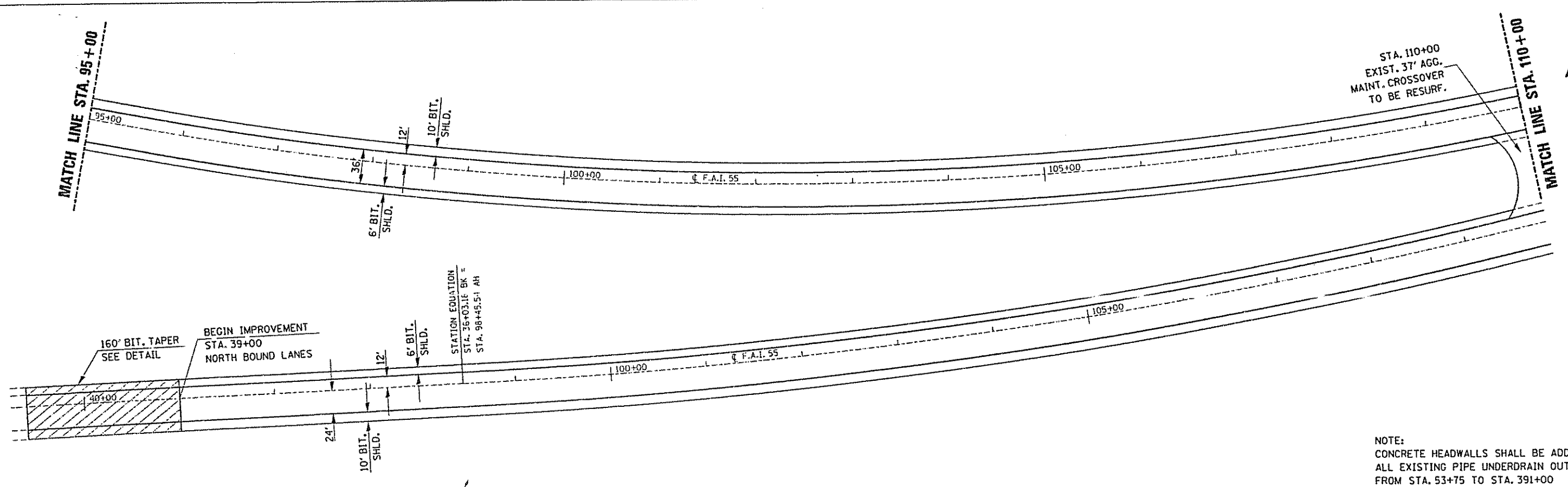

NOTE:
CONCRETE HEADWALLS SHALL BE ADDED TO ALL EXISTING PIPE UNDERDRAIN OUTLETS FROM STA. 53+75 TO STA. 391+00

STA. 57+00 TO STA. 110+00

JAN. 11, 2000
VEICOR1004SHEETS.DWG

P.L. NO.	SECTION	COUNTY	TOTAL SHEETS	SHEET NO.
55		McLEAN	134	24
STA. 110+00		TO STA. 140+00		
P.L. SHEET NO.		BLANKS	P.L. SHEET PROJECT	
157-3-157-3.57-3-2.57-2RS				

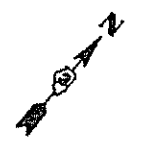
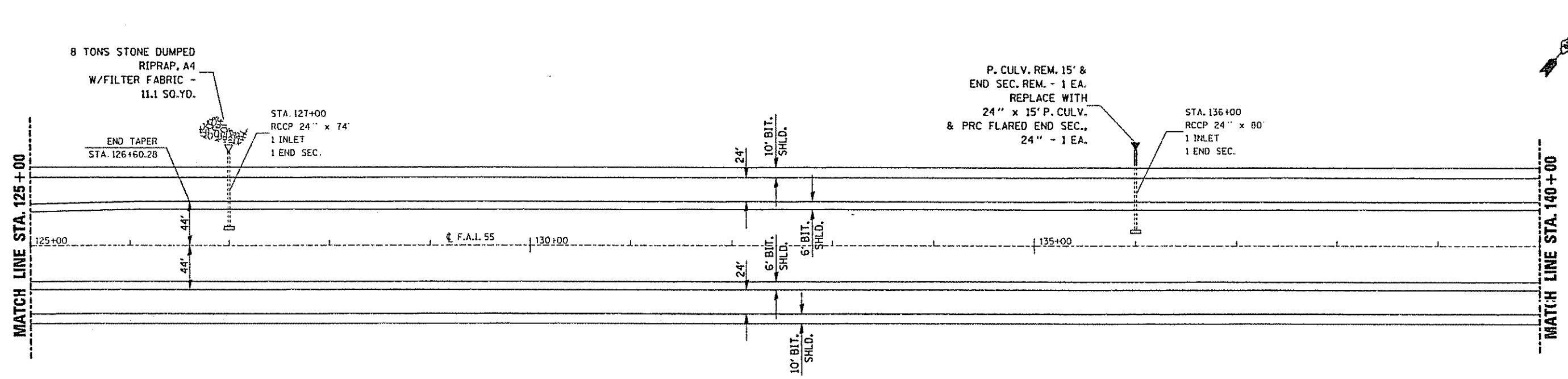
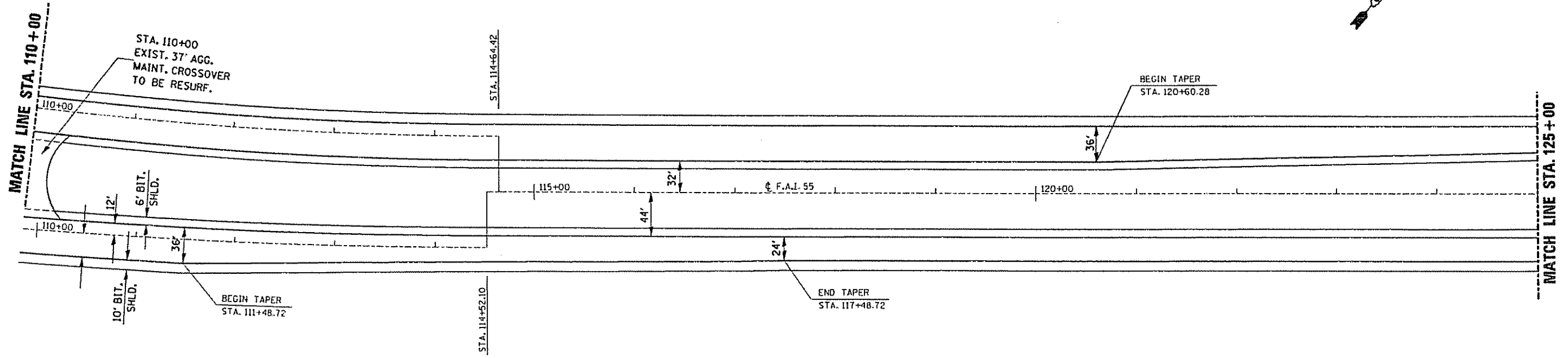
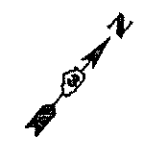

NOTE:
 CONCRETE HEADWALLS SHALL BE ADDED TO
 ALL EXISTING PIPE UNDERDRAIN OUTLETS
 FROM STA. 53+75 TO STA. 391+00

STA. 110+00 TO STA. 140+00

P.L. & S.P. NO.	SECTION	COUNTY	TOTAL SHEETS	SHEET NO.
55	8	McLEAN	129	25
STA. 140+00		TO STA. 170+00		
FIELD NO. & ETL. NO.		DATE	FIELD NO. PROJECT	
157-3-1.57-3.57-3-2.57-2IRS				

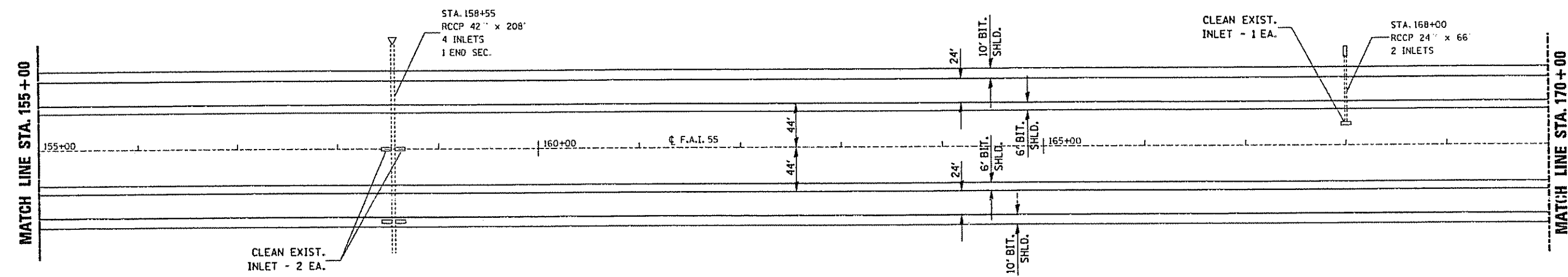
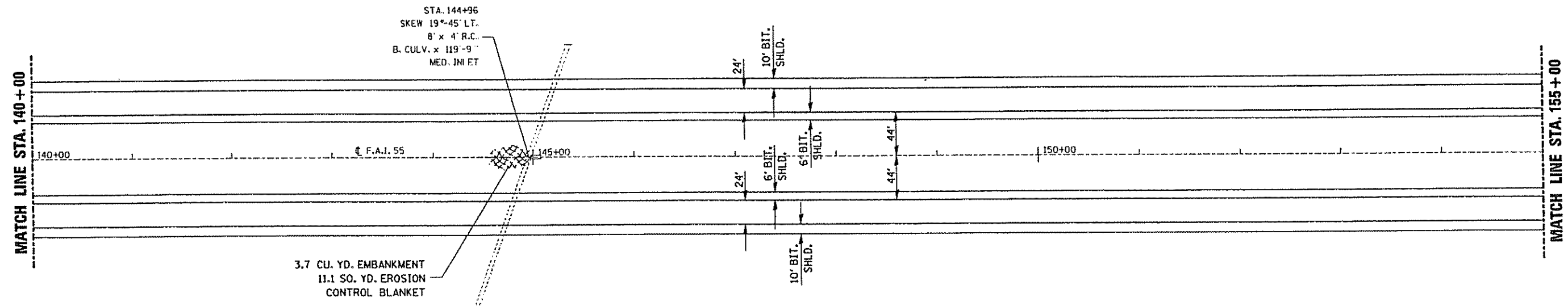
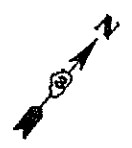

NOTE:
CONCRETE HEADWALLS SHALL BE ADDED TO ALL EXISTING PIPE UNDERDRAIN OUTLETS FROM STA. 53+75 TO STA. 391+00

STA. 140+00 TO STA. 170+00

JAN. 11, 2000
VED02100\SHEETS.DGN

P.A.L. NO.	SECTION	COUNTY	TOTAL SHEETS	SHEET NO.
55	*	MCLEAN	139	26
STA. 170+00		TO STA. 200+00		
P.L. ROAD DIST. NO.	BL. NO.	P.L. ROAD PROJECT		
*157-3-1.57-3.57-3-2.57-2RS				

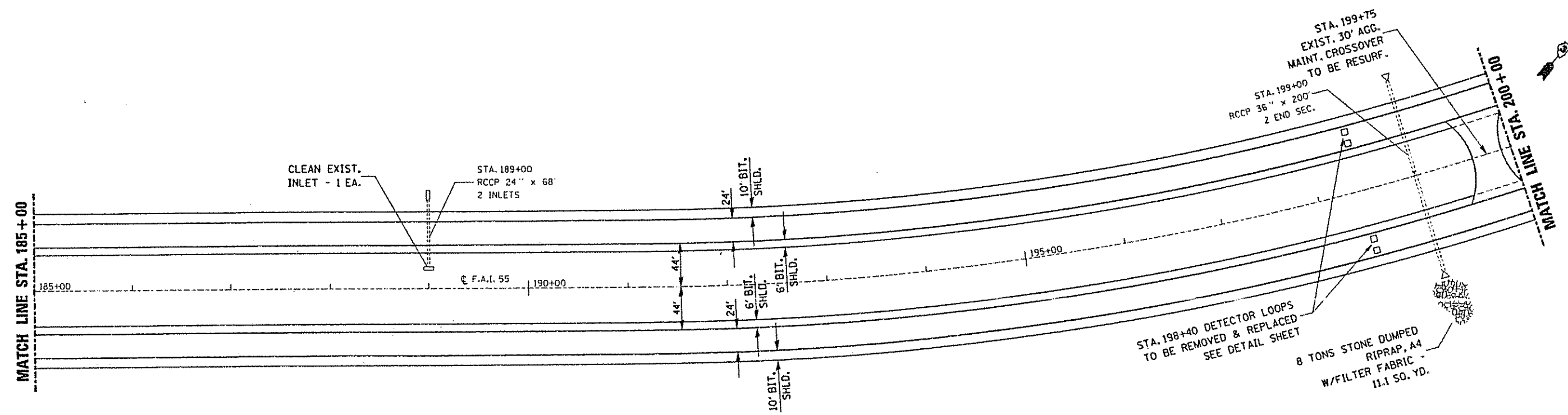
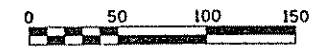
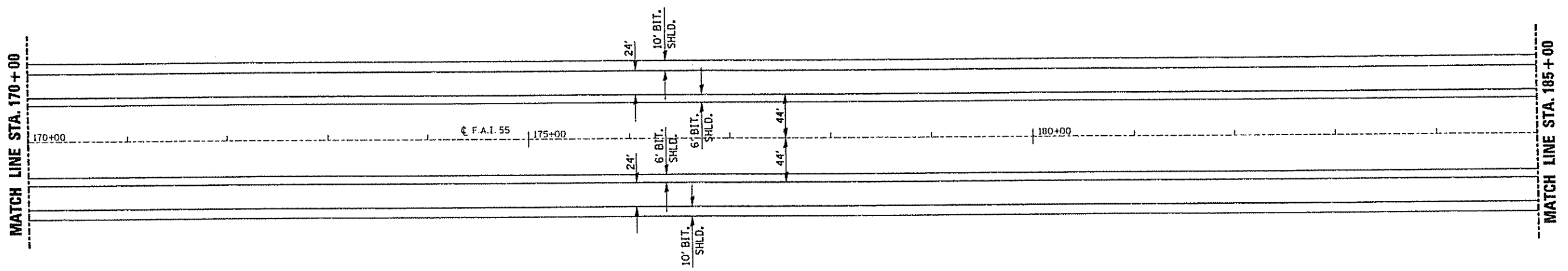
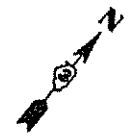

STA. 199+75
EXIST. 30' AGG.
MAINT. CROSSOVER
TO BE RESURF.

STA. 199+00
RCCP 36" x 200'
2 END SEC.

STA. 198+40 DETECTOR LOOPS
TO BE REMOVED & REPLACED
SEE DETAIL SHEET

8 TONS STONE DUMPED
RIPRAP, A4
W/FILTER FABRIC -
11.1 SQ. YD.

NOTE:
CONCRETE HEADWALLS SHALL BE ADDED TO
ALL EXISTING PIPE UNDERDRAIN OUTLETS
FROM STA. 53+75 TO STA. 391+00

STA. 170+00 TO STA. 200+00

P.L. & S.	SECTION	COUNTY	SHEET NO.	TOTAL SHEETS
55		MCLEAN	139	27
STA. 200+00		TO STA. 230+00		
P.L. AND S.V.L. NO.		BLK. NO.	P.L. AND PROJECT	
* 157-3-1.57-3.57-3-2.57-2HS				

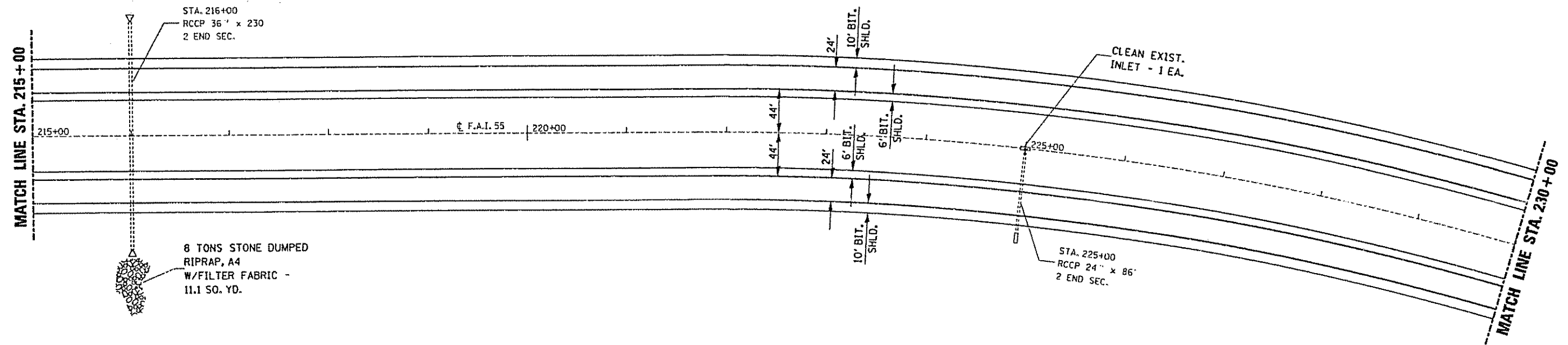
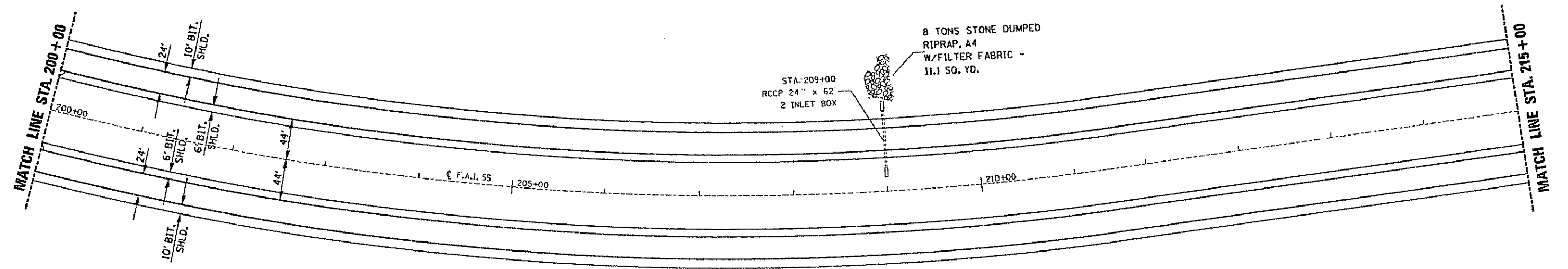

NOTE:
 CONCRETE HEADWALLS SHALL BE ADDED TO
 ALL EXISTING PIPE UNDERDRAIN OUTLETS
 FROM STA. 53+75 TO STA. 391+00

STA. 200+00 TO STA. 230+00

JAN. 11, 2000
 \ED02100\SHEETS.DGN

F.A.L. NO.	SECTION	COUNTY	TYPICAL SHEETS	SHEET NO.
55		McLEAN	139	28
STA. 230+00		TO STA. 260+00		
FED. ROAD DIST. NO.	ALIGNED	PUL. ROAD PROJECT		
*157-3-1,57-3,57-3-2,57-2HS				

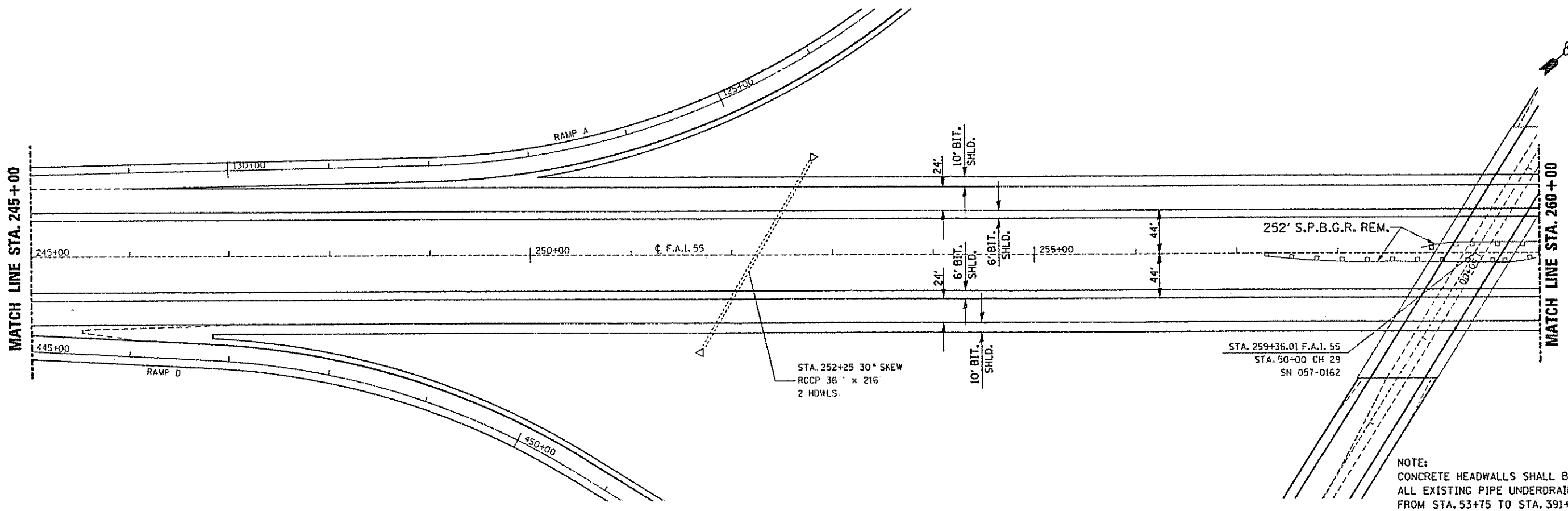
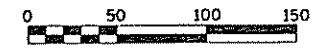
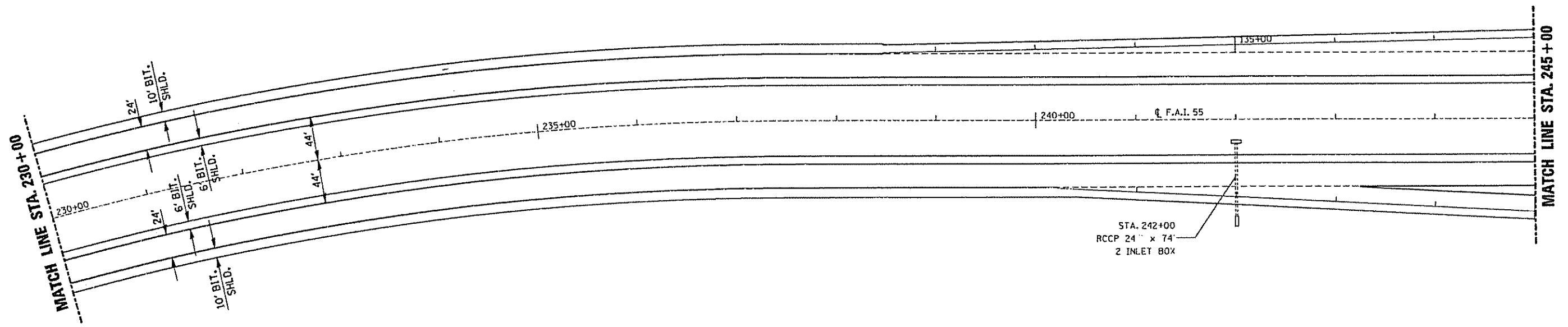
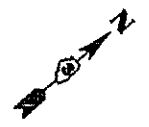

NOTE:
CONCRETE HEADWALLS SHALL BE ADDED TO ALL EXISTING PIPE UNDERDRAIN OUTLETS FROM STA. 53+75 TO STA. 391+00

STA. 230+00 TO STA. 260+00

11, 2000
00V SHEETS.DGN

P.A.L. NO.	SECTION	COUNTY	DATE	SHEET NO.
55		MGLEAN	139	29
STA. 260+00		TO STA. 290+00		
P.L. ROAD DIST. NO.	ILLINOIS	P.L. NO. PROJECT		
* 157-3-1.57-3.57-3-2.57-2R5				

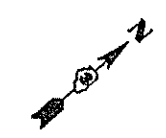
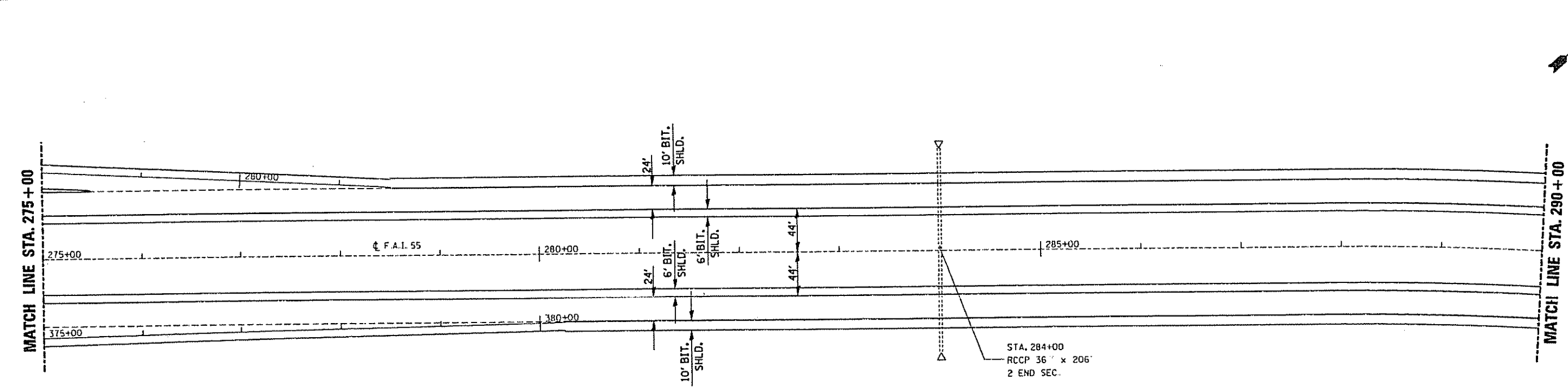
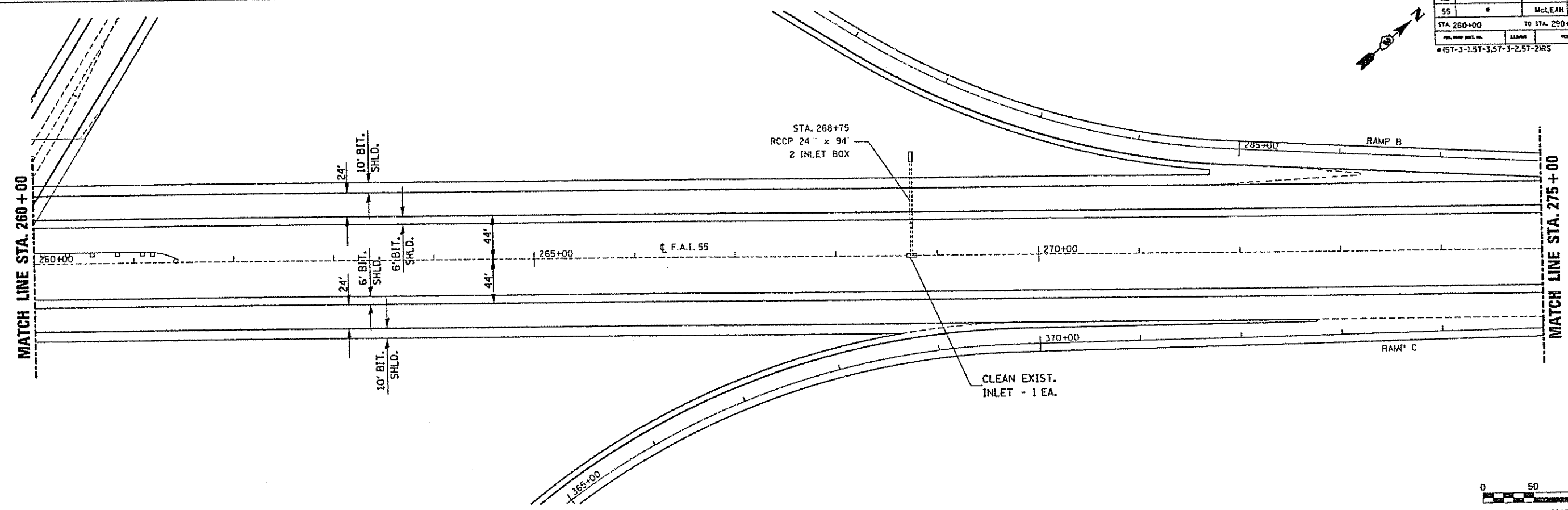

NOTE:
 CONCRETE HEADWALLS SHALL BE ADDED TO
 ALL EXISTING PIPE UNDERDRAIN OUTLETS
 FROM STA. 53+75 TO STA. 391+00

STA. 260+00 TO STA. 290+00

JAN. 11, 2000
 \ED02100\5SHEETS\00N

P.L. & P.M.	SECTION	COUNTY	TOTAL SHEETS	SHEET NO.
55	*	McLEAN	139	36
STA. 290+00		TO STA. 320+00		
P.L. FROM DIST. NO.		BLK. NO.	P.L. AND PROJECT	
* 157-3-1,57-3,57-3-2,57-2IRS				

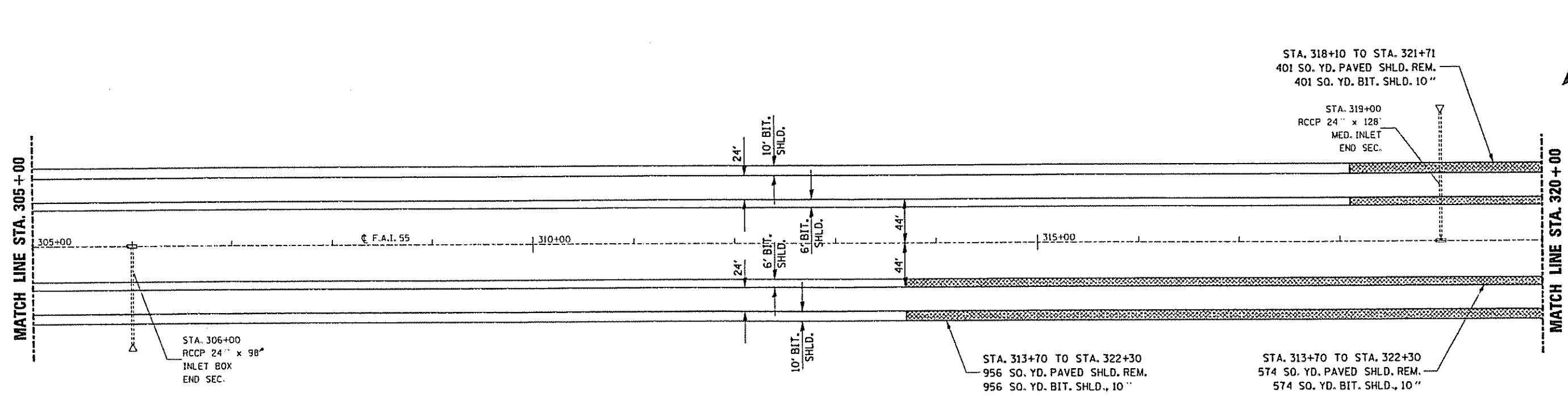
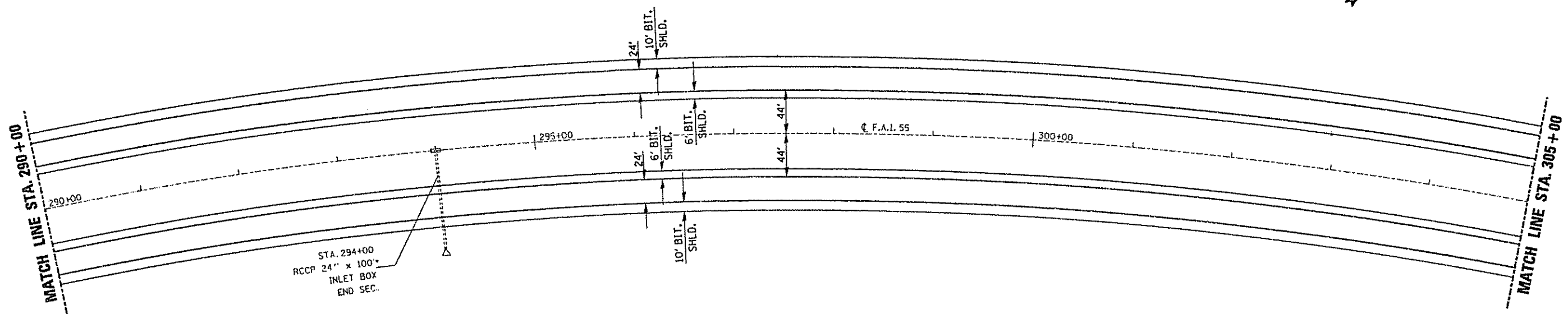

NOTE:
CONCRETE HEADWALLS SHALL BE ADDED TO
ALL EXISTING PIPE UNDERDRAIN OUTLETS
FROM STA. 53+75 TO STA. 391+00

STA. 290+00 TO STA. 320+00

JAN. 11, 2000
VED02100\SHEETS.DGN

P.A.L. NO.	SECTION	COUNTY	TOWN	SHEET
55	6	McLEAN	139	31
STA. 320+00		TO STA. 350+00		
PROJ. NAME	EST. NO.	SECTION	P.L. AND PROJECT	
* 157-3-1,57-3,57-3-2,57-2,1RS				

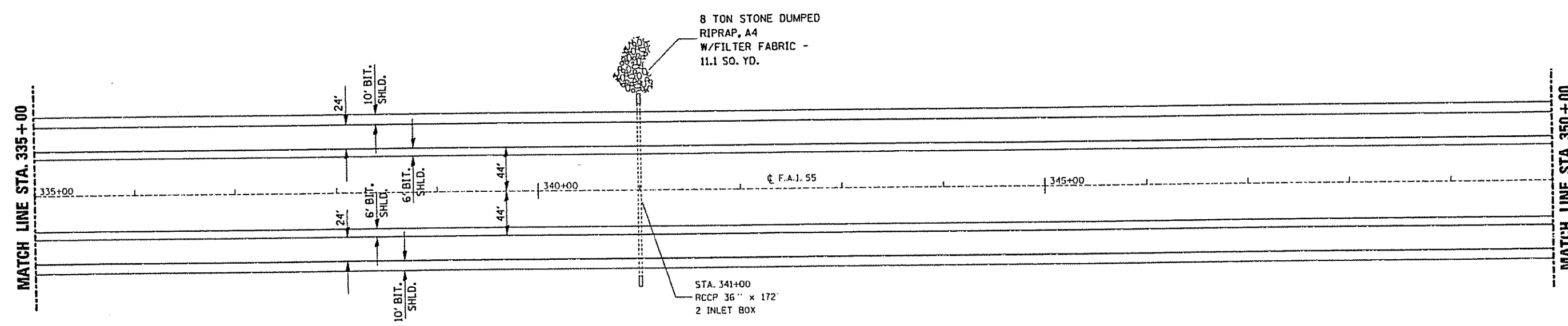
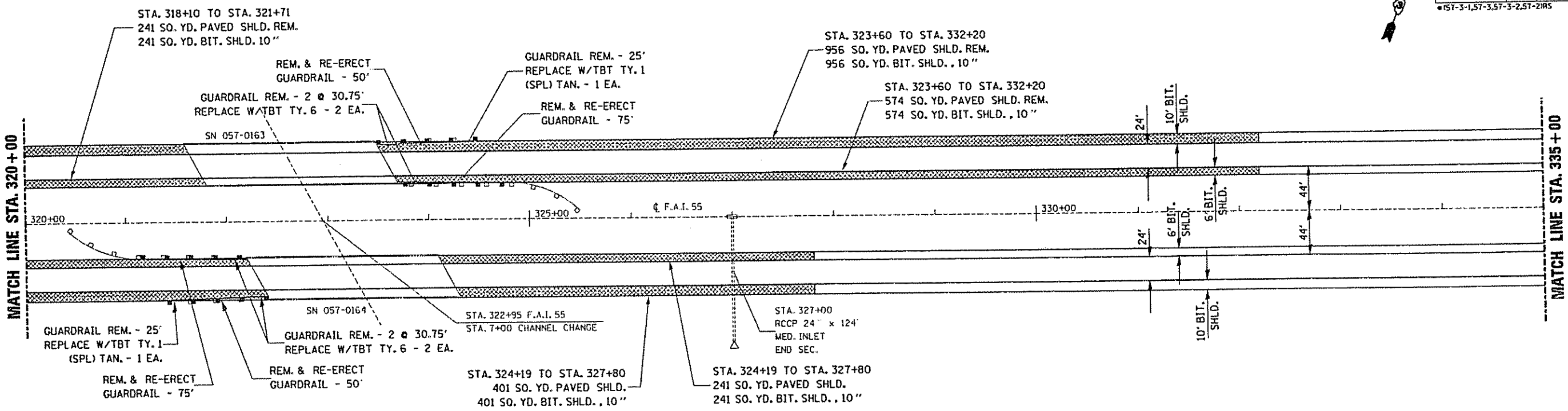

NOTE:
 CONCRETE HEADWALLS SHALL BE ADDED TO ALL EXISTING PIPE UNDERDRAIN OUTLETS FROM STA. 53+75 TO STA. 391+00

STA. 320+00 TO STA. 350+00

Example

P.A. L. NO.	SECTION	COUNTY	TOTAL SHEETS	SHEET NO.
55	*	McLEAN	139	32
STA. 350+00		TO STA. 380+00		
POL. AND DIST. NO.	ALIGNED	POL. AND PROJECT		
* 157-3-1,57-3,57-5-2,57-21RS				

ONLY 1 PER SHEET NEEDED

8 TON STONE DUMPED
RIPRAP, A4
W/FILTER FABRIC -
11.1 SQ. YD.
STA. 364+00
RCCP 24" x 74"
2 INLET BOX

MATCH LINE STA. 350+00

MATCH LINE STA. 365+00



MATCH LINE STA. 365+00

MATCH LINE STA. 380+00

NOTE:
CONCRETE HEADWALLS SHALL BE ADDED TO
ALL EXISTING PIPE UNDERDRAIN OUTLETS
FROM STA. 53+75 TO STA. 391+00

STA. 350+00 TO STA. 380+00

000
TTS.DGN

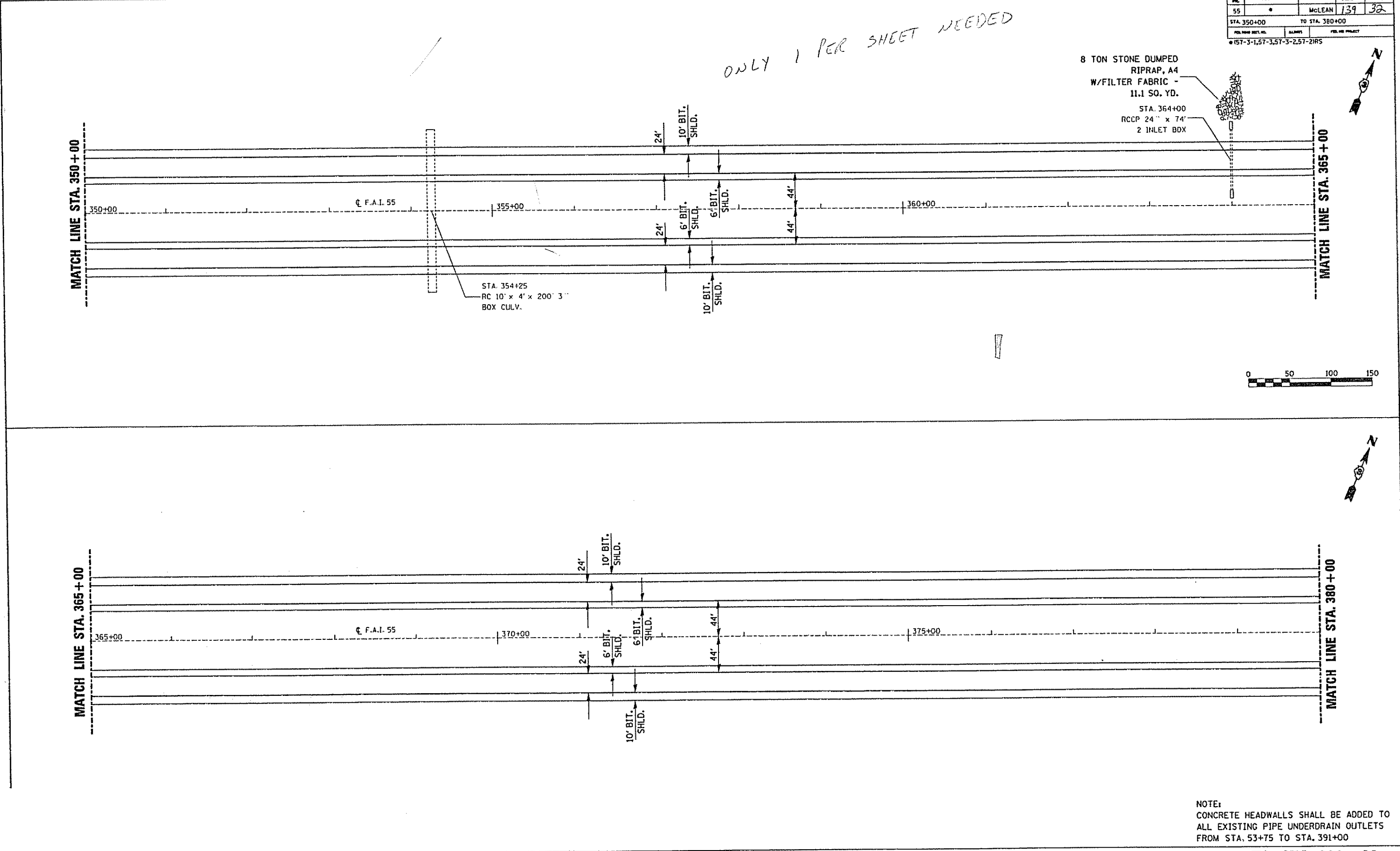

P.A.L. NO.	SECTION	COUNTY	TITLE	REV.
55	*	MCLEAN	139	33
STA. 380+00		TO STA. 410+00		
P.L. 1000 07/10/00		SCALE	FIELD PROJECT	
* 157-3-1.57-3.57-3-2.57-2HS				

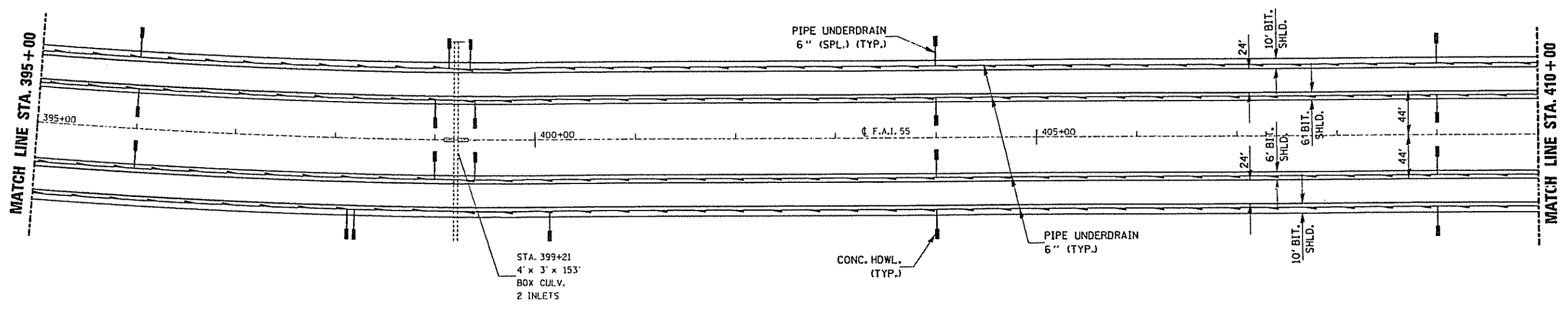
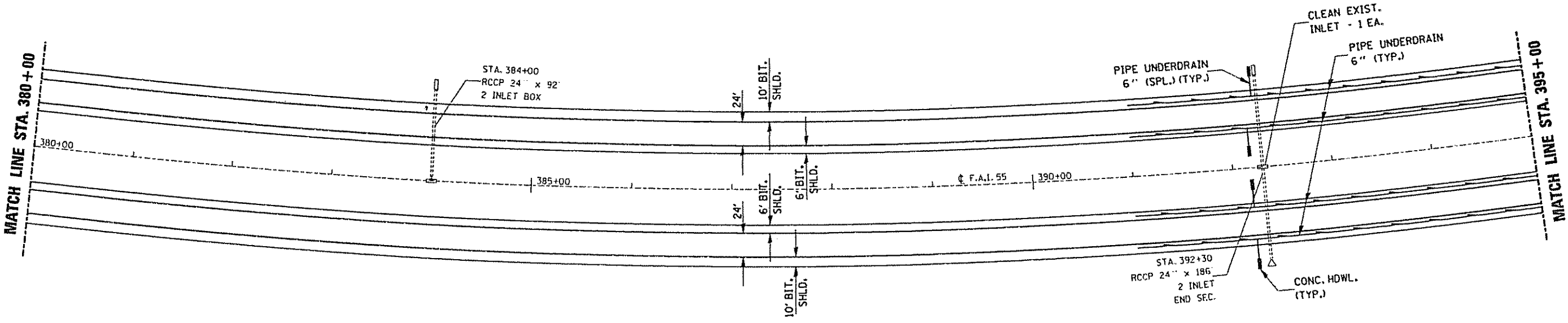

NOTE:
 CONCRETE HEADWALLS SHALL BE ADDED TO
 ALL EXISTING PIPE UNDERDRAIN OUTLETS
 FROM STA. 53+75 TO STA. 391+00

STA. 380+00 TO STA. 410+00

JAN. 11, 2000
 \EDCR100\B SHEETS.DGN

F.A.I. NO.	SECTION	COUNTY	TYP. SHEETS	SHEET NO.
55	B	McLEAH	139	34
STA. 410+00		TO STA. 440+00		
FED. ROAD DIST. NO.		ILLINOIS	FED. AID PROJECT	
157-3-1.57-3.57-3-2.57-2RS				

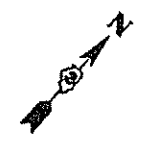
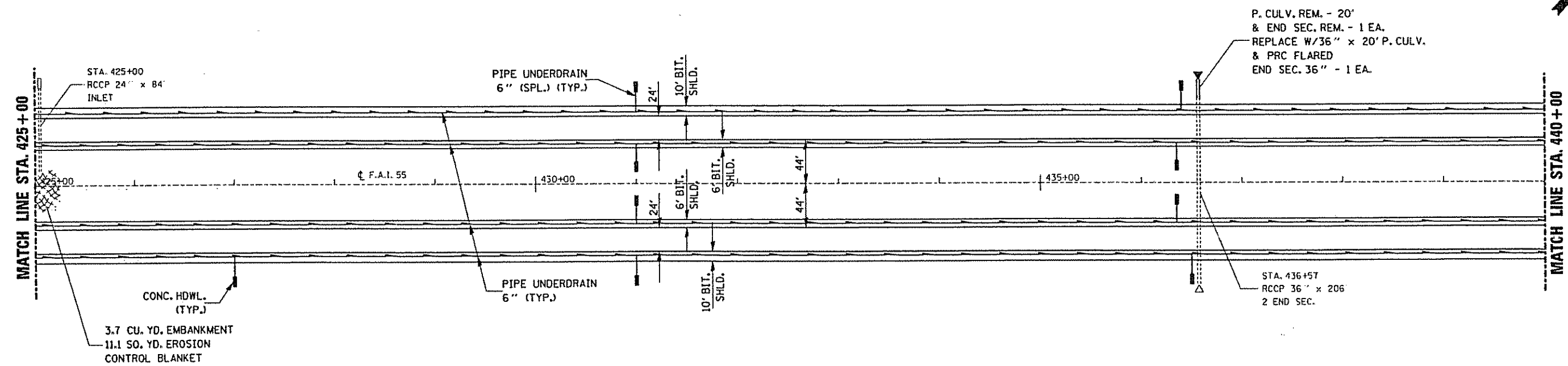
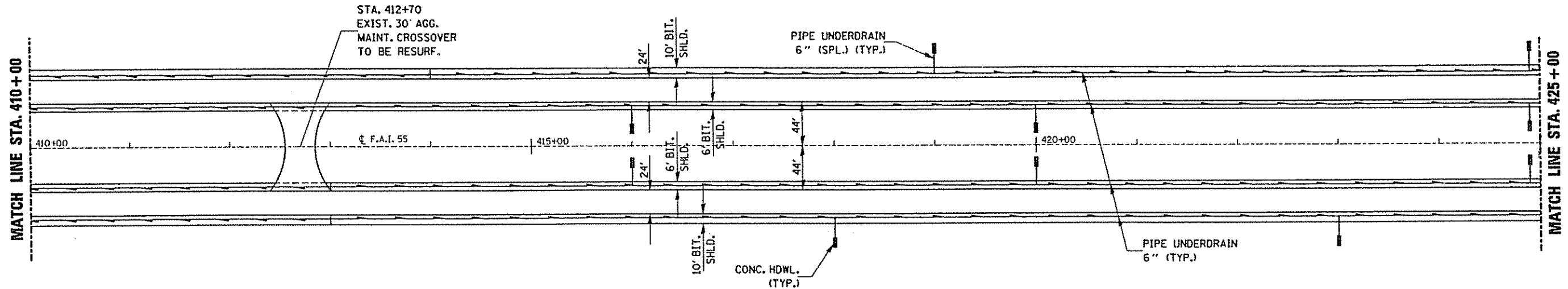
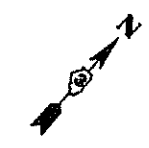

JAN. 11, 2000
VED021001 SHEETS.DGN

STA. 410+00 TO STA. 440+00

P.L. NO.	SECTION	COUNTY	SHEET NO.	TOTAL SHEETS
55		MCLEAN	139	35
STA. 440+00		TO STA. 470+00		
PROJECT NO. 157-3-1.57-3.57-3-2.57-21RS				

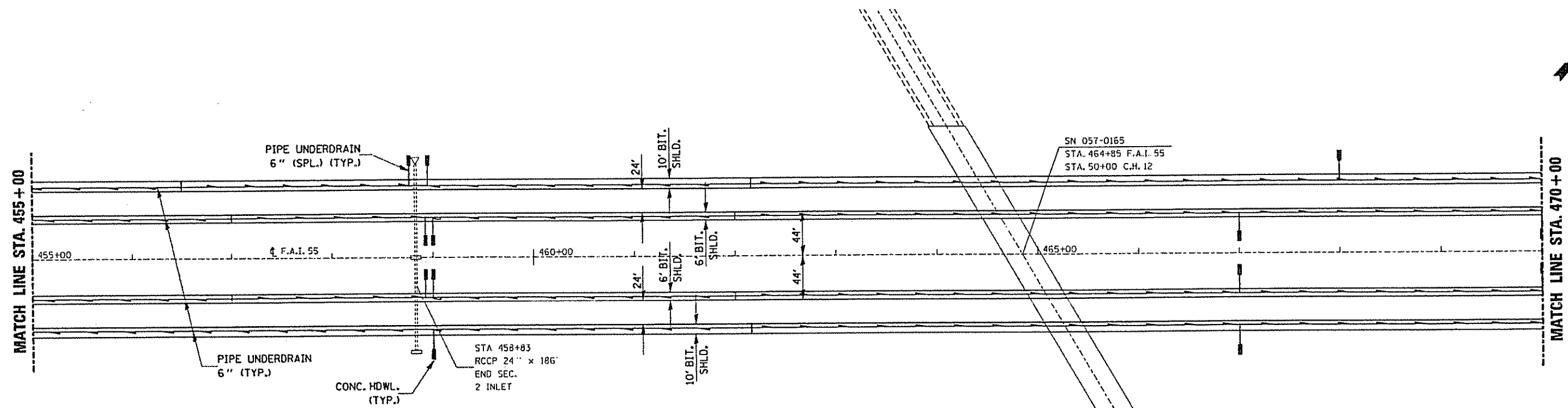
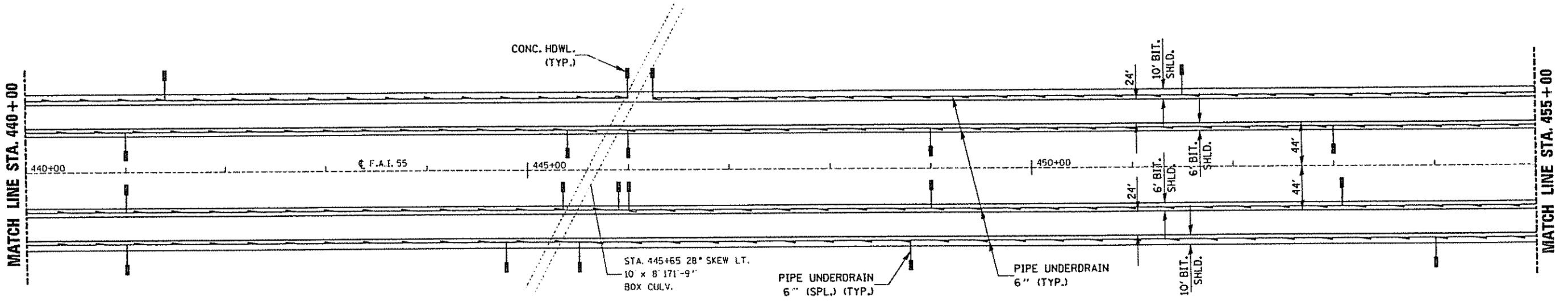
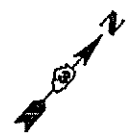

JAN. 11, 2000
VED02100\SHEETS.DGN

STA. 440+00 TO STA. 470+00

P.L. NO.	SECTION	COUNTY	DATE	SHEET NO.
55		McLEAN	139	36
STA. 470+00		TO STA. 500+00		
P.L. NO. 157-3-1.57-3.57-3-2.57-2RS		P.L. NO. PROJECT		

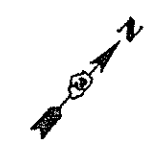
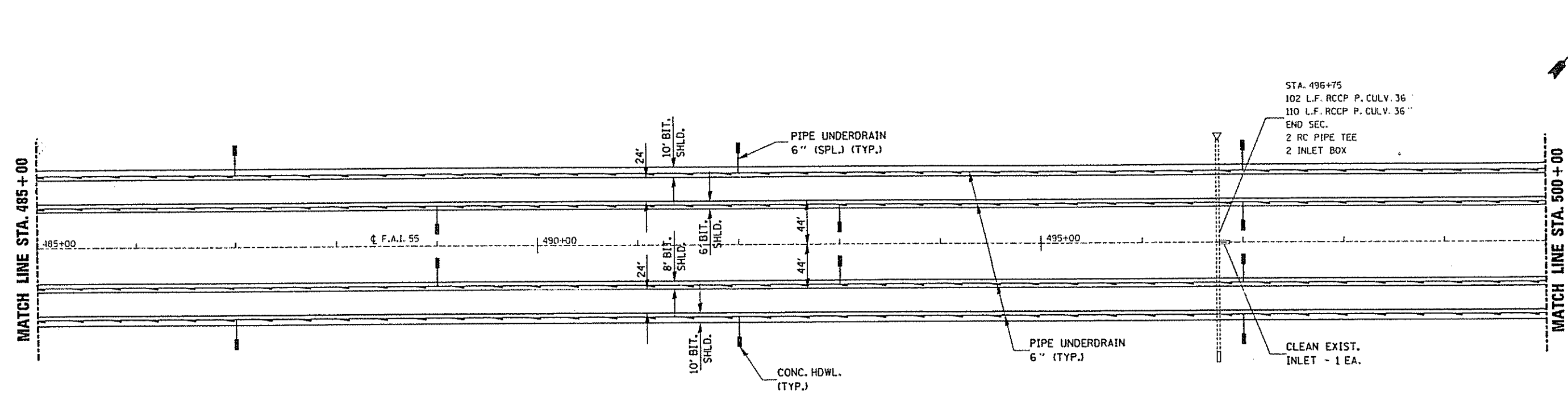
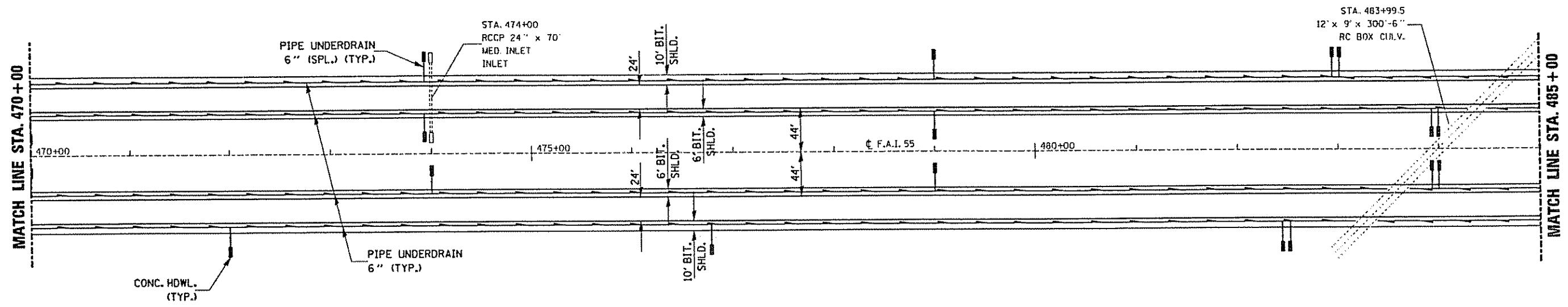
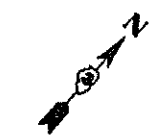

JAN. 11, 2000
VEDD2100NSHEETS.DGN

STA. 470+00 TO STA. 500+00

P.L. NO.	SECTION	COUNTY	TVA DIST.	SHEET NO.
55		McLEAN	139	37
STA. 500+00		TO STA. 530+00		
P.L. NO. DIST. NO.		P.L. NO. DIST. NO.		
© 197-3-1,57-3,57-3-2,57-21RS				

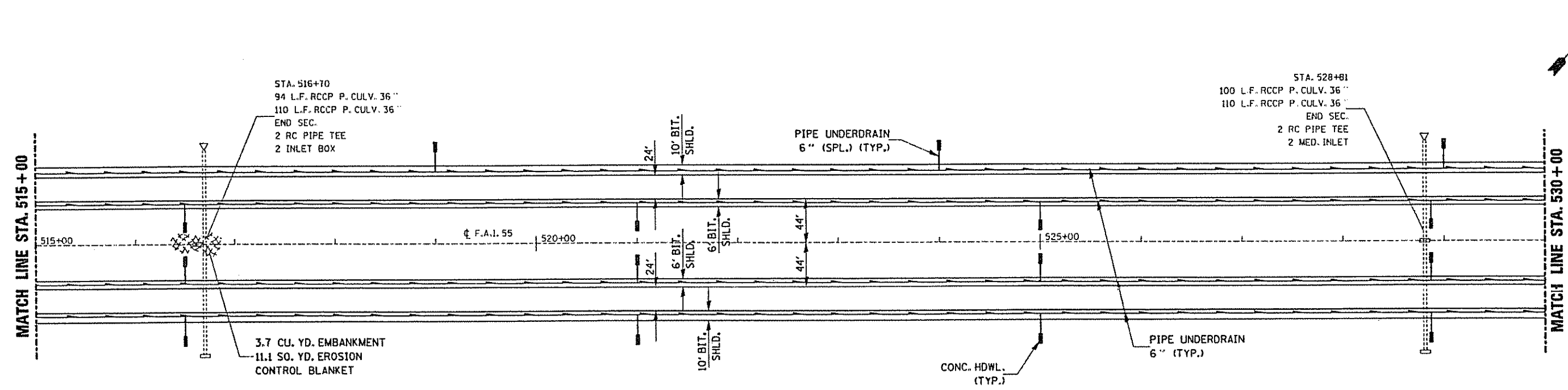
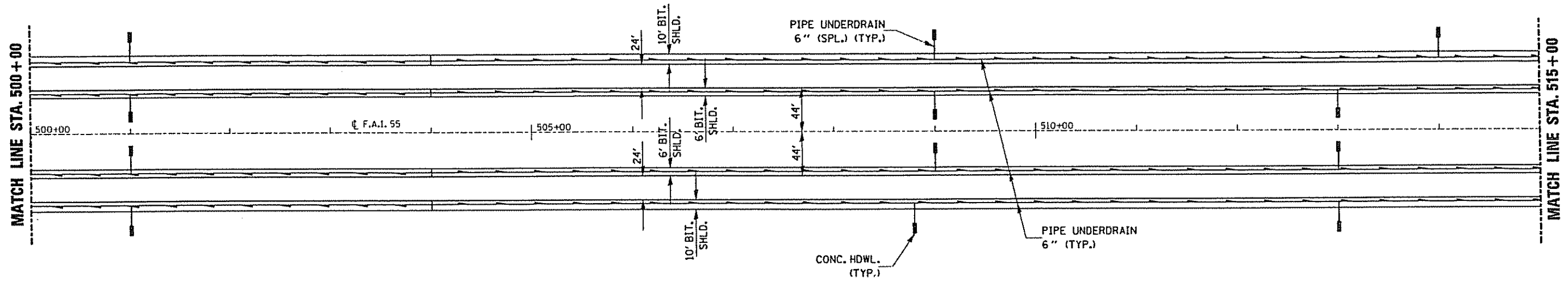
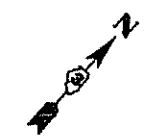

JAN. 5, 2000
 \EDOR100.SHEETS.DGN

STA. 500+00 TO STA. 530+00

F.A.I. NO.	SECTION	COUNTY	TOTAL SHEETS	SHEET NO.
55	0	MCLEAN	139	38
STA. 530+00		TO STA. 560+00		
F.I.L. PROJ. NO.		ALWAYS	F.I.L. PROJ. NO.	
157-3-1,57-3,57-3-2,57-2RS				

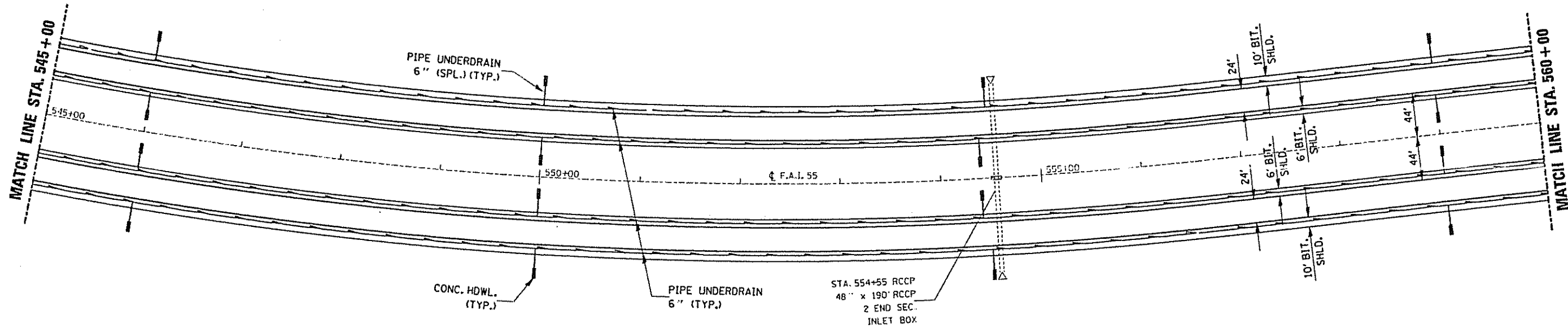
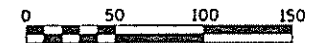
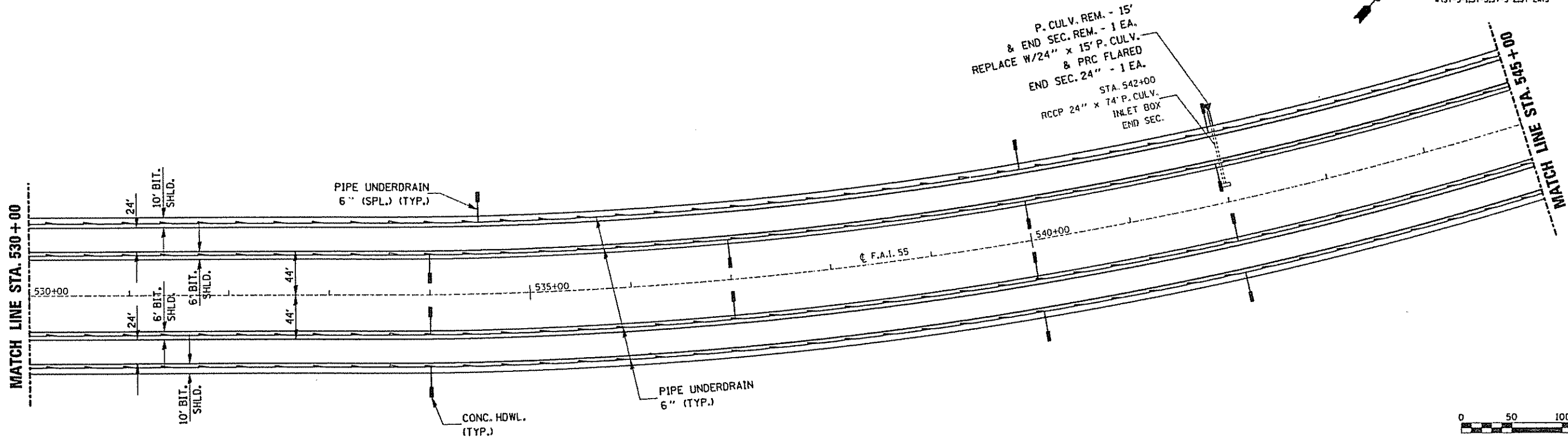

STA. 530+00 TO STA. 560+00

P.A.L. NO.	SECTION	COUNTY	TYPE	SHEET NO.
55		McLEAN	139	39
STA. 560+00		TO STA. 590+00		
P.L. NO. 157-3-1, 57-3-57-3-2, 57-2RS				

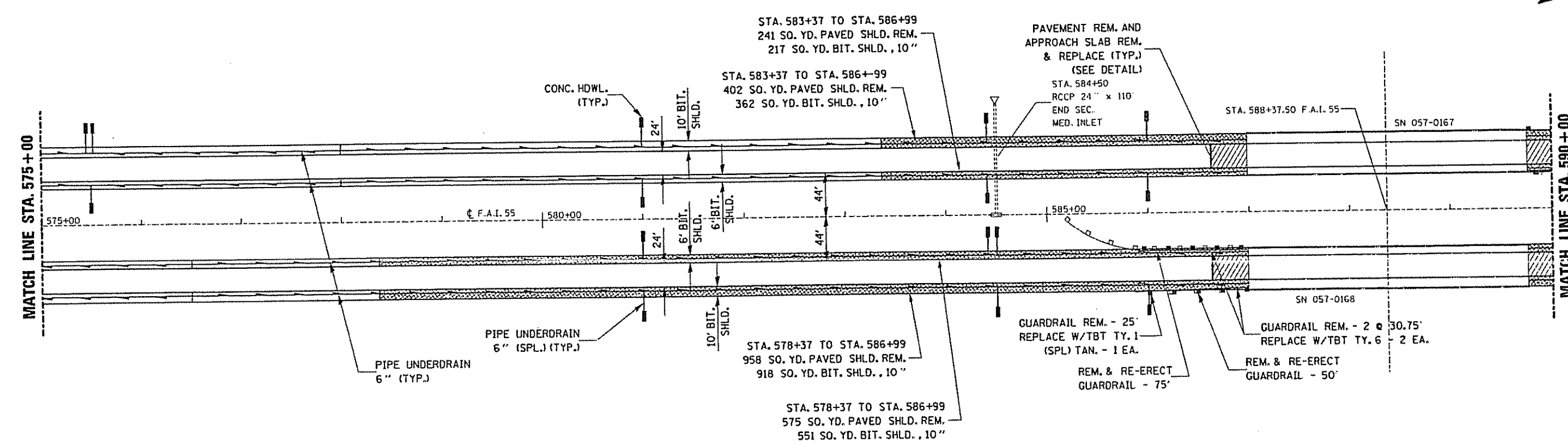
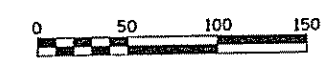
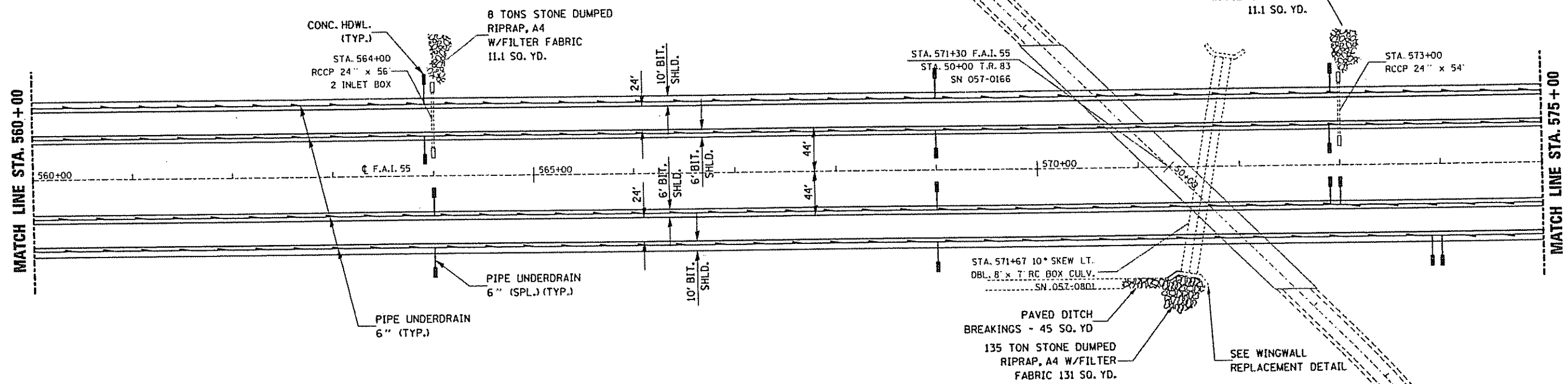

STA. 560+00 TO STA. 590+00

JAN. 11, 2000
VED021001.SHEETS.DGN

P.L. & S.	SECTION	COUNTY	TOTAL SHEETS	SHEET NO.
55	0	McLEAN	139	40
STA. 590+00		TO STA. 620+00		
P.L. 1000 0000		SCALE	P.L. 1000 0000	
* 157-3-1.57-3.57-3-2.51-2R5				

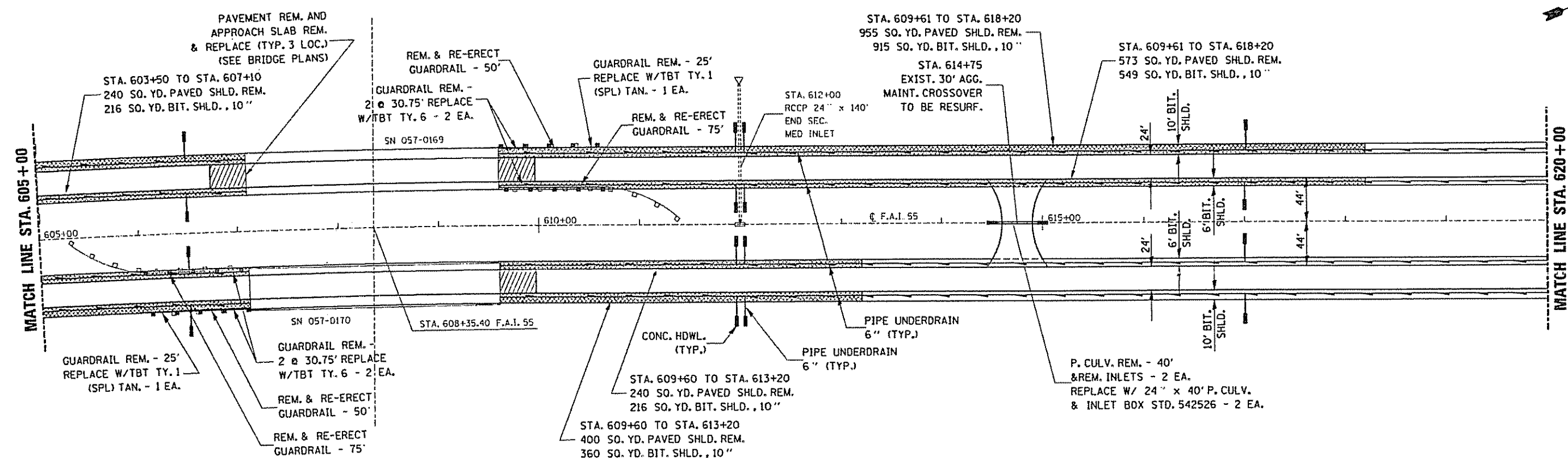
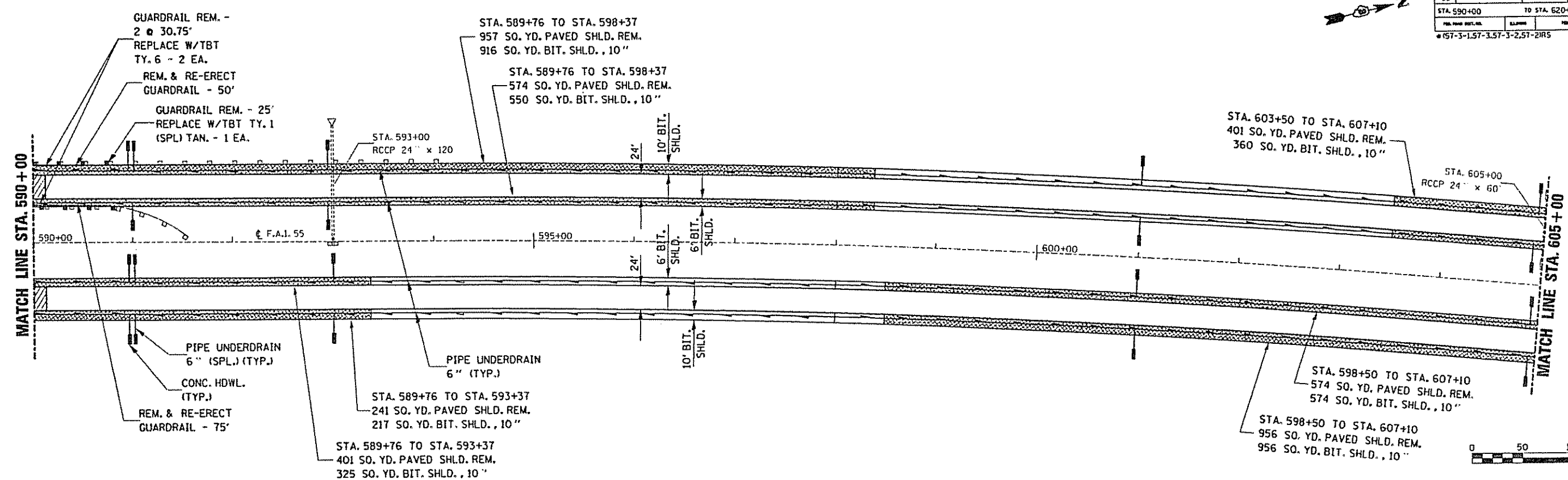

STA. 590+00 TO STA. 620+00

JAN. 11, 2000
 \ED02100\SHEETS.DGN

S.D.S. NO.	SECTION	COUNTY	SHEET NO.	TOTAL SHEETS
55	*	McLEAN	139	41
STA. 620+00		TO STA. 635+00		
FOLDER DET. NO.		BLANKS	FOLDER PROJECT	
* (57-3-1,57-3,57-3-2,57-2RS)				

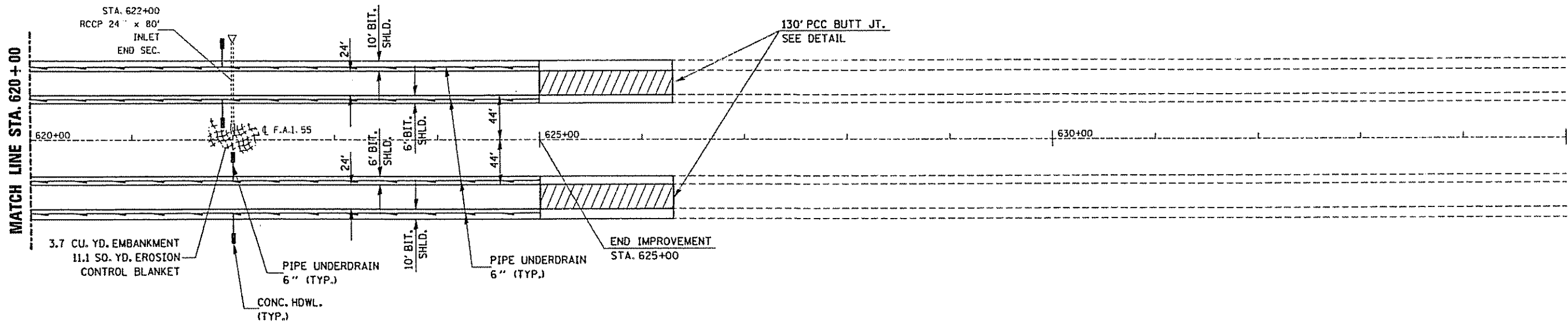

JAN. 11, 2000
 \ED02100\SHEETS.DGN

FILE NO.	SECTION	COUNTY	TOTAL SHEETS	SHEET NO.
55	6	MCLEAN	139	42
STA.	TO STA.			
POL. AND DIST. NO.	ALIGNED	POL. AND DIST.		
© 01-3-157-357-5-257-275				



NOTE:
 RAMP RESURFACING ENDS AT C.H. 29
 C.H. 29 SHALL NOT BE RESURFACED

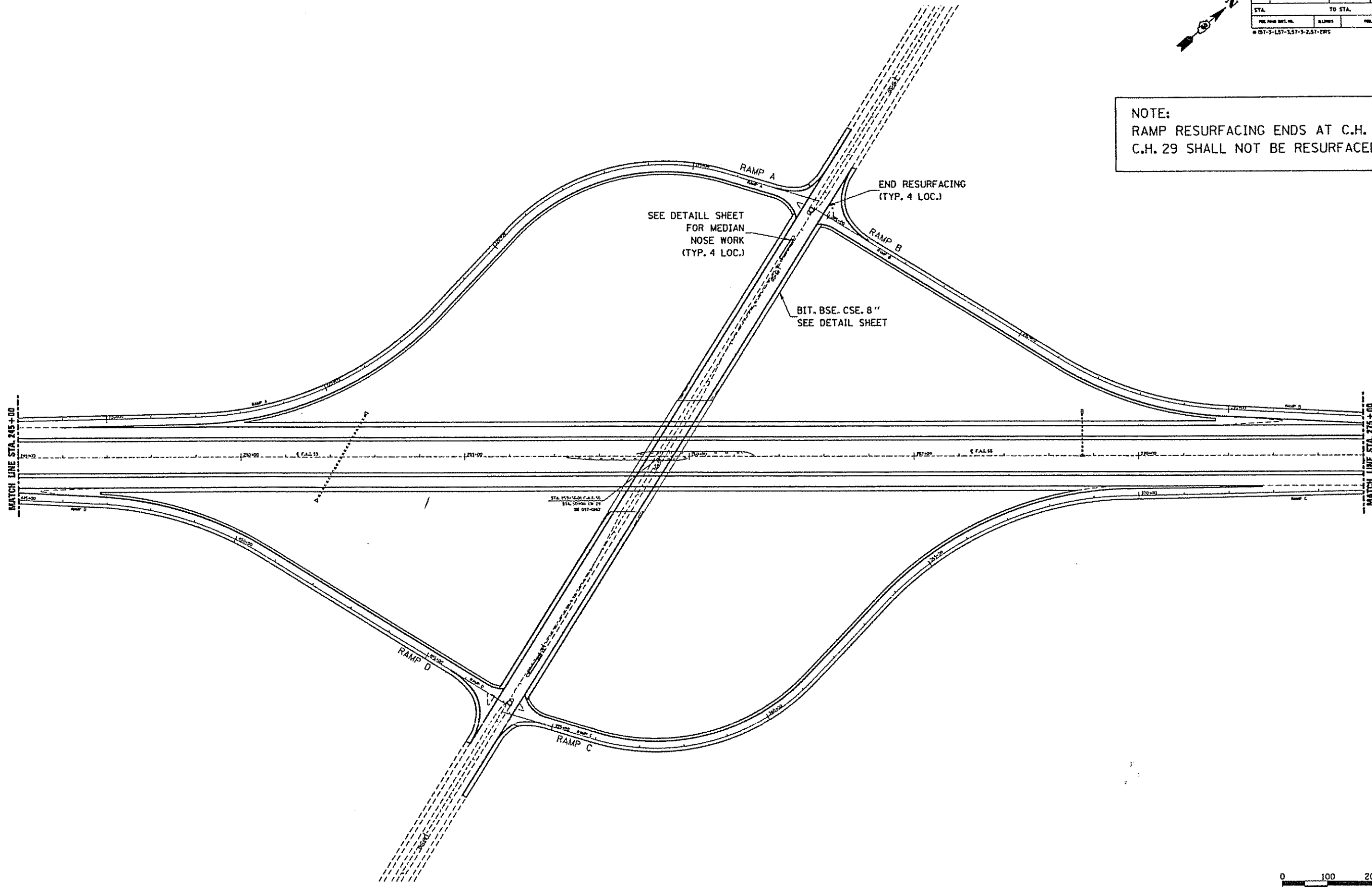

JAN. 13. 2000
 \ED02100\SHEETS.DGN



PLAN VIEW
 RAMPS

F.A.J. RTE.	SECTION	COUNTY	TOTAL SHEETS	SHEET NO.
55	*	MCLEAN	139	43
STA.	TO STA.			
FED. ROAD DIST. NO.	ILLINOIS	FED. AID PROJECT		
● 57-3-1, 57-3, 57-3-2, 57-21 RS				

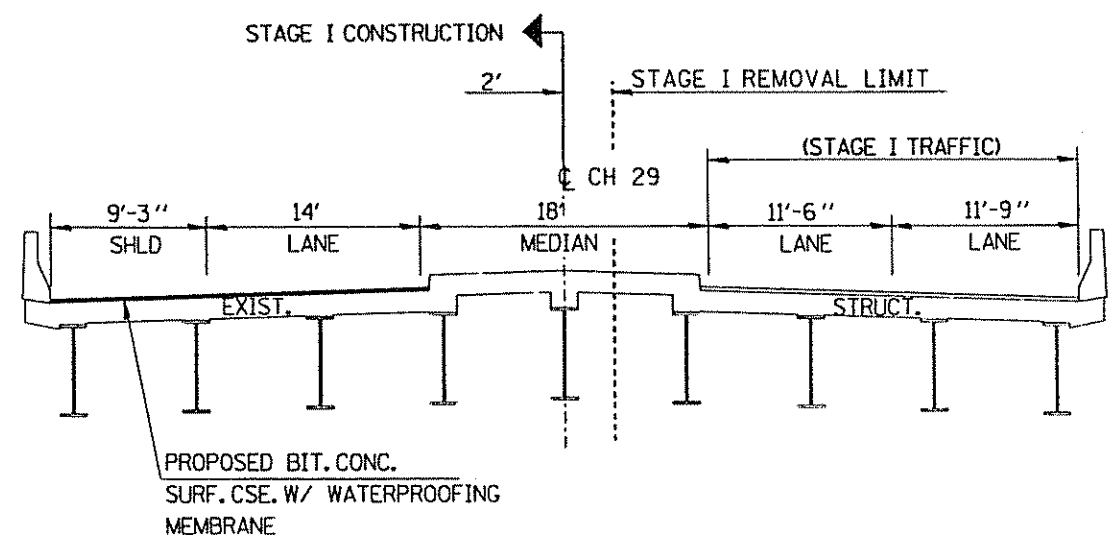

STAGE I
S. N. 057-0162

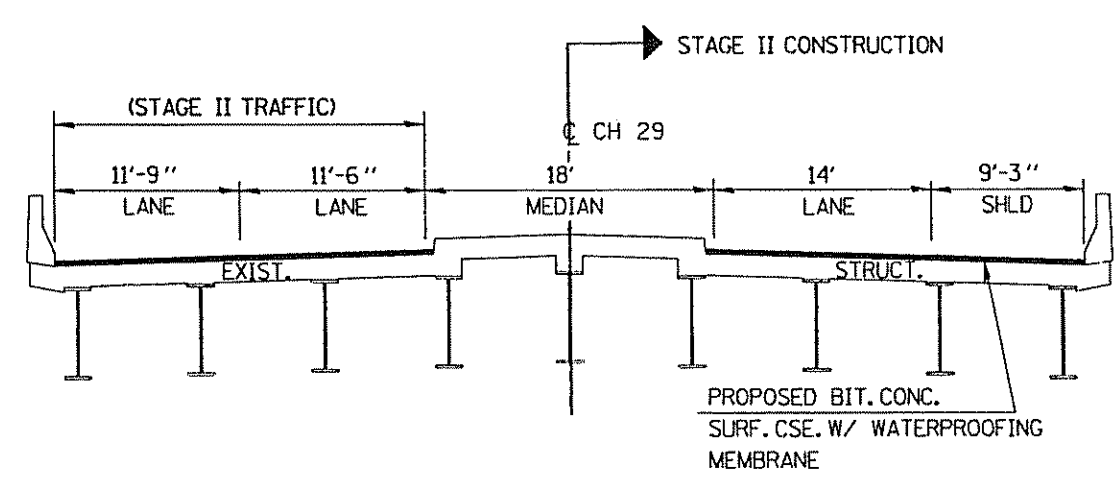

STAGE II
S. N. 057-0162

JAN. 11, 2000
VED02100.DETAILS.DGN

PLAN NO.	SECTION	COUNTY	REV.	SHEET NO.
55	#	McLEAN	139	49
STA.		TO STA.		
POL. AND DIST. NO.		SLOPES		PER. OR PROJECT
# 057-3-157-3, 57-3-2, 57-2, 75				

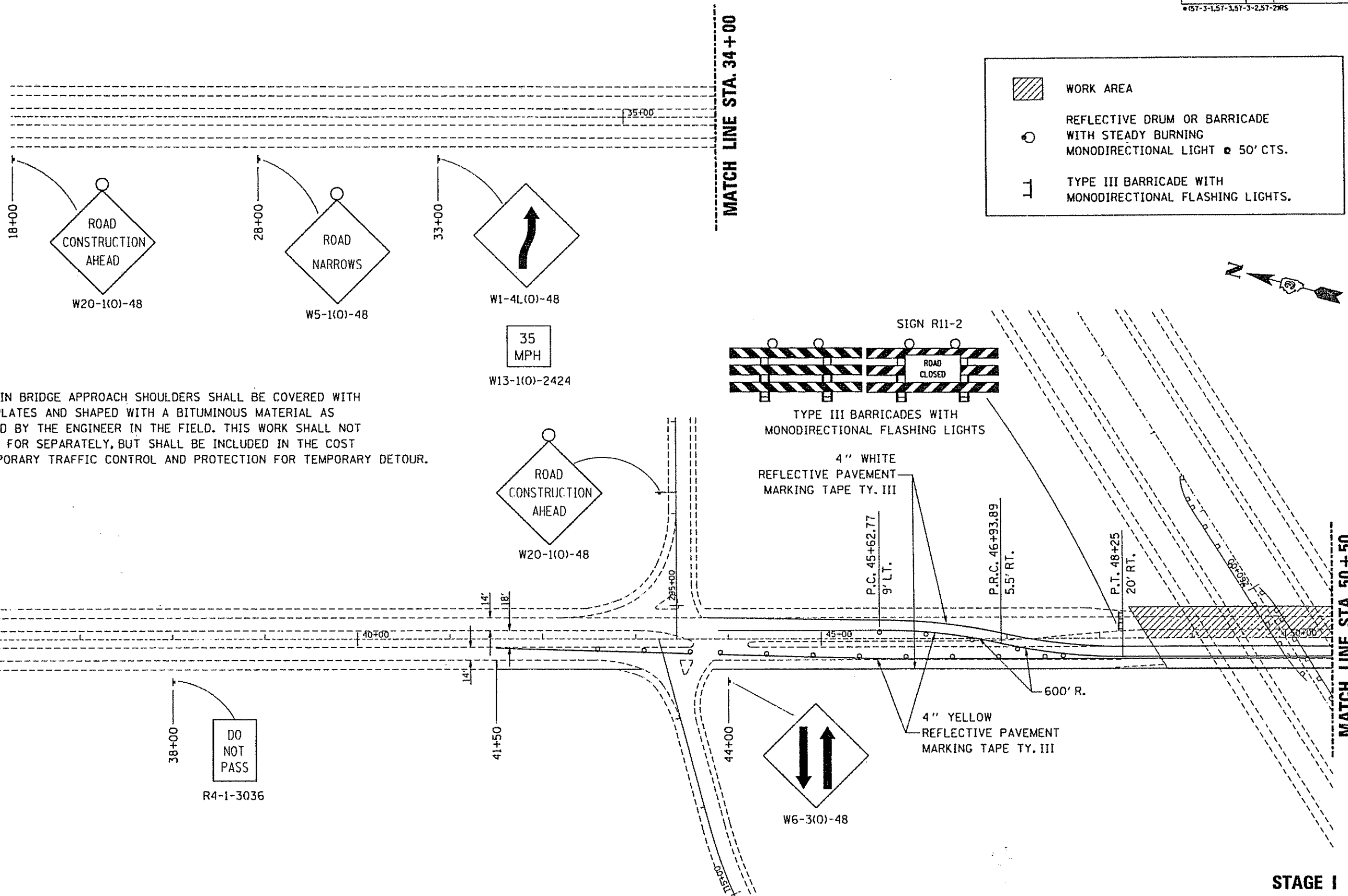

NOTE:
 INLETS IN BRIDGE APPROACH SHOULDERS SHALL BE COVERED WITH STEEL PLATES AND SHAPED WITH A BITUMINOUS MATERIAL AS DIRECTED BY THE ENGINEER IN THE FIELD. THIS WORK SHALL NOT BE PAID FOR SEPARATELY, BUT SHALL BE INCLUDED IN THE COST OF TEMPORARY TRAFFIC CONTROL AND PROTECTION FOR TEMPORARY DETOUR.



JAN. 11, 2000
 \EDD2100\1\SHEETS.DGN

STAGE I
 STAGING PLANS
 S.N. 057-0162

P.A.L. NO.	SECTION	COUNTY	TOTAL SHEETS	SHEET NO.
55		McLEAN	139	45
STA.		TO STA.		
P.L. PROJ. NO.		P.L. PROJ. NAME		
© (57-3-1,57-3,57-3-2,57-2)R5				

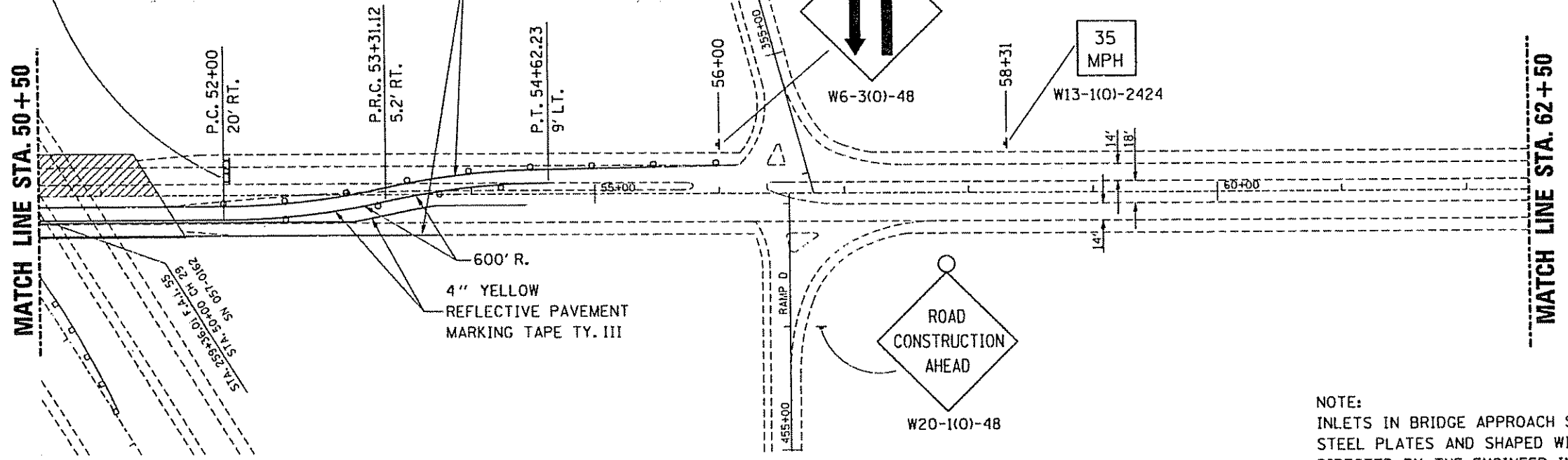
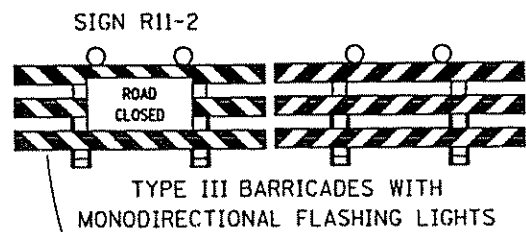

NOTE:
INLETS IN BRIDGE APPROACH SHOULDERS SHALL BE COVERED WITH STEEL PLATES AND SHAPED WITH A BITUMINOUS MATERIAL AS DIRECTED BY THE ENGINEER IN THE FIELD. THIS WORK SHALL NOT BE PAID FOR SEPARATELY, BUT SHALL BE INCLUDED IN THE COST OF TEMPORARY TRAFFIC CONTROL AND PROTECTION FOR TEMPORARY DETOUR.

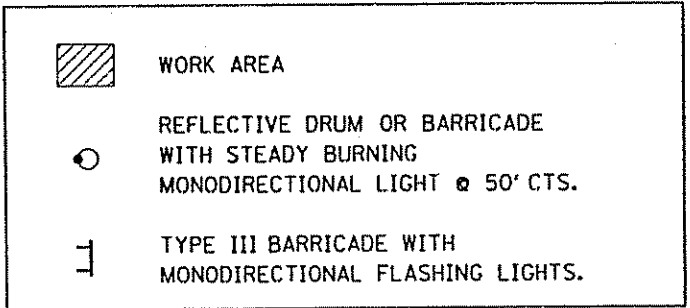

MATCH LINE STA. 62+50

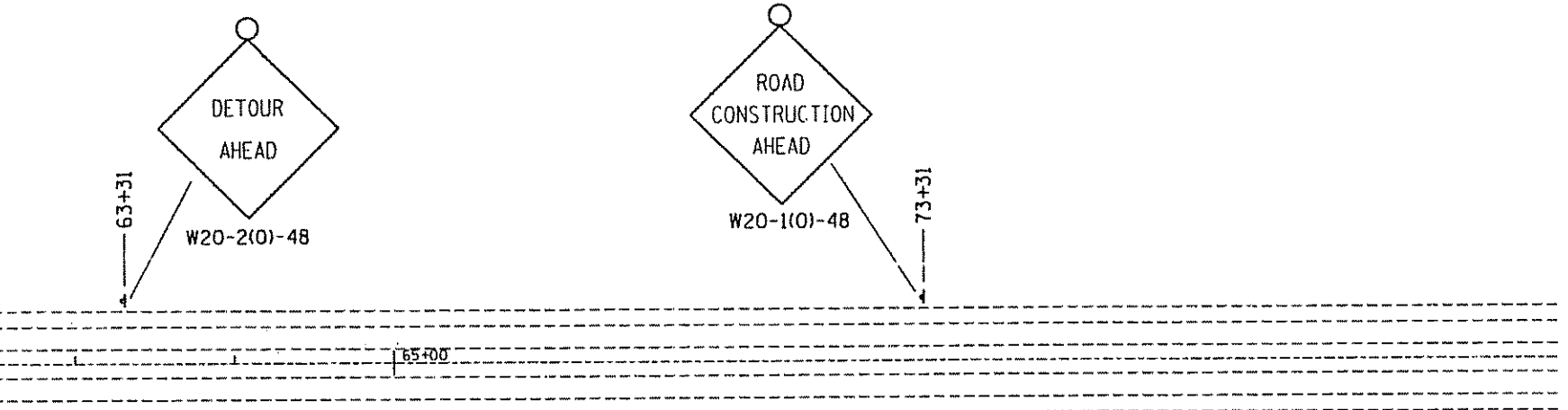

STAGE I
STAGING PLANS
S.N. 057-0162

JAN. 11, 2000
\\ED021001\SHEETS.DGN

F.A.S. NO.	SECTION	COUNTY	SHEET NO.	TOTAL SHEETS
55		MCCLEAM	39	40
STA.	TO STA.			
FILE NAME REF. NO.	SCALE	FILE NO. PROJECT		
157-3-1.57-3.57-3-2.57-21RS				

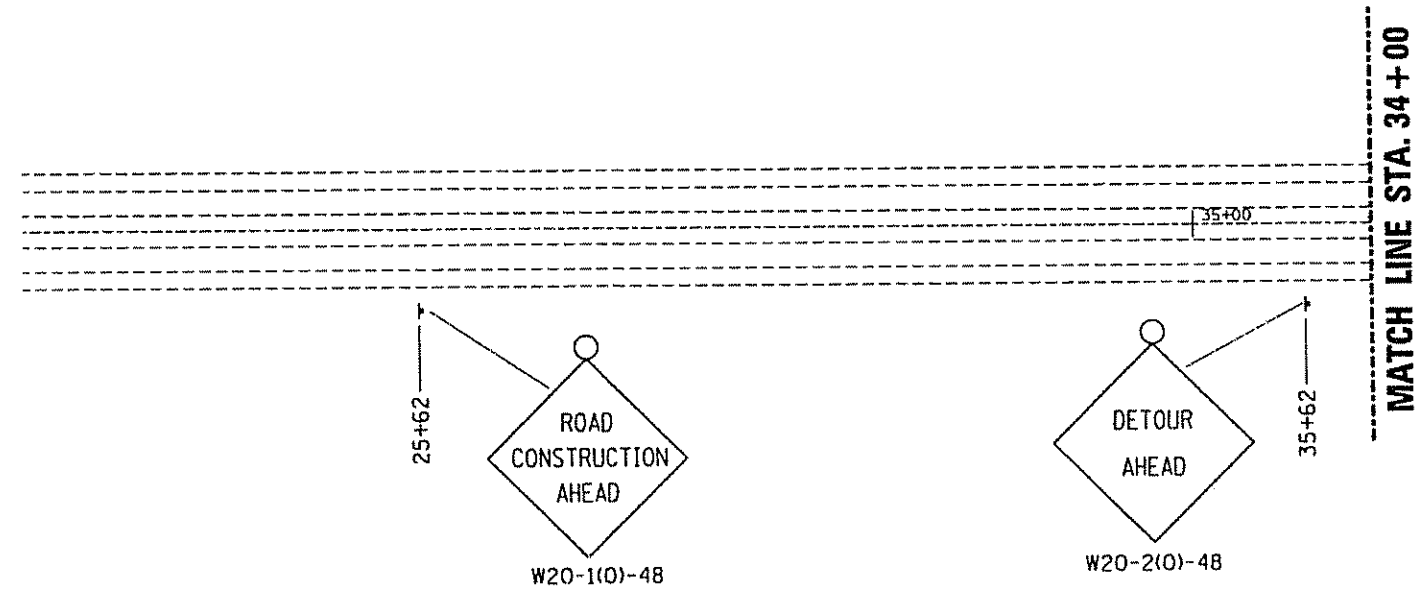

WORK AREA

REFLECTIVE DRUM OR BARRICADE WITH STEADY BURNING MONODIRECTIONAL LIGHT @ 50' CTS.

TYPE III BARRICADE WITH MONODIRECTIONAL FLASHING LIGHTS.



NOTE:
 INLETS IN BRIDGE APPROACH SHOULDERS SHALL BE COVERED WITH STEEL PLATES AND SHAPED WITH A BITUMINOUS MATERIAL AS DIRECTED BY THE ENGINEER IN THE FIELD. THIS WORK SHALL NOT BE PAID FOR SEPARATELY, BUT SHALL BE INCLUDED IN THE COST OF TEMPORARY TRAFFIC CONTROL AND PROTECTION FOR TEMPORARY DETOUR.

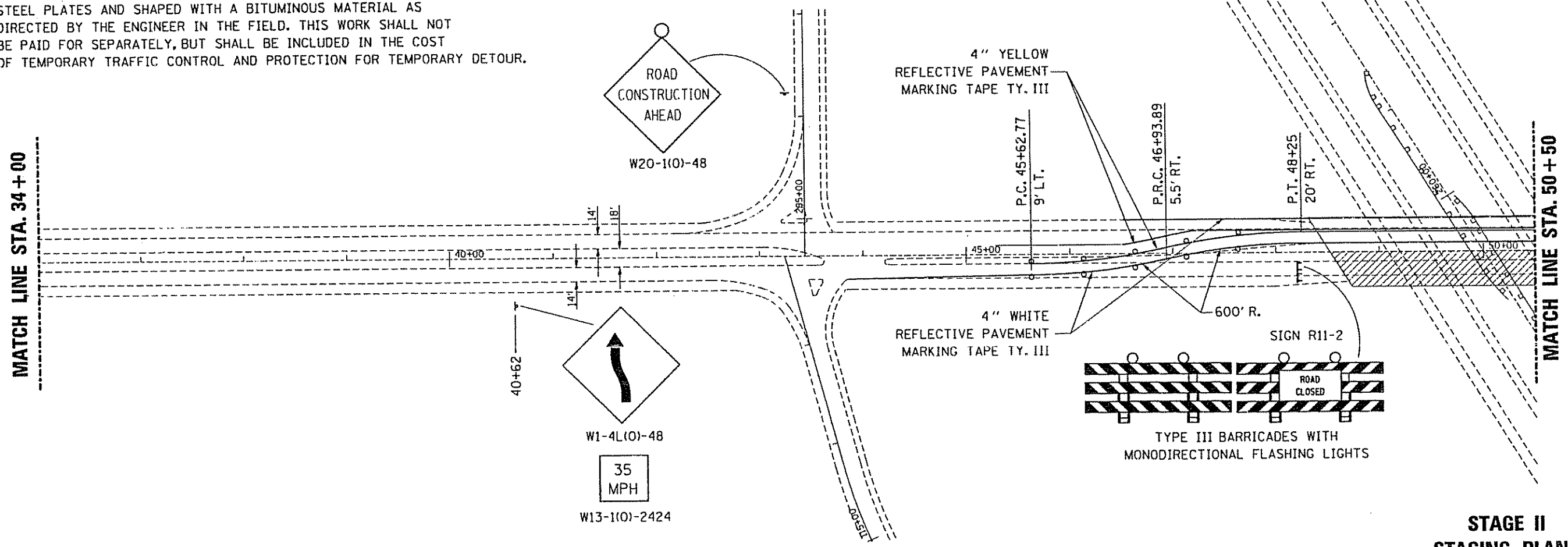

**STAGE II
 STAGING PLANS
 S.N. 057-0162**

JAN. 11, 2000
 \EDD2100\3SHEETS.DGN

P.A.S. NO.	SECTION	COUNTY	SHEET NO.	TOTAL SHEETS
55		McLEAN	139	47
STA.	TO STA.			
P.L. ROAD DIST. NO.		BLANKET	P.L. NO. PROJECT	
* 157-3-1.57-3.57-3-2.57-2RS				

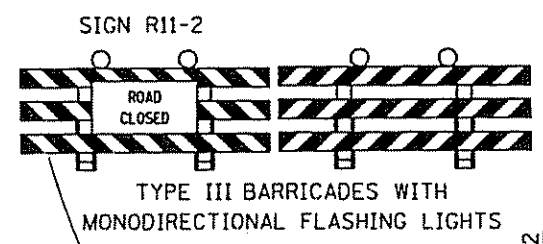

MATCH LINE STA. 50+50

MATCH LINE STA. 62+50

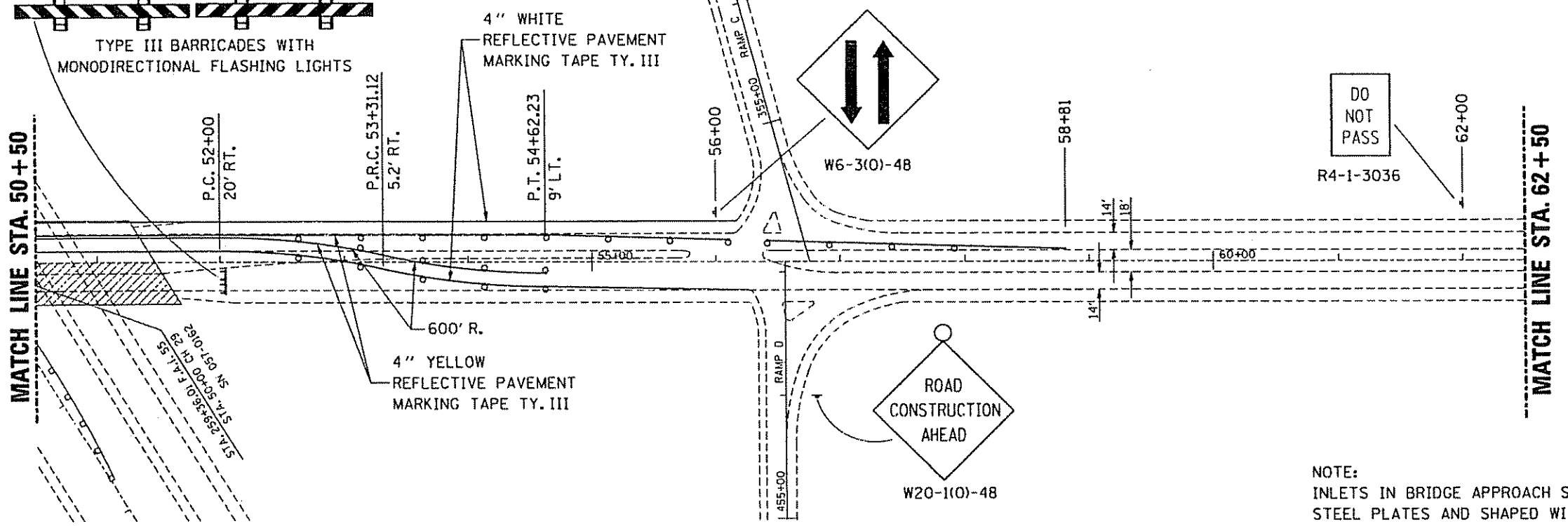

NOTE:
 INLETS IN BRIDGE APPROACH SHOULDERS SHALL BE COVERED WITH STEEL PLATES AND SHAPED WITH A BITUMINOUS MATERIAL AS DIRECTED BY THE ENGINEER IN THE FIELD. THIS WORK SHALL NOT BE PAID FOR SEPARATELY, BUT SHALL BE INCLUDED IN THE COST OF TEMPORARY TRAFFIC CONTROL AND PROTECTION FOR TEMPORARY DETOUR.

	WORK AREA
	REFLECTIVE DRUM OR BARRICADE WITH STEADY BURNING MONODIRECTIONAL LIGHT @ 50' CTS.
	TYPE III BARRICADE WITH MONODIRECTIONAL FLASHING LIGHTS.

MATCH LINE STA. 62+50

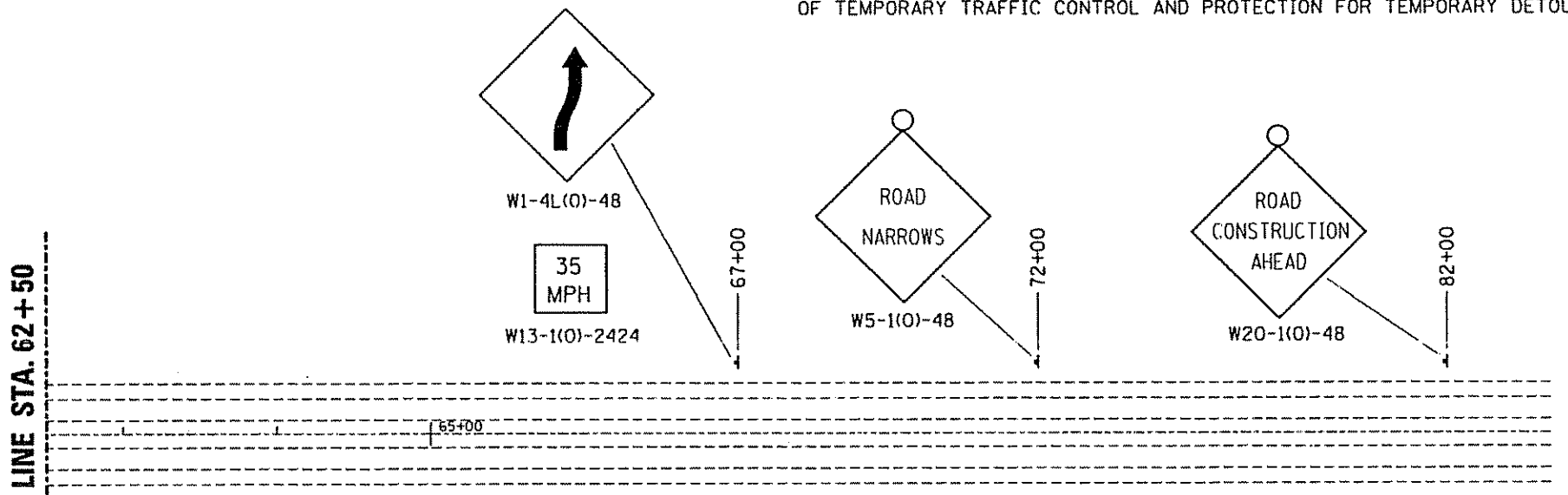

**STAGE II
 STAGING PLANS
 S.N. 057-0162**

JAN. 11, 2000
 \ED02100\SHEETS.DGN

SHOULDER REMOVAL & REPLACEMENT		
S. N.	STATIONS	STATIONS
057-0163	318+10 TO 321+71.	323+60 TO 332+20
057-0164	313+70 TO 322+30,	324+19 TO 327+80

F.L.S. NO.	SECTION	COUNTY	TOTAL SHEETS	SHEET NO.
55		McLEAN	139	48
STA. TO STA.				
FILING DIST. NO.		BLINDS	FILING PROJECT	

057-3-LS7-3,57-3-2,57-2RS

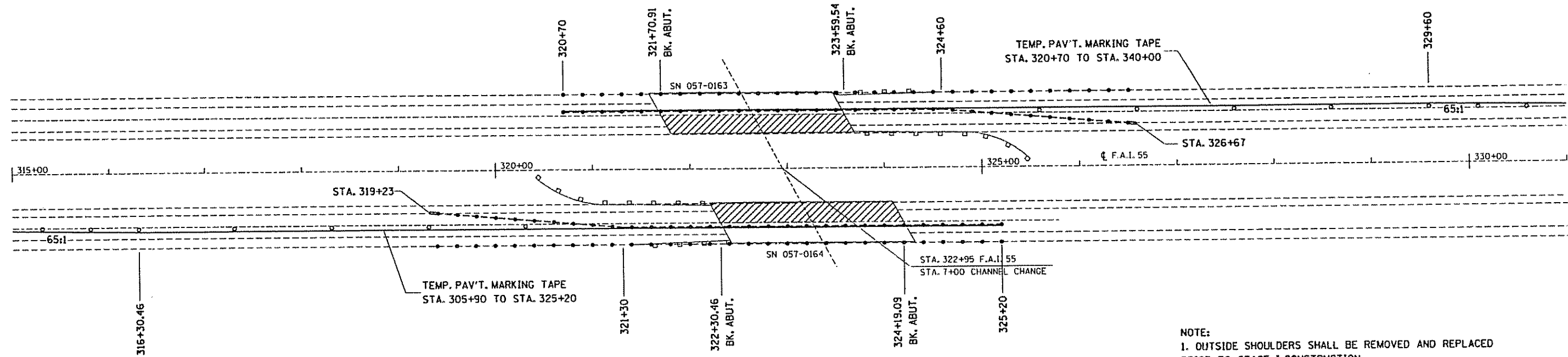

- NOTE:
1. OUTSIDE SHOULDERS SHALL BE REMOVED AND REPLACED PRIOR TO STAGE I CONSTRUCTION.
 2. MEDIAN SHOULDERS SHALL BE REMOVED AND REPLACED PRIOR TO STAGE II CONSTRUCTIONS.

STAGE I

	WORK AREA
	BI-DIRECTIONAL STEADY BURNING LIGHTS AND DOUBLE VERTICAL PANELS @ 20' CTS.
	DRUM WITH STEADY BURNING LIGHT
	TEMPORARY CONCRETE BARRIER
	TEMPORARY CONCRETE BARRIER TERMINAL SECTION

FOR ADDITIONAL DETAILS SEE STANDARD 701402

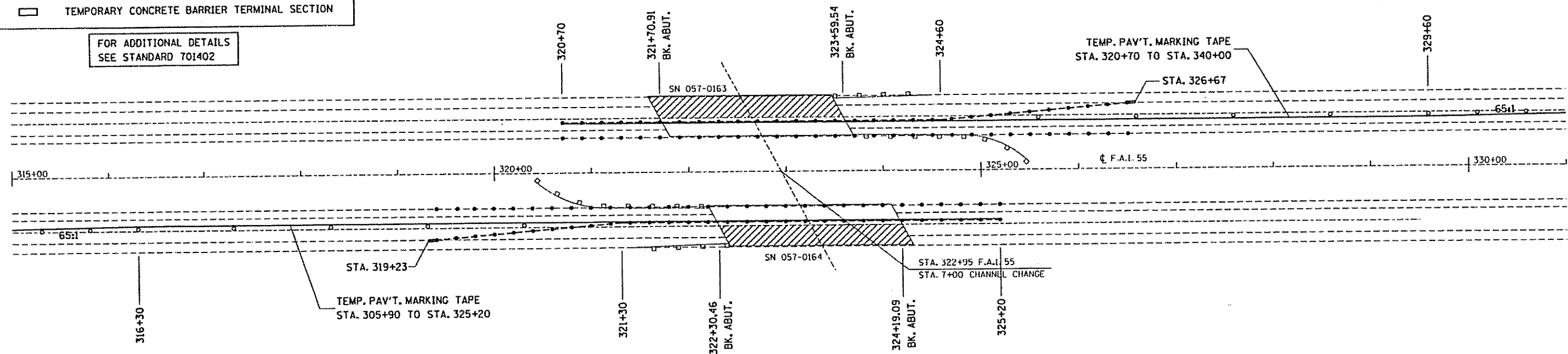
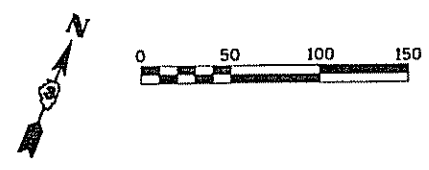





STAGE II STAGING PLANS

S.N. 057-0163 & S.N. 057-0164

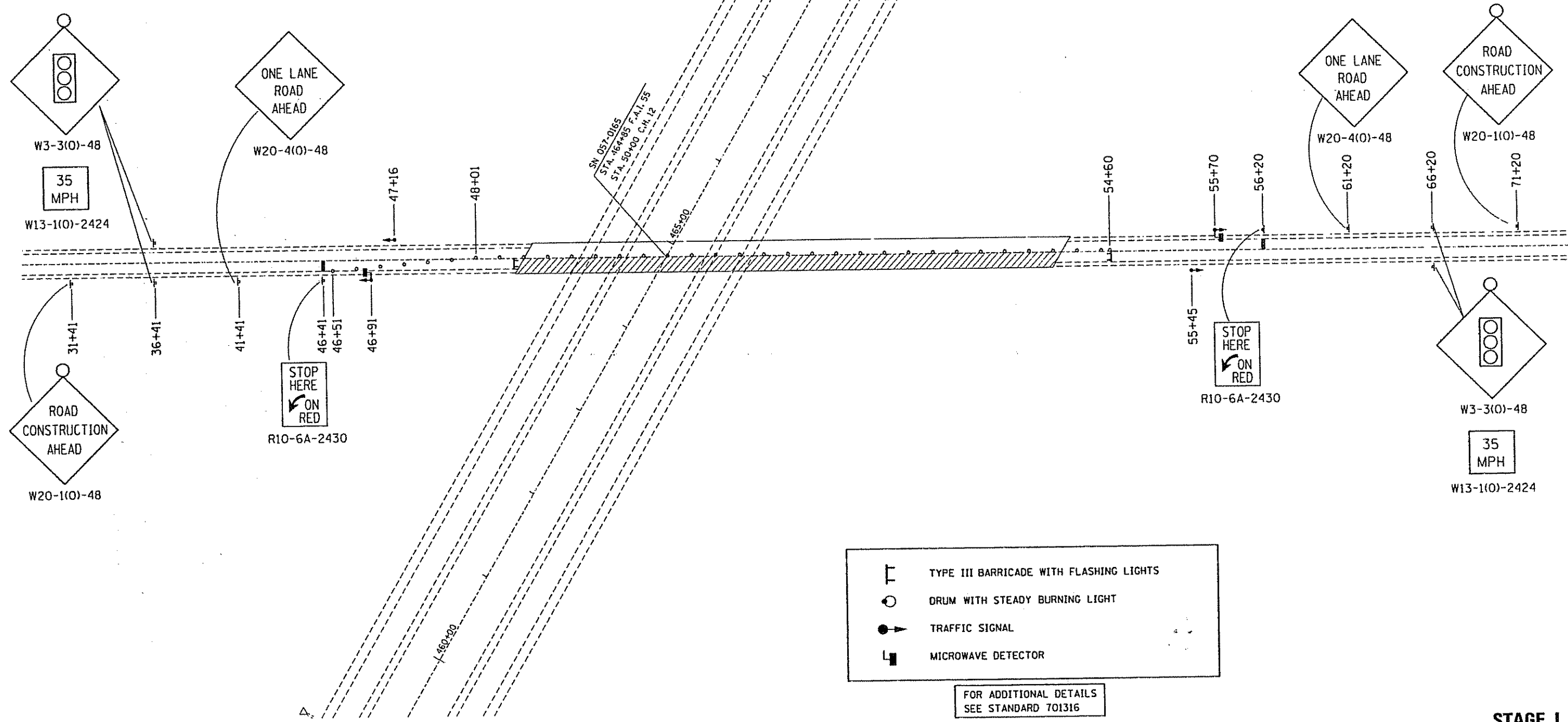
SECTION	COUNTY	TOTAL SHEETS	SHEET NO.
55	MCLEAN	139	49
STA. TO STA.			
FED. ROAD DIST. NO.		ALIGNMENT	FED. AID PROJECT
# 157-3-1.57-3.57-3-2.57-2IRS			

NOTE:
 INLETS IN BRIDGE APPROACH SHOULDERS SHALL BE COVERED WITH STEEL PLATES AND SHAPED WITH A BITUMINOUS MATERIAL AS DIRECTED BY THE ENGINEER IN THE FIELD. THIS WORK SHALL NOT BE PAID FOR SEPARATELY, BUT SHALL BE INCLUDED IN THE COST OF TEMPORARY TRAFFIC CONTROL AND PROTECTION FOR TEMPORARY DETOUR.



-  TYPE III BARRICADE WITH FLASHING LIGHTS
-  DRUM WITH STEADY BURNING LIGHT
-  TRAFFIC SIGNAL
-  MICROWAVE DETECTOR

FOR ADDITIONAL DETAILS
 SEE STANDARD 701316

STAGE I
STAGING PLANS
S.N. 057-0165

P.L. & SHEET NO.	SECTION	COUNTY	SPR. DIST.	SHEET NO.
55	#	McLEAN	139	50
STA.	TO STA.			
MILEAGE METHOD				
ALONG PROJECT				
S.N. 057-0165				

NOTE:
 INLETS IN BRIDGE APPROACH SHOULDERS SHALL BE COVERED WITH STEEL PLATES AND SHAPED WITH A BITUMINOUS MATERIAL AS DIRECTED BY THE ENGINEER IN THE FIELD. THIS WORK SHALL NOT BE PAID FOR SEPARATELY, BUT SHALL BE INCLUDED IN THE COST OF TEMPORARY TRAFFIC CONTROL AND PROTECTION FOR TEMPORARY DETOUR.

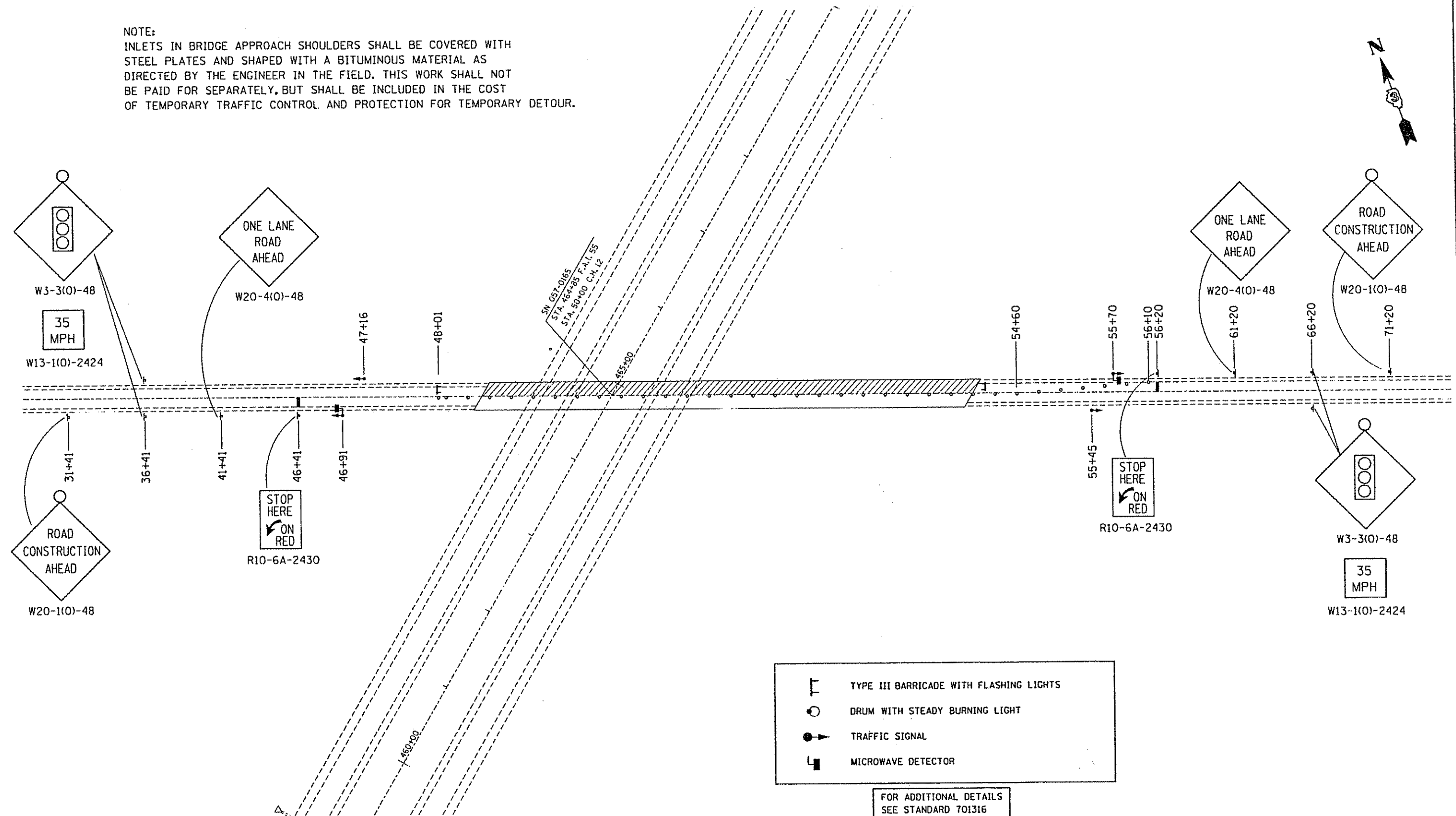





JAN, 13, 2000
 \ED021001\SHEETS.DGN

STAGE II
 STAGING PLANS
 S.N. 057-0165

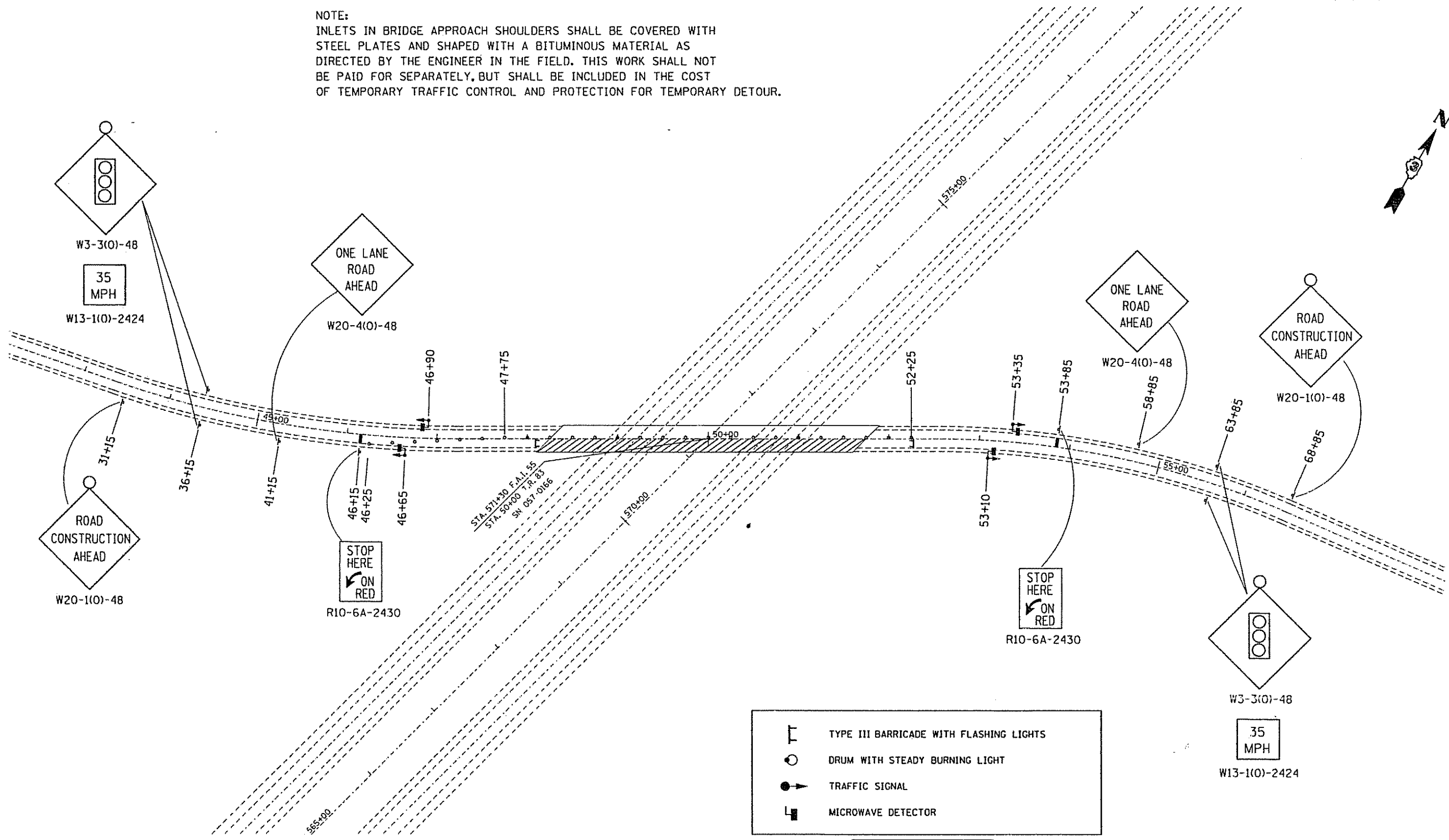
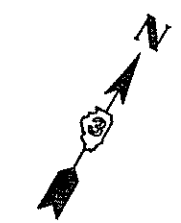
P.A.L. NO.	SECTION	COUNTY	SYMBOLS	SHEET NO.
55	#	McLEAN	139	51
STA.	TO STA.			
FED. ROAD DIST. NO.	BLANK	FED. ROAD PROJECT		
# 157-3-1.57-3.57-3-2.57-2RS				

NOTE:
 INLETS IN BRIDGE APPROACH SHOULDERS SHALL BE COVERED WITH STEEL PLATES AND SHAPED WITH A BITUMINOUS MATERIAL AS DIRECTED BY THE ENGINEER IN THE FIELD. THIS WORK SHALL NOT BE PAID FOR SEPARATELY, BUT SHALL BE INCLUDED IN THE COST OF TEMPORARY TRAFFIC CONTROL AND PROTECTION FOR TEMPORARY DETOUR.



-  TYPE III BARRICADE WITH FLASHING LIGHTS
-  DRUM WITH STEADY BURNING LIGHT
-  TRAFFIC SIGNAL
-  MICROWAVE DETECTOR

FOR ADDITIONAL DETAILS
 SEE STANDARD 701316





STAGE I
STAGING PLANS
 S.N. 057-0166

JAN. 13, 2000
 \ED021001\SHEETS.DGN

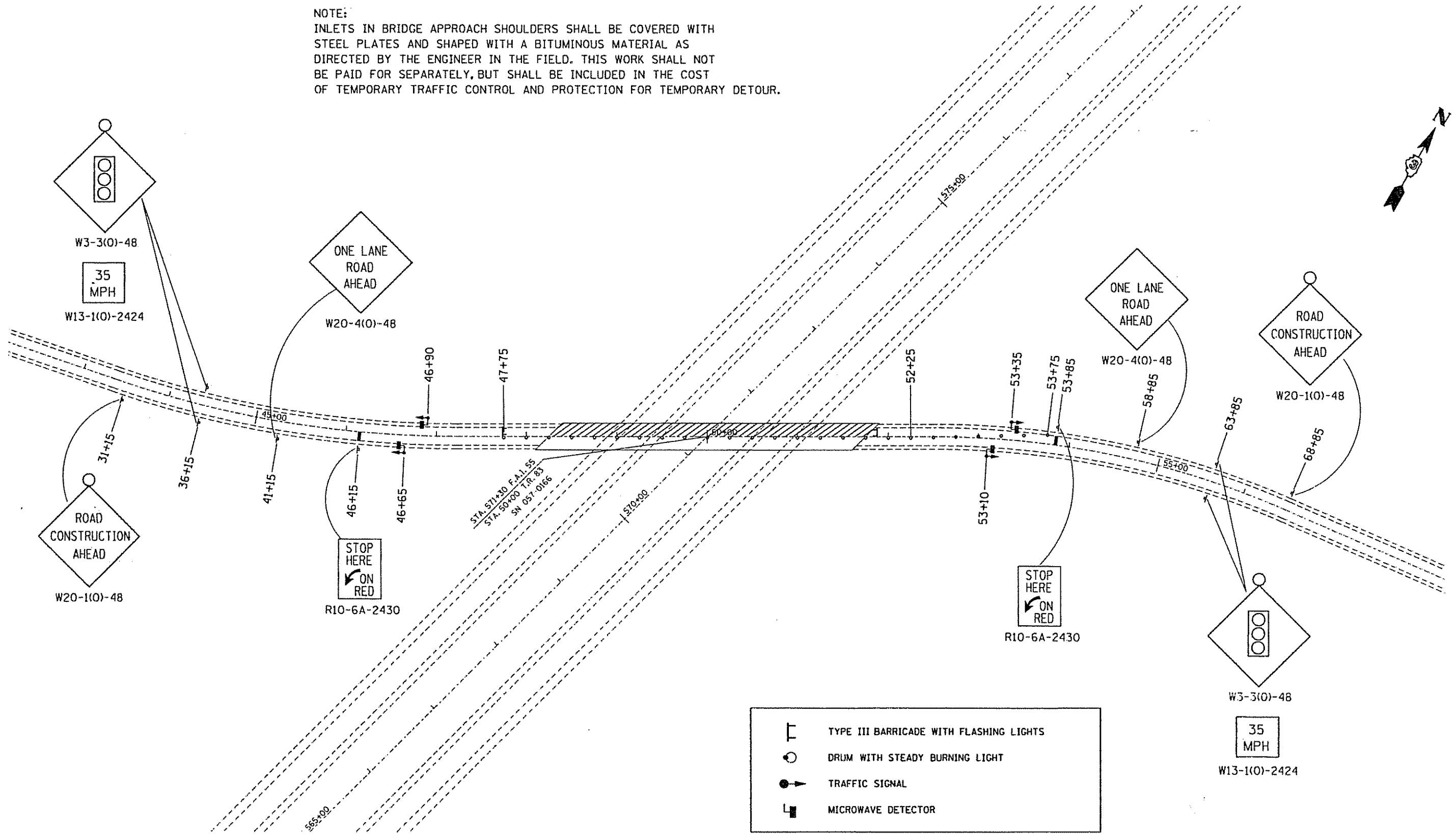
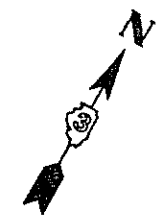
P.L. & S.	SECTION	COUNTY	DATE	NO.
55	D	McLEAN	1/3/9	52
STA.		TO STA.		
P.L. & S. INCL. IN		BLANKS	P.L. & S. PROJECT	
* 157-3-1.57-3.57-3-2.57-2MS				

NOTE:
 INLETS IN BRIDGE APPROACH SHOULDERS SHALL BE COVERED WITH STEEL PLATES AND SHAPED WITH A BITUMINOUS MATERIAL AS DIRECTED BY THE ENGINEER IN THE FIELD. THIS WORK SHALL NOT BE PAID FOR SEPARATELY, BUT SHALL BE INCLUDED IN THE COST OF TEMPORARY TRAFFIC CONTROL AND PROTECTION FOR TEMPORARY DETOUR.



-  TYPE III BARRICADE WITH FLASHING LIGHTS
-  DRUM WITH STEADY BURNING LIGHT
-  TRAFFIC SIGNAL
-  MICROWAVE DETECTOR

FOR ADDITIONAL DETAILS
 SEE STANDARD T01316

**STAGE II
 STAGING PLANS
 S.N. 057-0166**

JAN. 13, 2000
 \ED02100\SHEETS.DGN

SHOULDER REMOVAL & REPLACEMENT		
S. N.	STATIONS	
057-0167	583+37 TO 586+99,	589+76 TO 598+37
057-0168	578+37 TO 586+99,	589+76 TO 593+37

P.L. & L. NO.	SECTION	COUNTY	TOTAL SHEETS	SHEET NO.
55	8	MCLEAN	139	53
STA. TO STA.				
P.L. AND P.R. NO.		ALIGNED	P.L. AND P.R. NO.	
# 157-3-1.57-3.57-3-2.57-2WS				

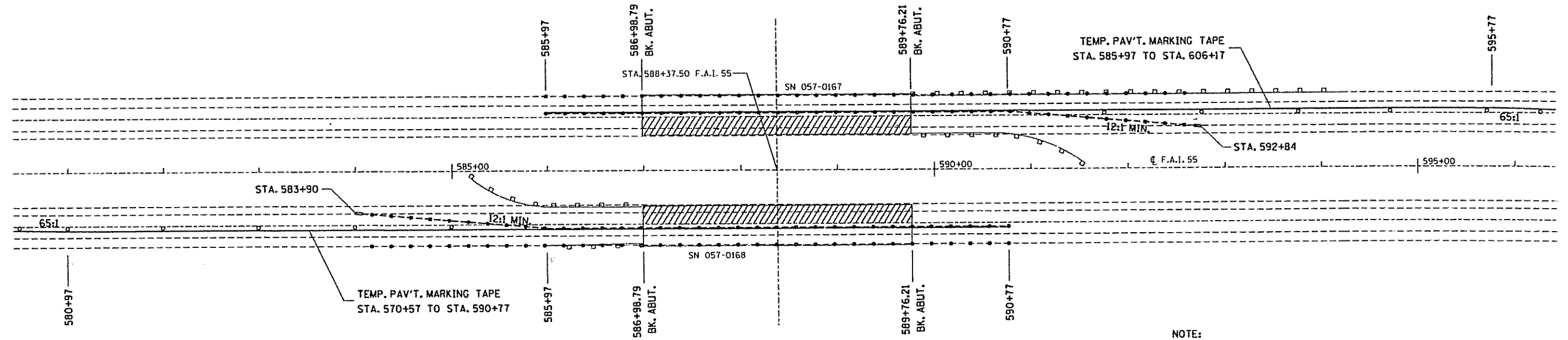

- NOTE:
1. OUTSIDE SHOULDERS SHALL BE REMOVED AND REPLACED PRIOR TO STAGE I CONSTRUCTION.
 2. MEDIAN SHOULDERS SHALL BE REMOVED AND REPLACED PRIOR TO STAGE II CONSTRUCTIONS.

STAGE I

	WORK AREA
	BI-DIRECTIONAL STEADY BURNING LIGHTS AND DOUBLE VERTICAL PANELS @ 20' CTS.
	DRUM WITH STEADY BURNING LIGHT
	TEMPORARY CONCRETE BARRIER
	TEMPORARY CONCRETE BARRIER TERMINAL SECTION

FOR ADDITIONAL DETAILS SEE STANDARD 701402

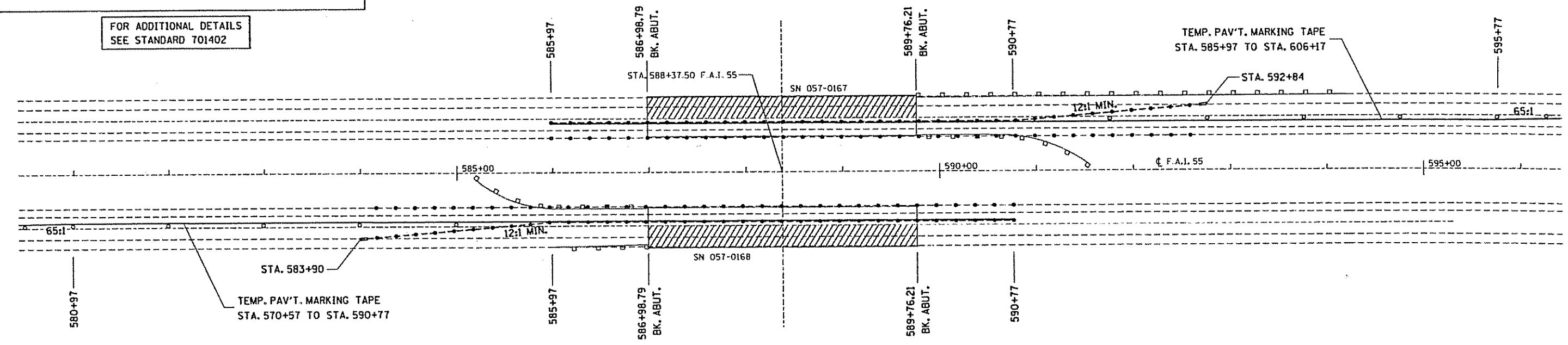

STAGE II STAGING PLANS

S.N. 057-0167 & S.N. 057-0168

SHOULDER REMOVAL & REPLACEMENT		
S. N.	STATIONS	
057-0169	603+50 TO 607+10,	609+60 TO 618+20
057-0170	598+50 TO 607+10,	609+60 TO 613+20

P.A.I. NO.	SECTION	COUNTY	TWP. RANGES	SHEET NO.
55		McLEAN	139	54
STA.		TO STA.		
POLYMER DATE		DATE	POL. NO. PROJECT	

157-3-1.57-3.57-3-2.57-2RS

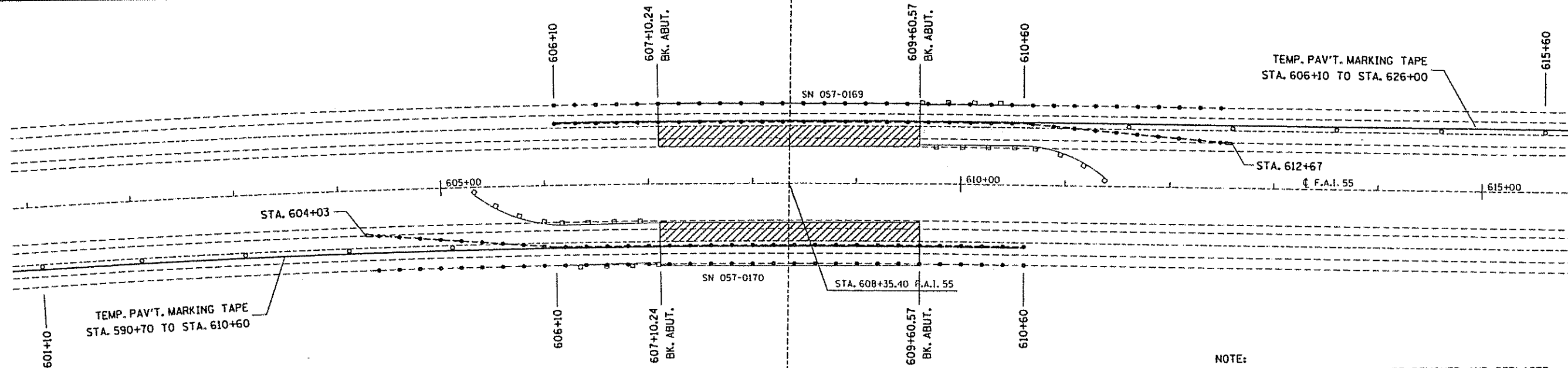

- NOTE:**
1. OUTSIDE SHOULDERS SHALL BE REMOVED AND REPLACED PRIOR TO STAGE I CONSTRUCTION.
 2. MEDIAN SHOULDERS SHALL BE REMOVED AND REPLACED PRIOR TO STAGE II CONSTRUCTIONS.

STAGE I

	WORK AREA
	BI-DIRECTIONAL STEADY BURNING LIGHTS AND DOUBLE VERTICAL PANELS @ 20' CTS.
	DRUM WITH STEADY BURNING LIGHT
	TEMPORARY CONCRETE BARRIER
	TEMPORARY CONCRETE BARRIER TERMINAL SECTION

FOR ADDITIONAL DETAILS SEE STANDARD 701402

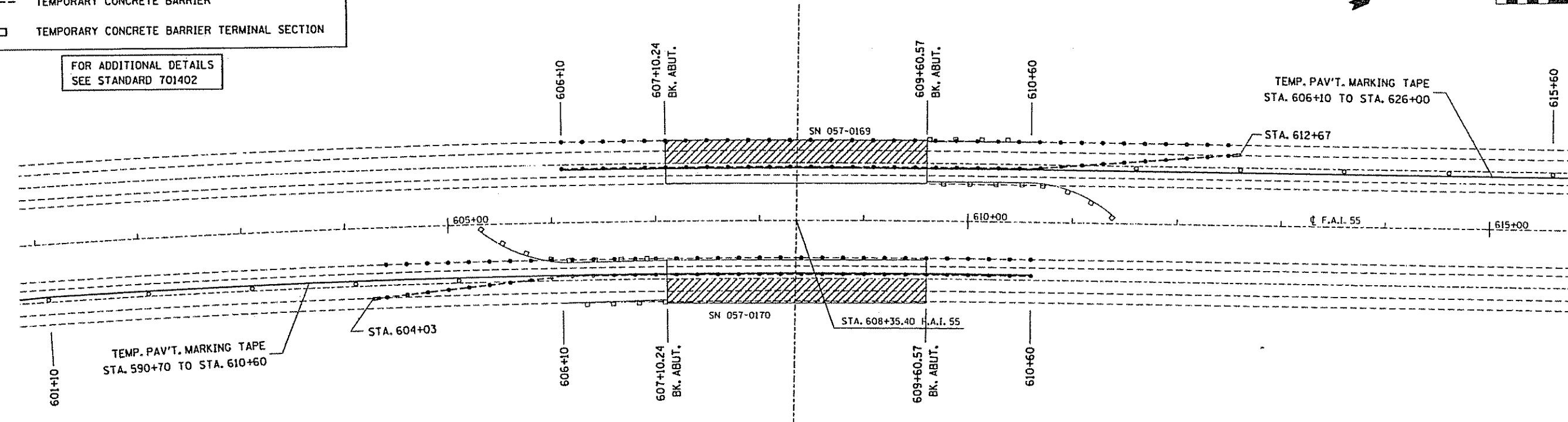

STAGE II STAGING PLANS

S.N. 057-0169 & S.N. 057-0170

JAN. 11, 2000
\\ED021001\SHEETS.DGN

F.A.I. RTE. 55	SECTION •	COUNTY MCLEAN	TOTAL SHEETS 139	SHEET NO. 55
STA. 259+36.01		TO STA.		
FED. ROAD DIST. NO.		ILLINOIS	FED. AID PROJECT	
• 57-3-1, 57-3, 57-3-2, 57-21 RS				

SHEET 1 of 7

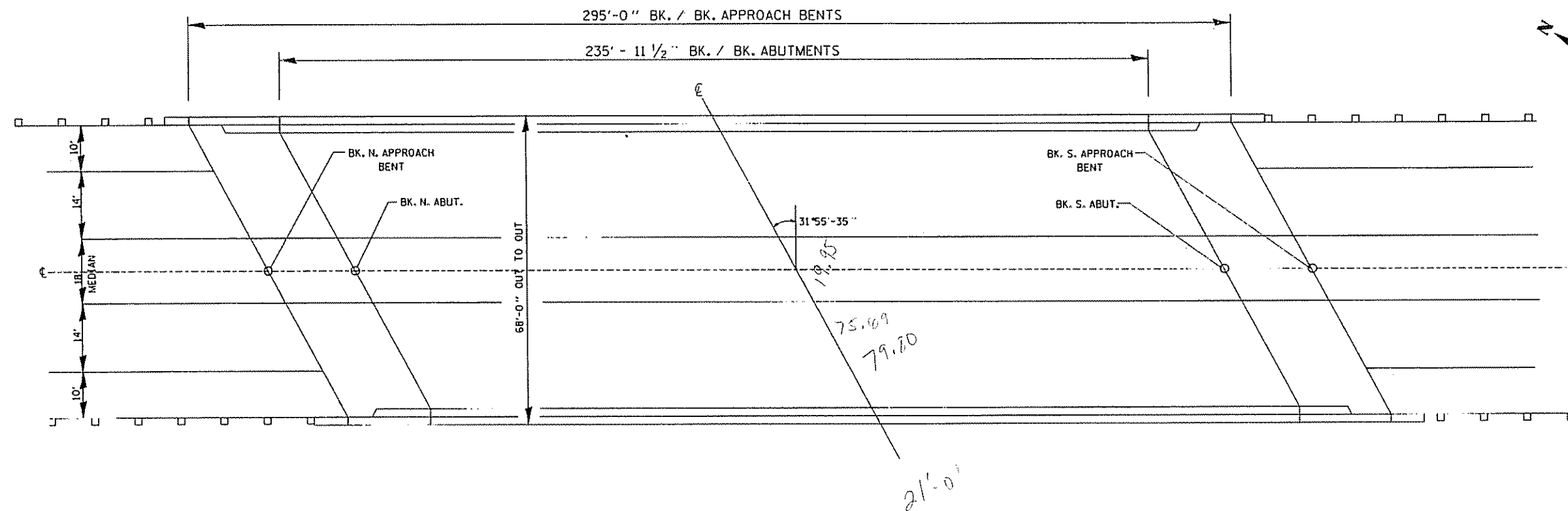

S.N. 057-0162

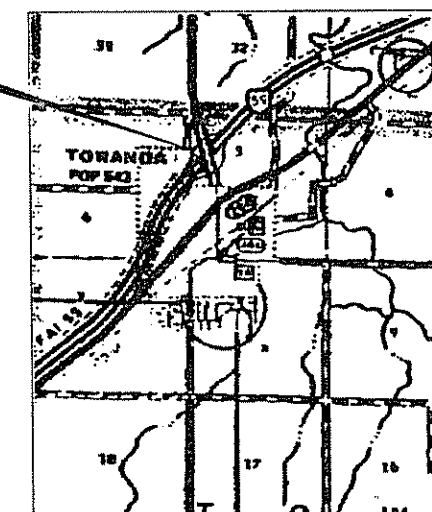

LOCATION SKETCH

NOTE:
SEE SHEET 2 OF 7 FOR GENERAL NOTES.

TOTAL BILL OF MATERIALS S.N. 057-0162

CODE NO.	ITEM	UNIT	QUANT.
28100105	STONE RIPRAP, CLASS A3	SQ YD	44
28200100	FILTER FABRIC FOR USE WITH RIPRAP	SQ YD	44
44001000	BITUMINOUS CONCRETE REMOVAL (DECK)	SQ YD	1245
50102400	CONCRETE REMOVAL	CU YD	14
50300255	CONCRETE SUPERSTRUCTURE	CU YD	16
50300300	PROTECTIVE COAT	SQ YD	45
50301245	FORMED CONCRETE REPAIR (DEPTH LESS THAN OR EQUAL TO 5")	SQ FT	48
50500405	FURNISHING AND ERECTING STRUCTURAL STEEL	POUND	5844
50800205	REINFORCEMENT BARS, EPOXY COATED	POUND	3280
58100200	WATERPROOFING MEMBRANE SYSTEM	SQ YD	1230
59000100	EPOXY CRACK SEALING	FOOT	159
X0321468	PLUG EXISTING DECK DRAINS	EACH	4
X0321744	SILICONE JOINT SEAL - 2"	FOOT	159
X4066528	BIT. CONC. SURF. CSE., SUPERPAVE, MIX "D"; N90	TON	107
Z0002600	BAR SPLICERS	EACH	30
Z0016001	DECK SLAB REPAIR (FULL DEPTH, TYPE I)	SQ YD	1
Z0016200	DECK SLAB REPAIR (PARTIAL)	SQ YD	6
Z0047300	PROTECTIVE SHIELD	SQ YD	756

Handwritten notes: 11-2-2000

GENERAL PLAN
CH. 29 OVER F.A.I. 55
SECTION (57-3-1, 57-3, 57-3-2, 57-2) RS
MCLEAN COUNTY
STA. 259+36.01
S.N. 057-0162

F.A.I. RTE.	SECTION	COUNTY	TOTAL SHEETS	SHEET NO.
55	*	MCLEAN	139	56
STA.		TO STA.		
FED. ROAD DIST. NO.		ILLINOIS	FED. AID PROJECT	
* 57-3-1, 57-3, 57-3-2, 57-21 RS				

SHEET 2 of 7

General Notes:

- All structural steel shall conform to AASHTO Classification M-270 Gr. 36 unless otherwise noted.
- All Structural steel shall be shop painted with Inorganic zinc rich primer per AASHTO M300, Type 1. The cost shall be Included in the cost of Furnishing and Erecting Structural Steel.
- The existing structural steel contains lead. The Contractor should take appropriate precautions to deal with the presence of lead on this project.
- Reinforcement bars shall conform to the requirements of AASHTO M-31, M-42 or M-53 Grade 60.
- Any reinforcement bars that are damaged during concrete removal shall be replaced with an approved bar splicer or anchorage system. Cost shall be Included in the cost of "Concrete Removal".
- Existing longitudinal reinforcement extending into the removed area shall be cleaned, straightened and incorporated into the new construction. Existing transverse reinforcement may be cut as shown and removed.
- Prior to pouring the new concrete for the deck, all loose rust, loose mill scale and all other loose, detrimental foreign material shall be removed from the portions of flanges of beams in contact with concrete. The removal shall be accomplished according to the requirements of the SSPC Surface Preparation Specifications SP-3 for power tool cleaning or SP-2 for hand tool cleaning. Cost shall be Included in the cost of "Concrete Superstructure".
- Joint openings shall be adjusted according to Article 503.10(c) of the Standard Specifications when the deck is poured at an ambient temperature other than 50 degrees Fahrenheit.
- Plan dimensions and details relative to existing structure have been taken from existing plans and are subject to nominal construction variations. It shall be the Contractor's responsibility to verify such dimensions and details in the field and make necessary approved adjustments prior to construction or ordering of materials. Such variations shall not be cause for additional compensation for a change in the scope of the work, however, the Contractor will be paid for the quantity actually furnished at the unit price bid for the work.

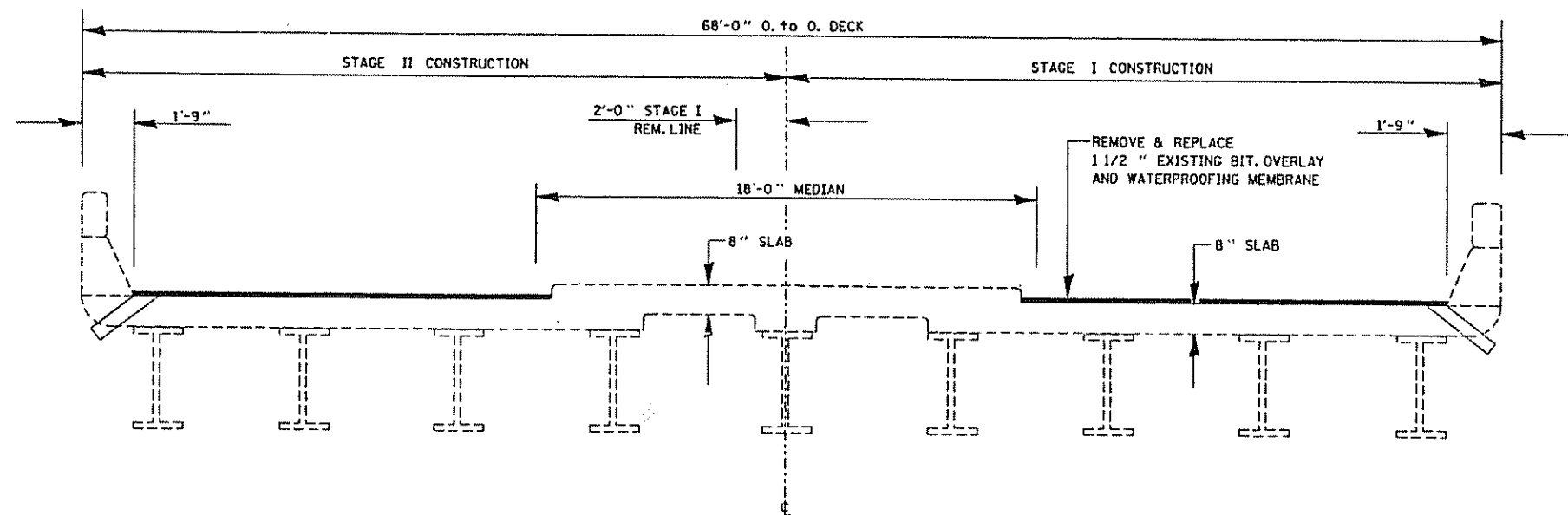

CROSS SECTION
LOOKING NORTH

GENERAL NOTES AND TYPICAL SECTION
CH. 29 OVER F.A.I. 55
SECTION (57-3-1, 57-3, 57-3-2, 57-2) RS
MCLEAN COUNTY
STA. 259+36.01
S.N. 057-0162

DEC. 23, 1999
VED02TOD/ETA/LS.DGN

F.A.I. RTE.	SECTION	COUNTY	TOTAL SHEETS	SHEET NO.
55	♦	MCLEAN	139	57
STA.	TO STA.			
FED. ROAD DIST. NO.	ILLINOIS	FED. AID PROJECT		
♦ 157-3-1, 57-3, 57-3-2, 57-21 RS				
SHEET 3 of 7				

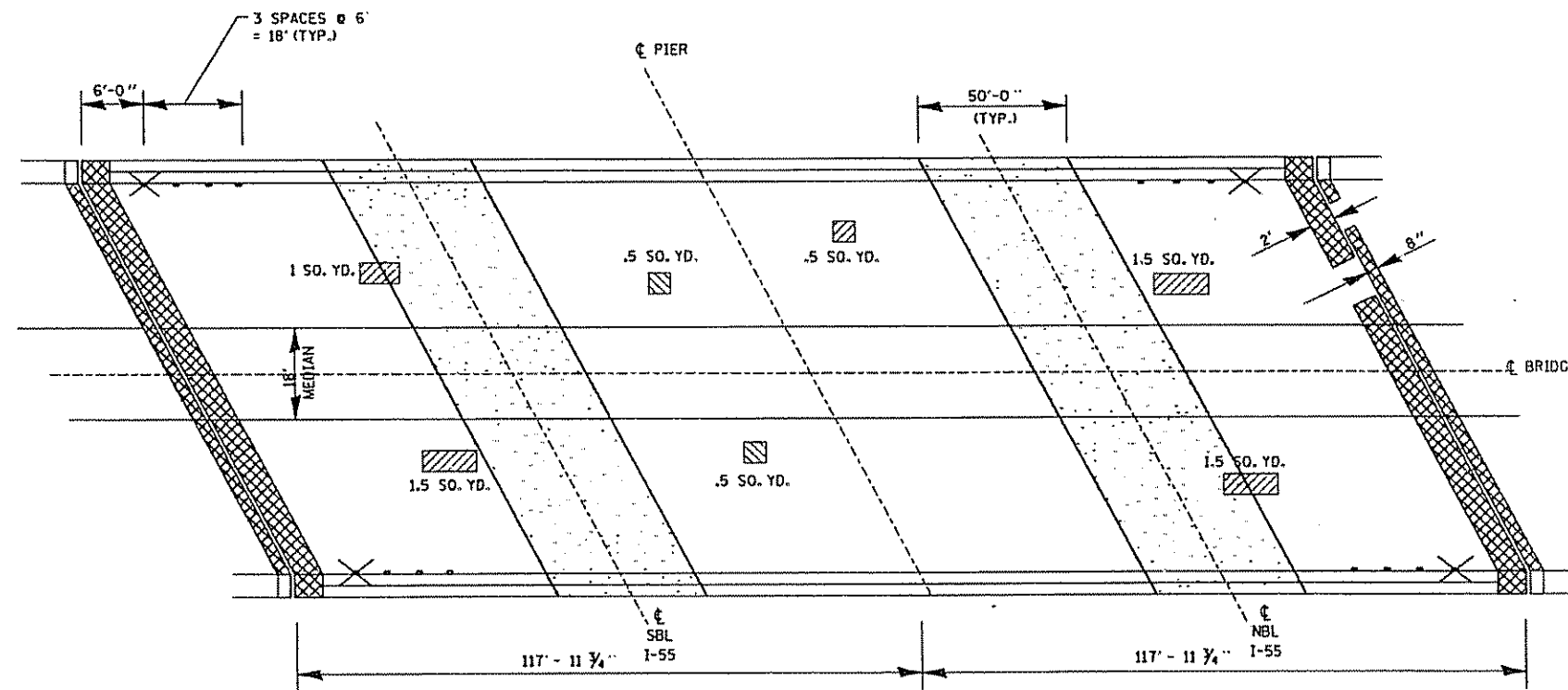

NOTES:

AREA OF DECK REPAIRS SHOWN ARE ESTIMATED. THE ENGINEER SHALL SHOW ACTUAL LOCATIONS OF DECK REPAIRS ON AS-BUILT PLANS.

EXISTING DECK DRAINS LOCATED WITHIN 10 FT. OF A PIER OR AN ABUTMENT SHALL BE ELIMINATED.

DECK REPAIR PLAN

	UNIT	STAGE I	STAGE II	TOTAL
CONC. REMOVAL	CU. YD.	7.4	6.6	14
CONC. SUPERSTRUCTURE	CU. YD.	8	8	16
PLUG EXISTING DECK DRAINS	EACH	2	2	4
DECK SLAB REPAIR (PARTIAL DEPTH)	SO. YD.	3	3	6
DECK SLAB REPAIR (FULL DEPTH)	SO. YD.	.5	.5	1
PROTECTIVE SHIELD	SO. YD.	378	378	756

DECK SURVEY DATE: FEBRUARY 9, 1999

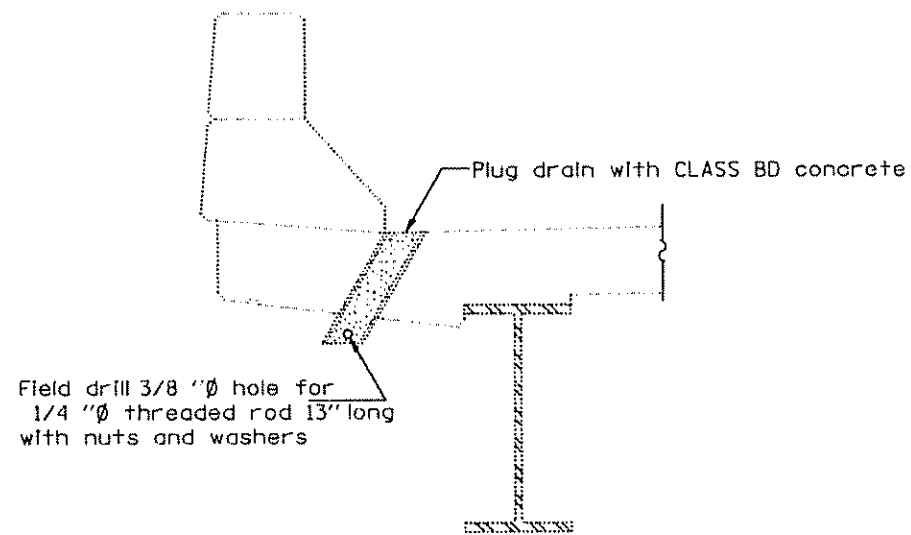

SECTION AT DRAIN
DRAIN ELIMINATION DETAILS

DECK REPAIR PLAN
CH. 29 OVER F.A.I. 55
SECTION (57-3-1, 57-3, 57-3-2, 57-2) RS
MCLEAN COUNTY
STA. 259+36.01
S.N. 057-0162

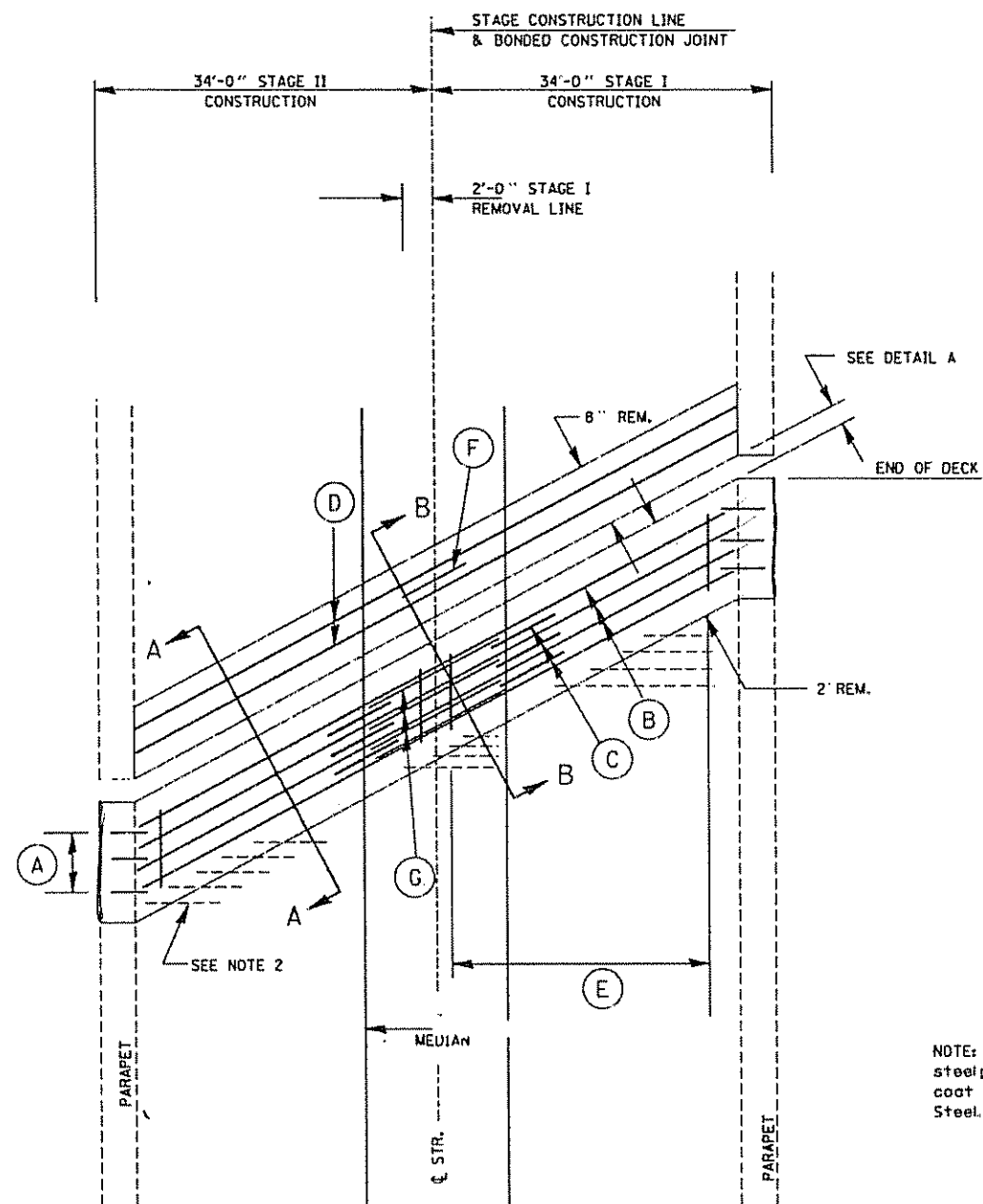

**PLAN AT NORTH ABUTMENT
(SOUTH ABUTMENT MIRROR IMAGE)**

BARS REQUIRED FOR EACH STAGE

- (A) 3- #4 d (E) Bars
3- #5 d₁(E) Bars
2- #4 d₃(E) Bars @ ea. rail post
3- #6 a₁(E) Bars (Top)
(Lap with a (E) Bars)
- (B) 4x2- #6 a (E) Bars (Top)
4x2- #6 a (E) Bars (Bottom)
- (C) 4- #5 a (E) Bars @ 7/2" ctrs.
- (D) 2x2- #6 a (E) Bars (Top)
- (E) 33- #5 d₄(E) Bars @ 12" ctrs.
- (F) 1- #5 a₂(E) Bar (Top of Median)
- (G) 4- #5 a₂(E) Bars @ 7/2" ctrs.
(Top of Median)

Min Bar Lap
#6 Bar 2'-7"

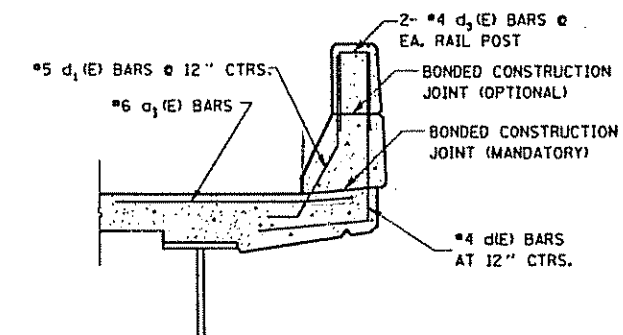

**SECTION THRU PARAPET
(DECK SIDE)**

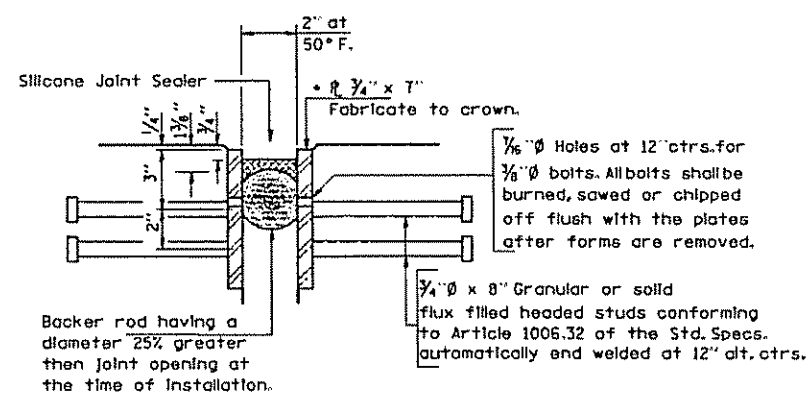

NOTE: After fabrication all surfaces of the steel plates shall be given one shop coat of paint specified for Structural Steel. No field painting required.

• Furnish in segments of 20 ft. maximum length. Maximum space between installed segments shall be 1/8". Seal space with Silicone Sealant suitable for Structural Steel.

**SILICONE JOINT SEALER
DETAIL A**

BILL OF MATERIAL		SN 057-0162		
BAR	NO.	SIZE	LENGTH (FT.)	SHAPE
a(E)	80	#6	21'-0"	—
a1(E)	12	#6	4'-0"	—
a2(E)	20	#5	9'-4"	—
c(E)	16	#5	3'-1"	—
d(E)	12	#4	4'-9"	—
d1(E)	12	#5	3'-7"	—
d3(E)	8	#4	2'-1"	—
d4(E)	132	#5	2'-6"	—
CONCRETE REMOVAL		CU YD	14	
CONC. SUPERSTRUCTURE		CU YD	16	
BAR SPLICERS		EACH	30	
REINFORCEMENT BARS, EPOXY COATED		POUND	3280	

REINFORCEMENT BARS DESIGNATED (E) SHALL BE EPOXY COATED

**EXPANSION JOINT REPLACEMENT DETAILS
CH. 29 OVER F.A.I. 55
SECTION (57-3-1, 57-3, 57-3-2, 57-2) RS
MCLEAN COUNTY
STA. 259+36.01
S.N. 057-0162**

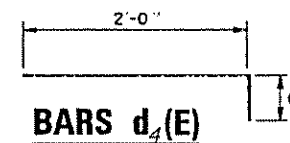
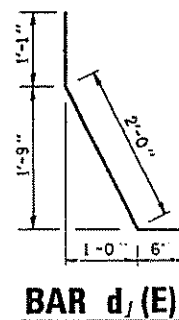
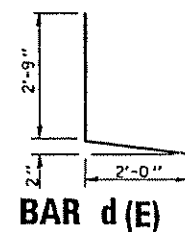
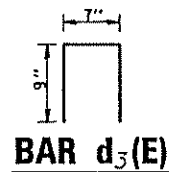
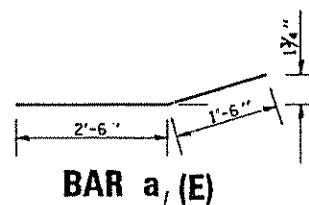
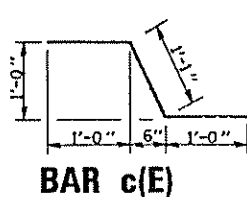

F.A.I. RTE.	SECTION	COUNTY	TOTAL SHEETS	SHEET NO.
55	•	MCLEAN	139	59
STA.	TO STA.			
FED. ROAD DIST. NO.	ILLINOIS	FED. AID PROJECT		
• 57-3-1, 57-3, 57-3-2, 57-2) RS				
SHEET 5 of 7				

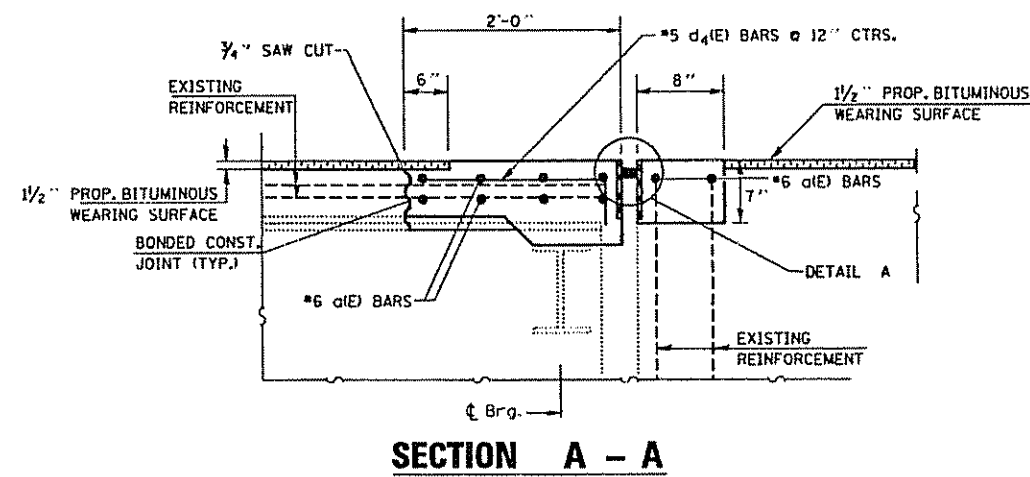

SECTION A - A

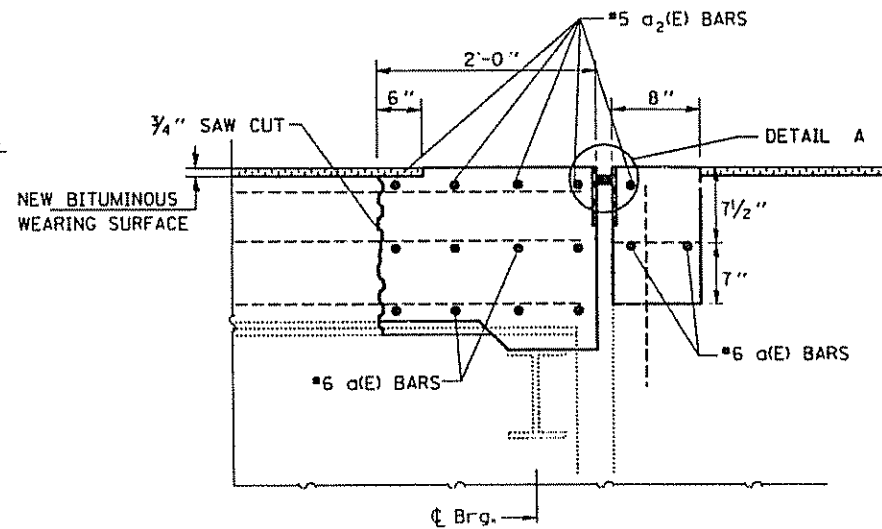

SECTION B - B

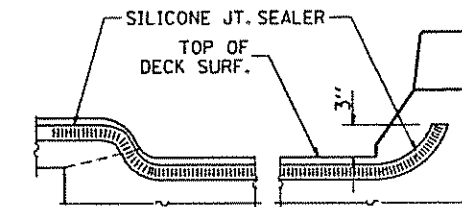

TYPICAL END OF SEAL TREATMENT

NOTES:

1. THE LIMITS OF ALL CONCRETE REMOVAL SHALL BE SAW CUT 3/4" INTO CONCRETE.
2. EXISTING TRANSVERSE BARS EXTENDING FROM DECK INTO REMOVED AREA SHALL BE CUT ALLOWING 2'-0" TO EXTEND INTO THE REMOVED AREA. IN ADDITION, THESE CUT BARS SHALL BE CLEANED, STRAIGHTENED, AND INCORPORATED INTO THE NEW CONSTRUCTION
3. EXISTING LONGITUDINAL BARS IN DECK AND VERTICAL BARS IN ABUTMENT BACKWALL EXTENDING INTO THE REMOVED AREA SHALL BE CLEANED, STRAIGHTENED, AND INCORPORATED IN THE NEW WORK.
4. EXISTING PARAPET REINFORCEMENT EXTENDING INTO THE REMOVED AREA SHALL BE CLEANED, STRAIGHTENED AND INCORPORATED INTO THE NEW CONSTRUCTION.
5. THE REMOVAL AND REPLACEMENT OF CONCRETE AT THE ABUTMENT BACKWALL, PARAPET, AND DECK WILL BE PAID FOR AS CONCRETE REMOVAL AND CONCRETE SUPERSTRUCTURE.
6. THE PARAPET SHALL BE REMOVED ON THE DECK SIDE, BUT SHALL REMAIN IN PLACE ON THE ABUTMENT SIDE. CONCRETE REMOVAL AT THE ABUTMENT SHALL BE FROM FACE OF PARAPET TO FACE OF PARAPET.
7. THE REMOVAL OF EXISTING PJS AND STEEL ARMOUR SHALL BE INCLUDED IN THE COST OF "CONCRETE REMOVAL".

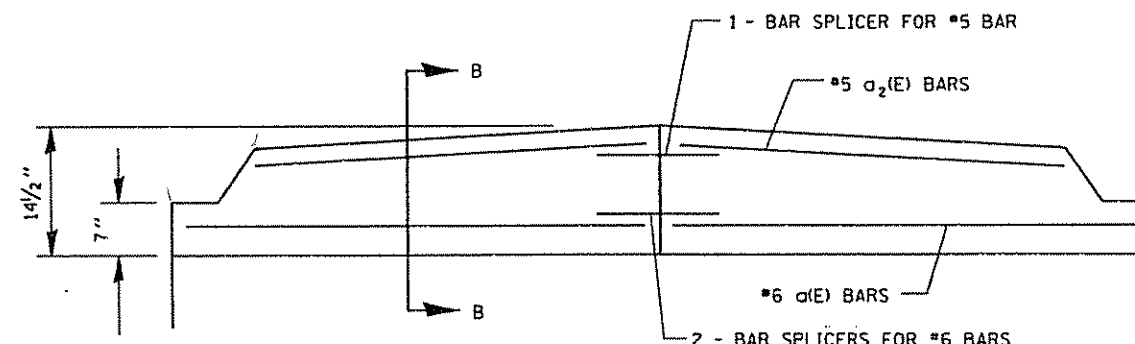

SECTION THRU MEDIAN (APPROACH)

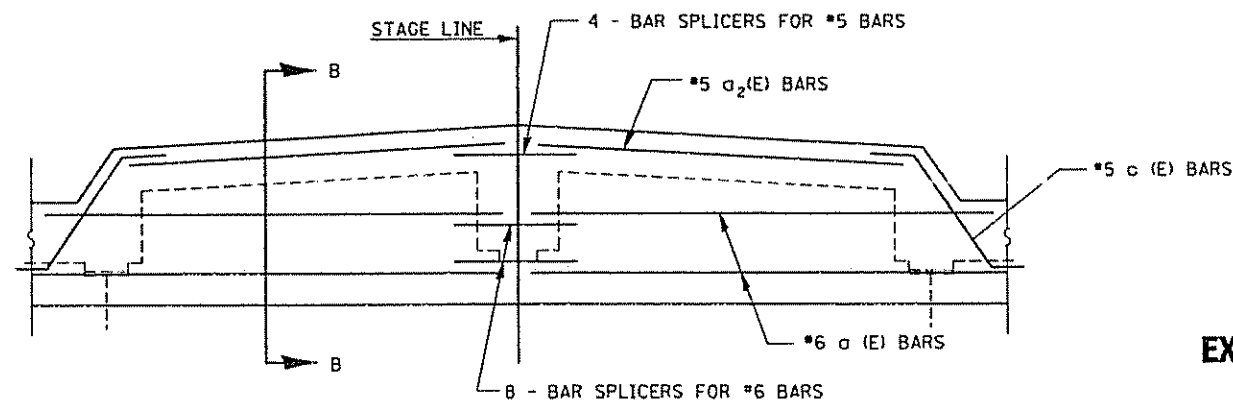

SECTION THRU MEDIAN (DECK)

EXPANSION JOINT REPLACEMENT DETAILS
CH. 29 OVER F.A.I. 55
SECTION (57-3-1, 57-3, 57-3-2, 57-2) RS
MCLEAN COUNTY
STA. 259+36.01
S.N. 057-0162

F.A.I. RTE.	SECTION	COUNTY	TOTAL SHEETS	SHEET NO.
55	*	MCLEAN	139	60

STA. TO STA.
 FED. ROAD DIST. NO. ILLINOIS FED. AID PROJECT
 * (57-3-1, 57-3, 57-3-2, 57-2) RS

SHEET 6 of 7

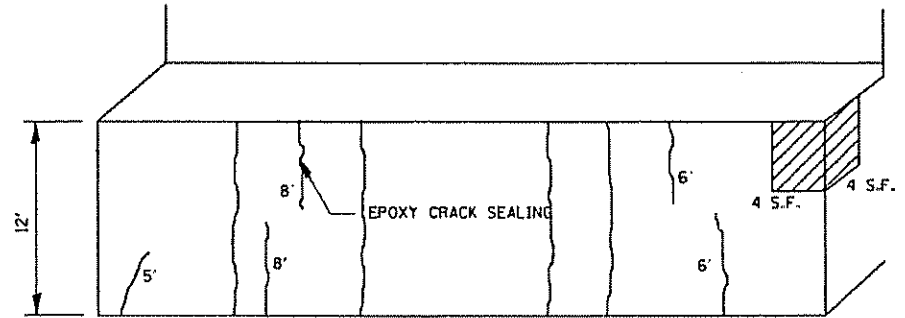

NORTH ABUTMENT
 EPOXY CRACK SEALING = 81'

FORMED CONCRETE
 REPAIR ≤ 5"
 8 S.F.

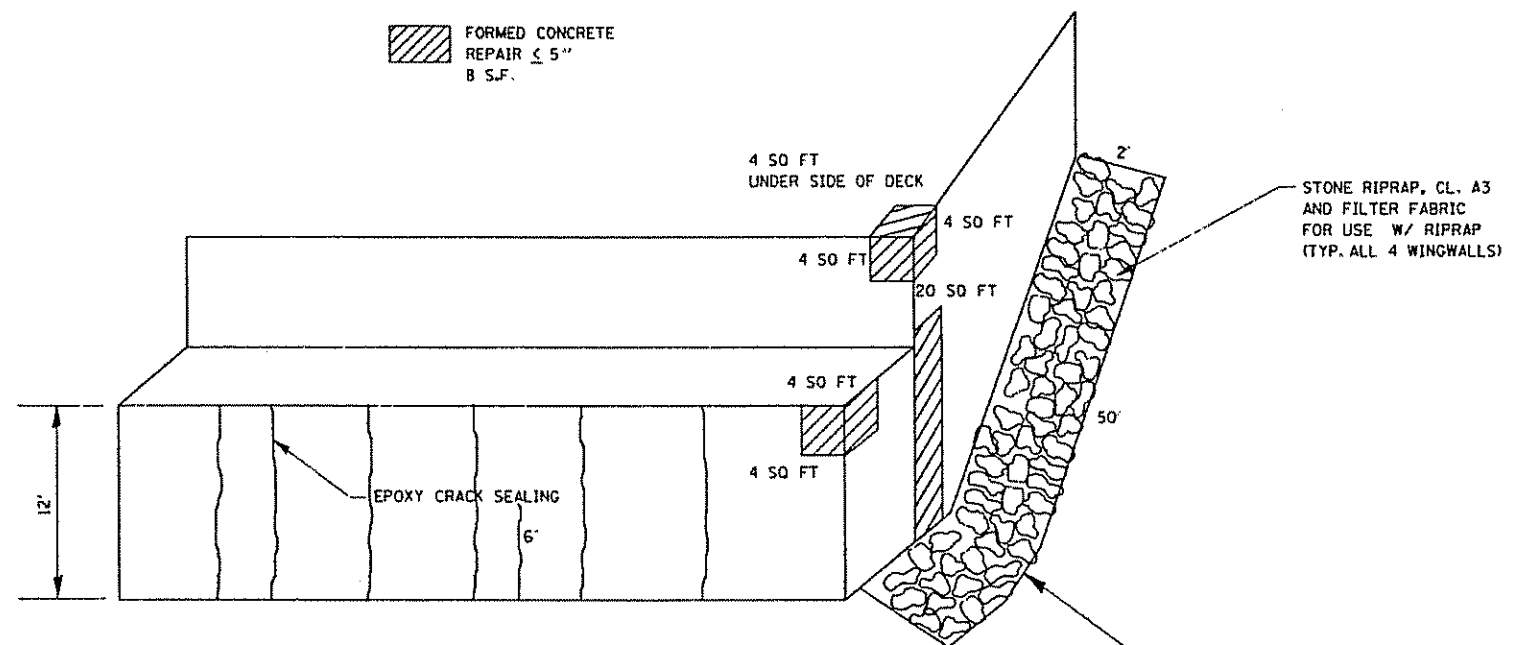

SOUTH ABUTMENT
 EPOXY CRACK SEALING = 78'

FORMED CONCRETE
 REPAIR ≤ 5" = 48 S.F.

EPOXY CRACK SEALING = 159'
 FORMED CONCRETE
 REPAIR ≤ 5" = 48 S.F.
 RIPRAP = 400 SO FT = 44 SO. YD.

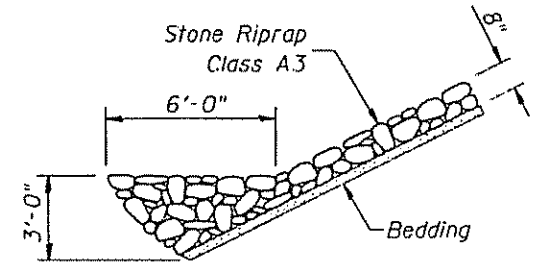

STONE RIPRAP ANCHOR DETAIL

ABUTMENT CRACKS AND SPALLS
 S.N. 057-0162

ABUTMENT REPAIRS
 CH. 29 OVER F.A.I. 55
 SECTION (57-3-1, 57-3, 57-3-2, 57-2) RS
 MCLEAN COUNTY
 STA. 259 + 36.01
 S.N. 057-0162

STATE OF ILLINOIS
DEPARTMENT OF TRANSPORTATION

PROJECT NO.	SECTION	DATE	BY	CHKD	SHEET NO. 7
					7 SHEETS
MCCLEAN		139	61		
* 57-3-1,57-3,57-3-2,57-2RS					

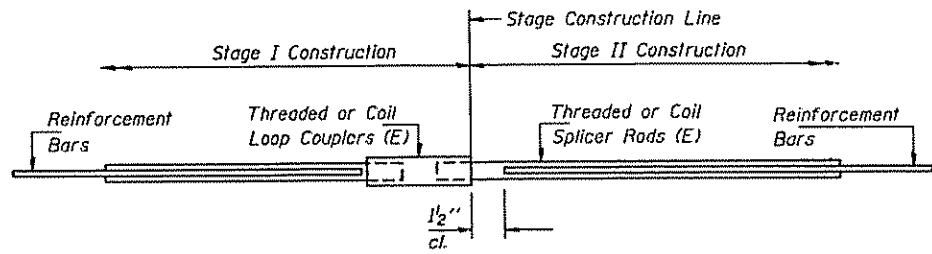

SPLICER DETAIL

Bar Size	No. Assemblies Required	Location
#5	10	Stage Construction Line
#6	20	Stage Construction Line
Total	30	

The diameter of this part is equal or larger than the diameter of bar spliced.

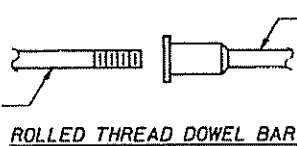

ROLLED THREAD DOWEL BAR



ONE PIECE

Wire Connector



WELDED SECTIONS

BAR SPLICER ASSEMBLY ALTERNATIVES

** Heavy Hex Nuts conforming to ASTM A 563, Grade C, D or DH may be used.

NOTES

Bar splicer assemblies shall be of an approved type and shall develop in tension at least 125 percent of the yield strength of the lapped reinforcement bars.

Splicer rods shall be of minimum 60 ksi yield strength, threaded or coiled full length. All reinforcement bars shall be lapped and tied to the splicer rods or dowel bars. Bar splicer assemblies shall be epoxy coated according to the requirements for reinforcement bars.

Other systems of similar design may be submitted to the Engineer for approval. Approval shall be based on certified test results from an approved testing laboratory that the proposed bar splicer assembly satisfies the following requirements:

- ① Minimum Capacity = $1.25 \times f_y \times A_t$
(Tension in kips)
- ② Minimum Pull-out Strength = $1.25 \times f_{s_{allow}} \times A_t$
(Tension in kips)

Where f_y = Yield strength of lapped reinforcement bars in ksi.
 $f_{s_{allow}}$ = Allowable tensile stress in lapped reinforcement bars in ksi (Service Load)
 A_t = Tensile stress area of lapped reinforcement bars.
 * = 28 day concrete

Bar Size to be Spliced	Splicer Rod or Dowel Bar Length	Strength Requirements	
		Min. Capacity kips - tension	Min. Pull-Out Strength kips - tension
#5	2'-0"	23.0	9.2
#6	2'-7"	33.1	13.3
#7	3'-5"	45.1	18.0
#8	4'-6"	58.9	23.6

Bar splicer assemblies shall be according to Section 508 of the Standard Specifications except as noted. The furnishing and installation of bar splicer assemblies will be measured and paid for at the contract unit price each for "BAR SPLICERS."

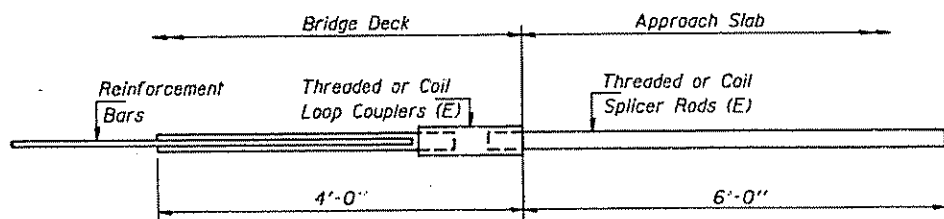

**INTEGRAL ABUTMENT
BAR SPLICER ASSEMBLY DETAIL
FOR #5 BAR**

Min. Capacity = 23.0 kips - tension
Min. Pull-out Strength = 9.2 kips - tension
No. Required =

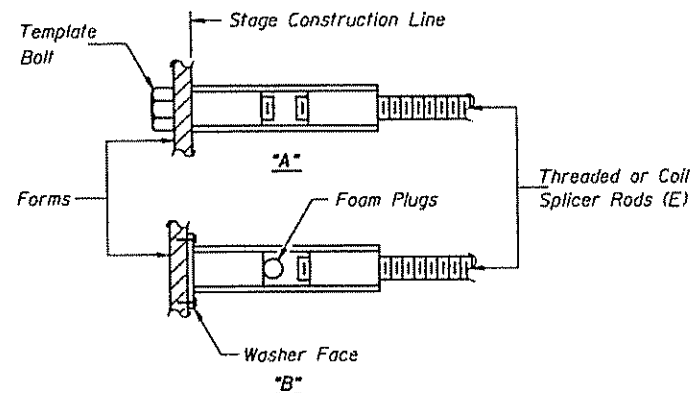

INSTALLATION AND SETTING METHODS

"A" : Set bar splicer assembly by means of a template bolt.
 "B" : Set bar splicer assembly by nailing to wood forms or cementing to steel forms.
 (E) : Indicates epoxy coating.

DESIGNED	20
CHECKED	
DRAWN	
CHECKED	

EXAMINED	
PASSED	

BSD-1 4-30-99

BAR SPLICER ASSEMBLY DETAILS
CH. 29 OVER F.A.I. 55
SECTION (57-3-1,57-3,57-3-2,57-2) RS
McCLEAN COUNTY
STA. 259 + 36.01
SN 057-0162

F.A.I. RTE.	SECTION	COUNTY	TOTAL SHEETS	SHEET NO.
55	*	MCLEAN	139	62
STA.		TO STA.		
FED. ROAD DIST. NO.		ILLINOIS FED. AID PROJECT		
• 57-3-1, 57-3, 57-3-2, 57-2) RS				

SHEET 1 of 15

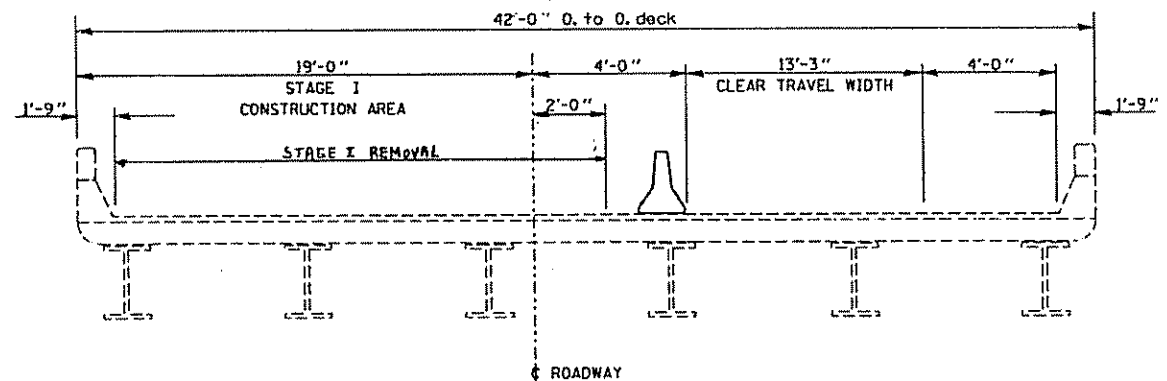
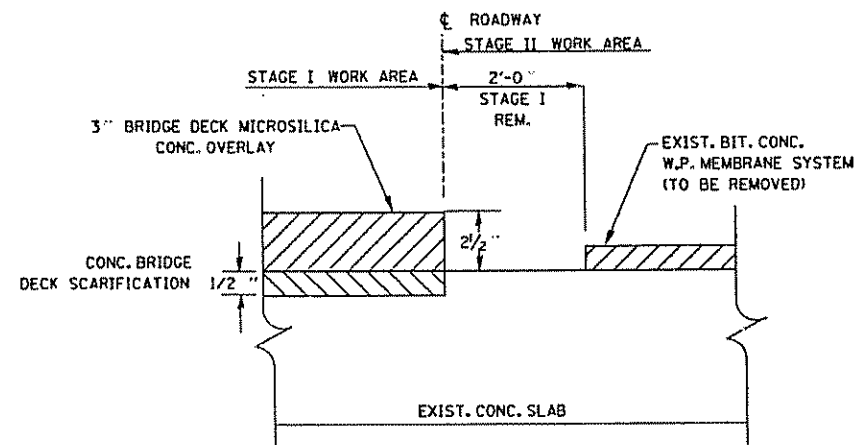

STAGE I
LOOKING SOUTH

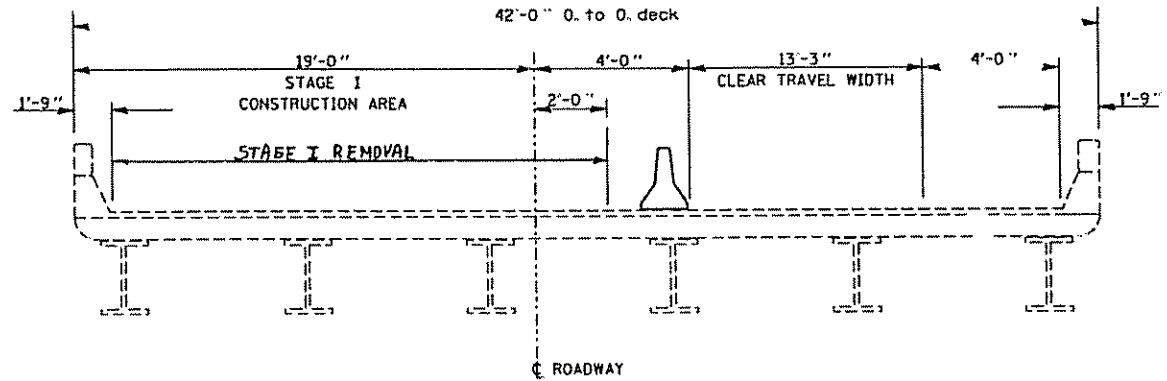

STAGE I
LOOKING NORTH

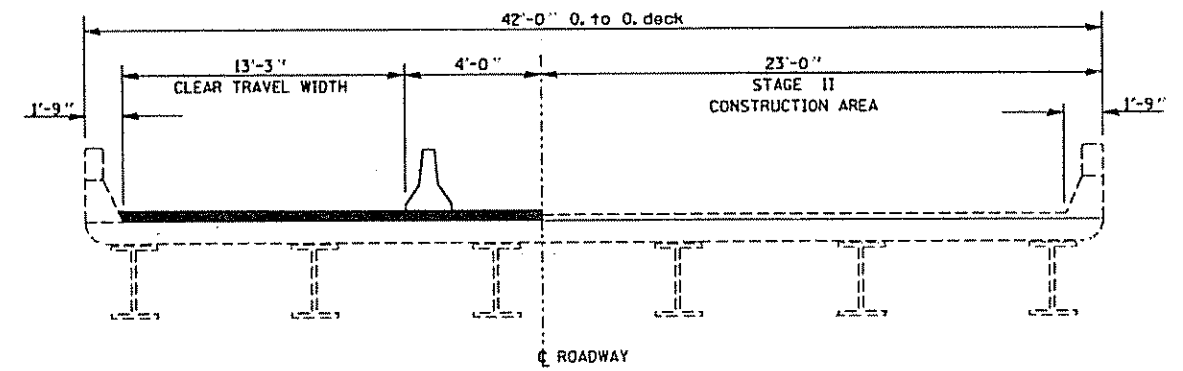

STAGE II
LOOKING SOUTH

STAGE CONSTRUCTION DIAGRAM

S.N. 057-0163

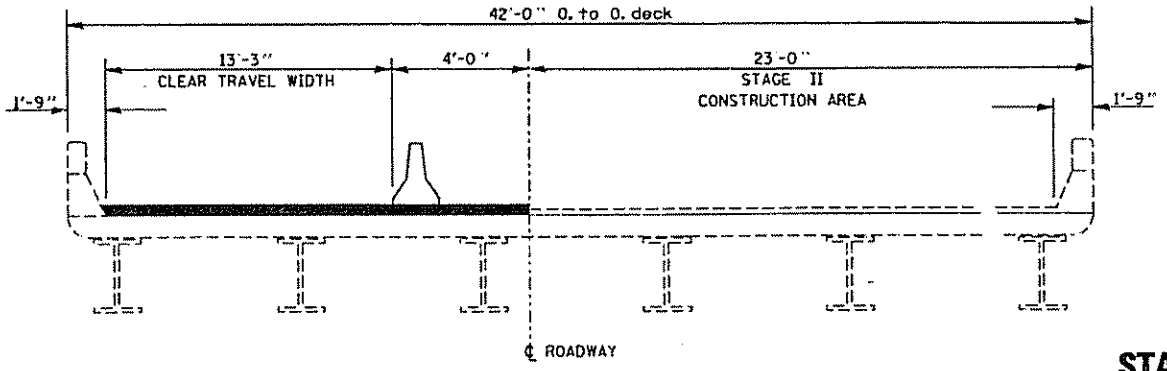

STAGE II
LOOKING NORTH

STAGE CONSTRUCTION DIAGRAM

S.N. 057-0164

STAGING DETAILS
F.A.I. 55 OVER MONEY CREEK
SECTION (57-3-1, 57-3, 57-3-2, 57-2) RS
MCLEAN COUNTY
STA. 322 + 95
S.N. 057-0163 & S.N. 057-0164

DEC. 23, 1999
VED02100\DETAILS.DGN

F.A.I. RTE.	SECTION	COUNTY	TOTAL SHEETS	SHEET NO.
55		MCLEAN	139	63
STA.		TO STA.		
FED. ROAD DIST. NO.		ILLINOIS	FED. AID PROJECT	
		• (57-3-1, 57-3, 57-3-2, 57-2) RS		

SHEET 2 of 15

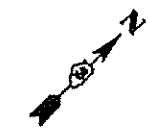
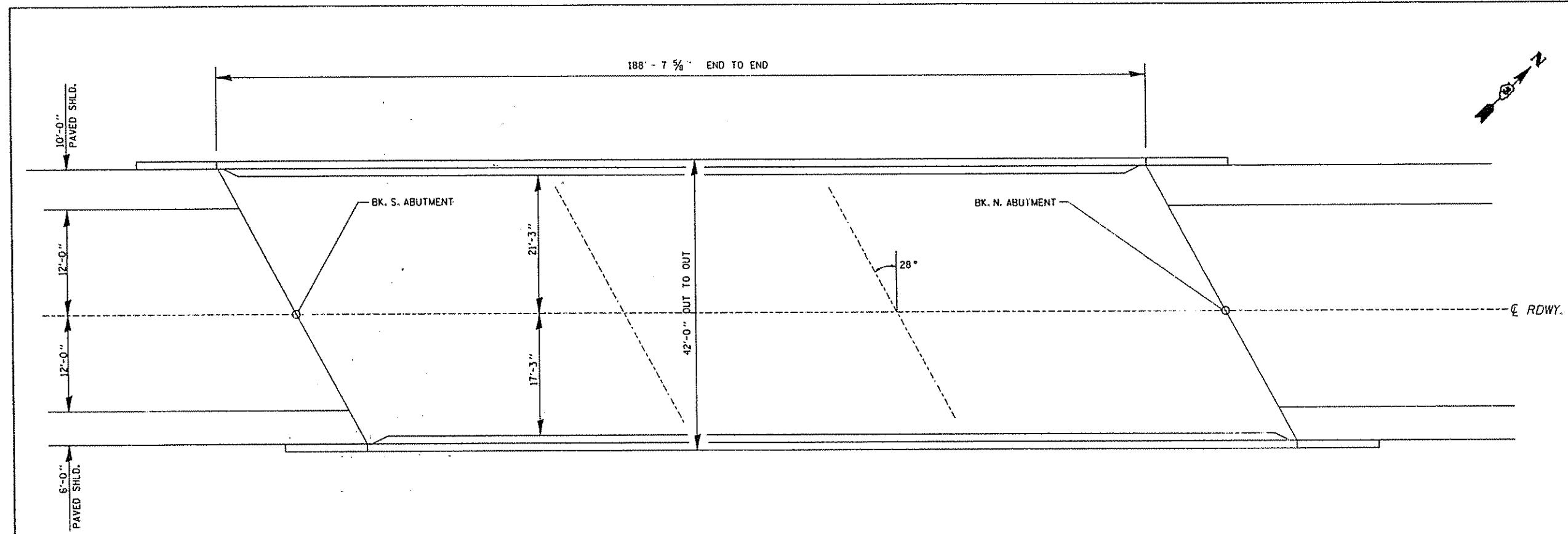

TOTAL BILL OF MATERIALS S.N. 057-0163			
CODE NO.	ITEM	UNIT	QUANT.
20300100	CHANNEL EXCAVATION	CU YD	500
28100105	STONE RIPRAP, CLASS A3	SQ YD	11
28100107	STONE RIPRAP, CLASS A4	SQ YD	143
28200100	FILTER FABRIC FOR USE WITH RIPRAP	SQ YD	167
44001000	BITUMINOUS CONCRETE REMOVAL (DECK)	SQ YD	807
50102400	CONCRETE REMOVAL	CU YD	6
50300255	CONCRETE SUPERSTRUCTURE	CU YD	6
50300260	BRIDGE DECK GROOVING	SQ YD	765
50300300	PROTECTIVE COAT	SQ YD	823
50301245	FORMED CONCRETE REPAIR (DEPTH LESS THAN OR EQUAL TO 5")	SQ FT	84
50500405	FURNISHING AND ERECTING STRUCTURAL STEEL	POUND	3385
50800205	REINFORCEMENT BARS, EPOXY COATED	POUND	1859
59000100	EPOXY CRACK SEALING	FOOT	4
X0321468	PLUG EXISTING DECK DRAINS	EACH	20
Z0002600	BAR SPLICERS	EACH	22
Z0006110	BRIDGE DECK MICROSILICA CONCRETE OVERLAY	SQ YD	790
Z0012200	CONCRETE BRIDGE DECK SCARIFICATION (1/2 INCH)	SQ YD	790
Z0016001	DECK SLAB REPAIR (FULL DEPTH, TYPE I)	SQ YD	1
Z0016002	DECK SLAB REPAIR (FULL DEPTH, TYPE II)	SQ YD	2
Z0016200	DECK SLAB REPAIR (PARTIAL)	SQ YD	12
*1002576	SILICONE JOINT SEAL - 2 1/2"	FOOT	47
*3000919	SILICONE JOINT SEAL - 1-1/2"	FOOT	47

NOTE:
SEE SHEET 3 OF 15 FOR GENERAL NOTES.

S.N. 057-0163

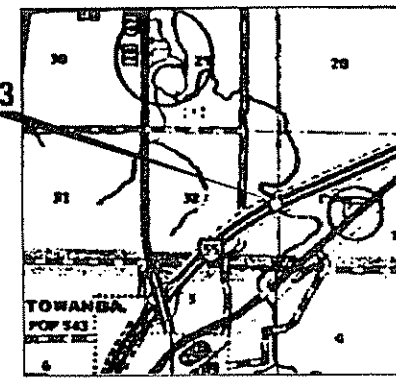

LOCATION SKETCH

GENERAL PLAN
F.A.I. 55 S.B. OVER MONEY CREEK
SECTION (57-3-1, 57-3, 57-3-2, 57-2) RS
MCLEAN COUNTY
STA. 322 + 95
S.N. 057-0163

F.A.I. RTE.	SECTION	COUNTY	TOTAL SHEETS	SHEET NO.
55	*	MCLEAN	139	64
STA.		TO STA.		
FED. ROAD DIST. NO.		ILLINOIS	FED. AID PROJECT	
* 157-3-1, 57-3, 57-3-2, 57-2) RS				

SHEET 3 of 15

General Notes:

- All structural steel shall conform to AASHTO Classification M-270 Gr. 36 unless otherwise noted.
- All Structural steel shall be shop painted with inorganic zinc rich primer per AASHTO M300, Type I. The cost shall be included in the cost of Furnishing and Erecting Structural Steel.
- The existing structural steel contains lead. The Contractor should take appropriate precautions to deal with the presence of lead on this project.
- Reinforcement bars shall conform to the requirements of AASHTO M-31, M-42 or M-53 Grade 60.
- Any reinforcement bars that are damaged during concrete removal shall be replaced with an approved bar splicer or anchorage system. Cost shall be included in the cost of "Concrete Removal".
- Existing longitudinal reinforcement extending into the removed area shall be cleaned, straightened and incorporated into the new construction. Existing transverse reinforcement may be cut as shown and removed.
- Prior to pouring the new concrete for the deck, all loose rust, loose mill scale and all other loose, detrimental foreign material shall be removed from the portions of flanges of beams in contact with concrete. The removal shall be accomplished according to the requirements of the SSPC Surface Preparation Specifications SP-3 for power tool cleaning or SP-2 for hand tool cleaning. Cost shall be included in the cost of "Concrete Superstructure".
- Joint openings shall be adjusted according to Article 503.10(c) of the Standard Specifications when the deck is poured at an ambient temperature other than 50 degrees Fahrenheit.
- Plan dimensions and details relative to existing structure have been taken from existing plans and are subject to nominal construction variations. It shall be the Contractor's responsibility to verify such dimensions and details in the field and make necessary approved adjustments prior to construction or ordering of materials. Such variations shall not be cause for additional compensation for a change in the scope of the work, however, the Contractor will be paid for the quantity actually furnished at the unit price bid for the work.

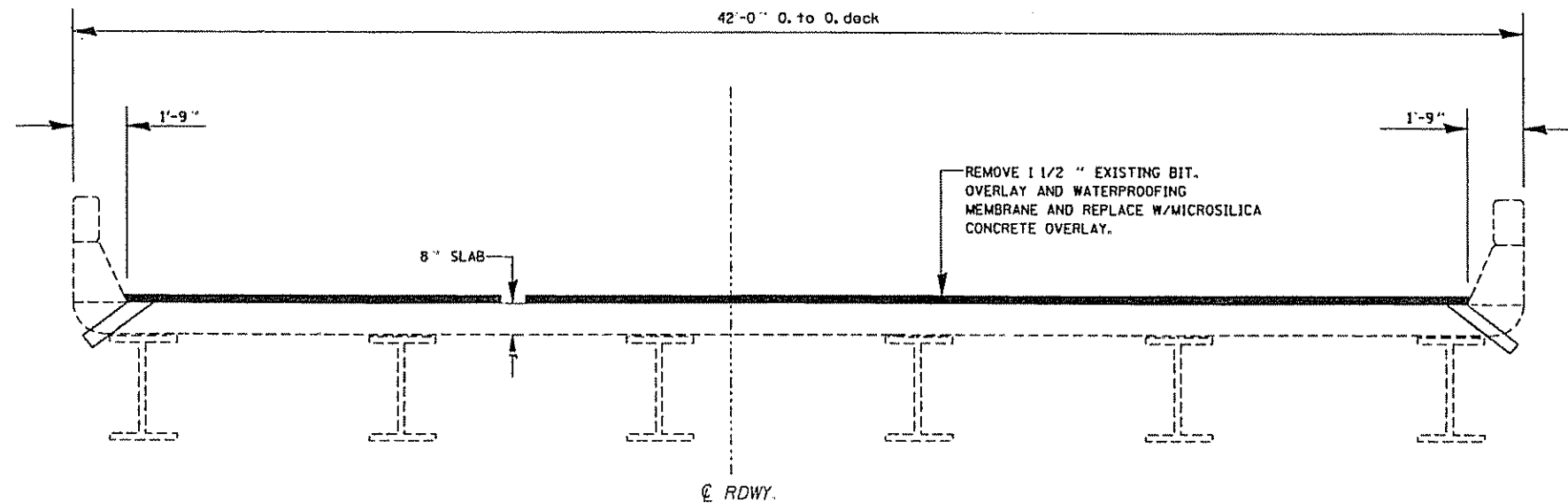

CROSS SECTION
LOOKING SOUTH

GENERAL NOTES AND TYPICAL SECTION
F.A.I. 55 S.B. OVER MONEY CREEK
SECTION (57-3-1, 57-3, 57-3-2, 57-2) RS
MCLEAN COUNTY
STA. 322+95
S.N. 057-0163

F.A.I. RTE.	SECTION	COUNTY	TOTAL SHEETS	SHEET NO.
55	•	MCLEAN	139	65
STA.		TO STA.		
FED. ROAD DIST. NO.		ILLINOIS	FED. AID PROJECT	
• (57-3-1, 57-3, 57-3-2, 57-2) RS				

SHEET 4 of 15

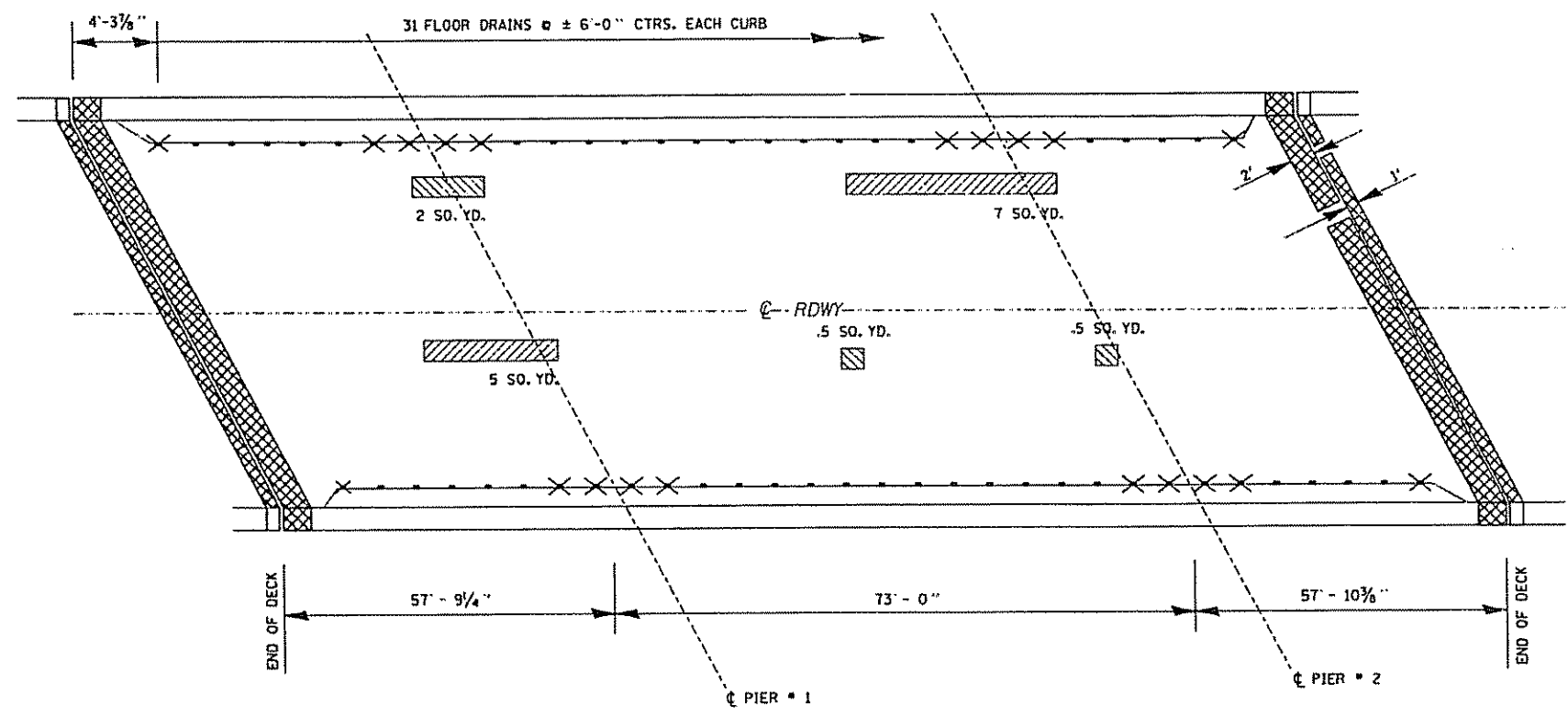

NOTES:
 AREA OF DECK REPAIRS SHOWN ARE ESTIMATED. THE ENGINEER SHALL SHOW ACTUAL LOCATIONS OF DECK REPAIRS ON AS-BUILT PLANS.
 EXISTING DECK DRAINS LOCATED WITHIN 10 FT. OF A PIER OR AN ABUTMENT SHALL BE ELIMINATED.

DECK REPAIR PLAN

	UNIT	STAGE I	STAGE II	TOTAL
CONC. REMOVAL	CU. YD.	2.7	3.3	6
CONC. SUPERSTRUCTURE	CU. YD.	2.7	3.3	6
PLUG EXISTING DECK DRAINS	EACH	10	10	20
DECK SLAB REPAIR (PARTIAL DEPTH)	SQ. YD.	5	7	12
DECK SLAB REPAIR (FULL DEPTH)	SQ. YD.	1	2	3

DECK SURVEY DATE: FEBRUARY 9, 1999

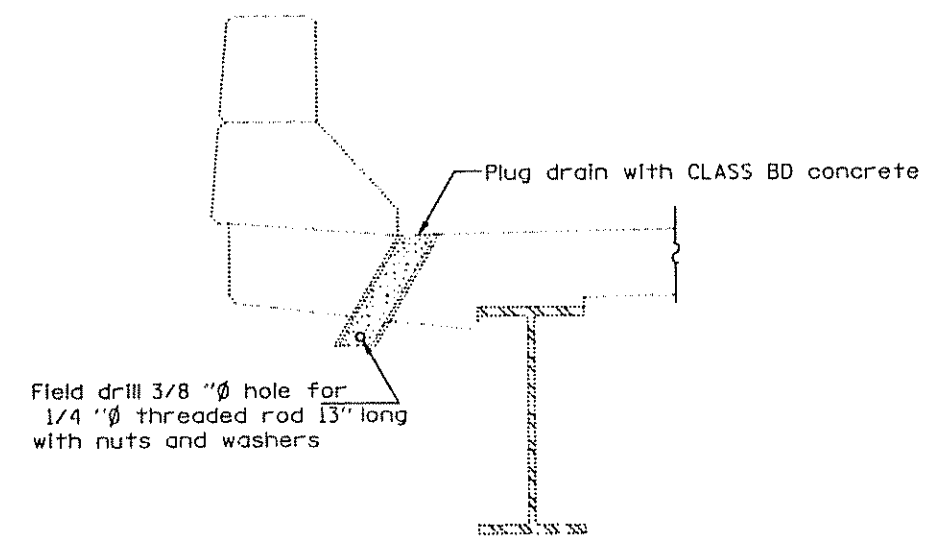

Field drill 3/8" hole for 1/4" threaded rod 13" long with nuts and washers

**SECTION AT DRAIN
 DRAIN ELIMINATION DETAILS**

DECK REPAIR PLAN
F.A.I. 55 S.B. OVER MONEY CREEK
SECTION (57-3-1, 57-3, 57-3-2, 57-2) RS
MCLEAN COUNTY
STA. 322 + 95
S.N. 057-0163

DEC. 23, 1999
 VED02100.DETAILS.DGN

BILL OF MATERIAL SN 057-0163				
BAR	NO.	SIZE	LENGTH (FT.)	SHAPE
a(E)	22	#6	20'-3"	—
a1(E)	12	#6	4'-0"	—
a2(E)	22	#6	24'-11"	—
d(E)	12	#4	4'-9"	┌
d1(E)	12	#5	3'-5"	┌
d3(E)	8	#4	2'-1"	┌
d4(E)	80	#5	2'-5"	┌
CONCRETE REMOVAL			CU YD	6
CONC. SUPERSTRUCTURE			CU YD	6
BAR SPLICERS			EACH	22
FURN. & ERECT STRUCT. STEEL			POUND	3385
REINFORCEMENT BARS, EPOXY COATED			POUND	1859

REINFORCEMENT BARS DESIGNATED (E) SHALL BE EPOXY COATED

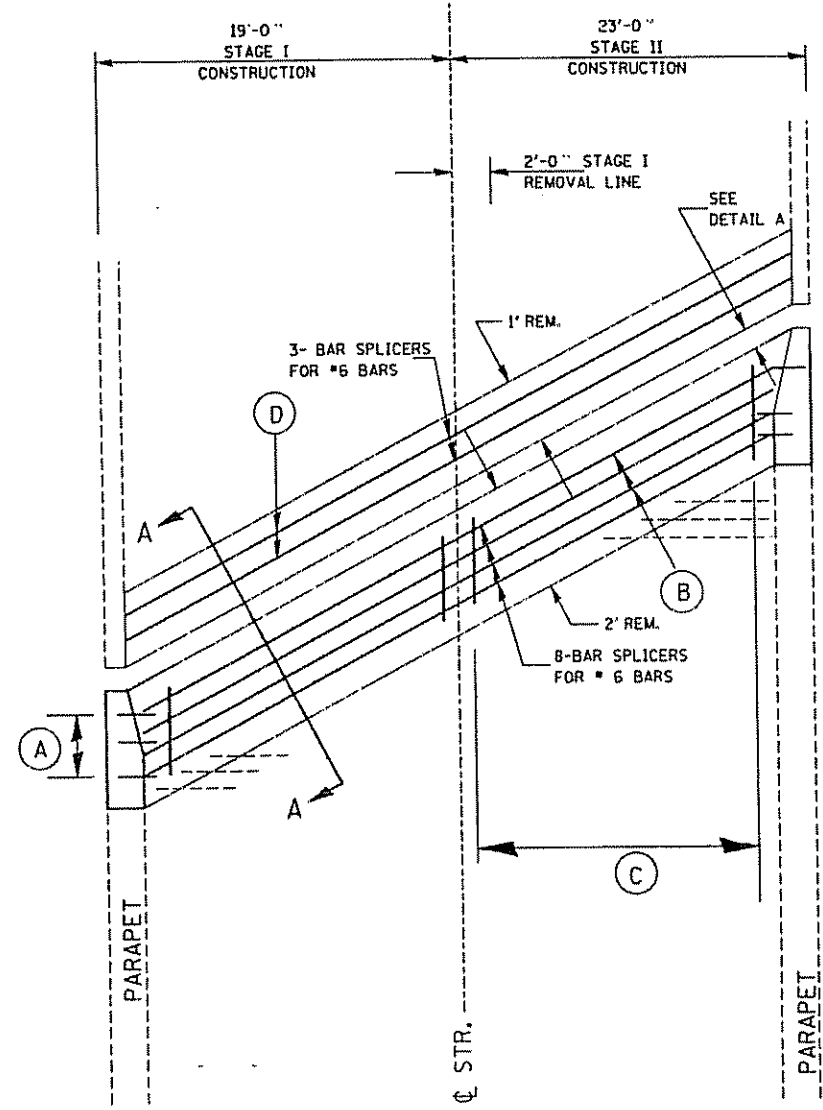

- BARS REQUIRED FOR EACH STAGE**
- (A) 3- #4 d(E) Bars
3- #5 d₁(E) Bars
2- #4 d₃(E) Bars @ ea. rail post
3- #6 a₁(E) Bars (Top)
(Lap with a(E) & a₂(E))
 - (B) 4- #6 a(E) Bars (Top - Stage I), (a₂(E) Bars Top - Stage II)
4- #6 a(E) Bars (Bottom - Stage I), (a₂(E) Bars Bottom - Stage II)
 - (C) 18- #5 d₄(E) Bars @ 12" ctrs. (Stage I)
22- #5 d₄(E) Bars @ 12" ctrs. (Stage II)
 - (D) 1- #6 a(E) Bar (Top - Stage I), (a₂(E) Bars Top - Stage II)
2- #6 a(E) Bars (Bottom - Stage I), (a₂(E) Bars Bottom - Stage II)
- Min Bar Lap
#6 Bar 2'-7"

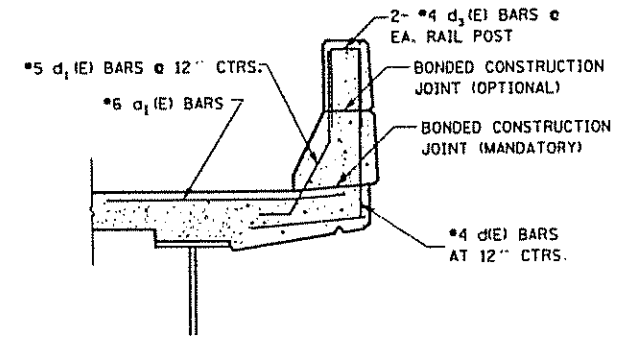
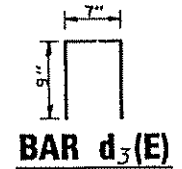

SECTION THRU PARAPET (DECK SIDE)

PLAN AT SOUTH ABUTMENT (NORTH ABUTMENT MIRROR IMAGE)

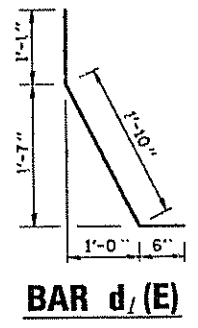
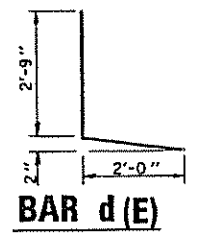
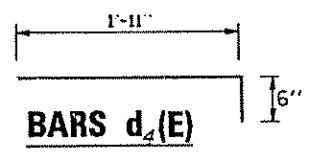
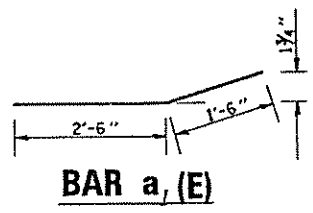

EXPANSION JOINT REPLACEMENT DETAILS
F.A.I. 55 S.B. OVER MONEY CREEK
SECTION (57-3-1, 57-3, 57-3-2, 57-2) RS
MCLEAN COUNTY
STA. 322+95
S.N. 057-0163

F.A.I. RTE.	SECTION	COUNTY	TOTAL SHEETS	SHEET NO.
55	♦	MCLEAN	139	67
STA. 322+95		TO STA. 322+95		
FED. ROAD DIST. NO. ILLINOIS FED. AID PROJECT				
# 57-3-1, 57-3, 57-3-2, 57-2) RS				

SHEET 6 of 15

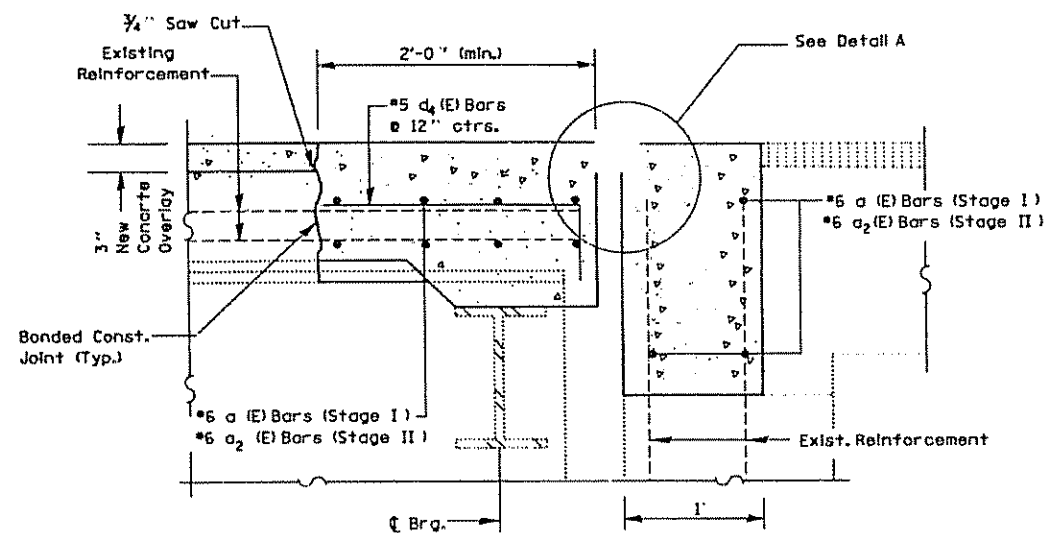

SECTION A - A

NOTES:

1. THE LIMITS OF ALL CONCRETE REMOVAL SHALL BE SAW CUT 3/4" INTO CONCRETE.
2. EXISTING TRANSVERSE BARS EXTENDING FROM DECK INTO REMOVED AREA SHALL BE CUT ALLOWING 2'-0" TO EXTEND INTO THE REMOVED AREA. IN ADDITION, THESE CUT BARS SHALL BE CLEANED, STRAIGHTENED, AND INCORPORATED INTO THE NEW CONSTRUCTION
3. EXISTING LONGITUDINAL BARS IN DECK AND VERTICAL BARS IN ABUTMENT BACKWALL EXTENDING INTO THE REMOVED AREA SHALL BE CLEANED, STRAIGHTENED, AND INCORPORATED IN THE NEW WORK.
4. EXISTING PARAPET REINFORCEMENT EXTENDING INTO THE REMOVED AREA SHALL BE CLEANED, STRAIGHTENED AND INCORPORATED INTO THE NEW CONSTRUCTION.
5. THE REMOVAL AND REPLACEMENT OF CONCRETE AT THE ABUTMENT BACKWALL, PARAPET, AND DECK WILL BE PAID FOR AS CONCRETE REMOVAL AND CONCRETE SUPERSTRUCTURE.
6. THE PARAPET SHALL BE REMOVED ON THE DECK SIDE, BUT SHALL REMAIN IN PLACE ON THE ABUTMENT SIDE. CONCRETE REMOVAL AT THE ABUTMENT SHALL BE FROM FACE OF PARAPET TO FACE OF PARAPET.
7. THE REMOVAL OF EXISTING PJS AND STEEL ARMOUR SHALL BE INCLUDED IN THE COST OF "CONCRETE REMOVAL".

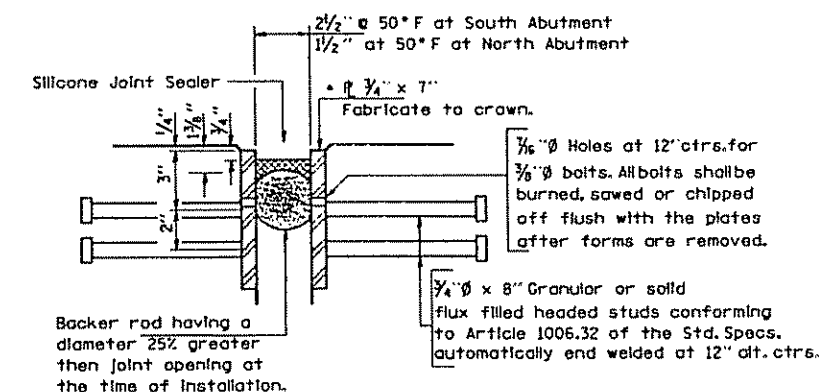

NOTE: After fabrication all surfaces of the steel plates shall be given one shop coat of paint specified for Structural Steel. No field painting required.

- Furnish in segments of 20 ft. maximum length. Maximum space between installed segments shall be 3/16". Seal space with Silicone Sealant suitable for Structural Steel.

SILICONE JOINT SEALER
DETAIL A

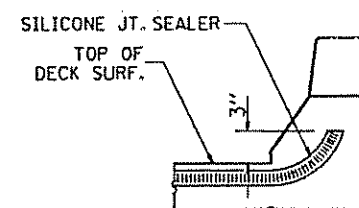

TYPICAL END OF SEAL TREATMENT

EXPANSION JOINT REPLACEMENT DETAILS
F.A.I. 55 S.B. OVER MONEY CREEK
SECTION (57-3-1, 57-3, 57-3-2, 57-2) RS
MCLEAN COUNTY
STA. 322+95
S.N. 057-0163

F.A.I. RTE.	SECTION	COUNTY	TOTAL SHEETS	SHEET NO.
55	*	MCLEAN	139	68
STA.		TO STA.		
FED. ROAD DIST. NO.		ILLINOIS FED. AID PROJECT		
157-3-1, 57-3, 57-3-2, 57-21 RS				

SHEET 7 of 15

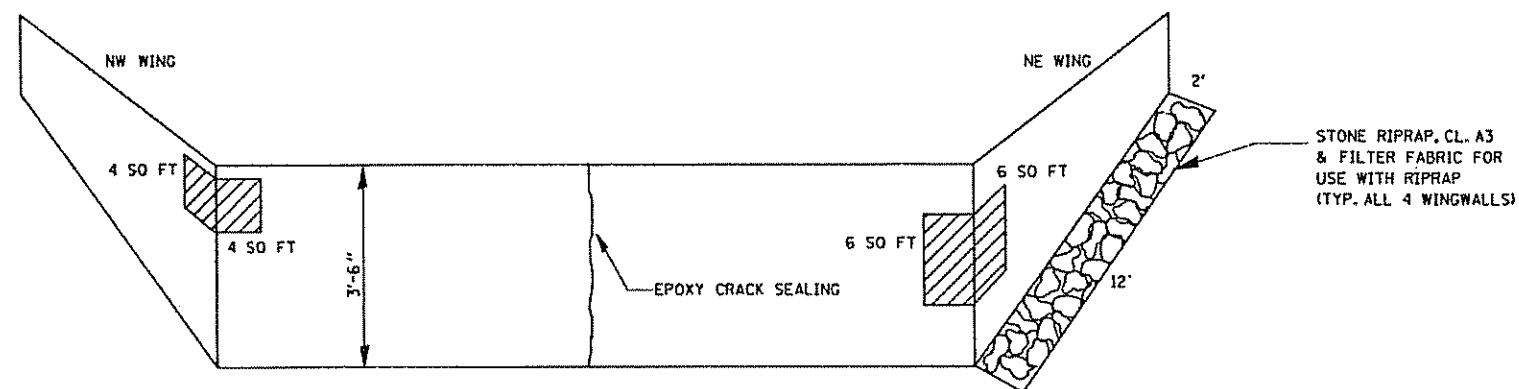

NORTH ABUTMENT BACKWALL

EPOXY CRACK SEALING = 3' - 6"

FORMED CONCRETE REPAIR \leq 5" = 20 S.F.

STONE RIPRAP, CL. A3 & FILTER FABRIC FOR USE WITH RIPRAP (TYP. ALL 4 WINGWALLS)

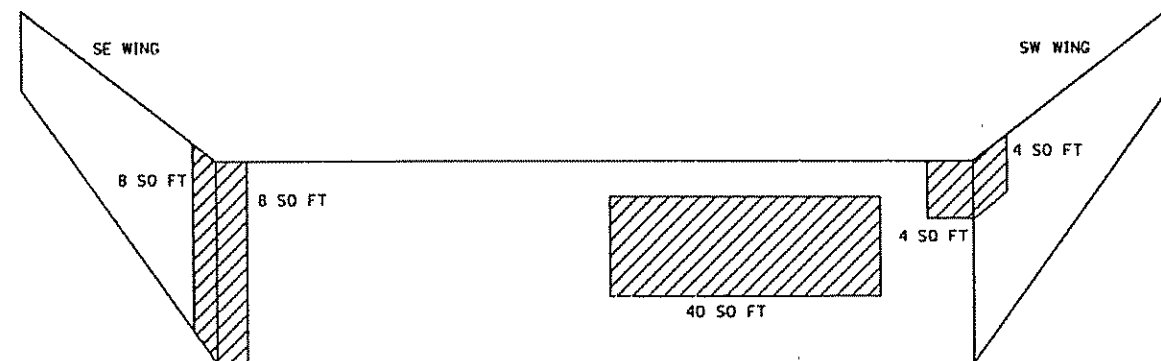

SOUTH ABUTMENT BACKWALL

FORMED CONCRETE REPAIR \leq 5" = 64 S.F.

EPOXY CRACK SEALING = 4'
 FORMED CONCRETE REPAIR \leq 5" = 84 S.F.
 RIPRAP = 96 SQ FT

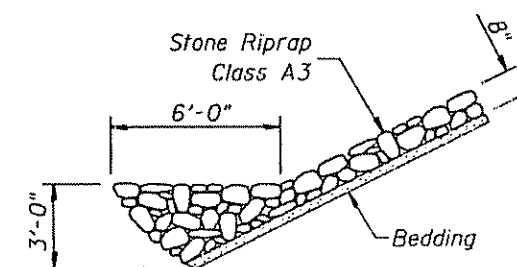

STONE RIPRAP ANCHOR DETAIL

ABUTMENT CRACKS AND SPALLS
 S.N. 057-0163

ABUTMENT REPAIRS
 F.A.I. 55 S.B. OVER MONEY CREEK
 SECTION (57-3-1, 57-3, 57-3-2, 57-2) RS
 MCLEAN COUNTY
 STA. 322 + 95
 S.N. 057-0163

F.A.I. RTE.	SECTION	COUNTY	TOTAL SHEETS	SHEET NO.
55	*	MCLEAN	139	69
STA.	TO STA.			
FED. ROAD DIST. NO.	ILLINOIS	FED. AID PROJECT		
• (57-3-1, 57-3, 57-3-2, 57-2) RS				
SHEET 8 of 15				

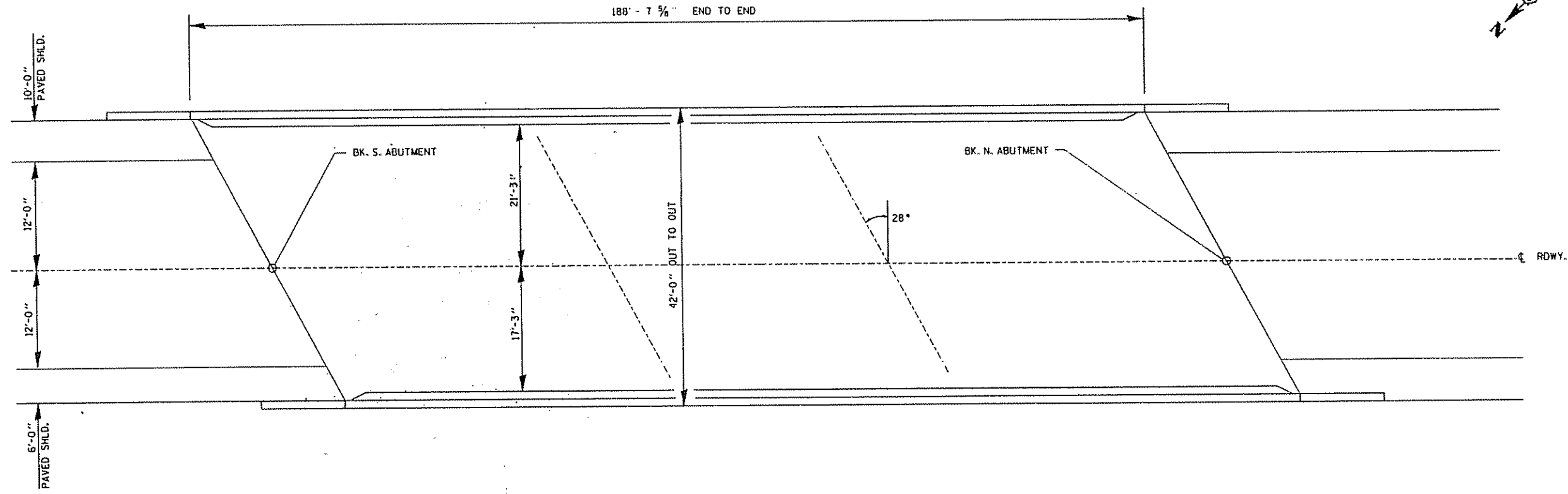

TOTAL BILL OF MATERIALS S.N. 057-0164			
CODE NO.	ITEM	UNIT	QUANT
20300100	CHANNEL EXCAVATION	CU YD	500
28100105	STONE RIPRAP, CLASS A3	SO YD	11
28100107	STONE RIPRAP, CLASS A4	SO YD	143
28200100	FILTER FABRIC FOR USE WITH RIPRAP	SO YD	167
44001000	BITUMINOUS CONCRETE REMOVAL (DECK)	SO YD	807
50102400	CONCRETE REMOVAL	CU YD	6
50300255	CONCRETE SUPERSTRUCTURE	CU YD	6
50300260	BRIDGE DECK GROOVING	SO YD	765
50300300	PROTECTIVE COAT	SO YD	823
50301245	FORMED CONCRETE REPAIR (DEPTH LESS THAN OR EQUAL TO 5")	SO FT	30
50500405	FURNISHING AND ERECTING STRUCTURAL STEEL	POUND	3385
50800205	REINFORCEMENT BARS, EPOXY COATED	POUND	1859
59000100	EPOXY CRACK SEALING	FOOT	15
X0321468	PLUG EXISTING DECK DRAINS	EACH	20
Z0002600	BAR SPLICERS	EACH	22
Z0006110	BRIDGE DECK MICROSILICA CONCRETE OVERLAY	SO YD	790
Z0012200	CONCRETE BRIDGE DECK SCARIFICATION (1/2 INCH)	SO YD	790
Z0016001	DECK SLAB REPAIR (FULL DEPTH, TYPE I)	SO YD	1
Z0016002	DECK SLAB REPAIR (FULL DEPTH, TYPE II)	SO YD	1
Z0016200	DECK SLAB REPAIR (PARTIAL)	SO YD	7
#1002576	SILICONE JOINT SEAL - 2 1/2"	FOOT	47
#3000919	SILICONE JOINT SEAL - 1-1/2"	FOOT	47

NOTE:
SEE SHEET 9 OF 15 FOR GENERAL NOTES.

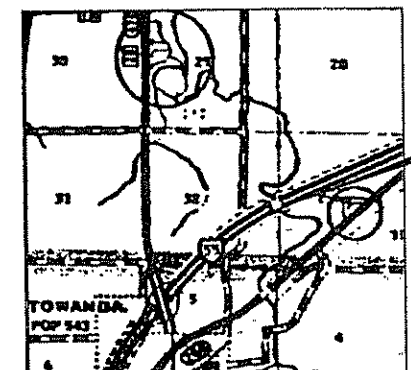

LOCATION SKETCH

GENERAL PLAN
F.A.I. 55 N.B. OVER MONEY CREEK
SECTION (57-3-1, 57-3, 57-3-2, 57-2) RS
MCLEAN COUNTY
STA. 322 + 95
S.N. 057-0164

F.A.I. RTE.	SECTION	COUNTY	TOTAL SHEETS	SHEET NO.
55	•	MCLEAN	139	70
STA.		TO STA.		
FED. ROAD DIST. NO.	ILLINOIS	FED. AID PROJECT		
• 57-3-1, 57-3, 57-3-2, 57-2) RS				

SHEET 9 of 15

General Notes:

1. All structural steel shall conform to AASHTO Classification M-270 Gr. 36 unless otherwise noted.
2. All Structural steel shall be shop painted with inorganic zinc rich primer per AASHTO M300, Type 1. The cost shall be included in the cost of Furnishing and Erecting Structural Steel.
3. The existing structural steel contains lead. The Contractor should take appropriate precautions to deal with the presence of lead on this project.
4. Reinforcement bars shall conform to the requirements of AASHTO M-31, M-42 or M-53 Grade 60.
5. Any reinforcement bars that are damaged during concrete removal shall be replaced with an approved bar splicer or anchorage system. Cost shall be included in the cost of "Concrete Removal".
6. Existing longitudinal reinforcement extending into the removed area shall be cleaned, straightened and incorporated into the new construction. Existing transverse reinforcement may be cut as shown and removed.
7. Prior to pouring the new concrete for the deck, all loose rust, loose mill scale and all other loose, detrimental foreign material shall be removed from the portions of flanges of beams in contact with concrete. The removal shall be accomplished according to the requirements of the SSPC Surface Preparation Specifications SP-3 for power tool cleaning or SP-2 for hand tool cleaning. Cost shall be included in the cost of "Concrete Superstructure".
8. Joint openings shall be adjusted according to Article 503.10(c) of the Standard Specifications when the deck is poured at an ambient temperature other than 50 degrees Fahrenheit.
9. Plan dimensions and details relative to existing structure have been taken from existing plans and are subject to nominal construction variations. It shall be the Contractor's responsibility to verify such dimensions and details in the field and make necessary approved adjustments prior to construction or ordering of materials. Such variations shall not be cause for additional compensation for a change in the scope of the work, however, the Contractor will be paid for the quantity actually furnished at the unit price bid for the work.

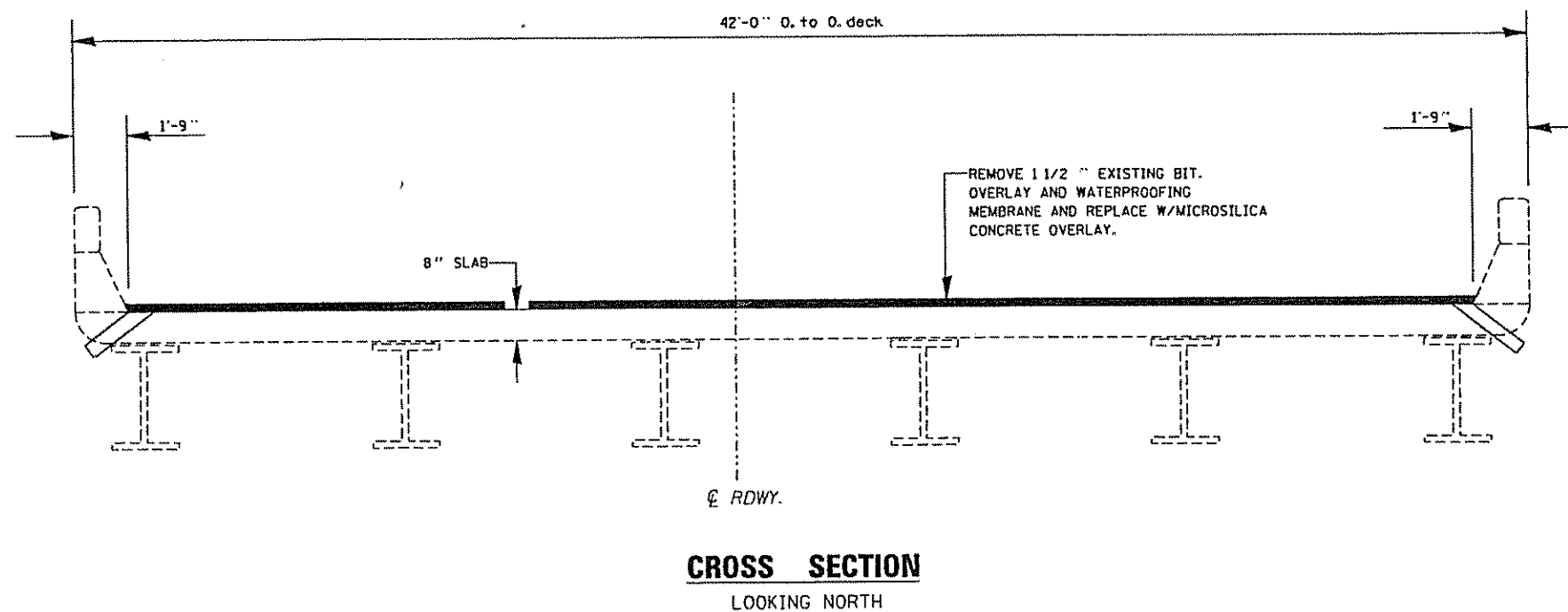

CROSS SECTION
LOOKING NORTH

GENERAL NOTES AND TYPICAL SECTION
F.A.I. 55 N.B. OVER MONEY CREEK
SECTION (57-3-1, 57-3, 57-3-2, 57-2) RS
MCLEAN COUNTY
STA. 322+95
S.N. 057-0164

F.A.I. RTE.	SECTION	COUNTY	TOTAL SHEETS	SHEET NO.
55	*	MCLEAN	139	71
STA.	TO STA.			
FED. ROAD DIST. NO.	ILLINOIS	FED. AID PROJECT		
• (57-3-1, 57-3, 57-3-2, 57-2) RS				
SHEET 10 of 15				

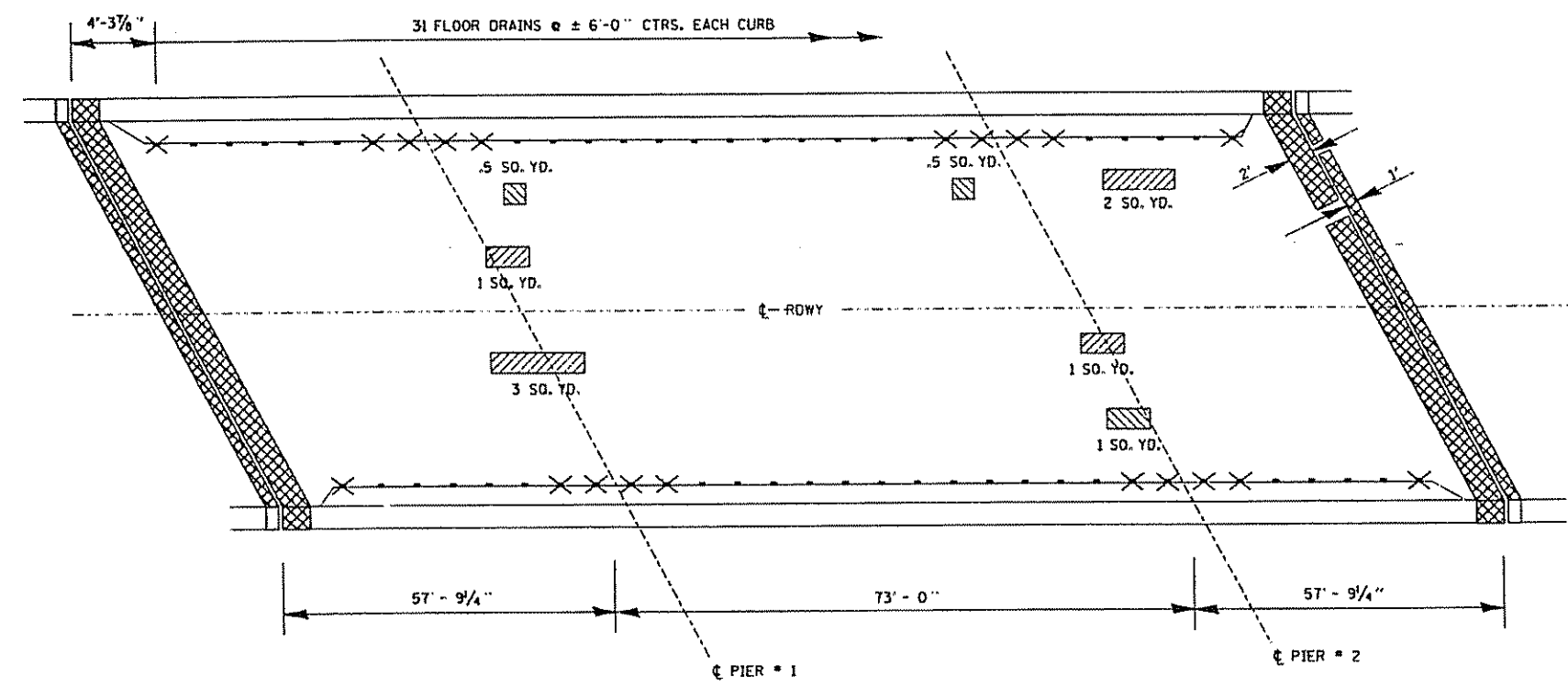
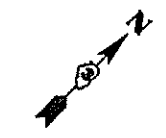

NOTES:

AREA OF DECK REPAIRS SHOWN ARE ESTIMATED. THE ENGINEER SHALL SHOW ACTUAL LOCATIONS OF DECK REPAIRS ON AS-BUILT PLANS.

EXISTING DECK DRAINS LOCATED WITHIN 10 FT. OF A PIER OR AN ABUTMENT SHALL BE ELIMINATED.

DECK REPAIR PLAN

	UNIT	STAGE I	STAGE II	TOTAL
CONC. REMOVAL	CU. YD.	2.7	3.3	6
CONC. SUPERSTRUCTURE	CU. YD.	2.7	3.3	6
PLUG EXISTING DECK DRAINS	EACH	10	10	20
DECK SLAB REPAIR (PARTIAL DEPTH)	SO. YD.	3	4	7
DECK SLAB REPAIR (FULL DEPTH)	SO. YD.	1	1	2

DECK SURVEY DATE: FEBRUARY 9, 1999

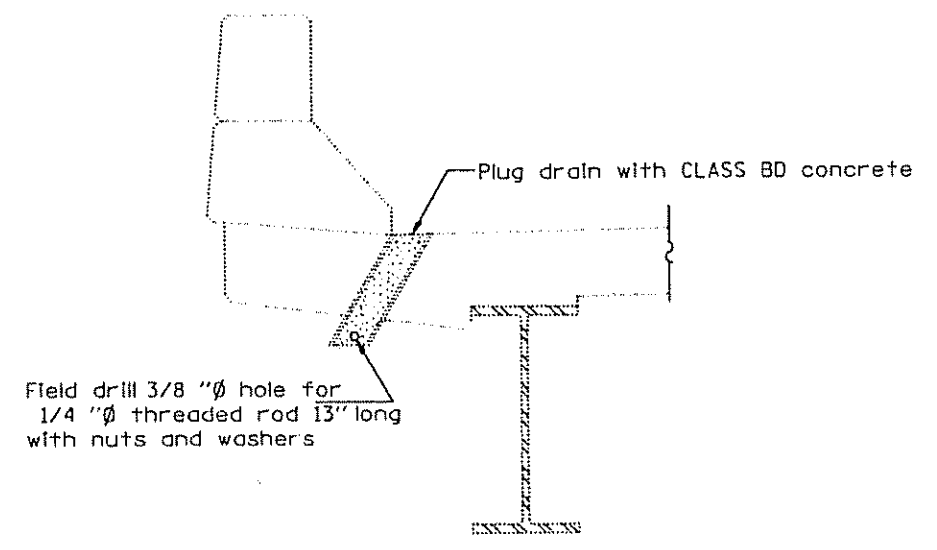

SECTION AT DRAIN
DRAIN ELIMINATION DETAILS

DECK REPAIR PLAN
F.A.I. 55 N.B. OVER MONEY CREEK
SECTION (57-3-1, 57-3, 57-3-2, 57-2) RS
MCLEAN COUNTY
STA. 322 + 95
S.N. 057-0164

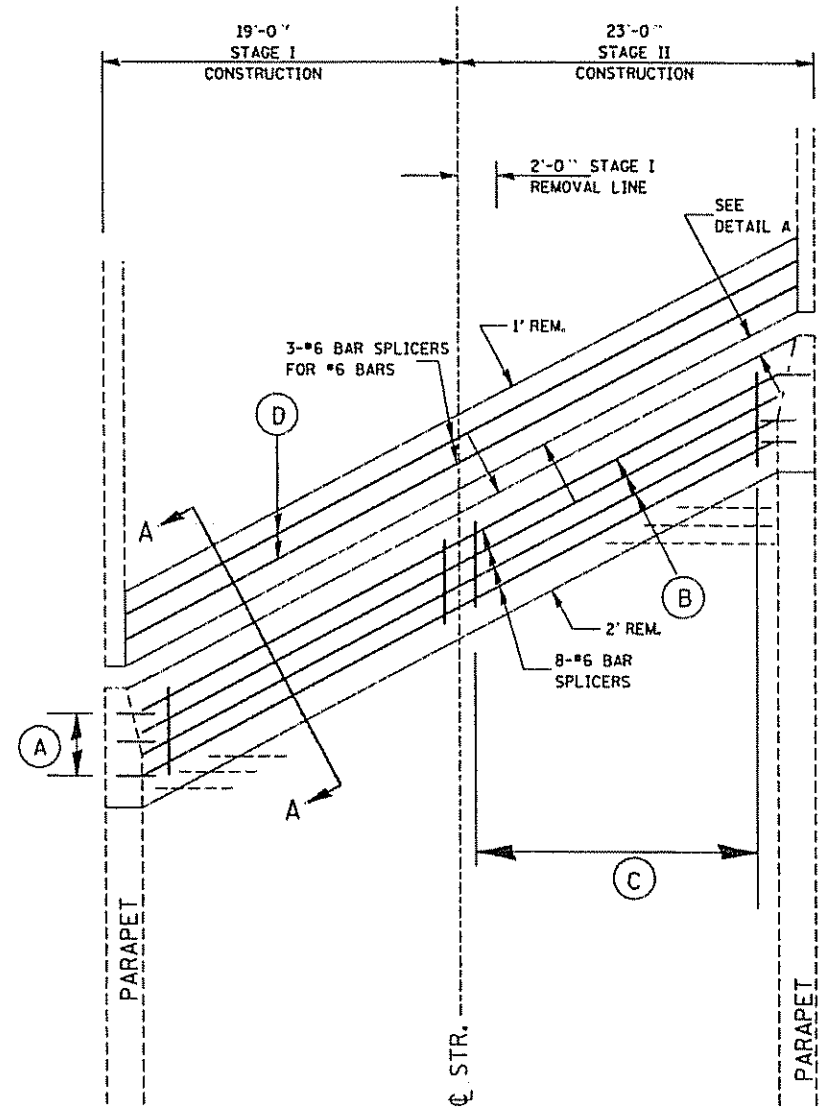

BARS REQUIRED FOR EACH STAGE

- (A) 3- #4 d (E) Bars
3- #5 d₁ (E) Bars
2- #4 d₃ (E) Bars @ ea. rail post
3- #6 a₁ (E) Bars (Top)
(Lap with a₁ (E) & a₂ (E))
- (B) 4- #6 a (E) Bars (Top - Stage I), (a₂ (E) Bars Top - Stage II)
4- #6 a (E) Bars (Bottom - Stage I), (a₂ (E) Bars Bottom - Stage II)
- (C) 18- #5 d₄ (E) Bars @ 12" ctrs. (Stage I)
22- #5 d₄ (E) Bars @ 12" ctrs. (Stage II)
- (D) 1- #6 a (E) Bar (Top - Stage I), (a₂ (E) Bars Top - Stage II)
2- #6 a (E) Bars (Bottom - Stage I), (a₂ (E) Bars Bottom - Stage II)

Min Bar Lap
#6 Bar 2'-7"

**PLAN AT NORTH ABUTMENT
(SOUTH ABUTMENT MIRROR IMAGE)**

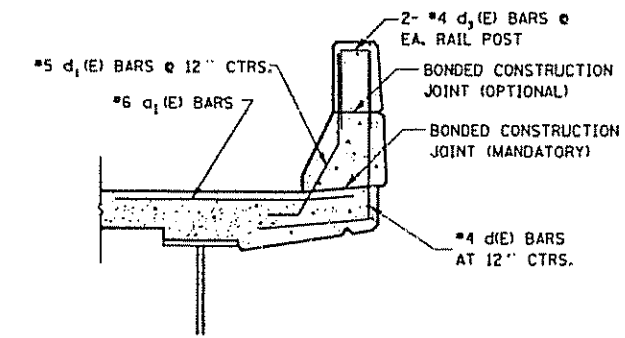
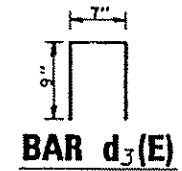
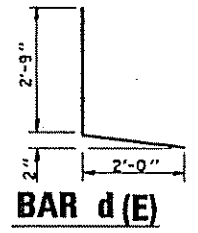

**SECTION THRU PARAPET
(DECK SIDE)**

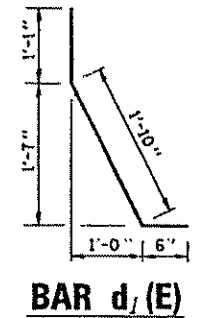
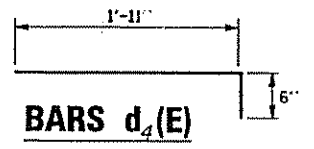
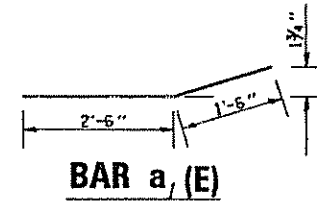

BILL OF MATERIAL SN 057-0164				
BAR	NO.	SIZE	LENGTH (FT.)	SHAPE
d (E)	22	#6	20'-3"	—
a1 (E)	12	#6	4'-0"	—
a2 (E)	22	#6	24'-11"	—
d (E)	12	#4	4'-9"	L
d1 (E)	12	#5	3'-5"	L
d3 (E)	8	#4	2'-1"	Π
d4 (E)	80	#5	2'-5"	—
CONCRETE REMOVAL			CU YD	6
CONC. SUPERSTRUCTURE			CU YD	6
BAR SPLICERS			EACH	22
FURN. & ERECT STRUCT. STEEL			POUND	3385
REINFORCEMENT BARS, EPOXY COATED			POUND	1859

REINFORCEMENT BARS DESIGNATED (E) SHALL BE EPOXY COATED

EXPANSION JOINT REPLACEMENT DETAILS
F.A.I. 55 N.B. OVER MONEY CREEK
SECTION (57-3-1, 57-3, 57-3-2, 57-2) RS
MCLEAN COUNTY
STA. 322 + 95
S.N. 057-0164

F.A.I. RTE.	SECTION	COUNTY	TOTAL SHEETS	SHEET NO.
55	*	MCLEAN	139	73
STA.	TO STA.			
FED. ROAD DIST. NO.	ILLINOIS	FED. AID PROJECT		
* 57-3-1, 57-3, 57-3-2, 57-2) RS				

SHEET 12 of 15

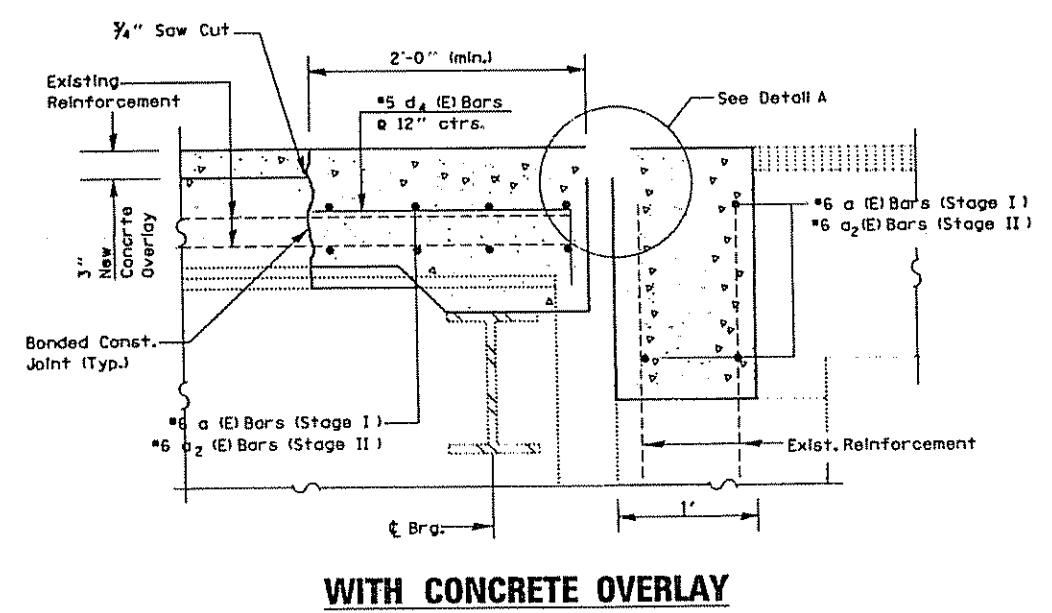

WITH CONCRETE OVERLAY

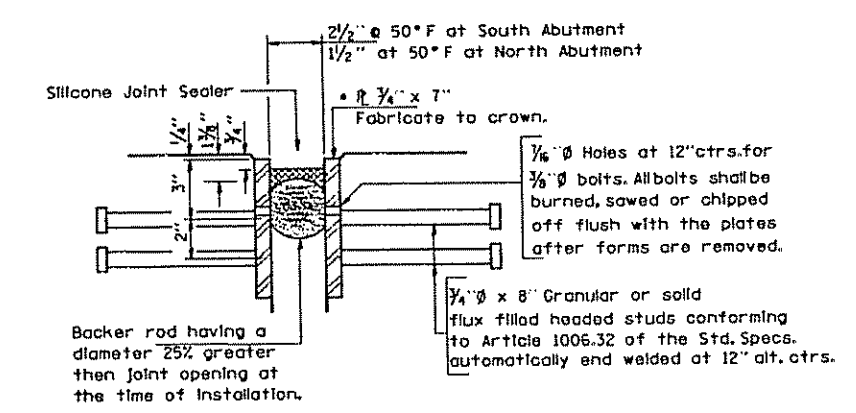

NOTE: After fabrication all surfaces of the steel plates shall be given one shop coat of paint specified for Structural Steel. No field painting required.

* Furnish in segments of 20 ft. maximum length. Maximum space between installed segments shall be 1/8\".

**SILICONE JOINT SEALER
DETAIL A**

NOTES:

1. THE LIMITS OF ALL CONCRETE REMOVAL SHALL BE SAW CUT 3/4" INTO CONCRETE.
2. EXISTING TRANSVERSE BARS EXTENDING FROM DECK INTO REMOVED AREA SHALL BE CUT ALLOWING 2'-0" TO EXTEND INTO THE REMOVED AREA. IN ADDITION, THESE CUT BARS SHALL BE CLEANED, STRAIGHTENED, AND INCORPORATED INTO THE NEW CONSTRUCTION
3. EXISTING LONGITUDINAL BARS IN DECK AND VERTICAL BARS IN ABUTMENT BACKWALL EXTENDING INTO THE REMOVED AREA SHALL BE CLEANED, STRAIGHTENED, AND INCORPORATED IN THE NEW WORK.
4. EXISTING PARAPET REINFORCEMENT EXTENDING INTO THE REMOVED AREA SHALL BE CLEANED, STRAIGHTENED AND INCORPORATED INTO THE NEW CONSTRUCTION.
5. THE REMOVAL AND REPLACEMENT OF CONCRETE AT THE ABUTMENT BACKWALL, PARAPET, AND DECK WILL BE PAID FOR AS CONCRETE REMOVAL AND CONCRETE SUPERSTRUCTURE.
6. THE PARAPET SHALL BE REMOVED ON THE DECK SIDE, BUT SHALL REMAIN IN PLACE ON THE ABUTMENT SIDE. CONCRETE REMOVAL AT THE ABUTMENT SHALL BE FROM FACE OF PARAPET TO FACE OF PARAPET.
7. THE REMOVAL OF EXISTING PJS AND STEEL ARMOUR SHALL BE INCLUDED IN THE COST OF "CONCRETE REMOVAL".

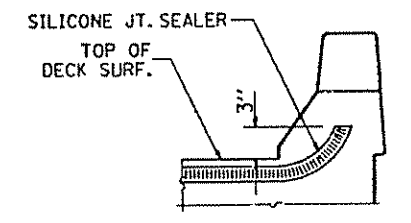

TYPICAL END OF SEAL TREATMENT

**EXPANSION JOINT REPLACEMENT DETAILS
F.A.I. 55 N.B. OVER MONEY CREEK
SECTION (57-3-1, 57-3, 57-3-2, 57-2) RS
MCLEAN COUNTY
STA. 322 + 95
S.N. 057-0164**

DEC. 23, 1999
VED02100V.DETAILS.DGN

F.A.I. SHEETS	SECTION	COUNTY	TOTAL SHEETS	SHEET NO.
55	*	MCLEAN	139	74
STA.		TO STA.		
FED. ROAD DIST. NO.		ILLINOIS FED. AID PROJECT		
● (57-3-1, 57-3, 57-3-2, 57-2) RS				
SHEET 13 of 15				

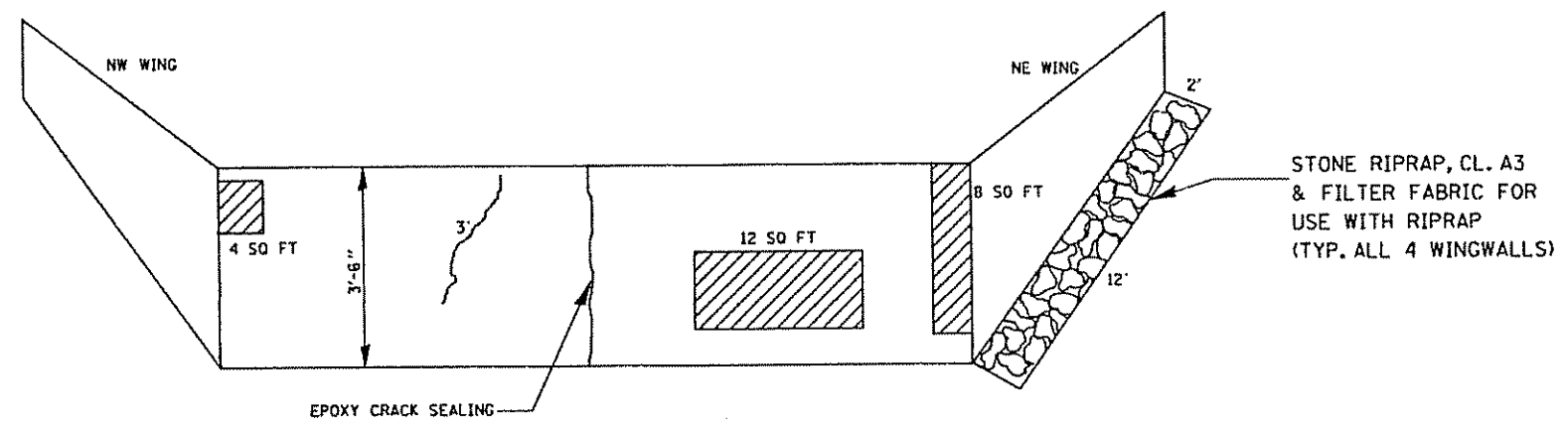

NORTH ABUTMENT BACKWALL

EPOXY CRACK SEALING = 6'-6"

FORMED CONCRETE REPAIR ≤ 5" = 24 S.F.

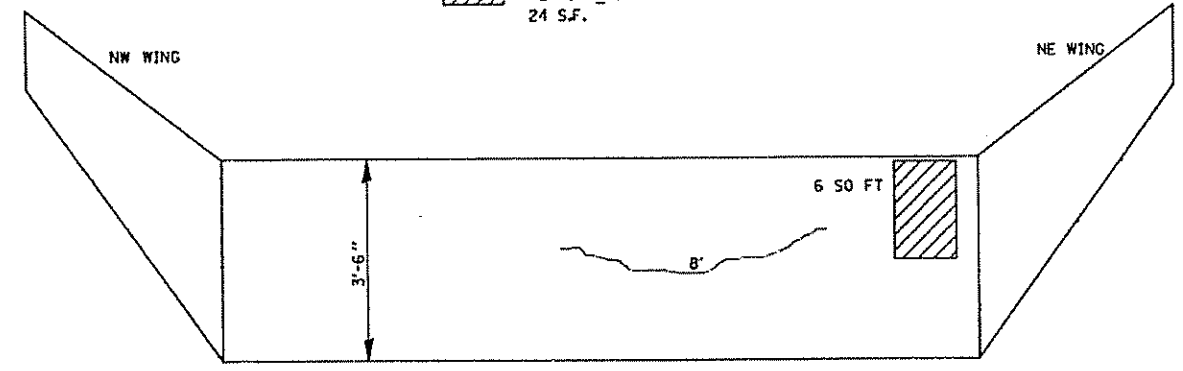

SOUTH ABUTMENT BACKWALL

EPOXY CRACK SEALING = 8'

FORMED CONCRETE REPAIR ≤ 5" = 6 S.F.

EPOXY CRACK SEALING = 15'

FORMED CONCRETE REPAIR ≤ 5" = 30 S.F.

RIPRAP = 96 SQ FT

ABUTMENT CRACKS AND SPALLS
S.N. 057-0164

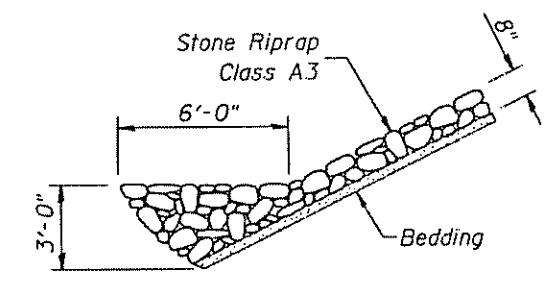

STONE RIPRAP ANCHOR DETAIL

ABUTMENT REPAIRS
F.A.I. 55 N.B. OVER MONEY CREEK
SECTION (57-3-1, 57-3, 57-3-2, 57-2) RS
MCLEAN COUNTY
STA. 322 + 95
S.N. 057-0164

DEC. 23, 1999
VEDD/100/DETAILS.DGN

F.A.I. RTE.	SECTION	COUNTY	TOTAL SHEETS	SHEET NO.
55	*	MCLEAN	139	75
STA.		TO STA.		
FED. ROAD DIST. NO.		ILLINOIS	FED. AID PROJECT	
* (57-3-1, 57-3, 57-3-2, 57-2) RS				

SHEET 14 of 15

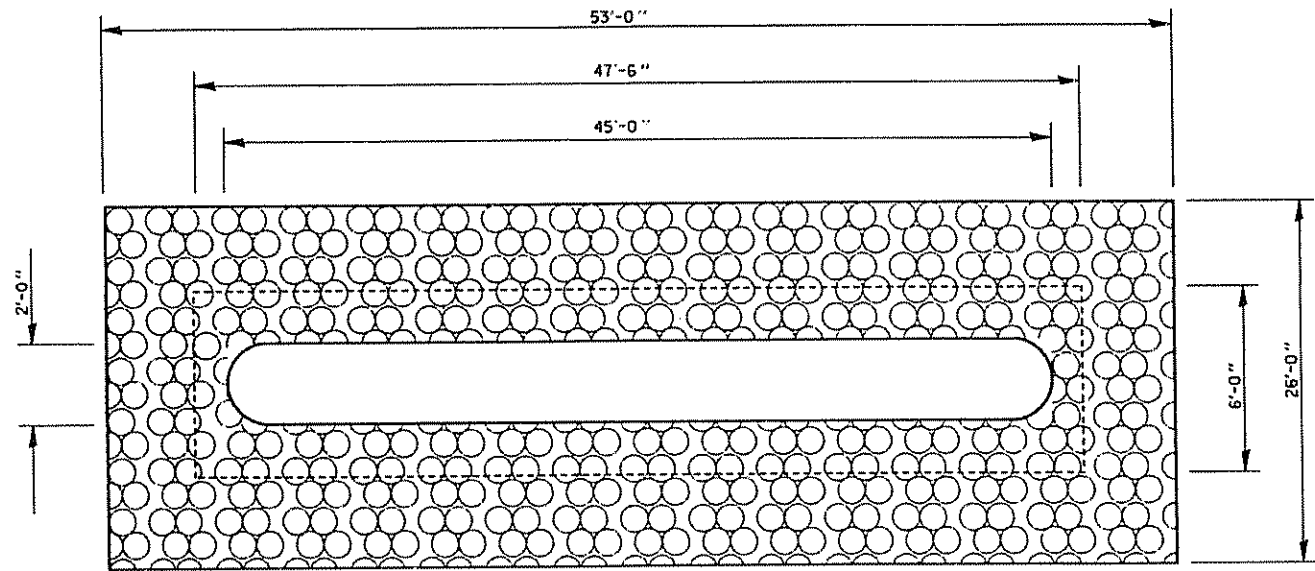

PIER #2

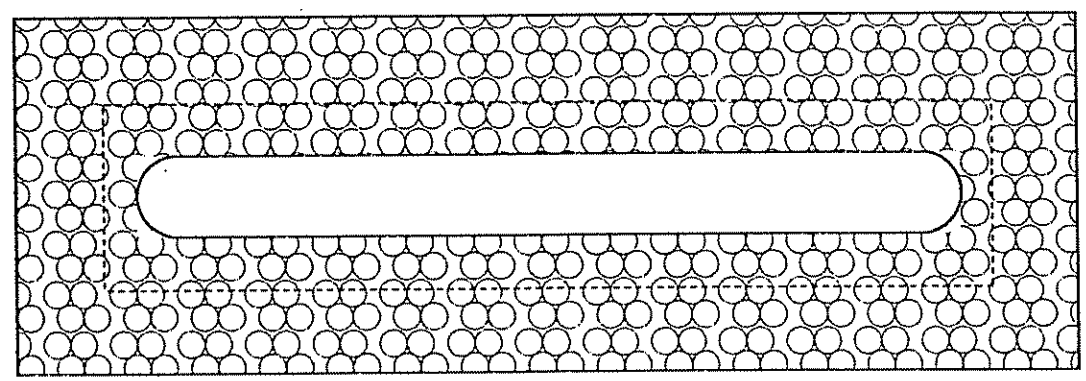

PIER #1

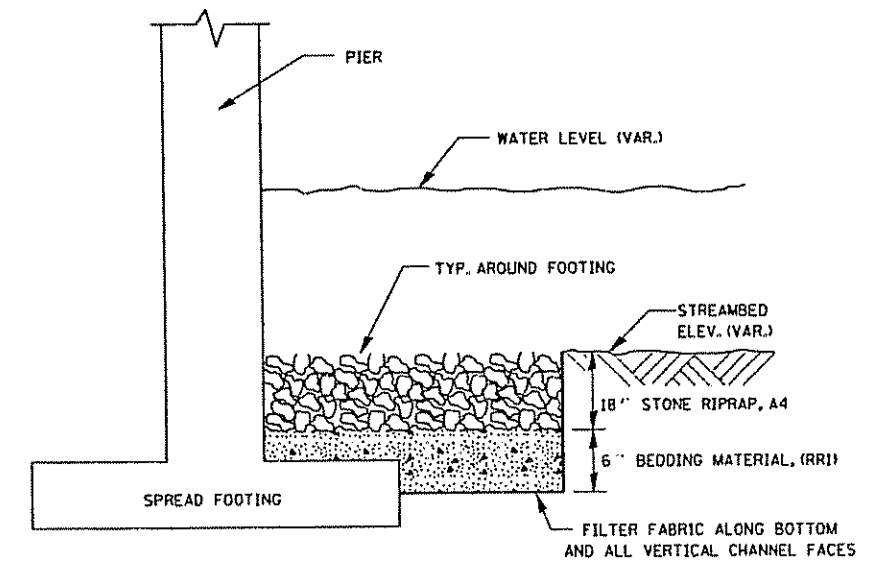

**TYPICAL SECTION FOR PIER.
RIPRAP CLASS A4**

NOTE: CHANNEL EXCAVATION SHALL NOT EXCEED BOTTOM OF FOOTING

**STR. # 057-0163 & STR. # 057-0164
PIERS 1 & 2**

**RIPRAP AT PIERS
F.A.I. 55 S.B. OVER MONEY CREEK
SECTION (57-3-1, 57-3, 57-3-2, 57-2) RS
MCLEAN COUNTY
STA. 322 + 95
S.N. 057-0163 & S.N. 057-0164**

DEC. 23, 1999
VED021CON.DETAILS.DGN

STATE OF ILLINOIS
DEPARTMENT OF TRANSPORTATION

PROJECT NO.	DISTRICT	CONTRACT	SHEETS	SHEET NO.
		MCLEAN	139	76
SHEET NO. 15				
15 SHEETS				
* 157-3-1,57-3,57-3-2,57-2RS				

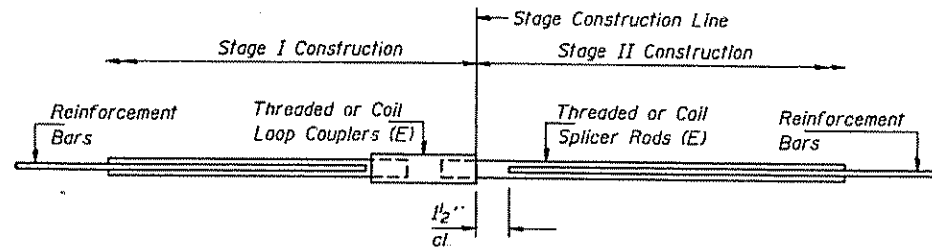

SPLICER DETAIL

Bar Size	No. Assemblies Required	Location
#6	22	Stage Construction Line S.N. 057-0163
#6	22	Stage Construction Line S.N. 057-0164
Total	44	

The diameter of this part is the same as the diameter of the bar spliced.

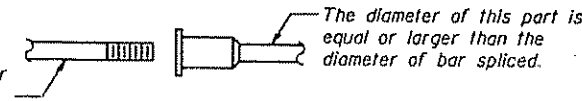

ROLLED THREAD DOWEL BAR



ONE PIECE

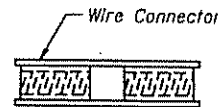

WELDED SECTIONS

BAR SPLICER ASSEMBLY ALTERNATIVES

** Heavy Hex Nuts conforming to ASTM A 563, Grade C, D or DH may be used

NOTES

Bar splicer assemblies shall be of an approved type and shall develop in tension at least 125 percent of the yield strength of the lapped reinforcement bars.
Splicer rods shall be of minimum 60 ksi yield strength, threaded or coiled full length.
All reinforcement bars shall be lapped and tied to the splicer rods or dowel bars.
Bar splicer assemblies shall be epoxy coated according to the requirements for reinforcement bars.
Other systems of similar design may be submitted to the Engineer for approval. Approval shall be based on certified test results from an approved testing laboratory that the proposed bar splicer assembly satisfies the following requirements:

- ① Minimum Capacity (Tension in kips) = $1.25 \times f_y \times A_l$
- ② Minimum Pull-out Strength (Tension in kips) = $1.25 \times f_{s_{allow}} \times A_l$

Where f_y = Yield strength of lapped reinforcement bars in ksi.
 $f_{s_{allow}}$ = Allowable tensile stress in lapped reinforcement bars in ksi (Service Load)
 A_l = Tensile stress area of lapped reinforcement bars.
* = 28 day concrete

Bar Size to be Spliced	Splicer Rod or Dowel Bar Length	Strength Requirements	
		Min. Capacity kips - tension	Min. Pull-Out Strength kips - tension
#5	2'-0"	23.0	9.2
#6	2'-7"	33.1	13.3
#7	3'-5"	45.1	18.0
#8	4'-6"	58.9	23.6

Bar splicer assemblies shall be according to Section 508 of the Standard Specifications, except as noted. The furnishing and installation of bar splicer assemblies will be measured and paid for at the contract unit price each for "BAR SPLICERS."

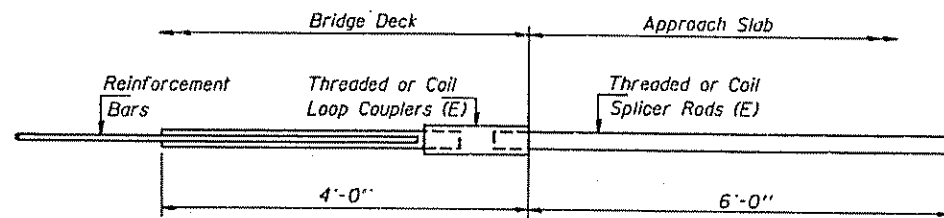

**INTEGRAL ABUTMENT
BAR SPLICER ASSEMBLY DETAIL
FOR #5 BAR**

Min. Capacity = 23.0 kips - tension
Min. Pull-out Strength = 9.2 kips - tension
No. Required =

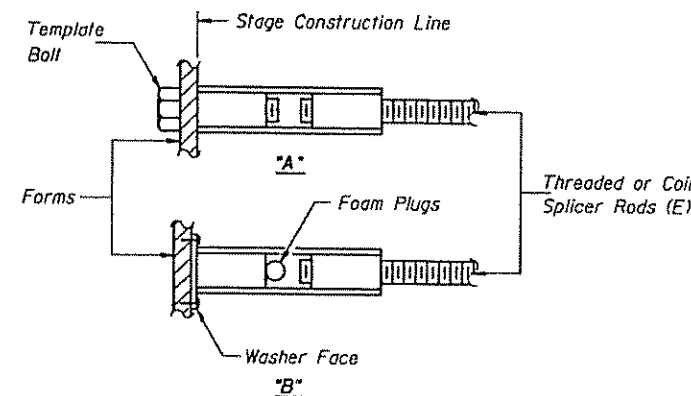

INSTALLATION AND SETTING METHODS

"A" : Set bar splicer assembly by means of a template bolt.
"B" : Set bar splicer assembly by nailing to wood forms or cementing to steel forms.
(E) : Indicates epoxy coating.

DESIGNED	20
CHECKED	EXAMINED
DRAWN	PASSED
CHECKED	

BSD-1 4-30-99

BAR SPLICER ASSEMBLY DETAILS
F.A.I. 55 OVER MONEY CREEK
SECTION (57-3-1,57-3,57-3-2,57-2) RS
McLEAN COUNTY
STA. 322+95
S.N. 057-0163 & S.N. 057-0164

F.A.I. RTE.	SECTION	COUNTY	TOTAL SHEETS	SHEET NO.
55	*	MCLEAN	139	177
STA.	TO STA.			
FED. ROAD DIST. NO.	ILLINOIS	FED. AID PROJECT		
* (57-3-1, 57-3, 57-3-2, 57-2) RS				

SHEET 1 of 7

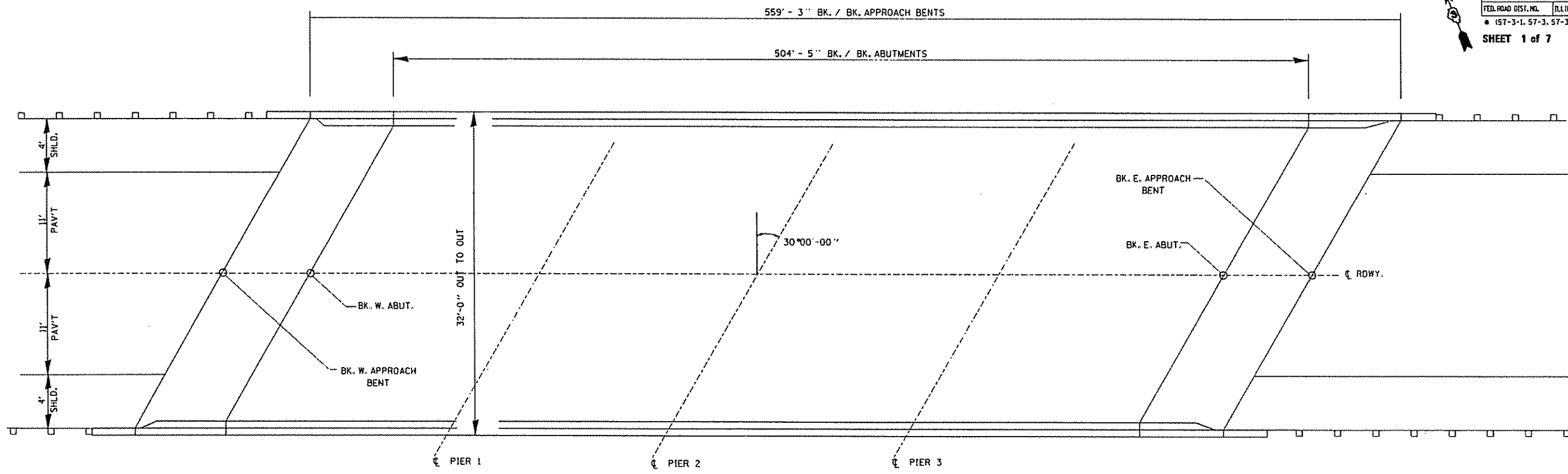

TOTAL BILL OF MATERIALS S.N. 057-0165			
CODE NO.	ITEM	UNIT	QUANT
44001000	BITUMINOUS CONCRETE REMOVAL (DECK)	SQ YD	1766
50102400	CONCRETE REMOVAL	CU YD	6
50300160	NEOPRENE EXPANSION JOINT 4"	FOOT	70
50300255	CONCRETE SUPERSTRUCTURE	CU YD	6
50300300	PROTECTIVE COAT	SQ YD	22
50301245	FORMED CONCRETE REPAIR (DEPTH LESS THAN OR EQUAL TO 5")	SO FT	30
50800205	REINFORCEMENT BARS, EPOXY COATED	POUND	1340
58100200	WATERPROOFING MEMBRANE SYSTEM	SQ YD	1748
59000100	EPOXY CRACK SEALING	FOOT	59
X0321468	PLUG EXISTING DECK DRAINS	EACH	16
X4066528	BIT. CONC. SURF. CSE., SUPERPAVE, MIX "D", N90	TON	152
Z0002600	BAR SPLICERS	EACH	20
Z0016001	DECK SLAB REPAIR (FULL DEPTH, TYPE I)	SQ YD	1
Z0016200	DECK SLAB REPAIR (PARTIAL)	SO YD	12
Z0047300	PROTECTIVE SHIELD	SQ YD	534

NOTE:
SEE SHEET 2 OF 7 FOR GENERAL NOTES.

S.N. 057-0165

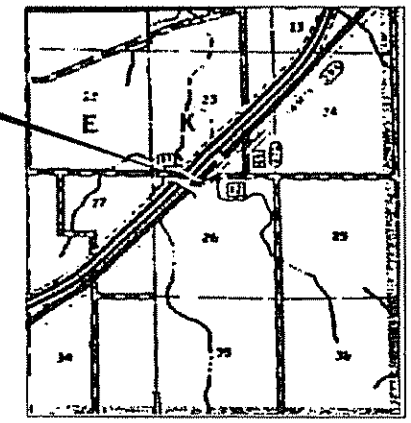

LOCATION SKETCH

GENERAL PLAN
CH. 12 OVER F.A.I. 55
SECTION (57-3-1, 57-3, 57-3-2, 57-2) RS
MCLEAN COUNTY
STA. 464 + 85.00
S.N. 057-0165

JAN. B. 2000
VED02100.DETA/LS.DGN

F.A.I. RTE.	SECTION	COUNTY	TOTAL SHEETS	SHEET NO.
55	*	MCLEAN	139	78
STA.	TO STA.			
FED. ROAD DIST. NO.		ILLINOIS	FED. AID PROJECT	
* (57-3-1, 57-3, 57-3-2, 57-2) RS				

SHEET 2 of 7

General Notes:

- All structural steel shall conform to AASHTO Classification M-270 Gr. 36 unless otherwise noted.
- All structural steel shall be shop painted with inorganic zinc rich primer per AASHTO M300, Type 1. The cost shall be included in the cost of Furnishing and Erecting Structural Steel.
- The existing structural steel contains lead. The Contractor should take appropriate precautions to deal with the presence of lead on this project.
- Reinforcement bars shall conform to the requirements of AASHTO M-31, M-42 or M-53 Grade 60.
- Any reinforcement bars that are damaged during concrete removal shall be replaced with an approved bar splicer or anchorage system. Cost shall be included in the cost of "Concrete Removal".
- Existing longitudinal reinforcement extending into the removed area shall be cleaned, straightened and incorporated into the new construction. Existing transverse reinforcement may be cut as shown and removed.
- Prior to pouring the new concrete for the deck, all loose rust, loose mill scale and all other loose, detrimental foreign material shall be removed from the portions of flanges of beams in contact with concrete. The removal shall be accomplished according to the requirements of the SSPC Surface Preparation Specifications SP-3 for power tool cleaning or SP-2 for hand tool cleaning. Cost shall be included in the cost of "Concrete Superstructure".
- Joint openings shall be adjusted according to Article 503.10(c) of the Standard Specifications when the deck is poured at an ambient temperature other than 50 degrees Fahrenheit.
- Plan dimensions and details relative to existing structure have been taken from existing plans and are subject to nominal construction variations. It shall be the Contractor's responsibility to verify such dimensions and details in the field and make necessary approved adjustments prior to construction or ordering of materials. Such variations shall not be cause for additional compensation for a change in the scope of the work, however, the Contractor will be paid for the quantity actually furnished at the unit price bid for the work.

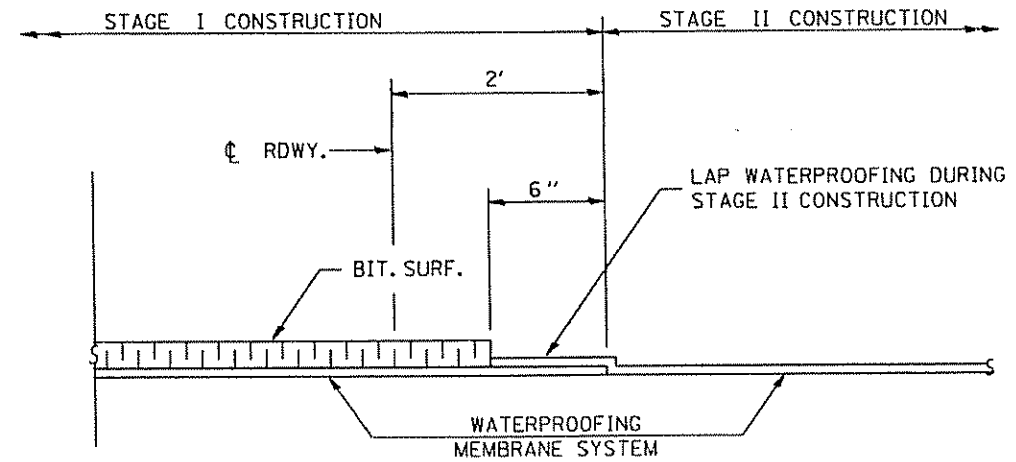

WATERPROOFING TREATMENT AT STAGE CONSTRUCTION

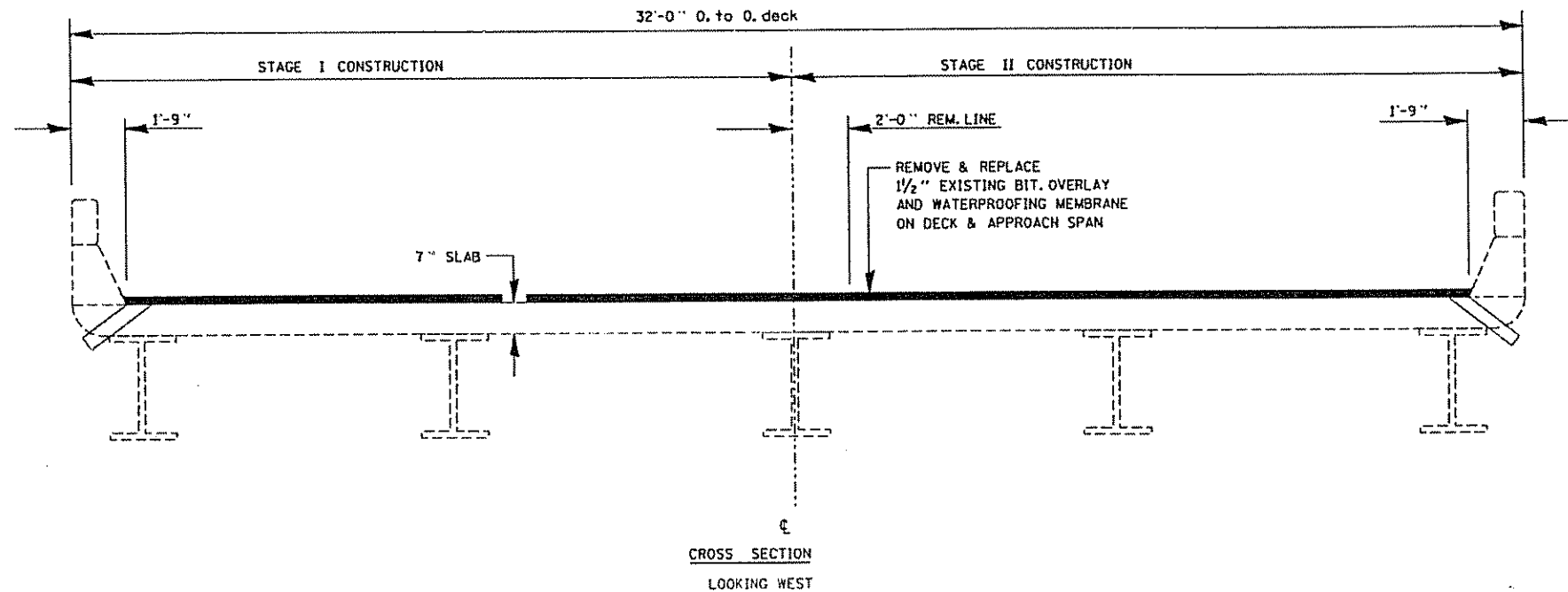

**GENERAL NOTES AND TYPICAL SECTION
CH. 12 OVER F.A.I. 55
SECTION (57-3-1, 57-3, 57-3-2, 57-2) RS
MCLEAN COUNTY
STA. 464 + 85.00
S.N. 057-0165**

F.A.I. RTE.	SECTION	COUNTY	TOTAL SHEETS	SHEET NO.
55	*	MCLEAN	139	79
STA.	TO STA.			
FED. ROAD DIST. NO.	ILLINOIS	FED. AID PROJECT		
* 57-3-1, 57-3, 57-3-2, 57-2) RS				

SHEET 3 of 7

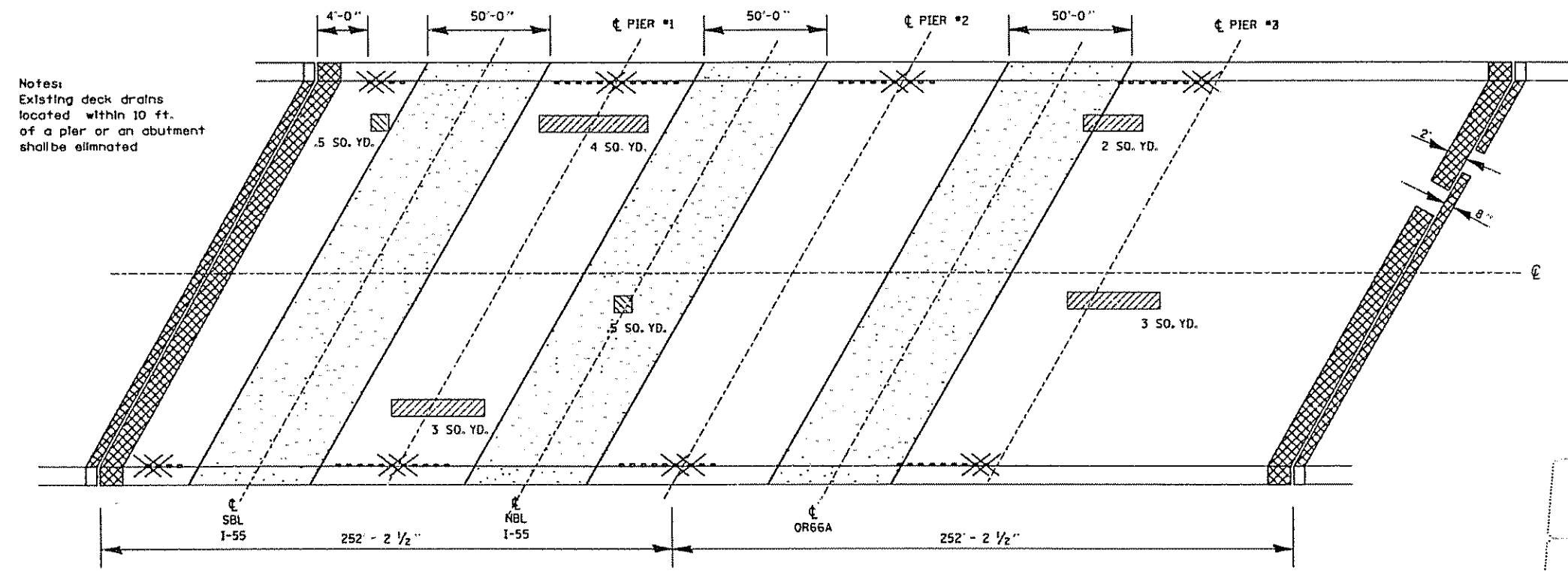

Notes:
Existing deck drains located within 10 ft. of a pier or an abutment shall be eliminated

NOTES:
AREA OF DECK REPAIRS SHOWN ARE ESTIMATED. THE ENGINEER SHALL SHOW ACTUAL LOCATIONS OF DECK REPAIRS ON AS-BUILT PLANS.
EXISTING DECK DRAINS LOCATED WITHIN 10 FT. OF A PIER OR AN ABUTMENT SHALL BE ELIMINATED.

	UNIT	STAGE I	STAGE II	TOTAL
CONC. REMOVAL	CU. YD.	3	3	6
CONC. SUPERSTRUCTURE	CU. YD.	3	3	6
PLUG EXISTING D. DRAINS	EACH	8	8	16
DECK SLAB REPAIR (PARTIAL DEPTH)	SO. YD.	6	6	12
DECK SLAB REPAIR (FULL DEPTH)	SO. YD.	.5	.5	1
PROTECTIVE SHIELD	SO. YD.	267	267	534

DECK SURVEY DATE: FEBRUARY 9, 1999

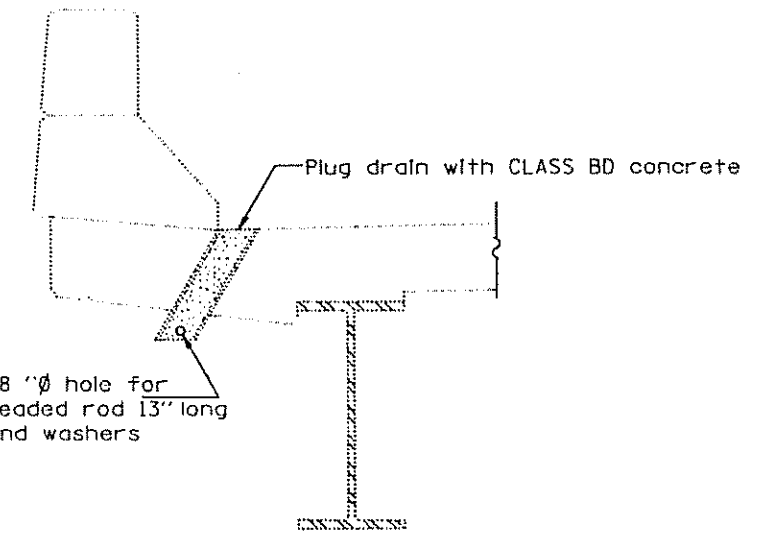

Field drill 3/8" hole for 1/4" threaded rod 13" long with nuts and washers

SECTION AT DRAIN
DRAIN ELIMINATION DETAILS

DECK REPAIR PLAN
CH. 12 OVER F.A.I. 55
SECTION (57-3-1, 57-3, 57-3-2, 57-2) RS
MCLEAN COUNTY
STA. 464 + 85.00
S.N. 057-0165

(309) 454-5619

F.A.I. RTE.	SECTION	COUNTY	TOTAL SHEETS	SHEET NO.
55		MCLEAN	139	80
STA.		TO STA.		
FED. ROAD DIST. NO.		ILLINOIS FED. AID PROJECT		
		* 57-3-1, 57-3, 57-3-2, 57-2) RS		

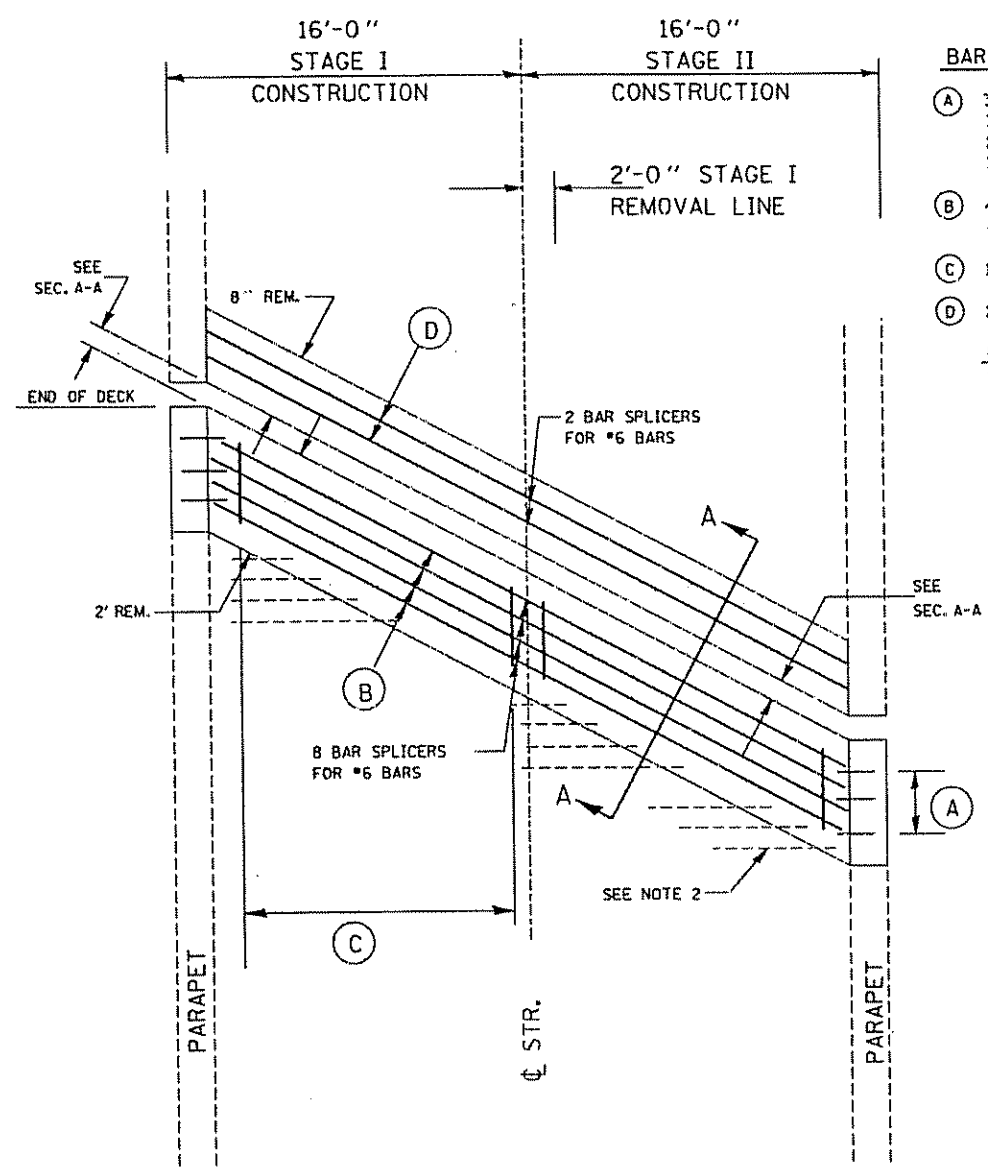

BARS REQUIRED FOR EACH STAGE

- (A) 3- #4 d (E) Bars
3- #5 d₁(E) Bars
2- #4 d₃(E) Bars @ ea. rail post
3- #6 a₁(E) Bars
 - (B) 4- #6 a (E) Bars (Top, Lap with a (E) Bars)
4- #6 a (E) Bars (Bottom)
 - (C) 14- #5 d₄(E) Bars @ 12" ctrs.
 - (D) 2- #6 a (E) Bars (Top)
- Min Bar Lap
#6 Bar 2'-7"

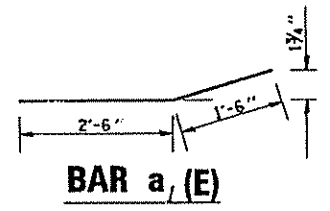
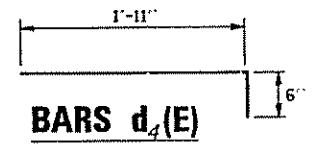
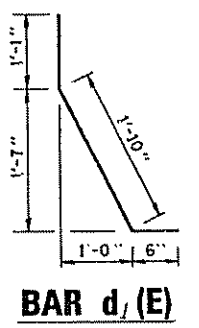
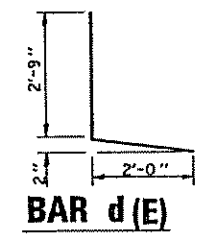
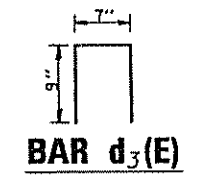

**PLAN AT WEST ABUTMENT
(EAST ABUTMENT MIRROR IMAGE)**

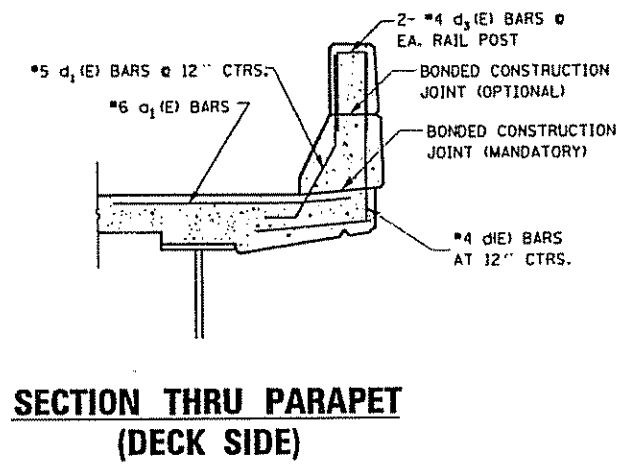
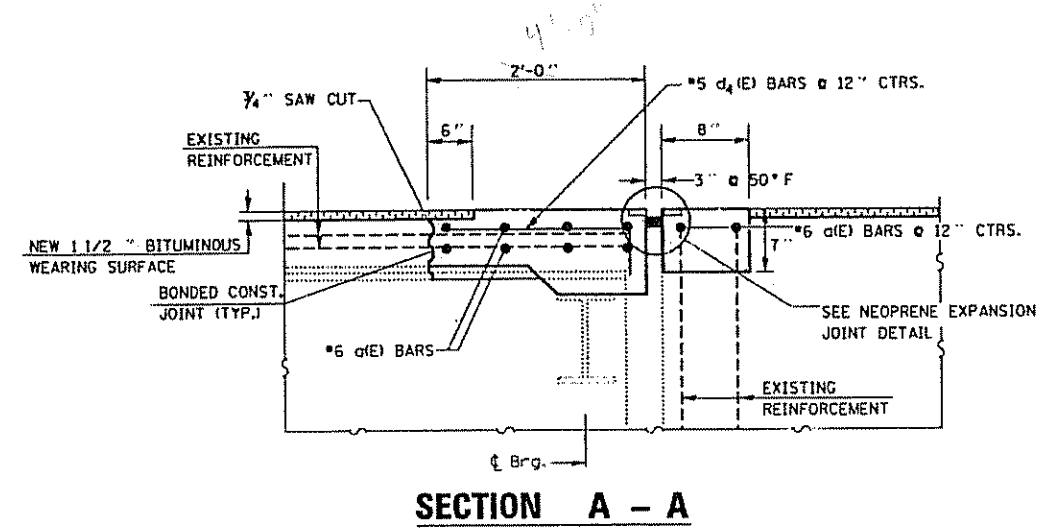

NOTES:

1. THE LIMITS OF ALL CONCRETE REMOVAL SHALL BE SAW CUT 3/4" INTO CONCRETE.
2. EXISTING TRANSVERSE BARS EXTENDING FROM DECK INTO REMOVED AREA SHALL BE CUT ALLOWING 2'-0" TO EXTEND INTO THE REMOVED AREA. IN ADDITION, THESE CUT BARS SHALL BE CLEANED, STRAIGHTENED, AND INCORPORATED INTO THE NEW CONSTRUCTION
3. EXISTING LONGITUDINAL BARS IN DECK AND VERTICAL BARS IN ABUTMENT BACKWALL EXTENDING INTO THE REMOVED AREA SHALL BE CLEANED, STRAIGHTENED, AND INCORPORATED IN THE NEW WORK.
4. EXISTING PARAPET REINFORCEMENT EXTENDING INTO THE REMOVED AREA SHALL BE CLEANED, STRAIGHTENED AND INCORPORATED INTO THE NEW CONSTRUCTION.
5. THE REMOVAL AND REPLACEMENT OF CONCRETE AT THE ABUTMENT BACKWALL, PARAPET, AND DECK WILL BE PAID FOR AS CONCRETE REMOVAL AND CONCRETE SUPERSTRUCTURE.
6. THE PARAPET SHALL BE REMOVED ON THE DECK SIDE, BUT SHALL REMAIN IN PLACE ON THE ABUTMENT SIDE. CONCRETE REMOVAL AT THE ABUTMENT SHALL BE FROM FACE OF PARAPET TO FACE OF PARAPET.
7. THE REMOVAL OF EXISTING PJS AND STEEL ARMOUR SHALL BE INCLUDED IN THE COST OF "CONCRETE REMOVAL".

BILL OF MATERIAL		SN 057-0165		
BAR	NO.	SIZE	LENGTH (FT.)	SHAPE
d(E)	40	#6	17'-7"	—
a1(E)	12	#6	4'-0"	—
d(E)	12	#4	2'-0"	┌
d1(E)	12	#5	3'-5"	┌
d3(E)	8	#4	2'-1"	┐
d4(E)	56	#5	2'-5"	┐
CONCRETE REMOVAL		CU YD	6	
CONC. SUPERSTRUCTURE		CU YD	6	
BAR SPLICERS		EACH	20	
REINFORCEMENT BARS. EPOXY COATED		POUND	1340	

REINFORCEMENT BARS DESIGNATED (E) SHALL BE EPOXY COATED

EXPANSION JOINT REPLACEMENT DETAILS
CH. 12 OVER F.A.I. 55
SECTION (57-3-1, 57-3, 57-3-2, 57-2) RS
MCLEAN COUNTY
STA. 464 + 85.00
S.N. 057-0165

F.A.I. RTE.	SECTION	COUNTY	TOTAL SHEETS	SHEET NO.
55	*	MCLEAN	159	81
STA.		TO STA.		
FED. ROAD DIST. NO.		ILLINOIS	FED. AID PROJECT	
		* 57-3-1, 57-3, 57-3-2, 57-21 RS		

SHEET 5 of 7

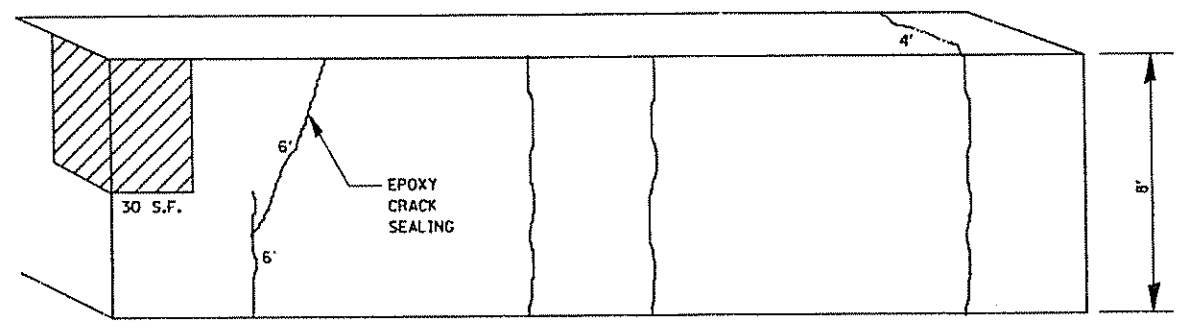

WEST ABUTMENT

EPOXY CRACK SEALING = 40'

FORMED CONCRETE REPAIR ≤ 5" = 30 S.F.

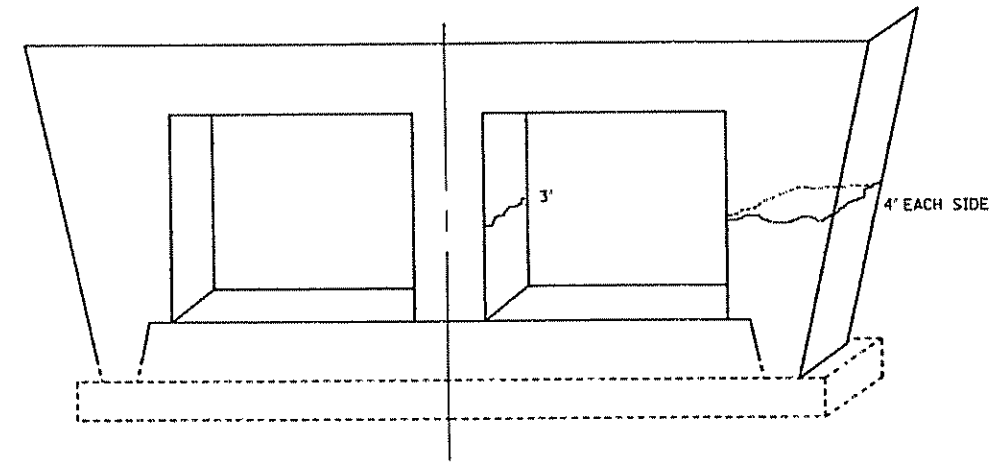

**EAST PIER
(EAST SIDE)**

EPOXY CRACK SEALING = 19'

EPOXY CRACK SEALING = 59'
FORMED CONCRETE REPAIR ≤ 5" = 30 S.F.

**ABUTMENT & PIER CRACKS AND SPALLS
S.N. 057-0165**

**ABUTMENT REPAIRS
CH. 12 OVER F.A.I. 55
SECTION (57-3-1, 57-3, 57-3-2, 57-2) RS
MCLEAN COUNTY
STA. 464 + 85.00
S.N. 057-0165**

STATE OF ILLINOIS
DEPARTMENT OF TRANSPORTATION

DATE NO.	SECTION	COUNT	DATE	BY	SHEET NO. 6 7 SHEETS
139	82				
MCCLEAN					

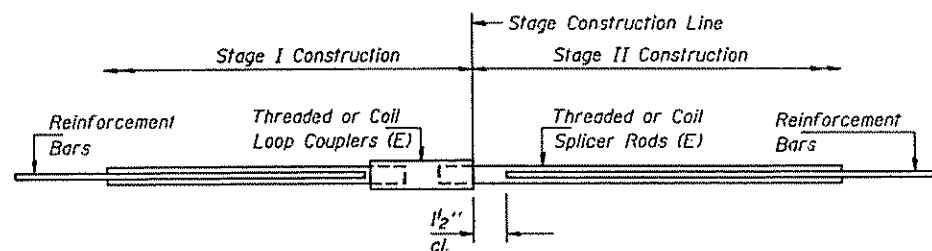

SPLICER DETAIL

Bar Size	No. Assemblies Required	Location
#6	20	Stage Const. Line

The diameter of this part is equal or larger than the diameter of bar spliced.

ROLLED THREAD DOWEL BAR



•• ONE PIECE

Wire Connector



WELDED SECTIONS

BAR SPLICER ASSEMBLY ALTERNATIVES

•• Heavy Hex Nuts conforming to ASTM A 563. Grade C, D or DH may be used.

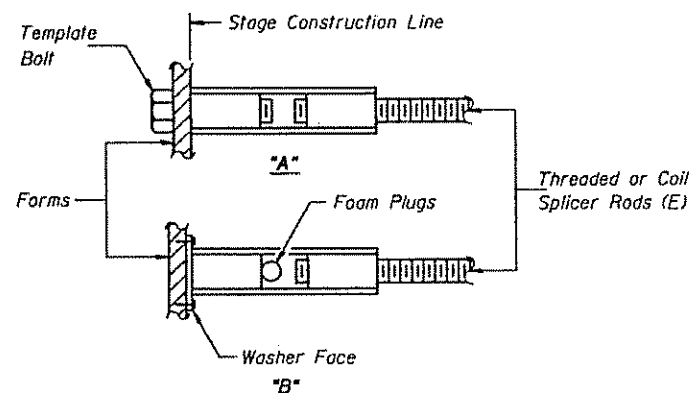

INSTALLATION AND SETTING METHODS

"A" : Set bar splicer assembly by means of a template bolt.
"B" : Set bar splicer assembly by nailing to wood forms or cementing to steel forms.
(E) : Indicates epoxy coating.

NOTES

Bar splicer assemblies shall be of an approved type and shall develop in tension at least 125 percent of the yield strength of the lapped reinforcement bars.
Splicer rods shall be of minimum 60 ksi yield strength, threaded or coiled full length.
All reinforcement bars shall be lapped and tied to the splicer rods or dowel bars.
Bar splicer assemblies shall be epoxy coated according to the requirements for reinforcement bars.
Other systems of similar design may be submitted to the Engineer for approval. Approval shall be based on certified test results from an approved testing laboratory that the proposed bar splicer assembly satisfies the following requirements:

- ① Minimum Capacity (Tension in kips) = $1.25 \times f_y \times A_l$
- ② Minimum *Pull-out Strength (Tension in kips) = $1.25 \times f_{s_{allow}} \times A_l$

Where f_y = Yield strength of lapped reinforcement bars in ksi.
 $f_{s_{allow}}$ = Allowable tensile stress in lapped reinforcement bars in ksi (Service Load)
 A_l = Tensile stress area of lapped reinforcement bars.
* = 28 day concrete

Bar Size to be Spliced	Splicer Rod or Dowel Bar Length	Strength Requirements	
		Min. Capacity kips - tension	Min. Pull-Out Strength kips - tension
#5	2'-0"	23.0	9.2
#6	2'-7"	33.1	13.3
#7	3'-5"	45.1	18.0
#8	4'-6"	58.9	23.6

Bar splicer assemblies shall be according to Section 508 of the Standard Specifications, except as noted. The furnishing and installation of bar splicer assemblies will be measured and paid for at the contract unit price each for "BAR SPLICERS."

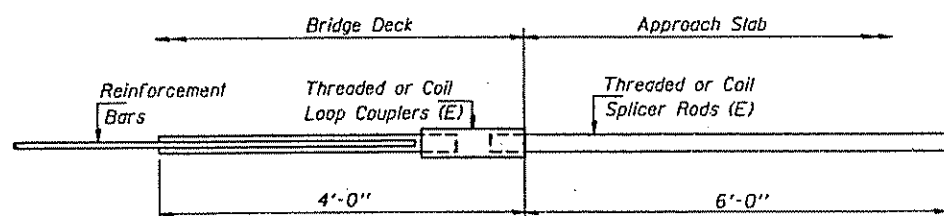

**INTEGRAL ABUTMENT
BAR SPLICER ASSEMBLY DETAIL
FOR #5 BAR**

Min. Capacity = 23.0 kips - tension
Min. Pull-out Strength = 9.2 kips - tension
No. Required =

DESIGNED	20
CHECKED	EXAMINED
DRAWN	ENGINEER OF BRIDGE DESIGN
CHECKED	PASSED
	ENGINEER OF BRIDGES AND STRUCTURES

BSD-1 4-30-99

BAR SPLICER ASSEMBLY DETAILS
CH. 12 OVER F.A.I. 55
SECTION (57-3-1,57-3,57-3-2,57-2) RS
McLEAN COUNTY
STA. 464 + 85.00
SN 057-0165

STATE OF ILLINOIS
DEPARTMENT OF TRANSPORTATION

Joint Size	"C" at 50°F	"D" at 50°F
2"	2"	1 1/2" Min.
2 1/2"	2 1/2"	1 3/4" Min.
4"	3"	2 1/2" Min.

INSTALLATION NOTES

- Install continuous seal in roadway, parapet, curb, and sidewalk.
- Install anchor blocks as indicated.

NOTE A: Maximum spacing of anchor bolts shall be 12" centers.

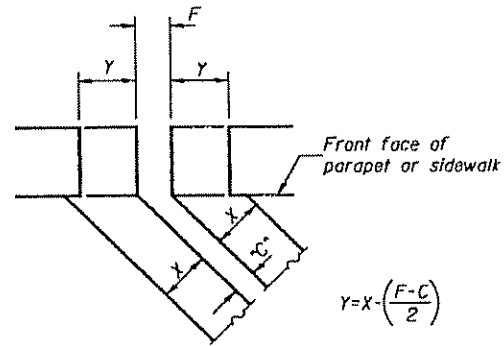

$$Y = X - \left(\frac{F - C}{2} \right)$$

For dimension "F" see sheet #

FORMING BLOCKOUT SKETCH

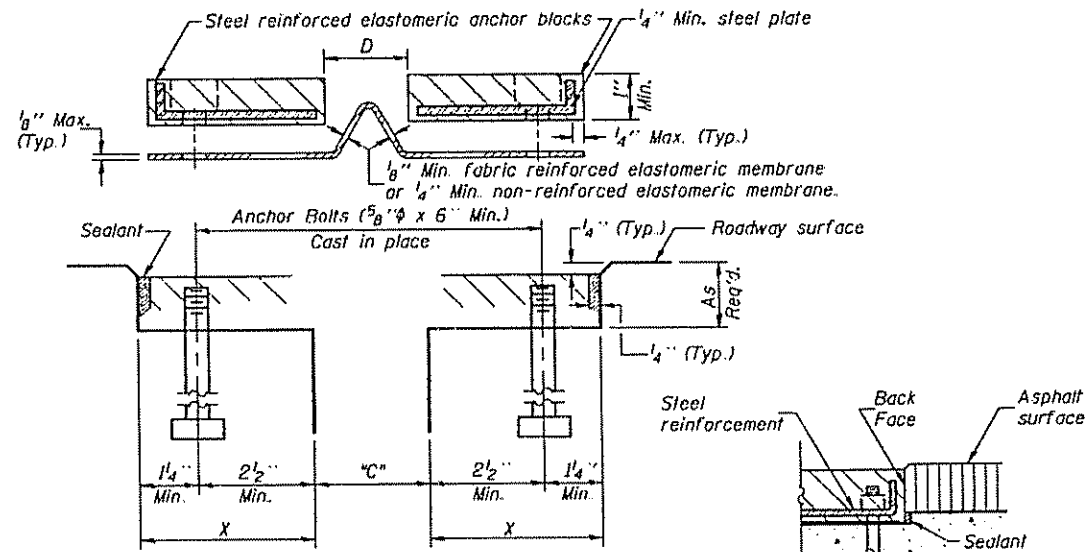

CROSS SECTION

ANCHOR BLOCK WITH ASPHALT SURFACE

GENERAL NOTES

Continuous Seal Neoprene Expansion Joint shall consist of molded anchor blocks of elastomer and steel, field assembled over continuous lengths of elastomeric membrane.

The elastomeric membrane shall be premolded with a single or a double upward convolution that will have a "memory" to return to its molded position upon joint closure.

The convolution length shall be such that the extended length will not be greater than the manufactured length when the joint is fully expanded in its design range and will not protrude above the anchor blocks when the joint is fully compressed.

Joint openings shall be adjusted according to Article 503.10(c) of the Standard Specifications when the deck is poured at an ambient temperature other than 50° F.

The parapet and roadway membrane shall be made continuous by an approved vulcanizing process. Lapping will not be permitted.

SKEW LIMITATIONS

The details of the anchor blocks and the elastomeric membrane in the parapet, as shown, are for up to 50° skews. For skews greater than 50°, the anchor blocks and the elastomeric membrane, installed according to dimension "D", might require modifications to insure a minimum clearance of 1 1/2" from centerline of anchor studs to edge of parapet opening. The anchor blocks and the elastomeric membrane shall also be installed to the top of the parapet with the anchor studs spaced at ±12" cts.

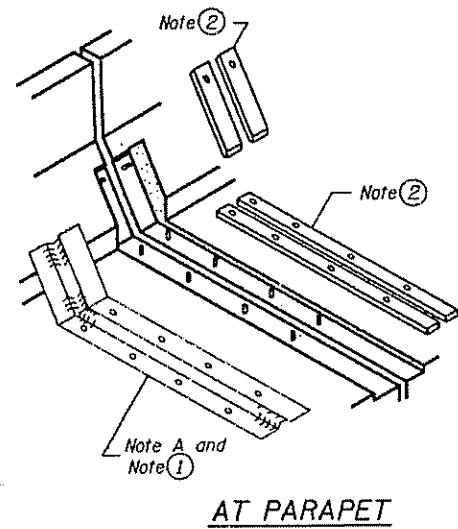

AT PARAPET

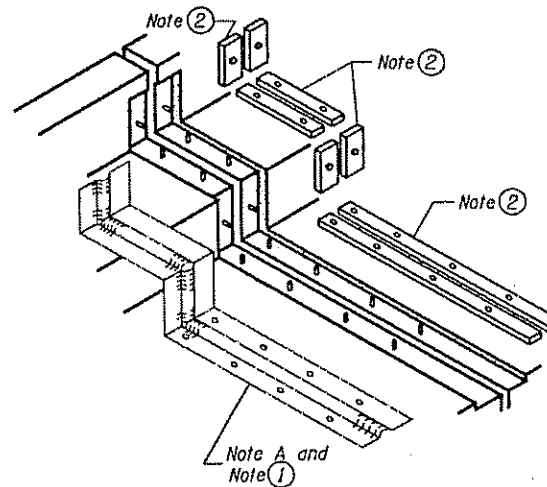

AT SIDEWALK OR MEDIAN

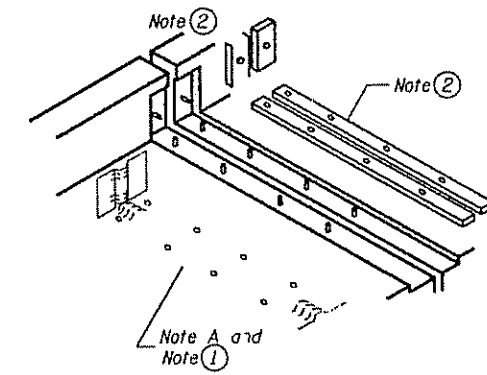

AT WALL

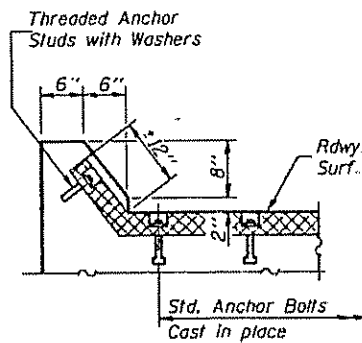

AT CURB

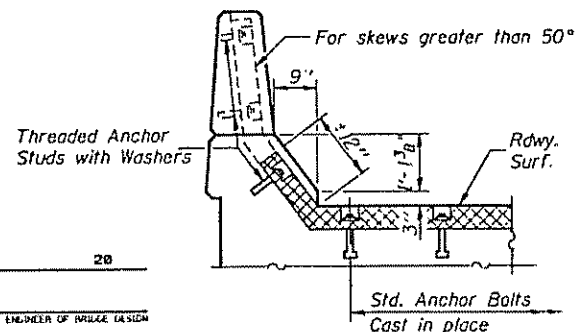

AT PARAPET

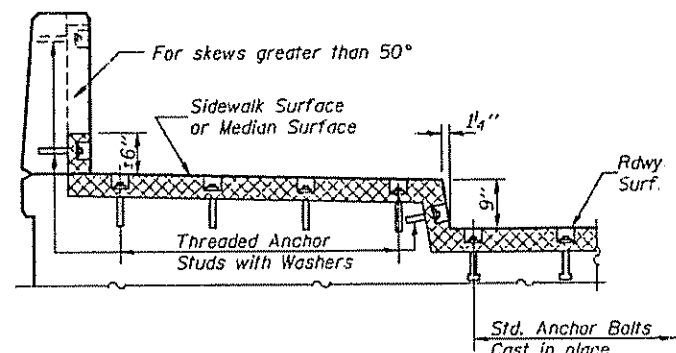

AT SIDEWALK OR MEDIAN TYPICAL END TREATMENTS

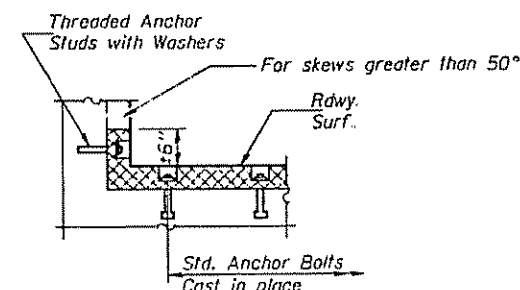

AT WALL

DESIGNED	28
CHECKED	EXAMINED
DRAWN	PASSED
CHECKED	

EJ-CS 4-30-97

CONTINUOUS SEAL TYPE NEOPRENE EXPANSION JOINTS
For 2", 2 1/2" and 4" Movement

CH. 12 OVER F.A.I. 55 SECTION (57-3-1,57-3,57-3-2,57-2) RS
McLEAN COUNTY
STA. 464 + 85.00
SN 057-0165

F.A.I. RTE.	SECTION	COUNTY	TOTAL SHEETS	SHEET NO.
55	■	MCLEAN	139	84
STA.		TO STA.		
FED. ROAD DIST. NO.		ILLINOIS FED. AID PROJECT		
157-3-1, 57-3, 57-3-2, 57-21 RS				

SHEET 1 of 6

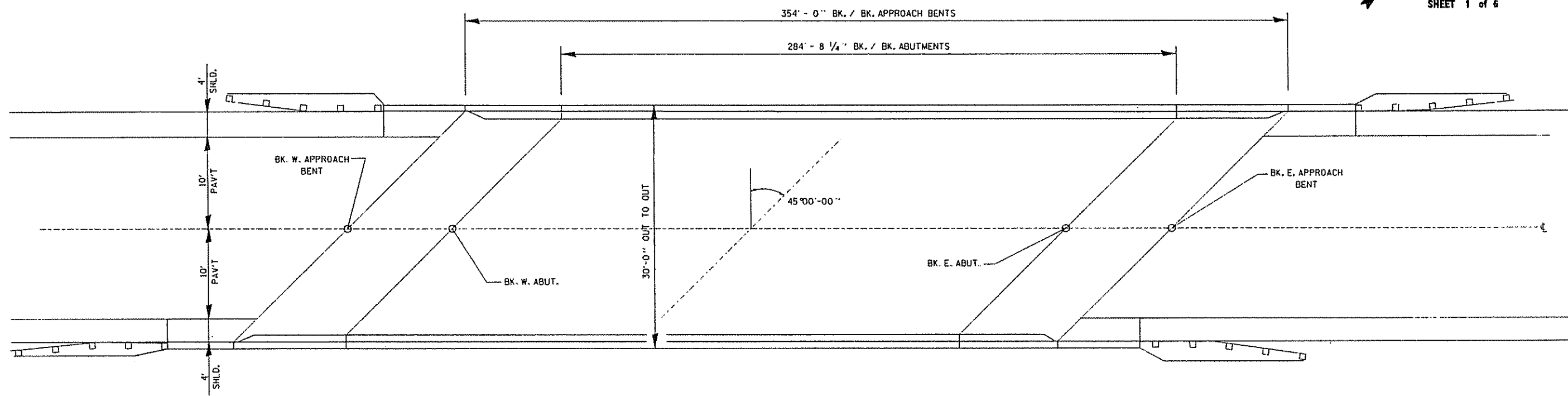

TOTAL BILL OF MATERIALS S.N. 057-0166			
CODE NO.	ITEM	UNIT	QUANT
44001000	BITUMINOUS CONCRETE REMOVAL (DECK)	SQ YD	1025
50102400	CONCRETE REMOVAL	CU YD	7
50300150	NEOPRENE EXPANSION JOINT 2"	FOOT	79
50300255	CONCRETE SUPERSTRUCTURE	CU YD	7
50300300	PROTECTIVE COAT	SQ YD	27
50800205	REINFORCEMENT BARS, EPOXY COATED	POUND	1495
58100200	WATERPROOFING MEMBRANE SYSTEM	SQ YD	1010
X0321468	PLUG EXISTING DECK DRAINS	EACH	4
X4066528	BIT. CONC. SURF. CSE., SUPERPAVE, MIX "D", N90	TON	88
Z0002600	BAR SPLICERS	EACH	20
Z0016001	DECK SLAB REPAIR (FULL DEPTH, TYPE I)	SQ YD	1
Z0016200	DECK SLAB REPAIR (PARTIAL)	SQ YD	1
Z0047300	PROTECTIVE SHIELD	SQ YD	400

NOTE:
SEE SHEET 2 OF 6 FOR GENERAL NOTES.

S.N. 057-0166

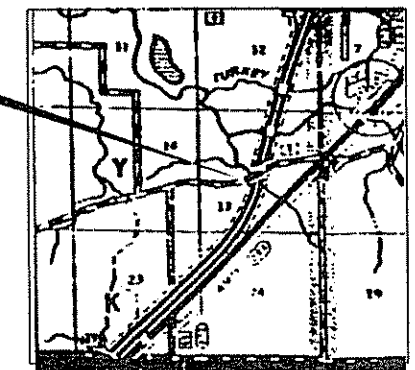

LOCATION SKETCH

GENERAL PLAN
T.R. 83 OVER F.A.I. 55
SECTION (57-3-1, 57-3, 57-3-2, 57-2) RS
MCLEAN COUNTY
STA. 571 + 30
S.N. 057-0166

F.A.I. RTE.	SECTION	COUNTY	TOTAL SHEETS	SHEET NO.
55	#	MCLEAN	139	85
STA.	TD STA.			
FED. ROAD DIST. NO.	ILLINOIS	FED. AID PROJECT		
# (57-3-1, 57-3, 57-3-2, 57-2) RS				

SHEET 2 of 6

General Notes

- All structural steel shall conform to AASHTO Classification M-270 Gr. 36 unless otherwise noted.
- All Structural steel shall be shop painted with inorganic zinc rich primer per AASHTO M300, Type 1. The cost shall be included in the cost of Furnishing and Erecting Structural Steel.
- The existing structural steel contains lead. The Contractor should take appropriate precautions to deal with the presence of lead on this project.
- Reinforcement bars shall conform to the requirements of AASHTO M-31, M-42 or M-53 Grade 60.
- Any reinforcement bars that are damaged during concrete removal shall be replaced with an approved bar splicer or anchorage system. Cost shall be included in the cost of "Concrete Removal".
- Existing longitudinal reinforcement extending into the removed area shall be cleaned, straightened and incorporated into the new construction. Existing transverse reinforcement may be cut as shown and removed.
- Prior to pouring the new concrete for the deck, all loose rust, loose mill scale and all other loose, detrimental foreign material shall be removed from the portions of flanges of beams in contact with concrete. The removal shall be accomplished according to the requirements of the SSPC Surface Preparation Specifications SP-3 for power tool cleaning or SP-2 for hand tool cleaning. Cost shall be included in the cost of "Concrete Superstructure".
- Joint openings shall be adjusted according to Article 503.10(c) of the Standard Specifications when the deck is poured at an ambient temperature other than 50 degrees Fahrenheit.
- Plan dimensions and details relative to existing structure have been taken from existing plans and are subject to nominal construction variations. It shall be the Contractor's responsibility to verify such dimensions and details in the field and make necessary approved adjustments prior to construction or ordering of materials. Such variations shall not be cause for additional compensation for a change in the scope of the work, however, the Contractor will be paid for the quantity actually furnished at the unit price bid for the work.

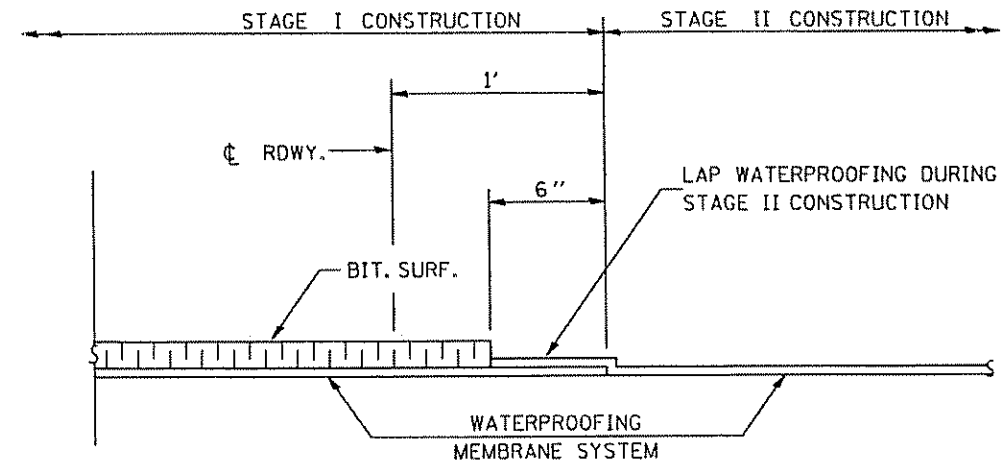

WATERPROOFING TREATMENT AT STAGE CONSTRUCTION

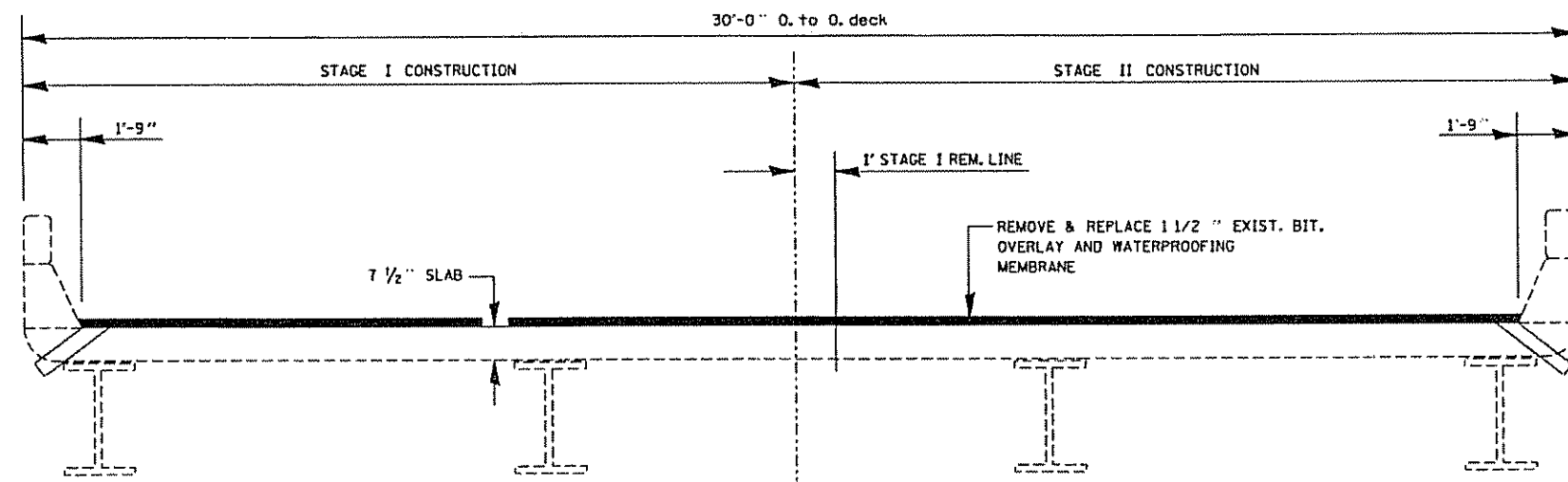

CROSS SECTION LOOKING WEST

**GENERAL NOTES AND TYPICAL SECTION
T.R. 83 OVER F.A.I. 55
SECTION (57-3-1, 57-3, 57-3-2, 57-2) RS
MCLEAN COUNTY
STA. 571+30
S.N. 057-0166**

JAH, B, 2000
VED02100VDETAILS.DGN

F.A.I. RTE.	SECTION	COUNTY	TOTAL SHEETS	SHEET NO.
55	♦	MCLEAN	139	86
STA.	TO STA.			
FED. ROAD DIST. NO.	ILLINOIS	FED. AID PROJECT		
♦ 57-3-1, 57-3, 57-3-2, 57-21 RS				

SHEET 3 of 6

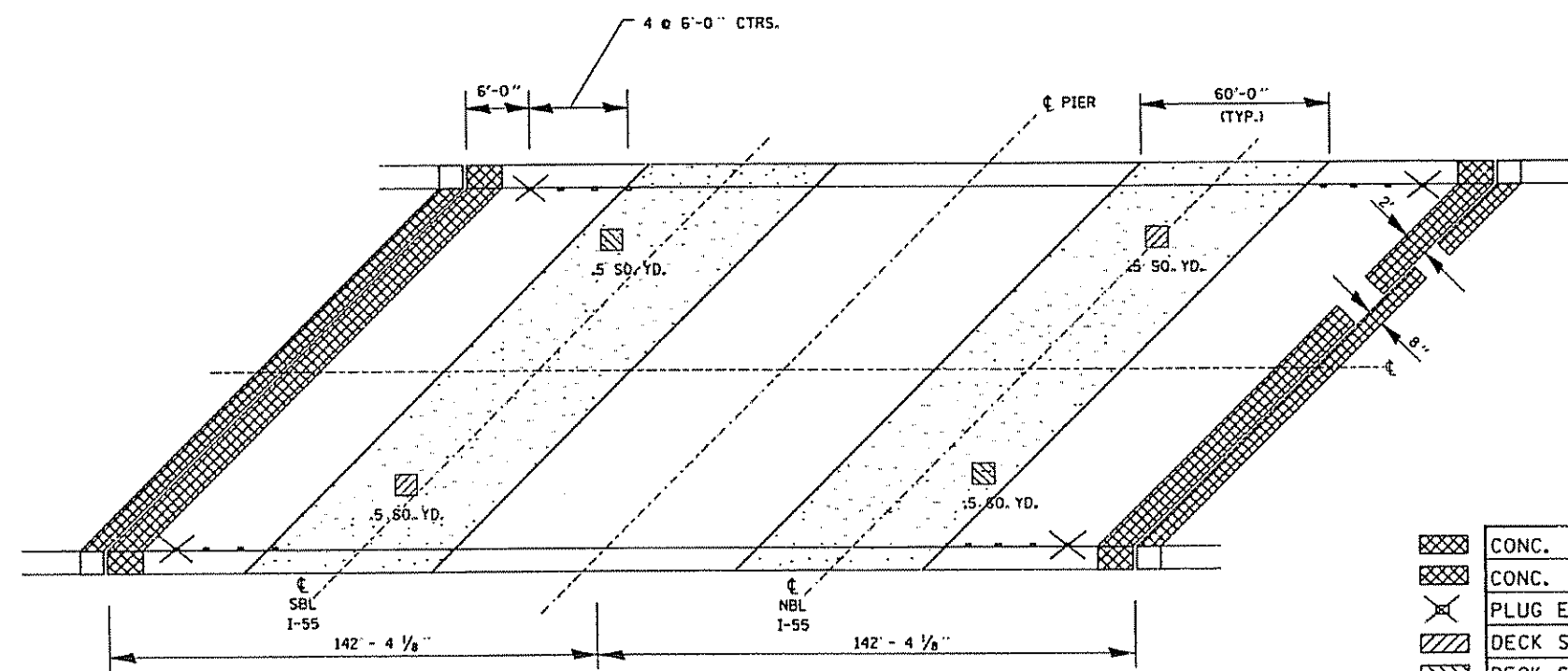

NOTES:
 AREA OF DECK REPAIRS SHOWN ARE ESTIMATED. THE ENGINEER SHALL SHOW ACTUAL LOCATIONS OF DECK REPAIRS ON AS-BUILT PLANS.
 EXISTING DECK DRAINS LOCATED WITHIN 10 FT. OF A PIER OR AN ABUTMENT SHALL BE ELIMINATED.

	UNIT	STAGE I	STAGE II	TOTAL
CONC. REMOVAL	CU. YD.	3.5	3.5	7
CONC. SUPERSTRUCTURE	CU. YD.	3.5	3.5	7
PLUG EXISTING DECK DRAINS	EACH	2	2	4
DECK SLAB REPAIR (PARTIAL DEPTH)	SQ. YD.	.5	.5	1
DECK SLAB REPAIR (FULL DEPTH)	SQ. YD.	.5	.5	1
PROTECTIVE SHIELD	SQ. YD.	200	200	400

DECK SURVEY DATE: FEBRUARY 9, 1999

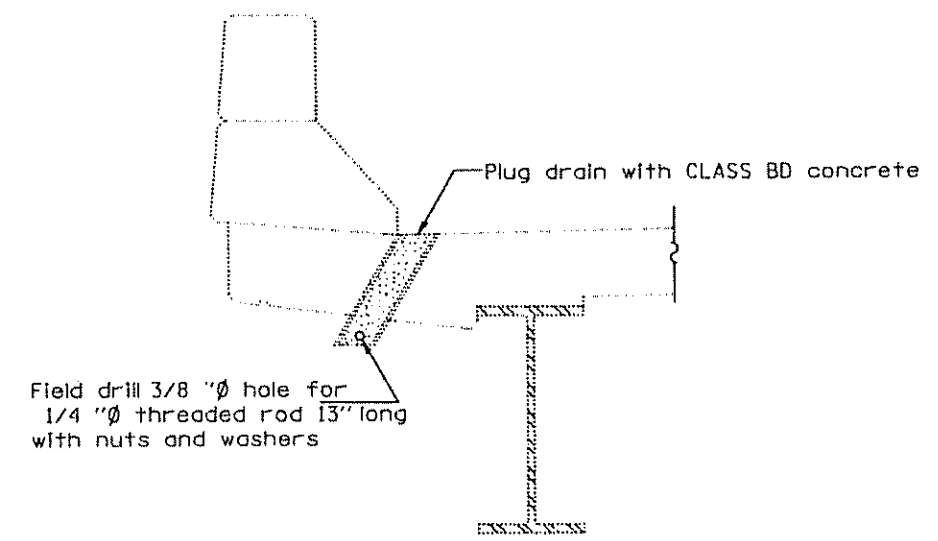

SECTION AT DRAIN
DRAIN ELIMINATION DETAILS

DECK REPAIR PLAN
T.R. 83 OVER F.A.I. 55
SECTION (57-3-1, 57-3, 57-3-2, 57-2) RS
MCLEAN COUNTY
STA. 571 + 30
S.N. 057-0166

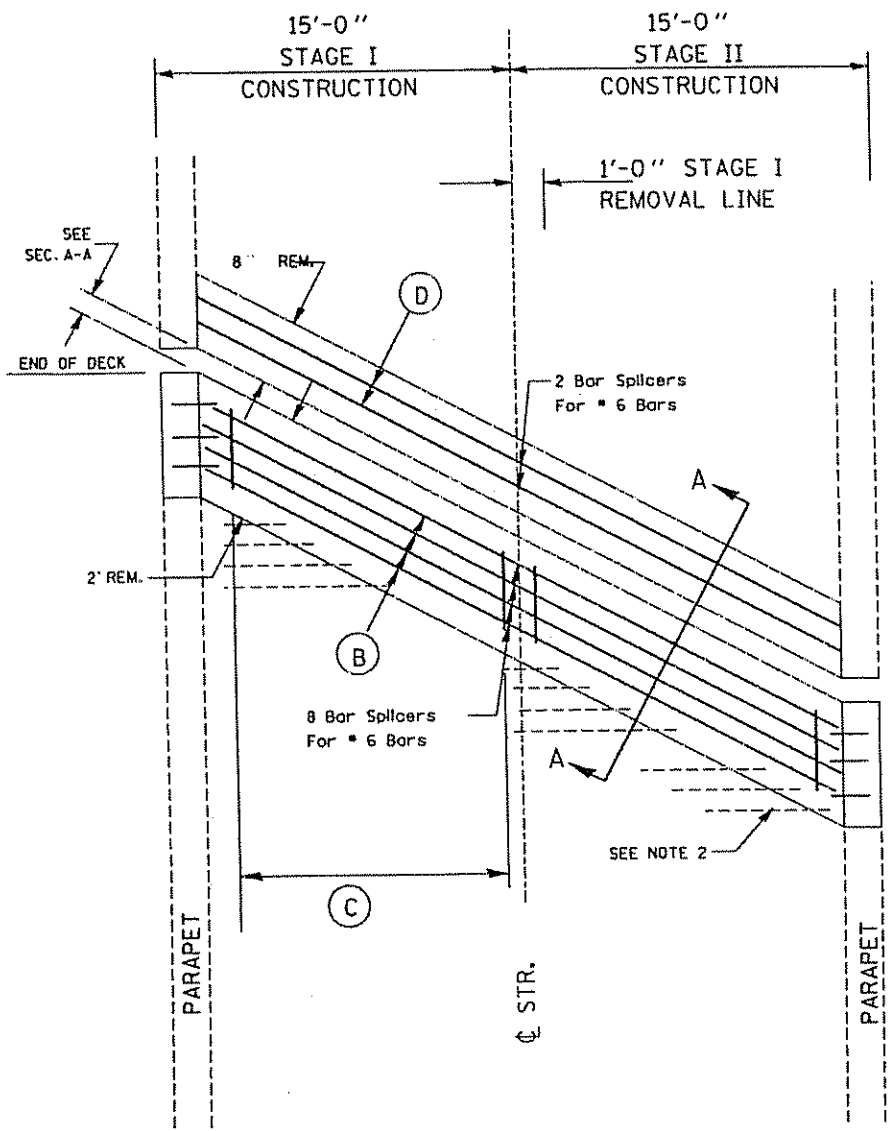

BARS REQUIRED FOR EACH STAGE

- (A) 3- #4 d(E) Bars
3- #5 d₁(E) Bars
2- #4 d₃(E) Bars @ ea. railpost
3- #6 d₁(E) Bars (Top, Lap with d(E) bars)
- (B) 4- #6 a(E) Bars (Top)
4- #6 a(E) Bars (Bottom)
- (C) 14- #5 d₄(E) Bars @ 12" ctrs.
- (D) 2- #6 a(E) Bar (Top)

Min Bar Lap
#6 Bar 2'-7"

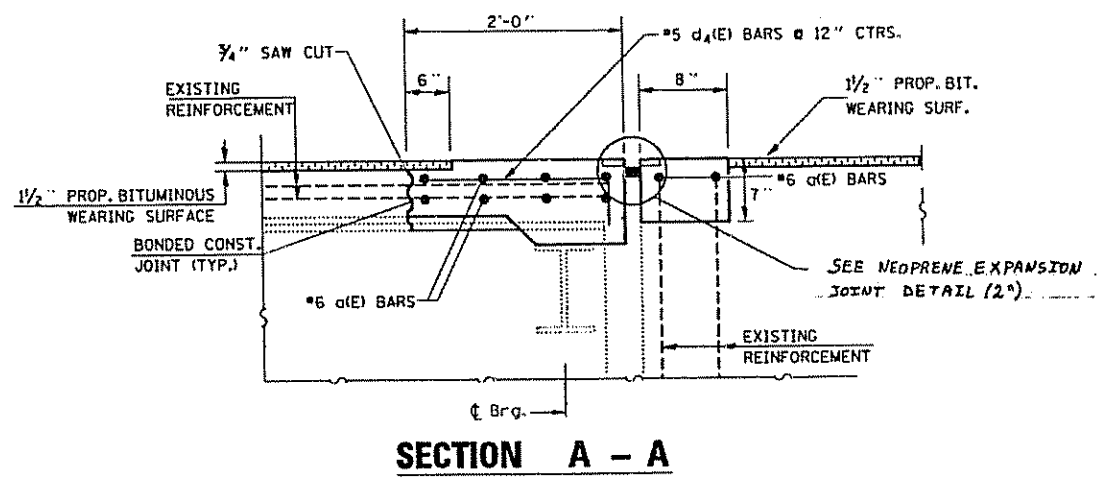
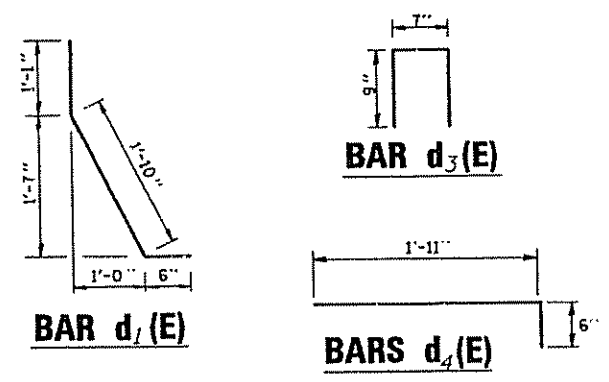

NOTES:

1. THE LIMITS OF ALL CONCRETE REMOVAL SHALL BE SAW CUT 3/4" INTO CONCRETE.
2. EXISTING TRANSVERSE BARS EXTENDING FROM DECK INTO REMOVED AREA SHALL BE CUT ALLOWING 2'-0" TO EXTEND INTO THE REMOVED AREA. IN ADDITION, THESE CUT BARS SHALL BE CLEANED, STRAIGHTENED, AND INCORPORATED INTO THE NEW CONSTRUCTION.
3. EXISTING LONGITUDINAL BARS IN DECK AND VERTICAL BARS IN ABUTMENT BACKWALL EXTENDING INTO THE REMOVED AREA SHALL BE CLEANED, STRAIGHTENED, AND INCORPORATED IN THE NEW WORK.
4. EXISTING PARAPET REINFORCEMENT EXTENDING INTO THE REMOVED AREA SHALL BE CLEANED, STRAIGHTENED AND INCORPORATED INTO THE NEW CONSTRUCTION.
5. THE REMOVAL AND REPLACEMENT OF CONCRETE AT THE APPROACH SLAB, PARAPET, AND DECK WILL BE PAID FOR AS CONCRETE REMOVAL AND CONCRETE SUPERSTRUCTURE.
6. THE PARAPET SHALL BE REMOVED ON THE DECK SIDE, BUT SHALL REMAIN IN PLACE ON THE ABUTMENT SIDE. CONCRETE REMOVAL AT THE ABUTMENT SHALL BE FROM FACE OF PARAPET TO FACE OF PARAPET.
7. THE REMOVAL OF EXISTING NEOPRENE JOINT SEAL SHALL BE INCLUDED IN THE COST OF "CONCRETE REMOVAL".
8. THE CONTRACTOR SHOULD EXERCISE EXTREME CARE NOT TO DAMAGE EXISTING PPC I BEAMS DURING CONCRETE REMOVAL.

**PLAN AT WEST ABUTMENT
(EAST ABUTMENT MIRROR IMAGE)**

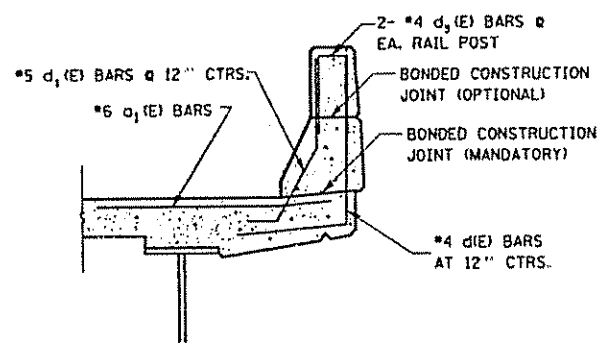

**SECTION THRU PARAPET
(DECK SIDE)**

BILL OF MATERIAL		SN 057-0166		
BAR	NO.	SIZE	LENGTH (FT.)	SHAPE
a(E)	40	#6	20' - 2"	—
a1(E)	12	#6	4' - 0"	—
d(E)	12	#4	2' - 0"	L
d1(E)	12	#5	3' - 5"	L
d3(E)	8	#4	2' - 1"	□
d4(E)	56	#5	2' - 5"	—
CONCRETE REMOVAL		CU YD	7	
CONC. SUPERSTRUCTURE		CU YD	7	
BAR SPLICERS		EACH	20	
REINFORCEMENT BARS, EPOXY COATED		POUND	1495	

REINFORCEMENT BARS DESIGNATED (E) SHALL BE EPOXY COATED

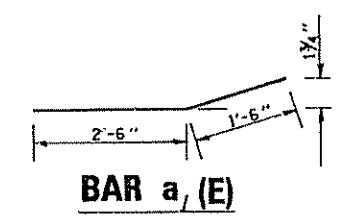
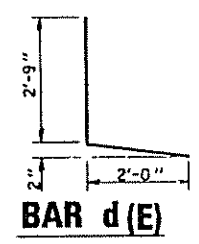

EXPANSION JOINT REPLACEMENT DETAILS
T.R. 83 OVER F.A.I. 55
SECTION (57-3-1, 57-3, 57-3-2, 57-2) RS
MCLEAN COUNTY
STA. 571+30
S.N. 057-0166

STATE OF ILLINOIS
DEPARTMENT OF TRANSPORTATION

Joint Size	"C" at 50°F	"D" at 50°F
2"	2"	1 1/2" Min.
2 1/2"	2 1/2"	1 3/4" Min.
4"	3"	2 1/2" Min.

INSTALLATION NOTES

- Install continuous seal in roadway, parapet, curb, and sidewalk.
 - Install anchor blocks as indicated.
- NOTE A: Maximum spacing of anchor bolts shall be 12" centers.

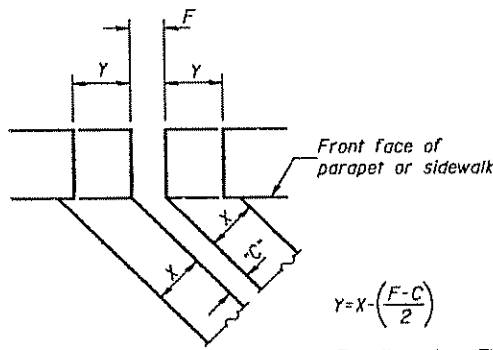

$$Y = X \left(\frac{F-C}{2} \right)$$

For dimension "F" see sheet #

FORMING BLOCKOUT SKETCH

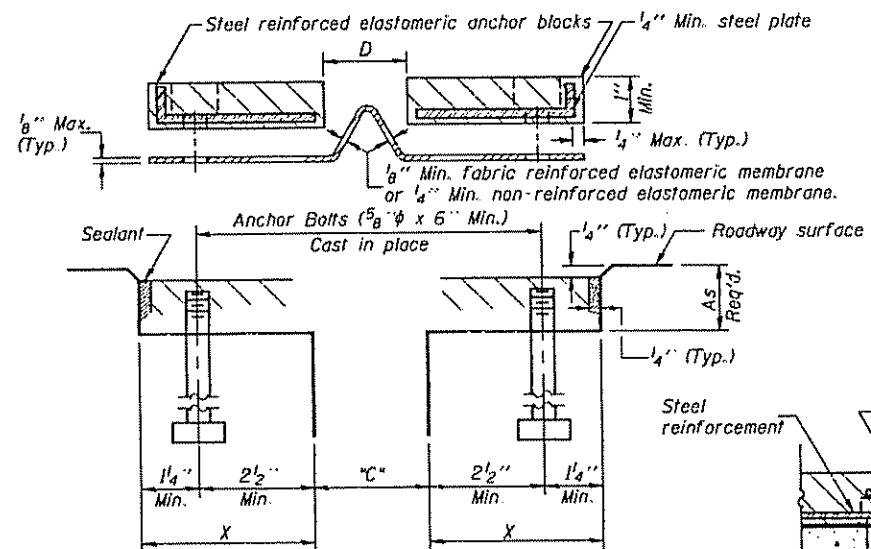

CROSS SECTION

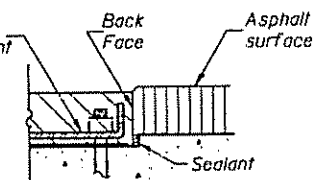

ANCHOR BLOCK WITH ASPHALT SURFACE

GENERAL NOTES

Continuous Seal Neoprene Expansion Joint shall consist of molded anchor blocks of elastomer and steel field assembled over continuous lengths of elastomeric membrane.

The elastomeric membrane shall be premolded with a single or a double upward convolution that will have a "memory" to return to its molded position upon joint closure.

The convolution length shall be such that the extended length will not be greater than the manufactured length when the joint is fully expanded in its design range and will not protrude above the anchor blocks when the joint is fully compressed.

Joint openings shall be adjusted according to Article 503.10(c) of the Standard Specifications when the deck is poured at an ambient temperature other than 50° F.

The parapet and roadway membrane shall be made continuous by an approved vulcanizing process. Lapping will not be permitted.

SKEW LIMITATIONS

The details of the anchor blocks and the elastomeric membrane in the parapet, as shown, are for up to 50° skews. For skews greater than 50°, the anchor blocks and the elastomeric membrane, installed according to dimension "D", might require modifications to insure a minimum clearance of 1/2" from centerline of anchor studs to edge of parapet opening. The anchor blocks and the elastomeric membrane shall also be installed to the top of the parapet with the anchor studs spaced at ±12" cts.

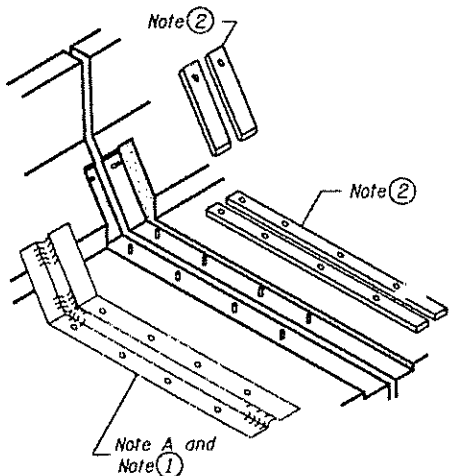

AT PARAPET

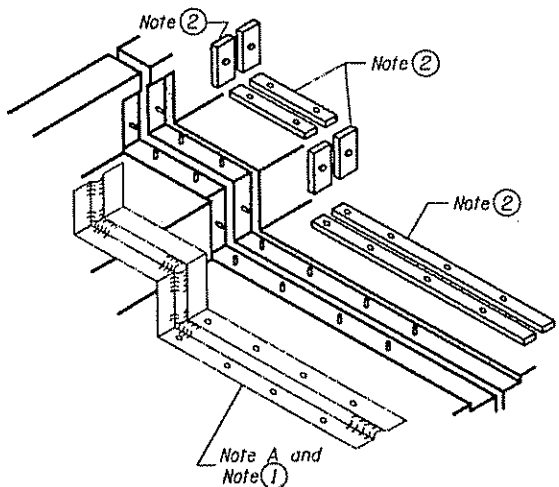

AT SIDEWALK OR MEDIAN

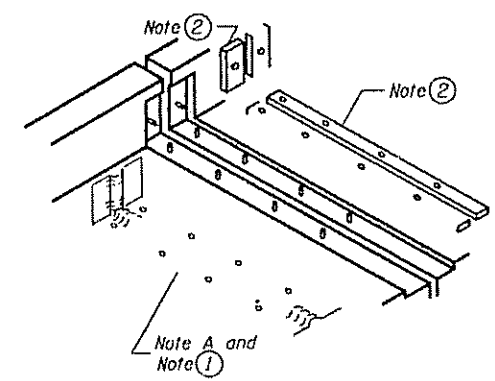

AT WALL

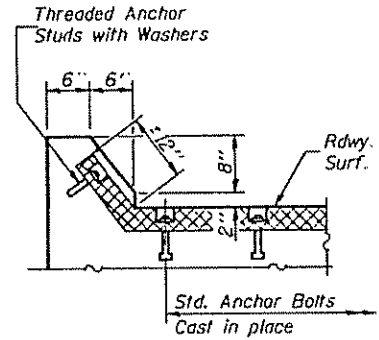

AT CURB

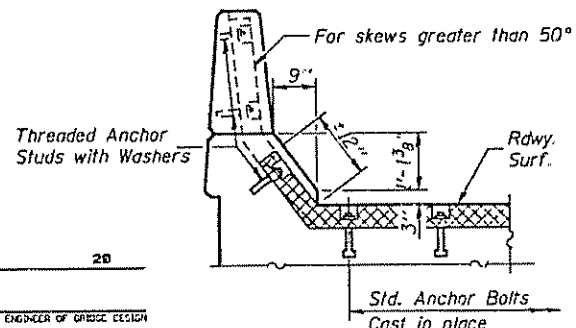

AT PARAPET

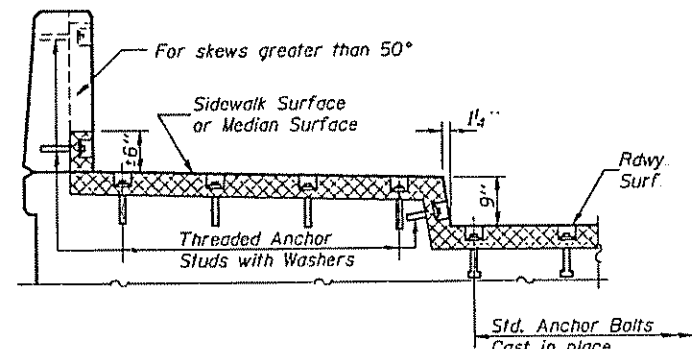

AT SIDEWALK OR MEDIAN TYPICAL END TREATMENTS

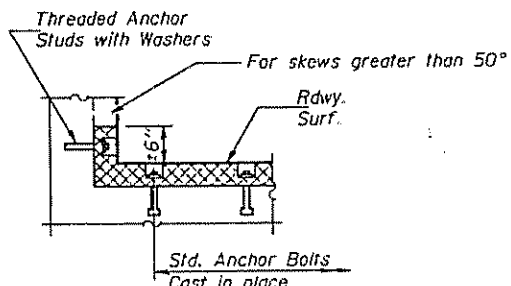

AT WALL

CONTINUOUS SEAL TYPE NEOPRENE EXPANSION JOINTS
For 2", 2 1/2" and 4" Movement

T.R. 83 OVER F.A.I. 55
SECTION (57-3-1.57-3.57-3-2.57-2) RS
McLEAN COUNTY
STA. 571+30
SN 057-0166

DESIGNED	20
CHECKED	EXAMINED
DRAWN	PASSED
CHECKED	ENGINEER OF BRIDGES AND STRUCTURES

EJ-CS 4-30-97

STATE OF ILLINOIS
DEPARTMENT OF TRANSPORTATION

PROJECT NO.	SECTION	LENGTH	TOTAL SHEETS	SHEET NO.
		MCLEAN	139	89
SHEET NO. 6 6 SHEETS				

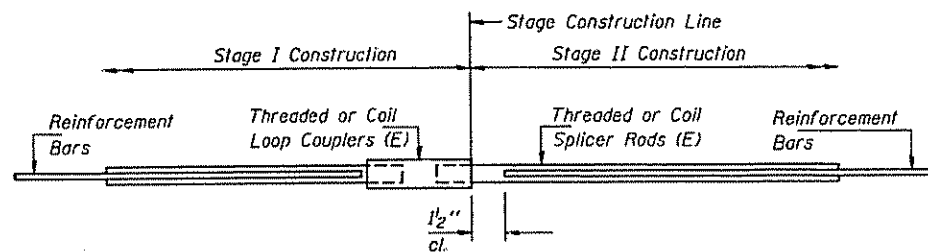

SPLICER DETAIL

Bar Size	No. Assemblies Required	Location
#6	20	Stage Const. Line

The diameter of this part is the same as the diameter of the bar spliced.

ROLLED THREAD DOWEL BAR



ONE PIECE

Wire Connector



WELDED SECTIONS

BAR SPLICER ASSEMBLY ALTERNATIVES

** Heavy Hex Nuts conforming to ASTM A 563, Grade C, D or DH may be used.

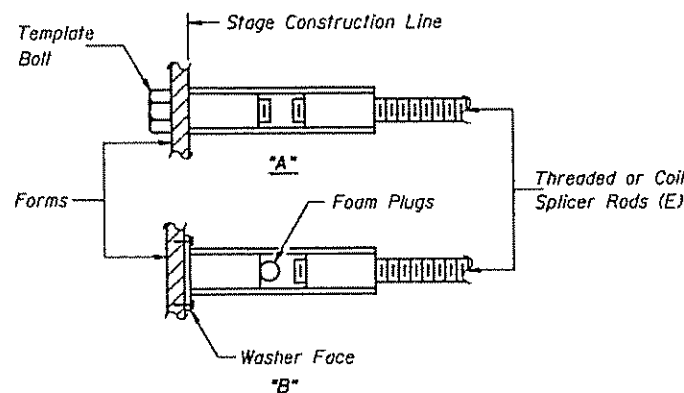

INSTALLATION AND SETTING METHODS

"A": Set bar splicer assembly by means of a template bolt.
"B": Set bar splicer assembly by nailing to wood forms or cementing to steel forms.
(E) : Indicates epoxy coating.

NOTES

Bar splicer assemblies shall be of an approved type and shall develop in tension at least 125 percent of the yield strength of the lapped reinforcement bars.
Splicer rods shall be of minimum 60 ksi yield strength, threaded or coiled full length.
All reinforcement bars shall be lapped and tied to the splicer rods or dowel bars.
Bar splicer assemblies shall be epoxy coated according to the requirements for reinforcement bars.
Other systems of similar design may be submitted to the Engineer for approval. Approval shall be based on certified test results from an approved testing laboratory that the proposed bar splicer assembly satisfies the following requirements:

- ① Minimum Capacity (Tension in kips) = $1.25 \times f_y \times A_t$
- ② Minimum *Pull-out Strength (Tension in kips) = $1.25 \times f_{s_{allow}} \times A_t$

Where f_y = Yield strength of lapped reinforcement bars in ksi.
 $f_{s_{allow}}$ = Allowable tensile stress in lapped reinforcement bars in ksi (Service Load)
 A_t = Tensile stress area of lapped reinforcement bars.
* = 28 day concrete

Bar Size to be Spliced	Splicer Rod or Dowel Bar Length	Strength Requirements	
		Min. Capacity kips - tension	Min. Pull-Out Strength kips - tension
#5	2'-0"	23.0	9.2
#6	2'-7"	33.1	13.3
#7	3'-5"	45.1	18.0
#8	4'-6"	58.9	23.6

Bar splicer assemblies shall be according to Section 508 of the Standard Specifications, except as noted. The furnishing and installation of bar splicer assemblies will be measured and paid for at the contract unit price each for "BAR SPLICERS."

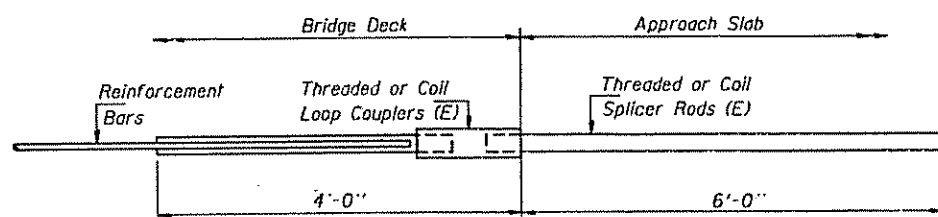

**INTEGRAL ABUTMENT
BAR SPLICER ASSEMBLY DETAIL
FOR #5 BAR**

Min. Capacity = 23.0 kips - tension
Min. Pull-out Strength = 9.2 kips - tension
No. Required =

DESIGNED	20
CHECKED	EXAMINED
DRAWN	PASSED
CHECKED	ENGINEER OF BRIDGES AND STRUCTURES

BSD-1 4-30-99

BAR SPLICER ASSEMBLY DETAILS
T.R. 83 OVER F.A.I. 55
SECTION (57-3-1,57-3,57-3-2,57-2) RS
McLEAN COUNTY
STA. 571 + 30
SN 057-0166

F.A.I. RYE	SECTION	COUNTY	TOTAL SHEETS	SHEET NO.
55	*	MCLEAN	139	90
STA.		TO STA.		
FED. ROAD DIST. NO.		ILLINOIS FED. AID PROJECT		
* 57-3-1, 57-3, 57-3-2, 57-21 RS				

SHEET 1 of 18

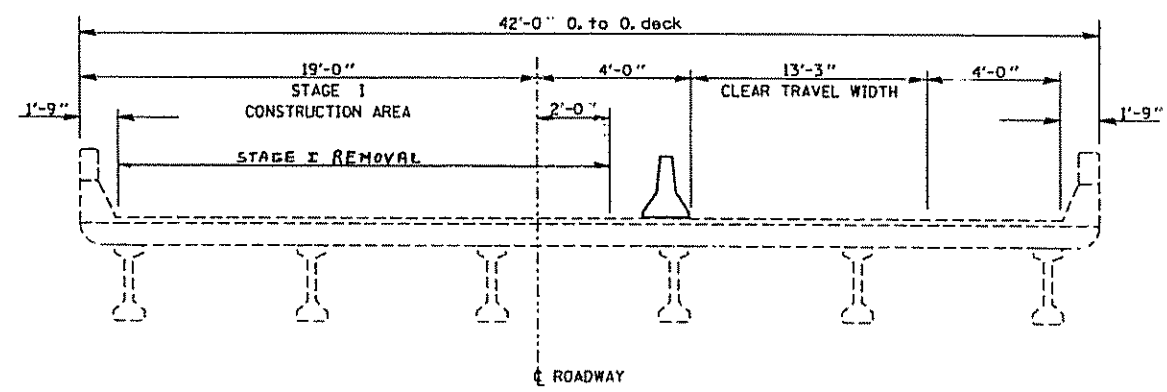
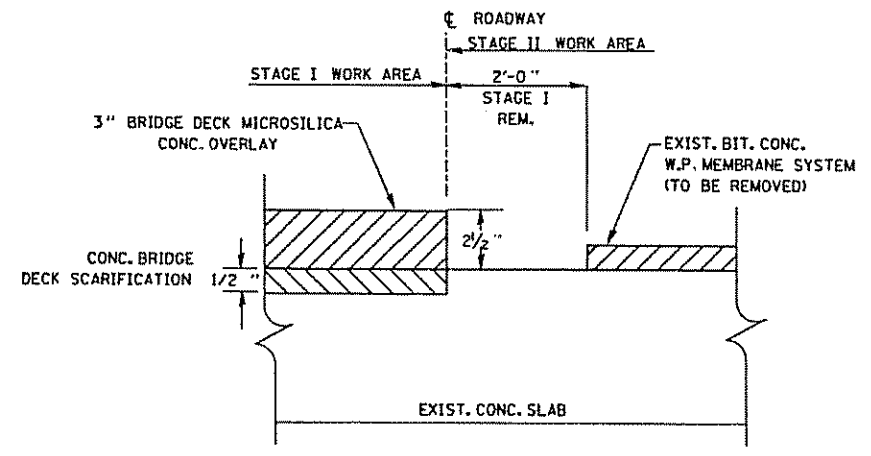

STAGE I
LOOKING SOUTH

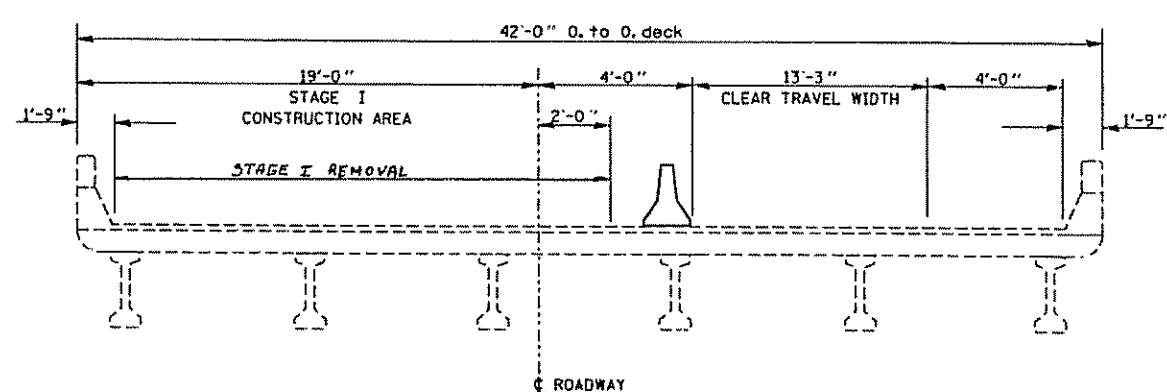

STAGE I
LOOKING NORTH

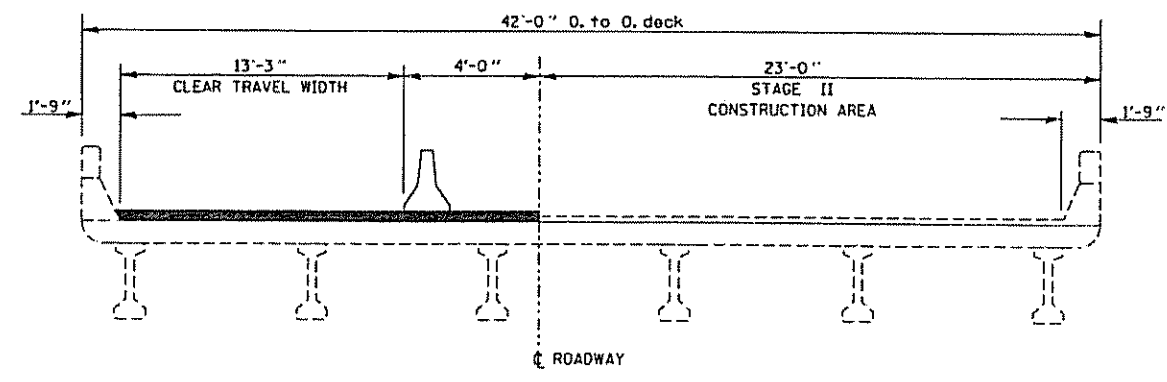

STAGE II

STAGE CONSTRUCTION DIAGRAM
S.N. 057-0167

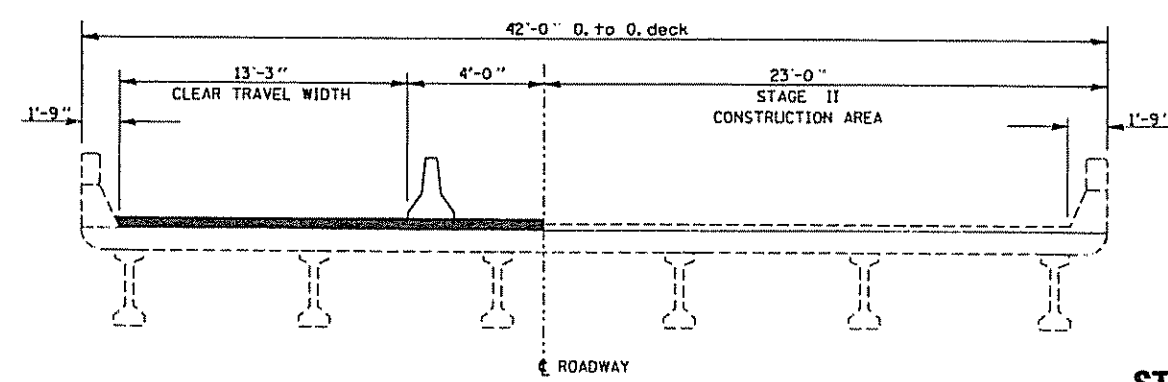

STAGE II

STAGE CONSTRUCTION DIAGRAM
S.N. 057-0168

STAGING DETAILS
F.A.I. 55 S.B. OVER MACKINAW RIVER
SECTION (57-3-1, 57-3, 57-3-2, 57-2) RS
MCLEAN COUNTY
STA. 322 + 95
S.N. 057-0167 & S.N. 057-0168

DEC, 28, 1999
VED021001DETAILS.DGN

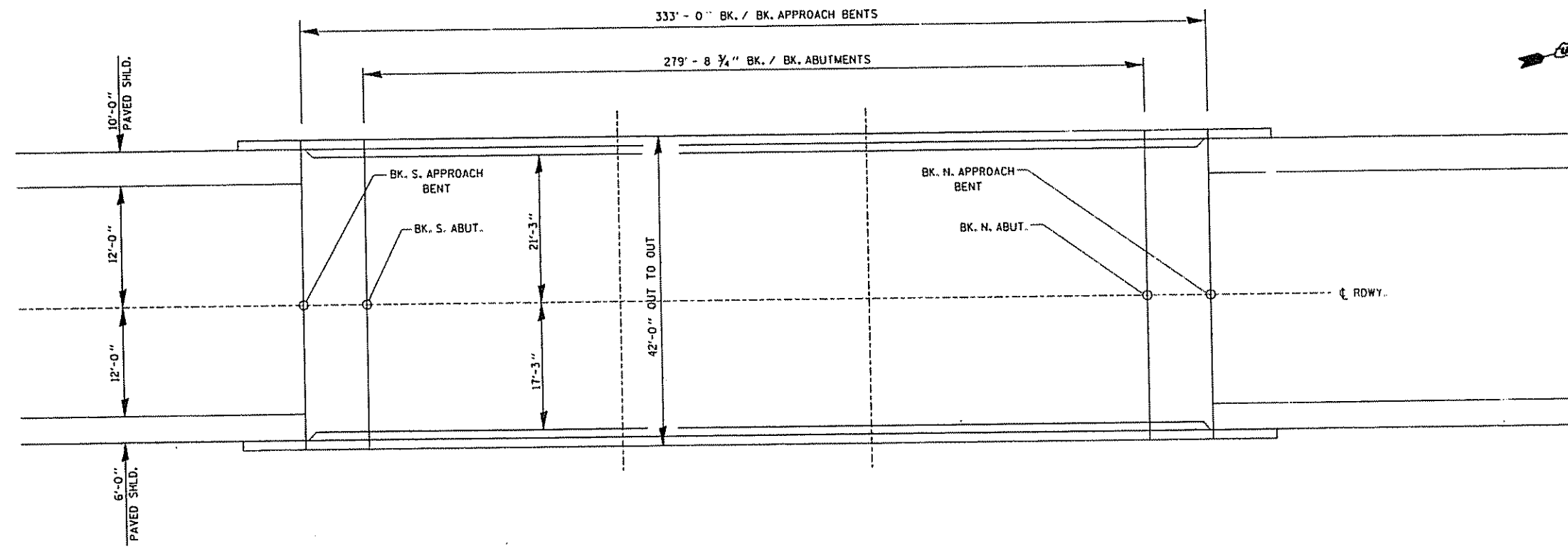

TOTAL BILL OF MATERIALS S.N. 057-0167			
CODE NO.	ITEM	UNIT	QUANT
20300100	CHANNEL EXCAVATION	CU YD	500
28100105	STONE RIPRAP, CLASS A3	SO YD	3
28100107	STONE RIPRAP, CLASS A4	SO YD	112
28200100	FILTER FABRIC FOR USE WITH RIPRAP	SO YD	136
44001000	BITUMINOUS CONCRETE REMOVAL (DECK)	SO YD	1402
50102400	CONCRETE REMOVAL	CU YD	2.4
50104650	SLOPE WALL REMOVAL	SO YD	20
50300130	PREFORMED JOINT SEAL - 4"	FOOT	42
50300155	NEOPRENE EXPANSION JOINT - 2 1/2"	FOOT	41
50300255	CONCRETE SUPERSTRUCTURE	CU YD	2.5
50300260	BRIDGE DECK GROOVING	SO YD	1328
50300300	PROTECTIVE COAT	SO YD	1410
50301245	FORMED CONCRETE REPAIR (DEPTH LESS THAN OR EQUAL TO 5")	SO FT	8
50500405	FURNISHING AND ERECTING STRUCTURAL STEEL	POUND	3805
50800205	REINFORCEMENT BARS, EPOXY COATED	POUND	481
51100300	SLOPE WALL 6 INCH	SO YD	20
59000100	EPOXY CRACK SEALING	FOOT	81
X0321468	PLUG EXISTING DECK DRAINS	EACH	12
X0322194	POLYMER MODIFIED PORTLAND CEMENT MORTAR	SO FT	9
Z0002600	BAR SPLICERS	EACH	8
Z0006110	BRIDGE DECK MICROSILICA CONCRETE OVERLAY	SO YD	1379
Z0012200	CONCRETE BRIDGE DECK SCARIFICATION	SO YD	1379
Z0016001	DECK SLAB REPAIR (FULL DEPTH, TYPE I)	SO YD	1
Z0016200	DECK SLAB REPAIR (PARTIAL)	SO YD	12
* Z0031200	JACKING AND CRIBBING	EACH	14

NOTE:
SEE SHEET 3 OF 18 FOR GENERAL NOTES.

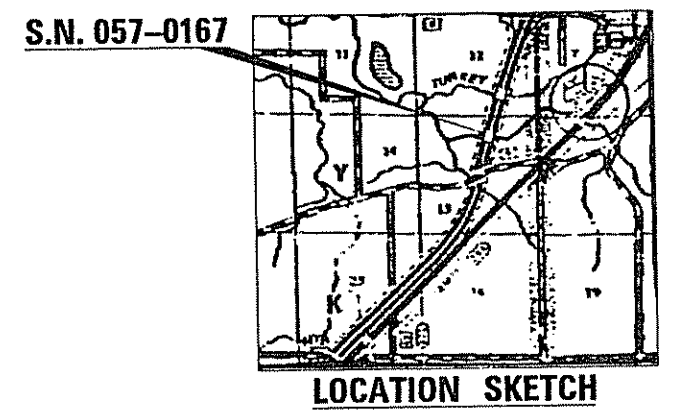

* FOR BEARING REPLACEMENT DETAILS SEE SHEET 15 OF 18.

GENERAL PLAN
F.A.I. 55 S.B. OVER MACKINAW RIVER
SECTION (57-3-1, 57-3, 57-3-2, 57-2) RS
MCLEAN COUNTY
STA. 588 + 37.50
S.N. 057-0167

F.A.I. RTE.	SECTION	COUNTY	TOTAL SHEETS	SHEET NO.
55	◆	MCLEAN	139	92
STA.		TO STA.		
FED. ROAD DIST. NO.	ILLINOIS	FED. AID PROJECT		
◆ (57-3-1, 57-3, 57-3-2, 57-2) RS				

SHEET 3 of 18

General Notes:

1. All structural steel shall conform to AASHTO Classification M-270 Gr. 36 unless otherwise noted.
2. All Structural steel shall be shop painted with Inorganic zinc rich primer per AASHTO M300, Type 1. The cost shall be included in the cost of Furnishing and Erecting Structural Steel.
3. Reinforcement bars shall conform to the requirements of AASHTO M-31, M-42 or M-53 Grade 60.
4. Any reinforcement bars that are damaged during concrete removal shall be replaced with an approved bar splicer or anchorage system. Cost shall be included in the cost of "Concrete Removal".
5. Existing longitudinal reinforcement extending into the removed area shall be cleaned, straightened and incorporated into the new construction. Existing transverse reinforcement may be cut as shown and removed.
6. Joint openings shall be adjusted according to Article 503.10(c) of the Standard Specifications when the deck is poured at an ambient temperature other than 50 degrees Fahrenheit.
7. Plan dimensions and details relative to existing structure have been taken from existing plans and are subject to nominal construction variations. It shall be the Contractor's responsibility to verify such dimensions and details in the field and make necessary approved adjustments prior to construction or ordering of materials. Such variations shall not be cause for additional compensation for a change in the scope of the work, however, the Contractor will be paid for the quantity actually furnished at the unit price bid for the work.

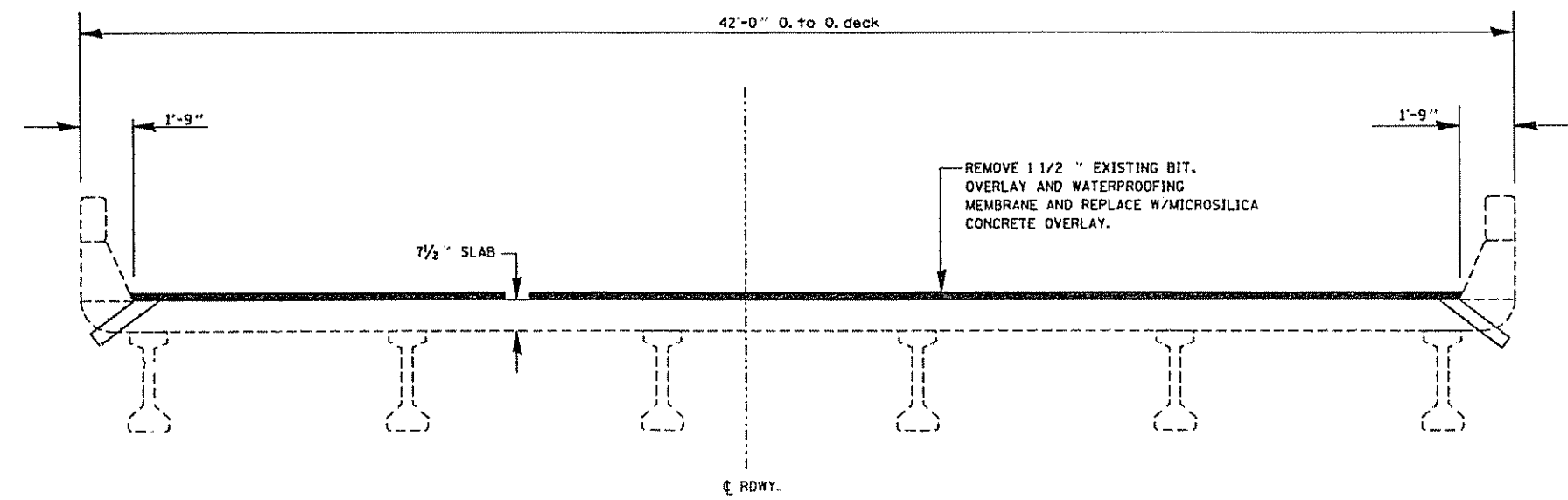

CROSS SECTION
LOOKING SOUTH

GENERAL NOTES AND TYPICAL SECTION
F.A.I. 55 S.B. OVER MACKINAW RIVER
SECTION (57-3-1, 57-3, 57-3-2, 57-2) RS
MCLEAN COUNTY
STA. 588 + 37.50
S.N. 057-0167

DEC. 27, 1999
 VEDDZ/DADETA/LS.DON

F.A.I. RTE.	SECTION	COUNTY	TOTAL SHEETS	SHEET NO.
55	•	MCLEAN	139	93
STA.		TO STA.		
FED. ROAD DIST. NO.		ILLINOIS FED. AID PROJECT		
• 57-3-1, 57-3, 57-3-2, 57-2) RS				

SHEET 4 of 10

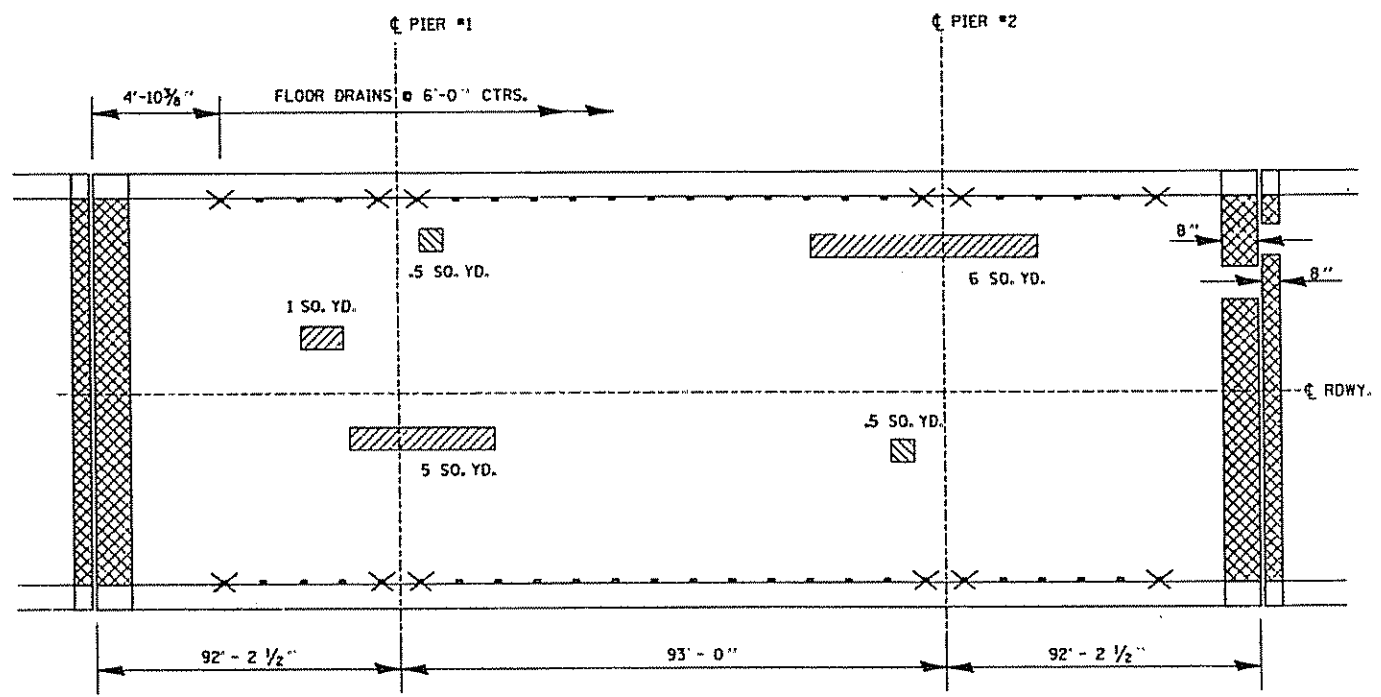

NOTES:

AREA OF DECK REPAIRS SHOWN ARE ESTIMATED. THE ENGINEER SHALL SHOW ACTUAL LOCATIONS OF DECK REPAIRS ON AS-BUILT PLANS.

EXISTING DECK DRAINS LOCATED WITHIN 10 FT. OF A PIER OR AN ABUTMENT SHALL BE ELIMINATED.

	UNIT	STAGE I	STAGE II	TOTAL
CONC. REMOVAL	CU. YD.	.9	1.5	2.4
CONC. SUPERSTRUCTURE	CU. YD.	.9	1.5	2.4
PLUG EXISTING DECK DRAINS	EACH	6	6	12
DECK SLAB REPAIR (PARTIAL DEPTH)	SO. YD.	5	7	12
DECK SLAB REPAIR (FULL DEPTH)	SO. YD.	.5	.5	1

DECK SURVEY DATE: FEBRUARY 9, 1999

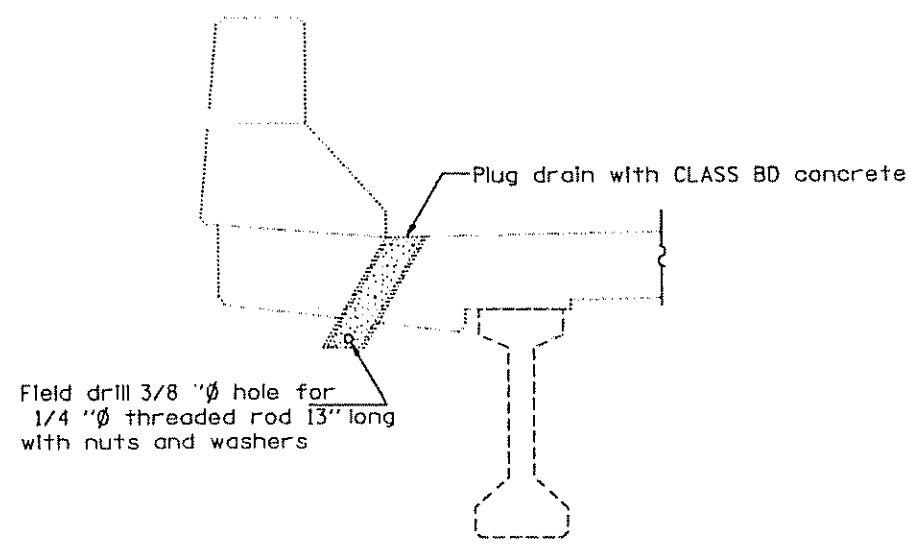

SECTION AT DRAIN
DRAIN ELIMINATION DETAILS

DECK REPAIR PLAN
F.A.I. 55 S.B. OVER MACKINAW RIVER
SECTION (57-3-1, 57-3, 57-3-2, 57-2) RS
MCLEAN COUNTY
STA. 588 + 37.50
S.N. 057-0167

DEC. 22, 1999
VEDD/100/DET/ALS.DGN

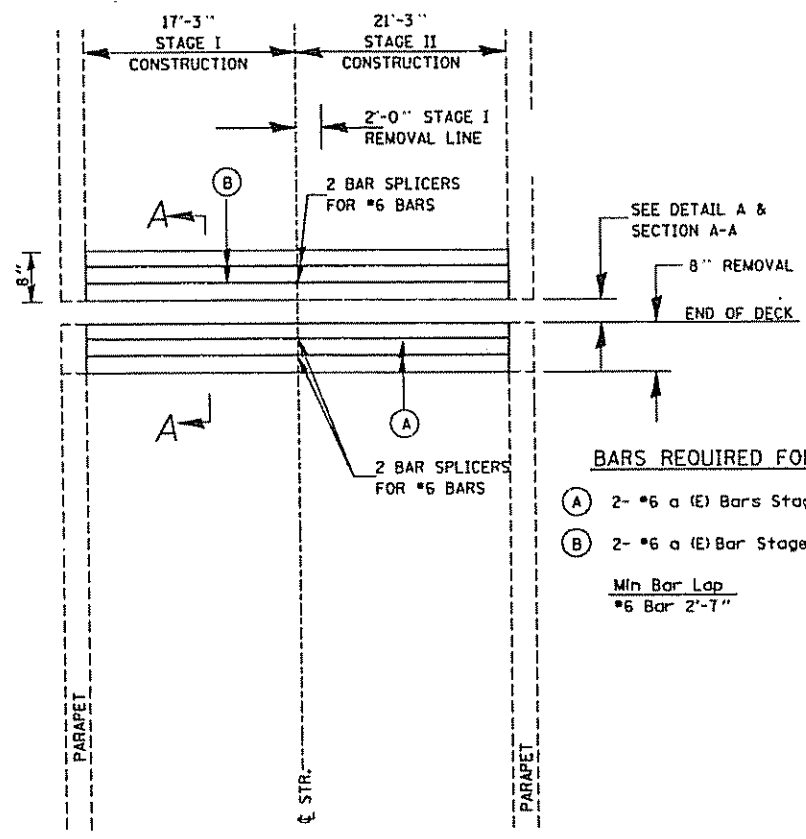

- BARS REQUIRED FOR EACH STAGE**
- (A) 2- #6 a (E) Bars Stage I, (a₂(E) Bars - Stage II)
 - (B) 2- #6 a (E) Bar Stage I, (a₂(E) Bars - Stage II)
- Min Bar Lap
#6 Bar 2'-7"

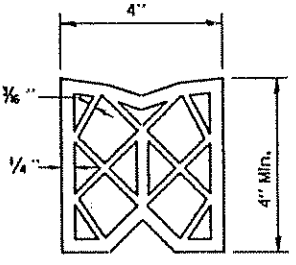
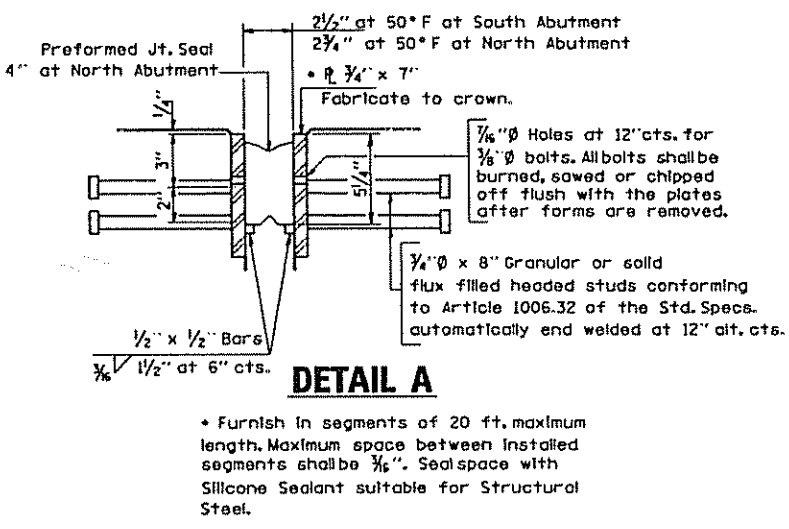

PREFORMED JOINT SEAL (4")
(NORTH ABUTMENT)

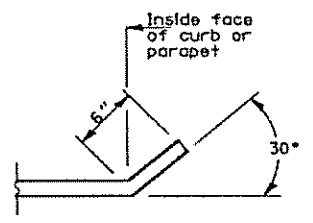

END OF PLATE

NOTES:

1. THE LIMITS OF ALL CONCRETE REMOVAL SHALL BE SAW CUT 3/4" INTO CONCRETE.
2. EXISTING LONGITUDINAL BARS IN DECK AND VERTICAL BARS IN ABUTMENT BACKWALL EXTENDING INTO THE REMOVED AREA SHALL BE CLEANED, STRAIGHTENED, AND INCORPORATED IN THE NEW WORK.
3. EXISTING PARAPET REINFORCEMENT EXTENDING INTO THE REMOVED AREA SHALL BE CLEANED, STRAIGHTENED AND INCORPORATED INTO THE NEW CONSTRUCTION.
4. THE REMOVAL AND REPLACEMENT OF CONCRETE AT THE ABUTMENT BACKWALL AND DECK WILL BE PAID FOR AS CONCRETE REMOVAL AND CONCRETE SUPERSTRUCTURE.
5. THE PARAPET SHALL REMAIN IN PLACE. CONCRETE REMOVAL AT THE ABUTMENT AND DECK SIDE SHALL BE FROM FACE OF PARAPET TO FACE OF PARAPET.
6. THE REMOVAL OF EXISTING PJS, NEOPRENE JOINT SEAL AND STEEL ARMOUR SHALL BE INCLUDED IN THE COST OF "CONCRETE REMOVAL".

PLAN AT SOUTH ABUTMENT
(NORTH ABUTMENT MIRROR IMAGE)

BILL OF MATERIAL		SN 057-0167		
BAR	NO.	SIZE	LENGTH (FT.)	SHAPE
a(E)	8	#6	17'-0"	—
a ₂ (E)	8	#6	21'-0"	—
CONCRETE REMOVAL		CU YD	2.4	
CONC. SUPERSTRUCTURE		CU YD	2.4	
BAR SPLICERS		EACH	8	
FURN. & ERECT STRUCT. STEEL		POUND	1705	
REINFORCEMENT BARS, EPOXY COATED		POUND	457	

REINFORCEMENT BARS DESIGNATED (E) SHALL BE EPOXY COATED

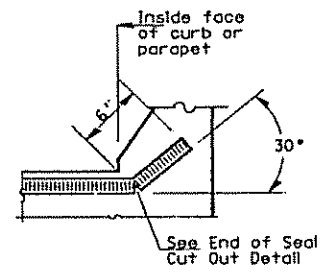
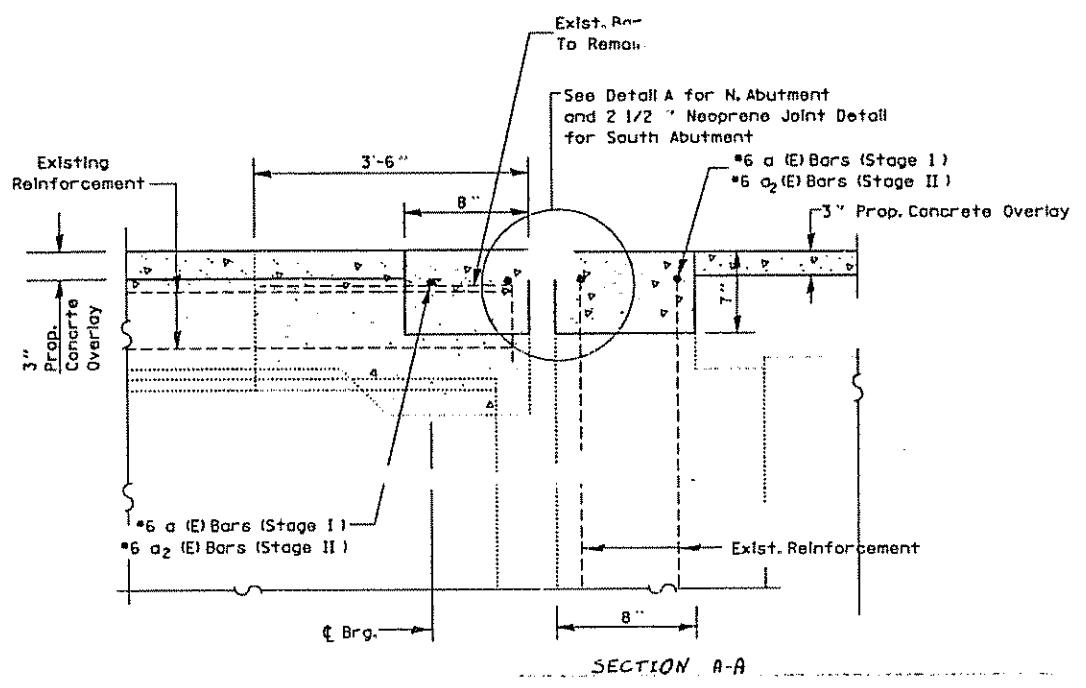

END OF SEAL

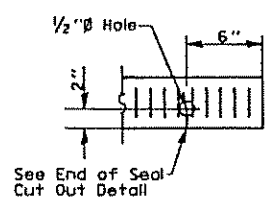

SEAL CUT-OUT 4"

EXPANSION JOINT REPLACEMENT DETAILS
F.A.I. 55 S.B. OVER MACKINAW RIVER
SECTION (57-3-1, 57-3, 57-3-2, 57-2) RS
MCLEAN COUNTY
STA. 588 + 37.50
S.N. 057-0167

F.A.I. RTE.	SECTION	COUNTY	TOTAL SHEETS	SHEET NO.
55	*	MCLEAN	139	95
STA.	TO STA.			
FED. ROAD DIST. NO.	ILLINOIS	FED. AID PROJECT		
* 57-3-1, 57-3, 57-3-2, 57-21 RS				

SHEET 8 of 18

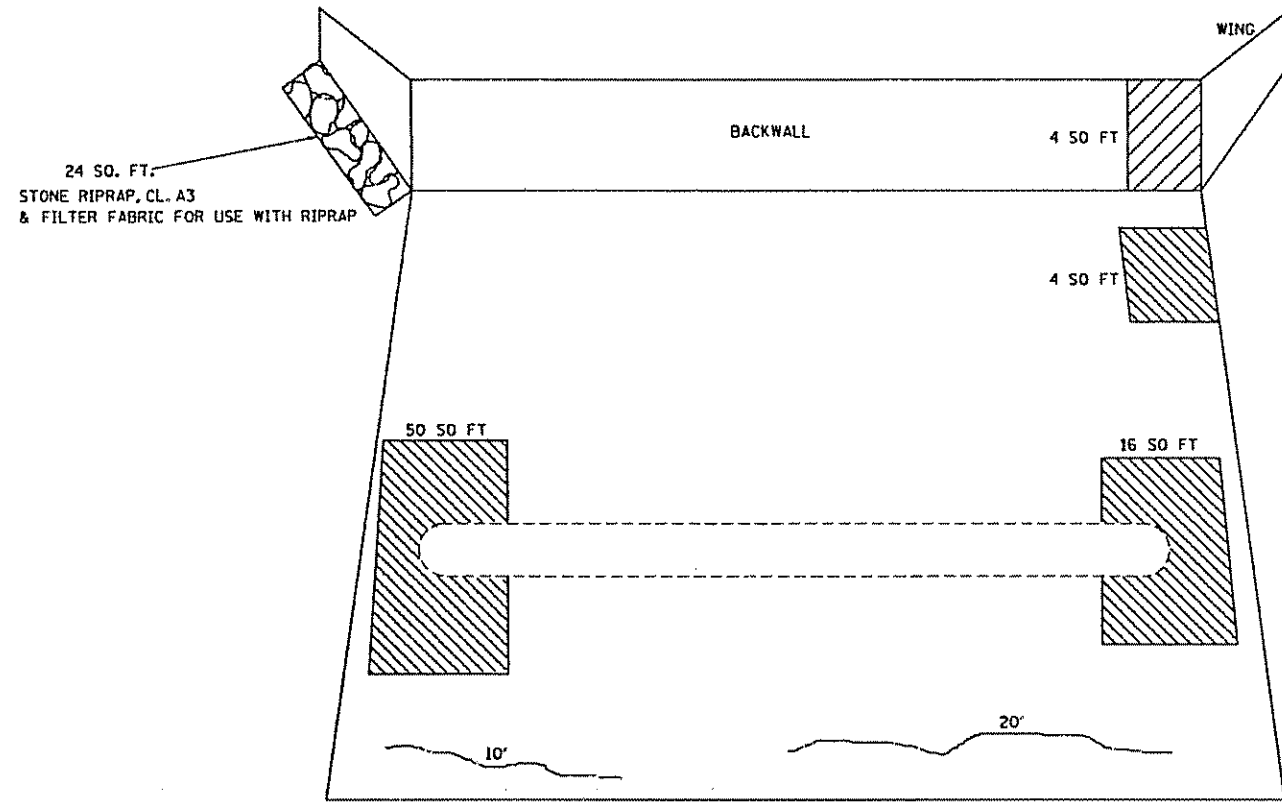



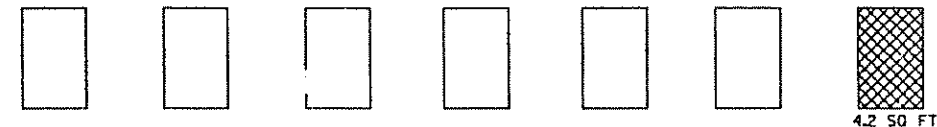



NORTH SLOPEWALL

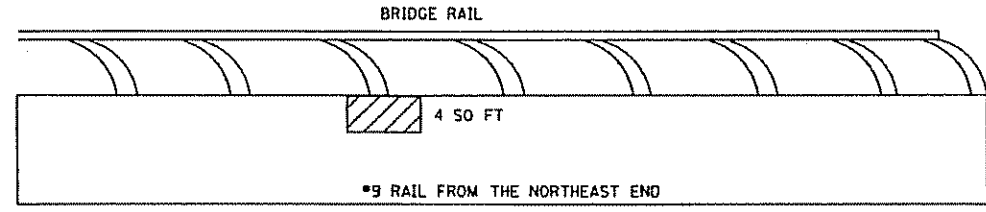

NORTH BEAM ENDS

**SLOPEWALL, BACKWALL & WINGWALL CRACKS and SPALLS
NORTH ABUTMENT**



-  SLOPEWALL REMOVAL = 70 SQ. FT.
-  SLOPEWALL, 6" = 70 SQ. FT.
-  EPOXY CRACK SEALING = 30'
-  POLYMER MODIFIED PORTLAND CEMENT MORTAR = 4.2 SQ. FT.
-  FORMED CONCRETE REPAIR ≤ 5" 8 S.F.
-  RIPRAP = 24 SQ. FT.

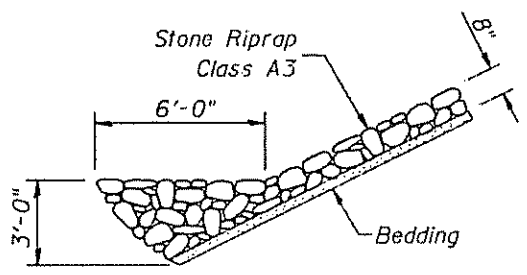

STONE RIPRAP ANCHOR DETAIL

ABUTMENT REPAIRS
F.A.I. 55 S.B. OVER MACKINAW RIVER
SECTION (57-3-1, 57-3, 57-3-2, 57-2) RS
MCLEAN COUNTY
STA. 588 + 37.50
S.N. 057-0167

F.A.I. SHEETS	SECTION	COUNTY	TOTAL SHEETS	SHEET NO.
55	*	MCLEAN	139	90
STA.	TO STA.			
FED. ROAD DIST. NO.	ILLINOIS	FED. AID PROJECT		
* (57-3-1, 57-3, 57-3-2, 57-2) RS				
SHEET 7 of 18				

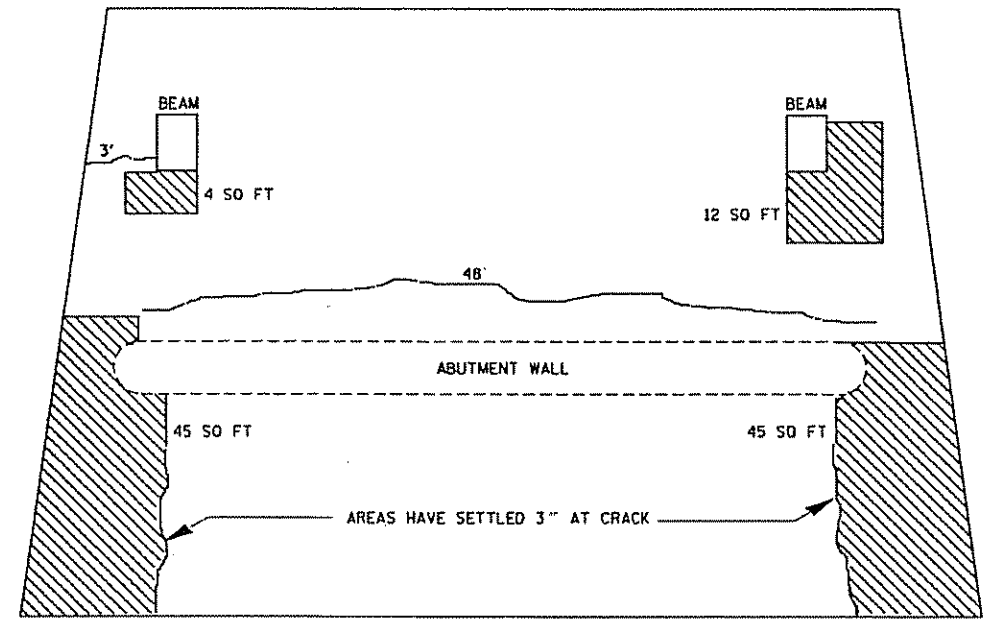

SOUTH SLOPEWALL

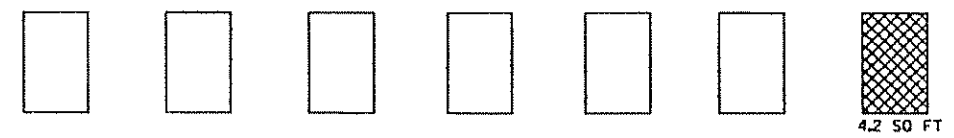

SOUTH BEAM ENDS

- SLOPEWALL REMOVAL = 106 SO. FT.
- SLOPEWALL, 6" = 106 SO. FT.
- EPOXY CRACK SEALING = 51'
- POLYMER MODIFIED PORTLAND CEMENT MORTAR = 4.2 SO. FT.

SLOPEWALL, BACKWALL & WINGWALL CRACKS and SPALLS
SOUTH ABUTMENT

ABUTMENT REPAIRS
F.A.I. 55 S.B. OVER MACKINAW RIVER
SECTION (57-3-1, 57-3, 57-3-2, 57-2) RS
MCLEAN COUNTY
STA. 588 + 37.50
S.N. 057-0167

F.A.I. RTE.	SECTION	COUNTY	TOTAL SHEETS	SHEET NO.
55	*	MCLEAN	139	97
STA.		TO STA.		
FED. ROAD DIST. NO.		ILLINOIS FED. AID PROJECT		
* (57-3-1, 57-3, 57-3-2, 57-2) RS				

SHEET 8 of 18

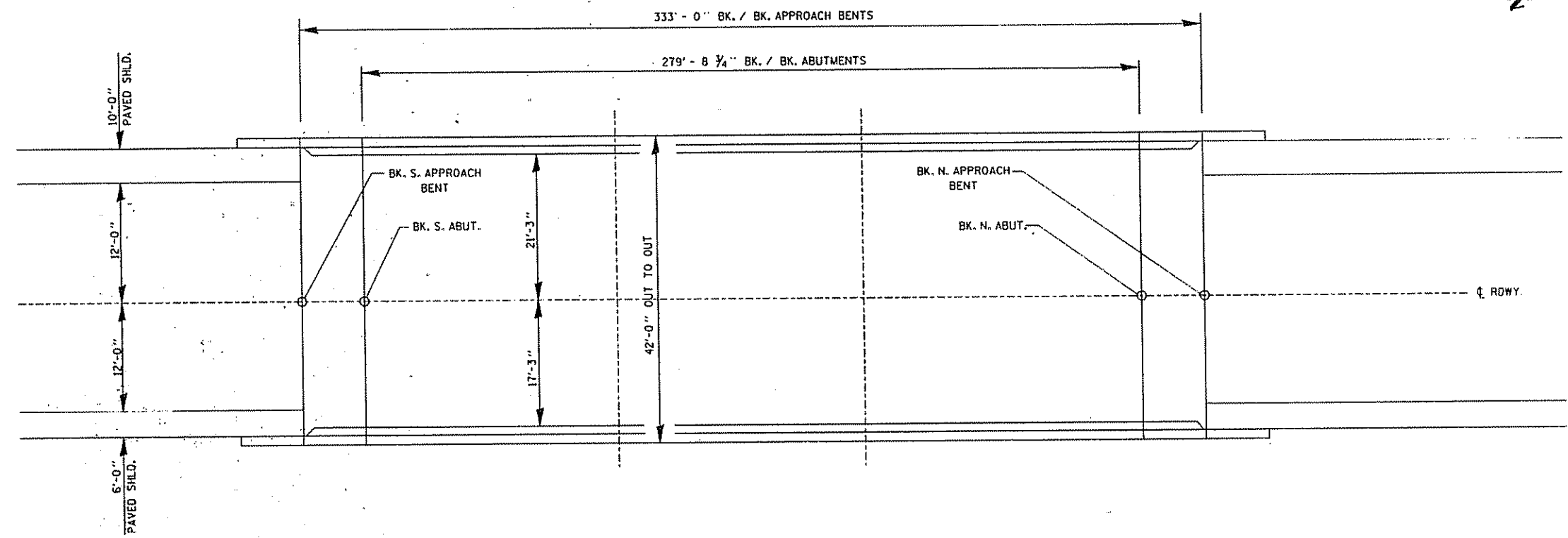

TOTAL BILL OF MATERIALS S.N. 057-0168			
CODE NO.	ITEM	UNIT	QUANT
20300100	CHANNEL EXCAVATION	CU YD	500
28100105	STONE RIPRAP, CLASS A3	SQ YD	5
28100107	STONE RIPRAP, CLASS A4	SQ YD	112
28200100	FILTER FABRIC FOR USE WITH RIPRAP	SQ YD	138
44001000	BITUMINOUS CONCRETE REMOVAL (DECK)	SQ YD	1402
50102400	CONCRETE REMOVAL	CU YD	2.4
50104650	SLOPE WALL REMOVAL	SQ YD	8
50300130	PREFORMED JOINT SEAL - 4"	FOOT	42
50300155	NEOPRENE EXPANSION JOINT - 2 1/2"	FOOT	41
50300255	CONCRETE SUPERSTRUCTURE	CU YD	2.5
50300260	BRIDGE DECK GROOVING	SQ YD	1328
50300300	PROTECTIVE COAT	SQ YD	1410
50301245	FORMED CONCRETE REPAIR (DEPTH LESS THAN OR EQUAL TO 5")	SQ FT	20
50500405	FURNISHING AND ERECTING STRUCTURAL STEEL	POUND	3805
50800205	REINFORCEMENT BARS, EPOXY COATED	POUND	481
51100300	SLOPE WALL 6 INCH	SQ YD	8
59000100	EPOXY CRACK SEALING	FOOT	88
X0321468	PLUG EXISTING DECK DRAINS	EACH	12
X0322194	POLYMER MODIFIED PORTLAND CEMENT MORTAR	SQ FT	13
Z0002600	BAR SPLICERS	EACH	8
Z0006110	BRIDGE DECK MICROSILICA CONCRETE OVERLAY	SQ YD	1379
Z0012200	CONCRETE BRIDGE DECK SCARIFICATION	SQ YD	1379
Z0016001	DECK SLAB REPAIR (FULL DEPTH, TYPE 1)	SQ YD	1
Z0016200	DECK SLAB REPAIR (PARTIAL)	SQ YD	33
Z0031200	JACKING AND CRIBBING	EACH	14

NOTE:
SEE SHEET 9 OF 18 FOR GENERAL NOTES.

S.N. 057-0168

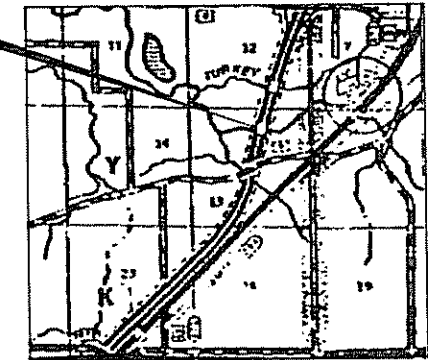

LOCATION SKETCH

* FOR BEARING REPLACEMENT DETAILS SEE SHEET 15 OF 18.

GENERAL PLAN
F.A.I. 55 N.B. OVER MACKINAW RIVER
SECTION (57-3-1, 57-3, 57-3-2, 57-2) RS
MCLEAN COUNTY
STA. 588 + 37.50
S.N. 057-0168

F.A.I. RTE.	SECTION	COUNTY	TOTAL SHEETS	SHEET NO.
55	*	MCLEAN	139	98
STA.	TO STA.			
FED. ROAD DIST. NO.	ILLINOIS	FED. AID PROJECT		
* 57-3-1, 57-3, 57-3-2, 57-21 RS				

SHEET 9 of 18

General Notes:

1. All structural steel shall conform to AASHTO Classification M-270 Gr. 36 unless otherwise noted.
2. All Structural steel shall be shop painted with inorganic zinc rich primer per AASHTO M300, Type 1. The cost shall be included in the cost of Furnishing and Erecting Structural Steel.
3. Reinforcement bars shall conform to the requirements of AASHTO M-31, M-42 or M-53 Grade 60.
4. Any reinforcement bars that are damaged during concrete removal shall be replaced with an approved bar splicer or anchorage system. Cost shall be included in the cost of "Concrete Removal".
5. Existing longitudinal reinforcement extending into the removed area shall be cleaned, straightened and incorporated into the new construction. Existing transverse reinforcement may be cut as shown and removed.
6. Joint openings shall be adjusted according to Article 503.10(c) of the Standard Specifications when the deck is poured at an ambient temperature other than 50 degrees Fahrenheit.
7. Plan dimensions and details relative to existing structure have been taken from existing plans and are subject to nominal construction variations. It shall be the Contractor's responsibility to verify such dimensions and details in the field and make necessary approved adjustments prior to construction or ordering of materials. Such variations shall not be cause for additional compensation for a change in the scope of the work, however, the Contractor will be paid for the quantity actually furnished at the unit price bid for the work.

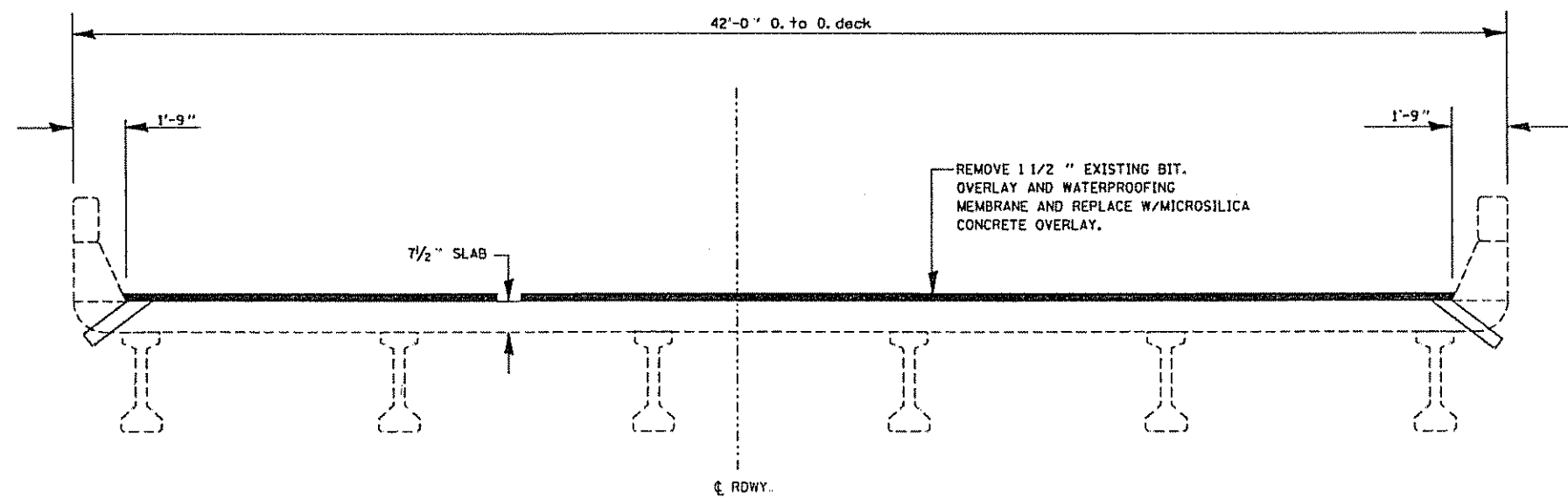

CROSS SECTION
LOOKING NORTH

GENERAL NOTES AND TYPICAL SECTION
F.A.I. 55 S.B. OVER MACKINAW RIVER
SECTION (57-3-1, 57-3, 57-3-2, 57-2) RS
MCLEAN COUNTY
STA. 588 + 37.50
S.N. 057-0168

DEC. 22, 1999
LEDOZ100VDETAILS.DGN

F.A.I. RTE.	SECTION	COUNTY	TOTAL SHEETS	SHEET NO.
55	*	MCLEAN	139	99

STA.	TO STA.
FED. ROAD DIST. NO.	ILLINOIS FED. AID PROJECT
* (57-3-1, 57-3, 57-3-2, 57-2) RS	

SHEET 10 of 18

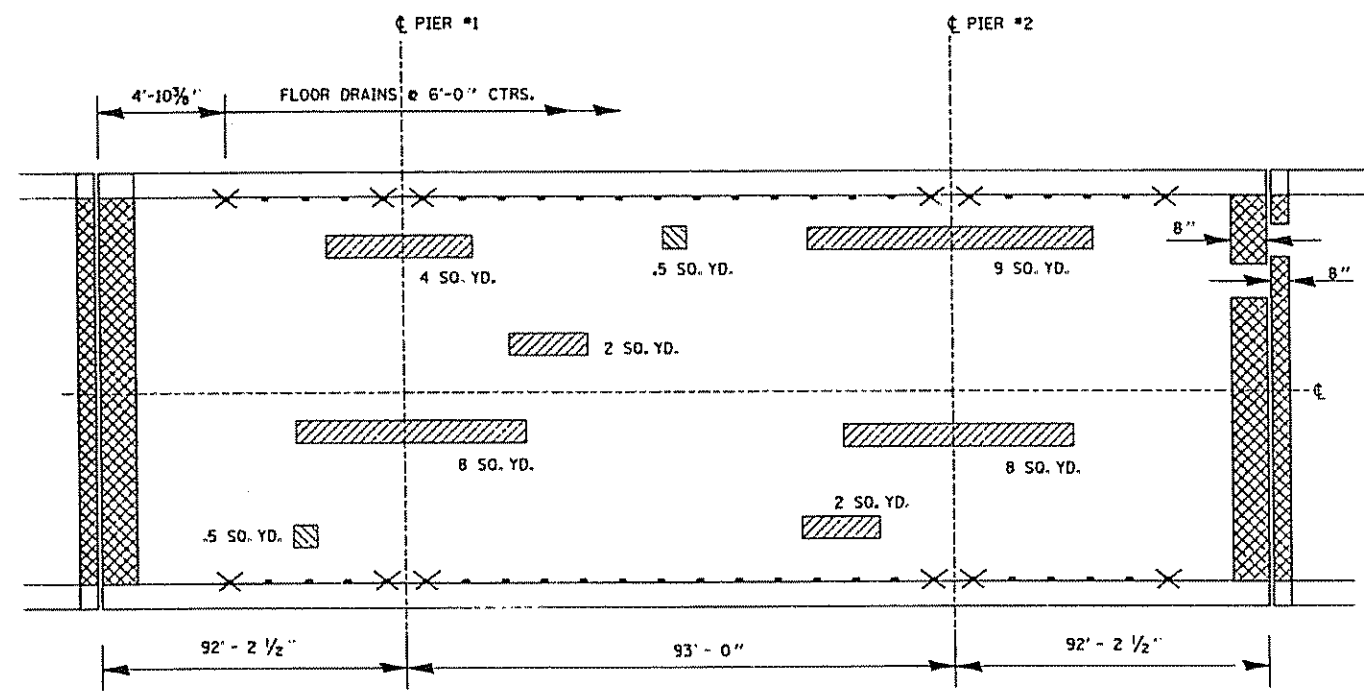

NOTES:

AREA OF DECK REPAIRS SHOWN ARE ESTIMATED. THE ENGINEER SHALL SHOW ACTUAL LOCATIONS OF DECK REPAIRS ON AS-BUILT PLANS.

EXISTING DECK DRAINS LOCATED WITHIN 10 FT. OF A PIER OR AN ABUTMENT SHALL BE ELIMINATED.

	UNIT	STAGE I	STAGE II	TOTAL
CONC. REMOVAL	CU. YD.	.9	1.5	2.4
CONC. SUPERSTRUCTURE	CU. YD.	.9	1.5	2.4
PLUG EXISTING DECK DRAINS	EACH	6	6	12
DECK SLAB REPAIR (PARTIAL DEPTH)	SQ. YD.	15	18	33
DECK SLAB REPAIR (FULL DEPTH)	SQ. YD.	.5	.5	1

DECK SURVEY DATE: FEBRUARY 9, 1999

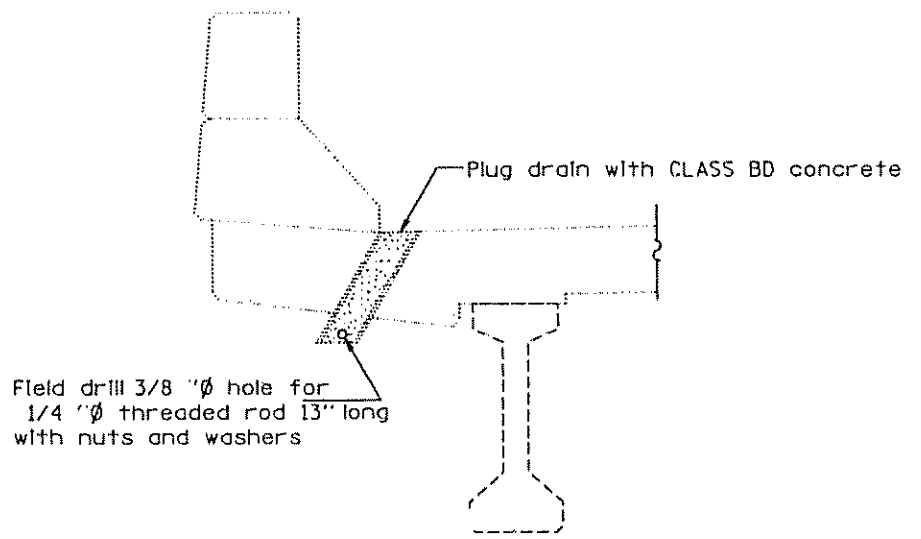

SECTION AT DRAIN
DRAIN ELIMINATION DETAILS

DECK REPAIR PLAN
F.A.I. 55 N.B. OVER MACKINAW RIVER
SECTION (57-3-1, 57-3, 57-3-2, 57-2) RS
MCLEAN COUNTY
STA. 588 + 37.50
S.N. 057-0168

F.A.I. RTE.	SECTION	COUNTY	TOTAL SHEETS	SHEET NO.
55	♦	MCLEAN	139	100
STA.	TO STA.			
FED. ROAD DIST. NO.	ILLINOIS	FED. AID PROJECT		
♦ 57-3-1, 57-3, 57-3-2, 57-2) RS		SHEET 11 of 18		

NOTES:

1. THE LIMITS OF ALL CONCRETE REMOVAL SHALL BE SAW CUT 3/4" INTO CONCRETE.
2. EXISTING LONGITUDINAL BARS IN DECK AND VERTICAL BARS IN ABUTMENT BACKWALL EXTENDING INTO THE REMOVED AREA SHALL BE CLEANED, STRAIGHTENED, AND INCORPORATED IN THE NEW WORK.
3. EXISTING PARAPET REINFORCEMENT EXTENDING INTO THE REMOVED AREA SHALL BE CLEANED, STRAIGHTENED AND INCORPORATED INTO THE NEW CONSTRUCTION.
4. THE REMOVAL AND REPLACEMENT OF CONCRETE AT THE ABUTMENT BACKWALL AND DECK WILL BE PAID FOR AS CONCRETE REMOVAL AND CONCRETE SUPERSTRUCTURE.
5. THE PARAPET SHALL REMAIN IN PLACE. CONCRETE REMOVAL AT THE ABUTMENT AND DECK SIDE SHALL BE FROM FACE OF PARAPET TO FACE OF PARAPET.
6. THE REMOVAL OF EXISTING PJS, NEOPRENE JOINT SEAL AND STEEL ARMOUR SHALL BE INCLUDED IN THE COST OF "CONCRETE REMOVAL".

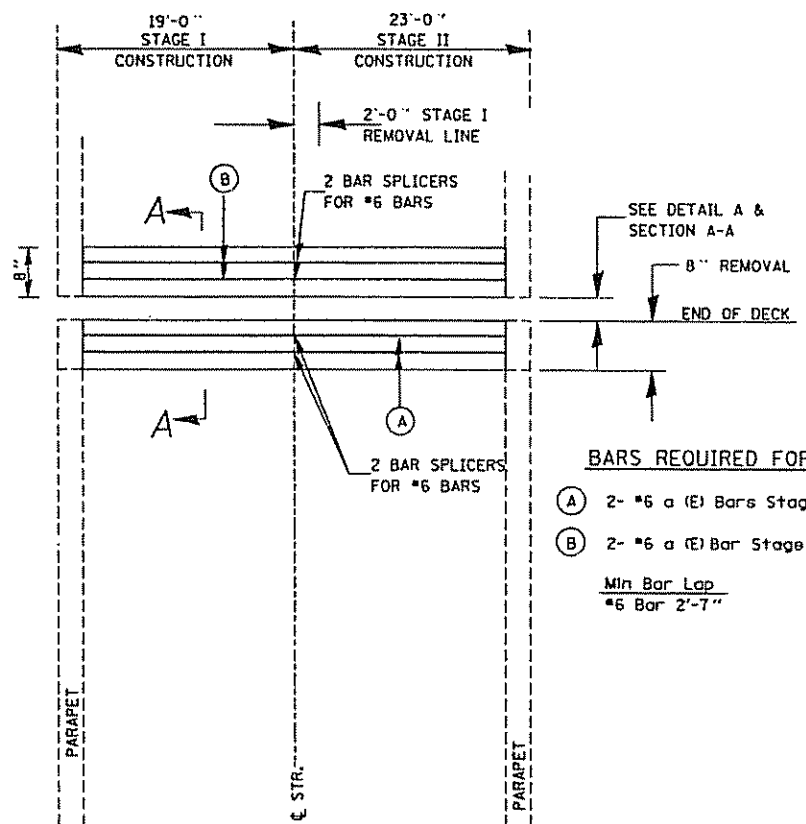

BARS REQUIRED FOR EACH STAGE

- (A) 2- #6 a (E) Bars Stage I, a₂(E) Bars - Stage II
 - (B) 2- #6 a (E) Bar Stage I, a₂(E) Bars - Stage II
- Min Bar Lap
#6 Bar 2'-7"

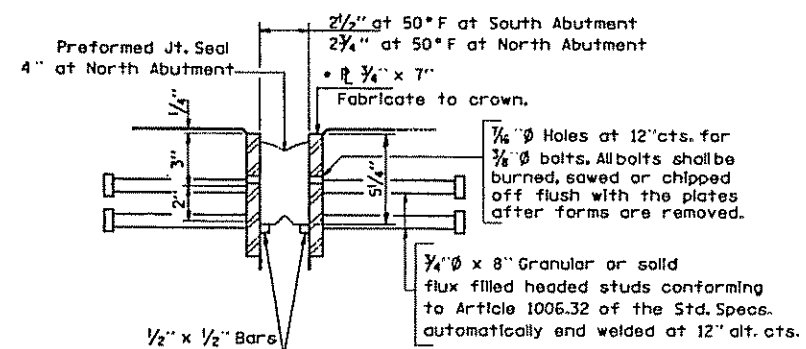

DETAIL A

• Furnish in segments of 20 ft. maximum length. Maximum space between installed segments shall be 3/8". Seal space with Silicone Sealant suitable for Structural Steel.

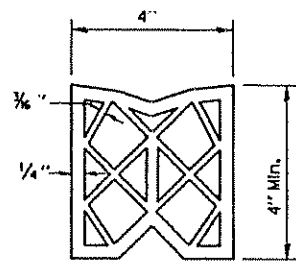

PREFORMED JOINT SEAL (4") (NORTH ABUTMENT)

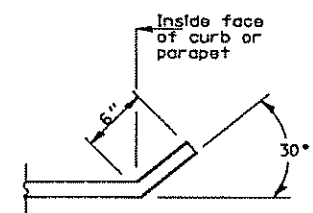

END OF PLATE

PLAN AT NORTH ABUTMENT (SOUTH ABUTMENT MIRROR IMAGE)

BILL OF MATERIAL		SN 057-0168		
BAR	NO.	SIZE	LENGTH (FT.)	SHAPE
a(E)	8	#6	17'-0"	—
a ₂ (E)	8	#6	21'-0"	—
CONCRETE REMOVAL			CU YD	2.4
CONC. SUPERSTRUCTURE			CU YD	2.4
BAR SPLICERS			EACH	8
FURN. & ERECT STRUCT. STEEL			POUND	1705
REINFORCEMENT BARS, EPOXY COATED			POUND	457

REINFORCEMENT BARS DESIGNATED (E) SHALL BE EPOXY COATED

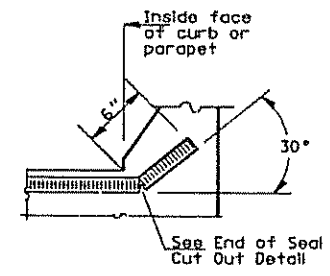
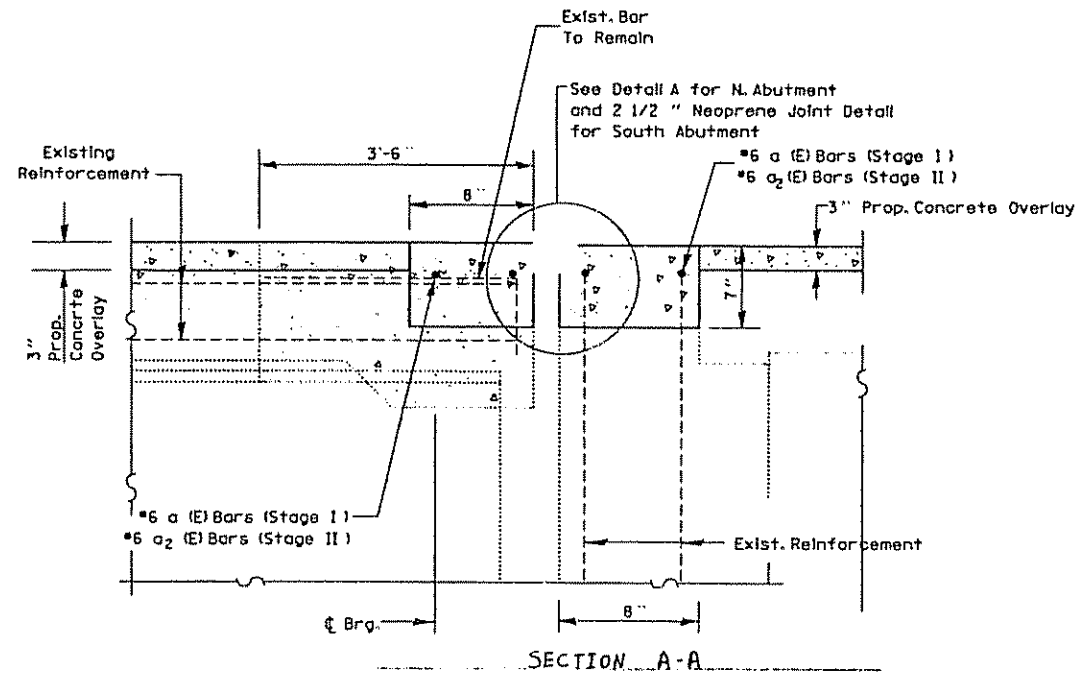

END OF SEAL

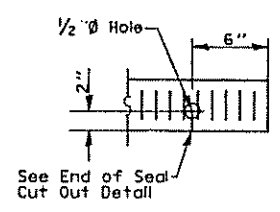

SEAL CUT-OUT 4"



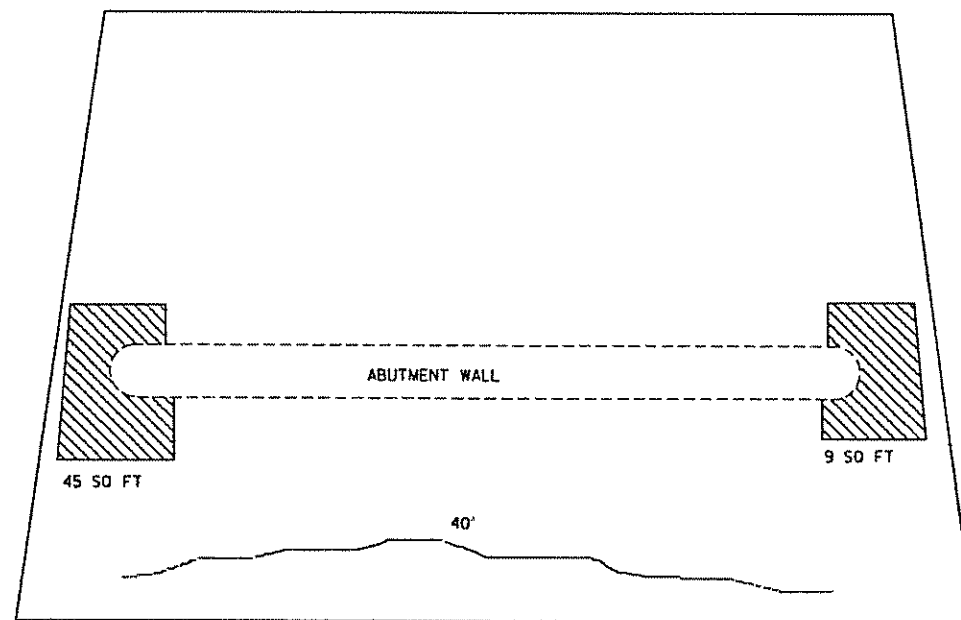

EXPANSION JOINT REPLACEMENT DETAILS
F.A.I. 55 N.B. OVER MACKINAW RIVER
SECTION (57-3-1, 57-3, 57-3-2, 57-2) RS
MCLEAN COUNTY
STA. 588 + 37.50
S.N. 057-0168

F.A.I. RTE.	SECTION	COUNTY	TOTAL SHEETS	SHEET NO.
55	*	MCLEAN	139	101
STA.		TO STA.		
FED. ROAD DIST. NO.		ILLINOIS FED. AID PROJECT		
* 57-3-1, 57-3, 57-3-2, 57-2) RS				

SHEET 12 of 18



NORTH SLOPEWALL

	SLOPEWALL REMOVAL = 54 SQ. FT.
	SLOPEWALL, 6" = 54 SQ. FT.
	EPOXY CRACK SEALING = 40'
	POLYMER MODIFIED PORTLAND CEMENT MORTAR = 4.2 SQ. FT.

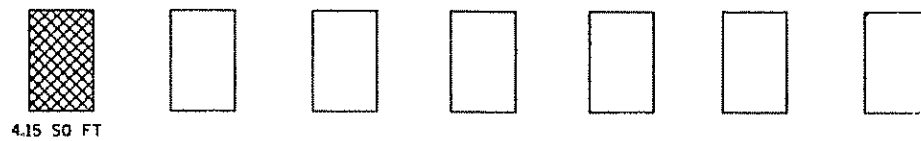

NORTH BEAM ENDS

SLOPEWALL, BACKWALL & WINGWALL CRACKS and SPALLS
NORTH ABUTMENT

ABUTMENT REPAIRS
F.A.I. 55 N.B. OVER MACKINAW RIVER
SECTION (57-3-1, 57-3, 57-3-2, 57-2) RS
MCLEAN COUNTY
STA. 588 + 37.50
S.N. 057-0168

F.A.I. RTE.	SECTION	COUNTY	TOTAL SHEETS	SHEET NO.
55	•	MCLEAN	139	102
STA.	TO STA.			
FED. ROAD DIST. NO.	ILLINOIS	FED. AID PROJECT		
* (57-3-1, 57-3, 57-3-2, 57-2) RS				

SHEET 13 of 18

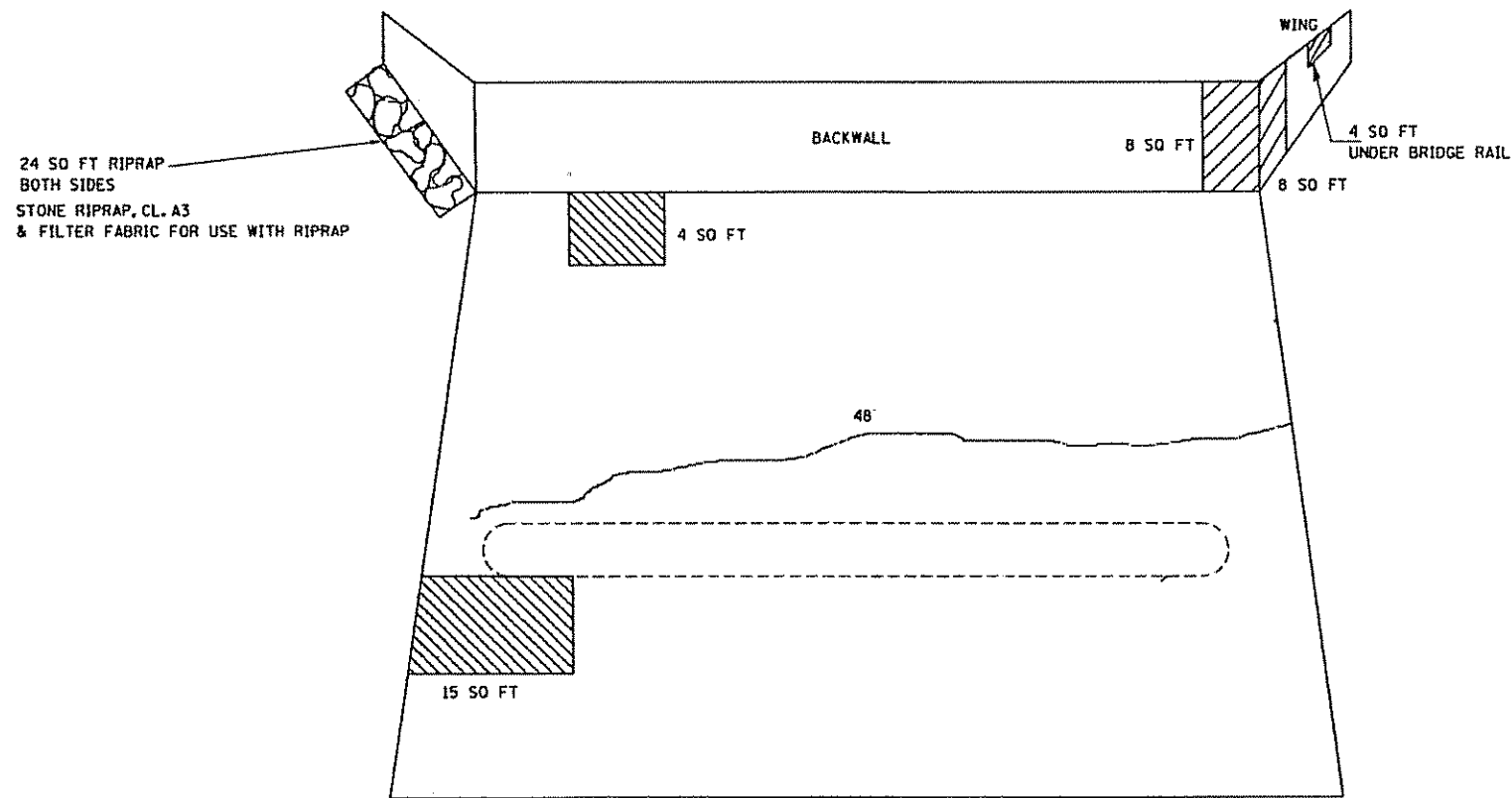

SOUTH SLOPEWALL

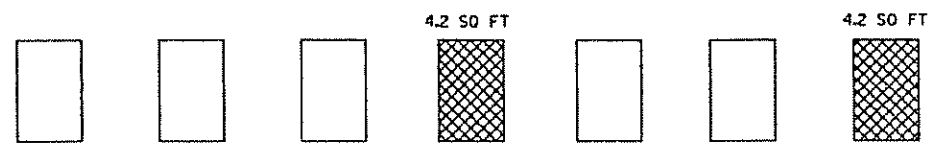

SOUTH BEAM ENDS

**SLOPEWALL, BACKWALL & WINGWALL CRACKS and SPALLS
SOUTH ABUTMENT**

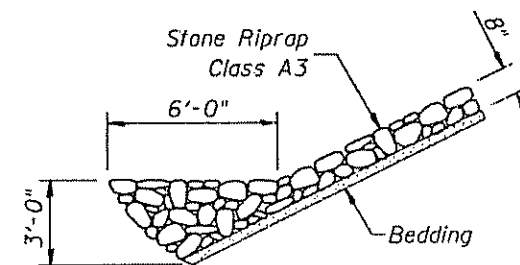
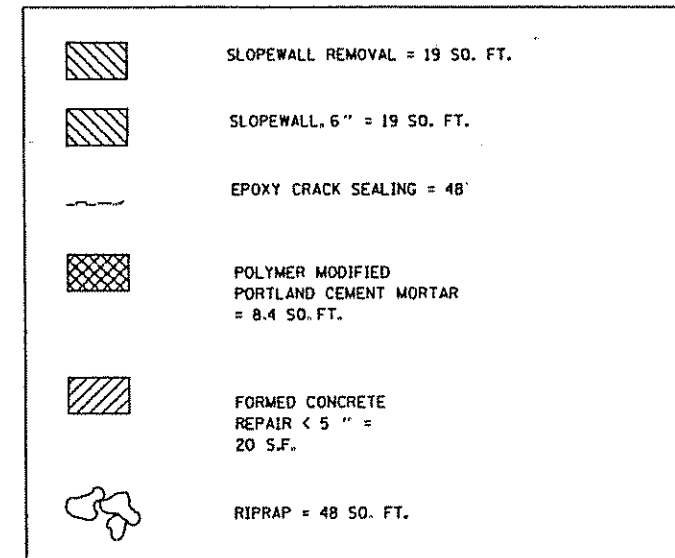

STONE RIPRAP ANCHOR DETAIL

**ABUTMENT REPAIRS
F.A.I. N.B. OVER MACKINAW RIVER
SECTION (57-3-1, 57-3, 57-3-2, 57-2) RS
MCLEAN COUNTY
STA. 588 + 37.50
S.N. 057-0168**

F.A.I. RTE.	SECTION	COUNTY	TOTAL SHEETS	SHEET NO.
55	*	MCLEAN	139	103
STA.		TO STA.		
FED. ROAD DIST. NO.		ILLINOIS	FED. AID PROJECT	
* 57-3-1, 57-3, 57-3-2, 57-21 RS				

SHEET 14 of 18

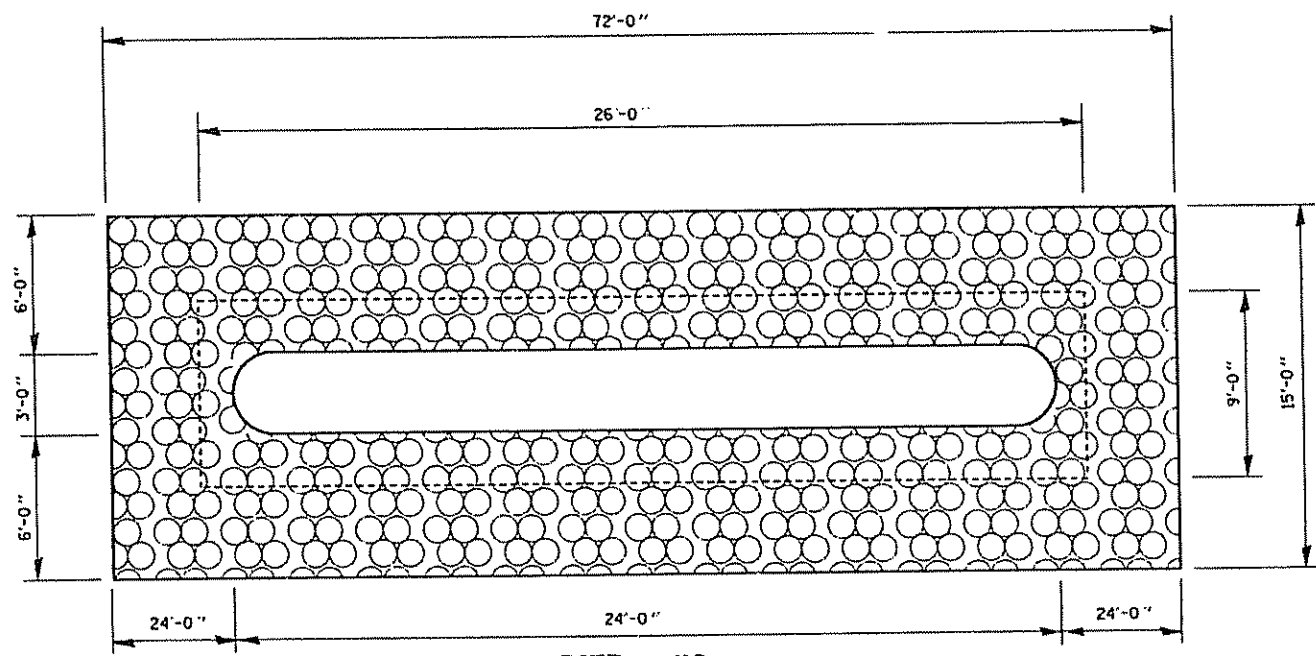

PIER #2

PIER CLOSEST TO CHANNEL

NOTE:
RIPRAP SHALL BE PLACED ONLY AROUND THE PIER CLOSEST TO THE CHANNEL.

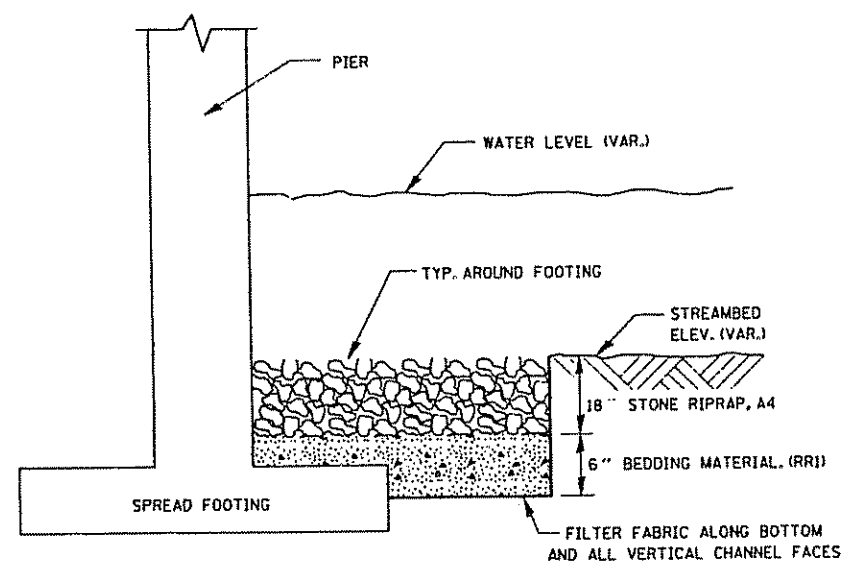

**TYPICAL SECTION FOR PIER.
RIPRAP CLASS A4**

NOTE: CHANNEL EXCAVATION SHALL NOT EXCEED BOTTOM OF FOOTING

STR. # 057-0167 & STR. # 057-0168

**RIPRAP AT PIERS
F.A.I. 55 OVER MACKINAW RIVER
SECTION (57-3-1, 57-3, 57-3-2, 57-2) RS
MCLEAN COUNTY
STA. 588 + 37.50
S.N. 057-0167 & S.N. 057-0168**

F.A.I. RTE.	SECTION	COUNTY	TOTAL SHEETS	SHEET NO.
55	•	MCLEAN	139	104
STA.	TO STA.			
FED. ROAD DIST. NO.	ILLINOIS FED. AID PROJECT			
• (57-3-1, 57-3, 57-3-2, 57-2) RS				

SHEET 15 of 18

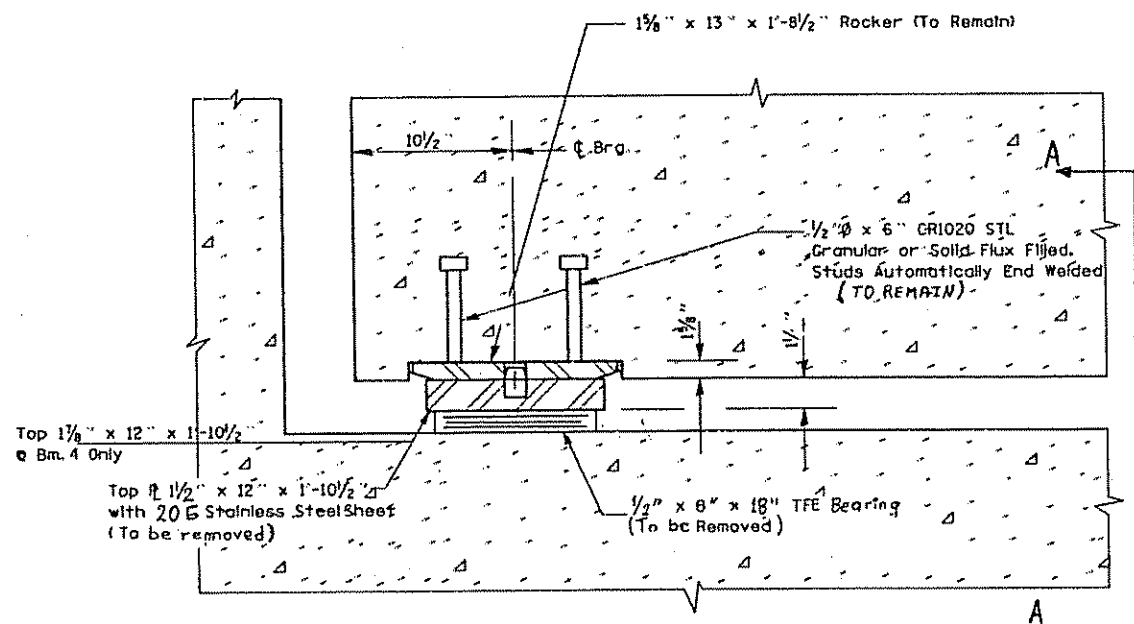

SECTION AT ABUTMENT

BURN EXISTING ANCHOR BOLTS FLUSH WITH EXISTING CONCRETE SURFACE. GRIND EXISTING ANCHOR BOLTS SMOOTH AND SEAL WITH EPOXY.
 COST OF REMOVING EXISTING TFE, SIDE RETAINERS, TOP PLATE, PINTLES AND ANCHOR BOLTS IS INCLUDED WITH JACKING AND CRIBBING.
 COST OF NEW PLATES, PINTLES, ANCHOR BOLTS AND SIDE RETAINERS IS INCLUDED WITH FURNISHING AND ERECTING STRUCTURAL STEEL.

REACTIONS: Dead load (K) = 67.5
 Live Load (K) = 35.3
 Impact (K) = 8.1
 TOTAL (K) = 110.9
 Min. Jack Size = 60 TONS.

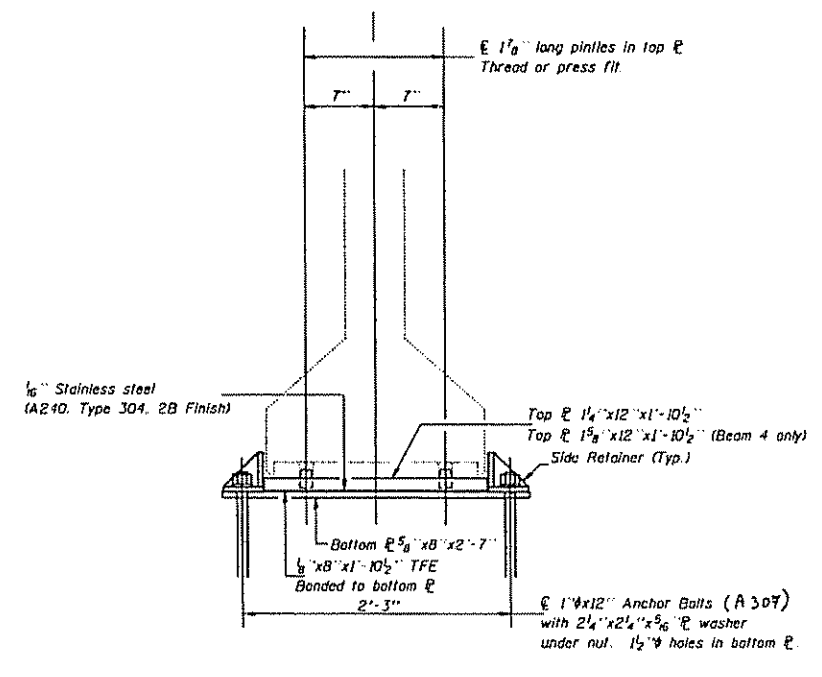

SECTION A-A

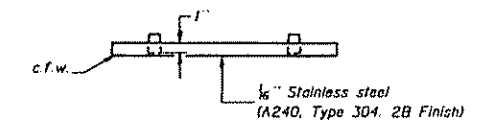

TOP PLATE

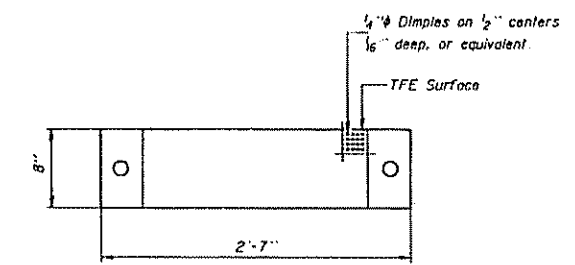

BOTTOM PLATE

Note: The 1/8" TFE sheet shall be bonded directly to the bottom steel plate with a two-component, medium viscosity epoxy resin, conforming to the requirements of the Federal Specification MMM-A-134, Type I. The bond agent shall be applied on the full area of the contact surfaces.
 Bonding of 1/8" TFE sheet during vulcanizing process will be permitted provided the process and method of adjusting assembly height is approved by the Engineer.

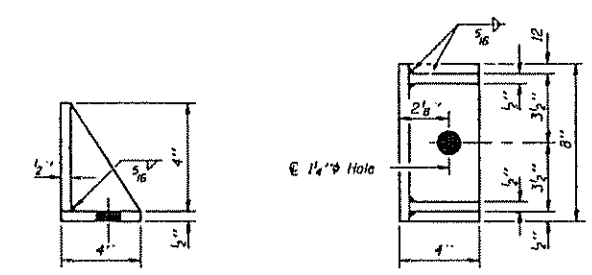

SIDE RETAINER

Equivalent rolled angle with stiffeners will be allowed in lieu of welded plates.

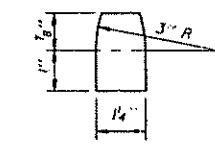

PINTLE

BEARING DETAILS
F.A.I. 55 OVER MACKINAW RIVER
SECTION (57-3-1, 57-3, 57-3-2, 57-2) RS
MCLEAN COUNTY
STA. 588 + 37.50
S.N. 057-0167 & S.N. 057-0168

DEC. 22, 1989
 \ED02100VETA ILS.DGN

F.A.I. R.T.E.	SECTION	COUNTY	TOTAL SHEETS	SHEET NO.
55	*	MCLEAN	139	105
STA.	TO STA.			
FED. ROAD DIST. NO.	ILLINOIS FED. AID PROJECT			
* 57-3-1, 57-3, 57-3-2, 57-2) RS				
SHEET 16 of 18				

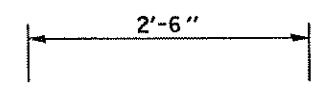
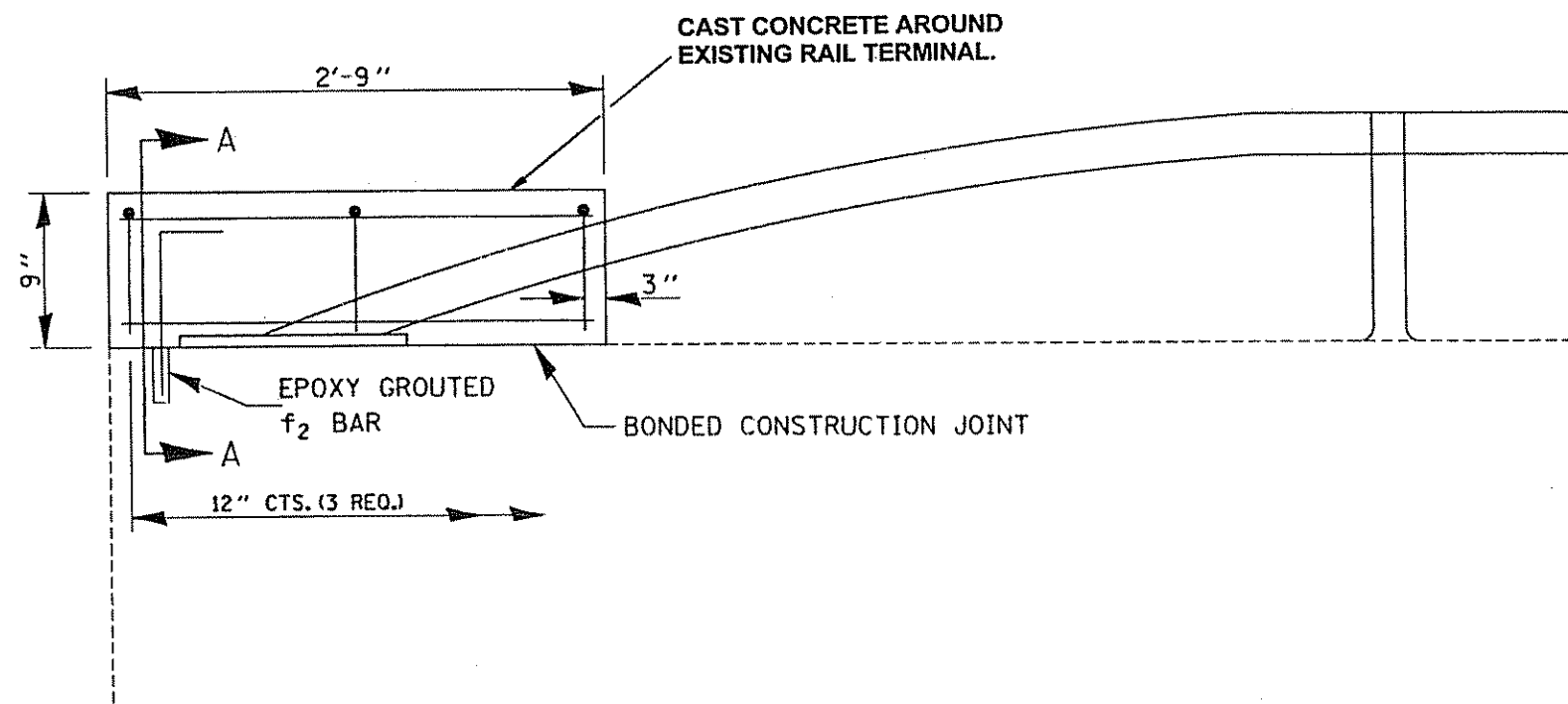

BAR f₃(E)

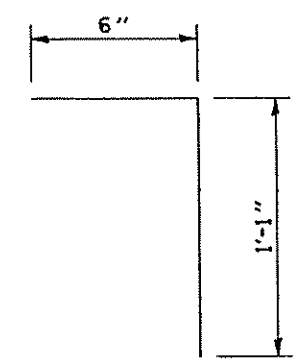

BAR f₂(E)

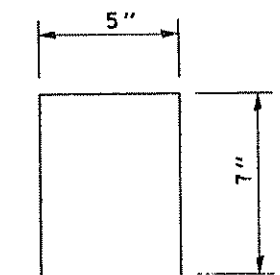

BAR f₁(E)

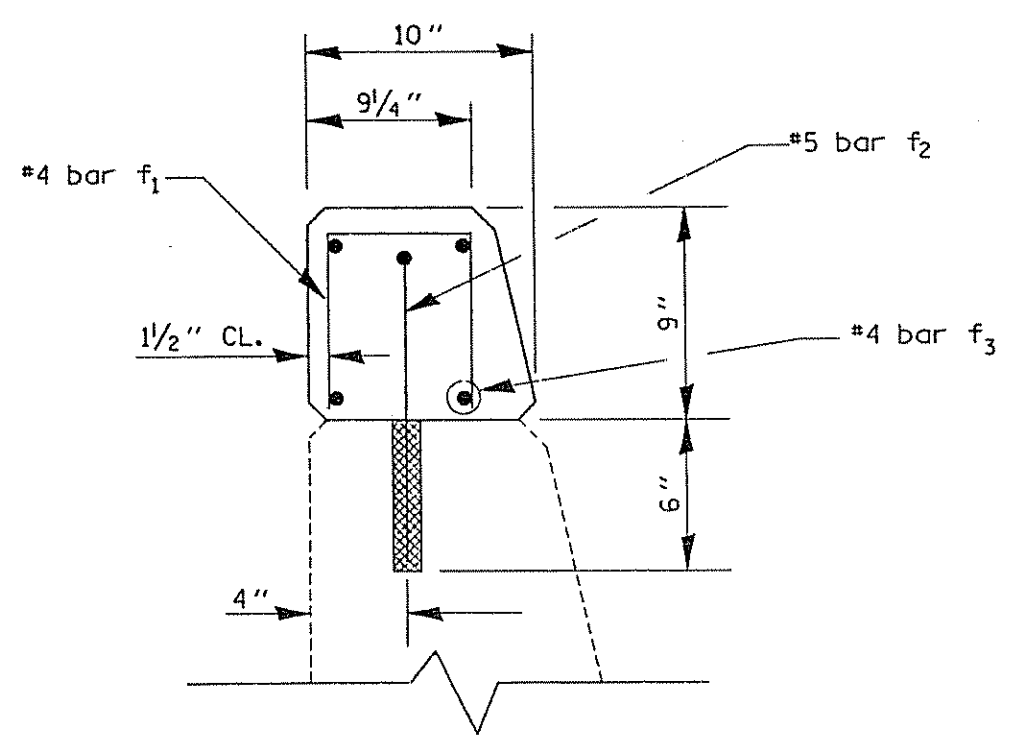

SECTION A-A

BILL OF MATERIAL PARAPET				
BAR	NO.	SIZE	LENGTH (FT.)	SHAPE
f1(E)	3	#4	1' - 7"	□
f2(E)	1	#5	1' - 7"	└
f3(E)	4	#4	2' - 6"	—
CONC. SUPERSTRUCTURE			CU YD	0.06
REINFORCEMENT BARS, EPOXY COATED			POUND	12

REINFORCEMENT BARS DESIGNATED (E) SHALL BE EPOXY COATED

NOTE: QUANTITIES SHOWN ARE FOR EACH PARAPET EXTENSION

PARAPET DETAILS
F.A.I. 55 OVER MACKINAW RIVER
SECTION (57-3-1, 57-3, 57-3-2, 57-2) RS
MCLEAN COUNTY
STA. 588 + 37.50
S.N. 057-0167 - NORTH END
S.N. 057-0168 - SOUTH END

DEC. 29, 1999
 \E0021\CONCRETE\15.DGN

STATE OF ILLINOIS
DEPARTMENT OF TRANSPORTATION

PROJECT NO.	SECTION	CONTRACT	SHEET NO.	TOTAL SHEETS
		MCLEAN	139	106
FED. ROAD DIST. NO. 1				
ILLINOIS				
FED. AID PROJECT				

SHEET NO. 17
18 SHEETS

NOTES

Bar splicer assemblies shall be of an approved type and shall develop in tension at least 125 percent of the yield strength of the lapped reinforcement bars.
Splicer rods shall be of minimum 60 ksi yield strength, threaded or coiled full length.
All reinforcement bars shall be lapped and tied to the splicer rods or dowel bars.
Bar splicer assemblies shall be epoxy coated according to the requirements for reinforcement bars.

Other systems of similar design may be submitted to the Engineer for approval. Approval shall be based on certified test results from an approved testing laboratory that the proposed bar splicer assembly satisfies the following requirements:

- ① Minimum Capacity = $1.25 \times f_y \times A_t$
(Tension in kips)
- ② Minimum Pull-out Strength = $1.25 \times f_{s_{allow}} \times A_t$
(Tension in kips)

Where f_y = Yield strength of lapped reinforcement bars in ksi.

$f_{s_{allow}}$ = Allowable tensile stress in lapped reinforcement bars in ksi (Service Load)

A_t = Tensile stress area of lapped reinforcement bars.

* = 28 day concrete

BAR SPLICER ASSEMBLIES			
Bar Size to be Spliced	Splicer Rod or Dowel Bar Length	Strength Requirements	
		Min. Capacity kips - tension	Min. Pull-Out Strength kips - tension
#5	2'-0"	23.0	9.2
#6	2'-7"	33.1	13.3
#7	3'-5"	45.1	18.0
#8	4'-6"	58.9	23.6

Bar splicer assemblies shall be according to Section 50B of the Standard Specifications, except as noted. The furnishing and installation of bar splicer assemblies will be measured and paid for at the contract unit price each for "BAR SPLICERS."

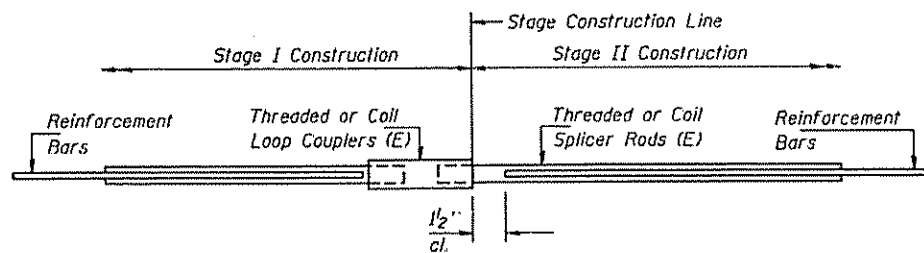

SPLICER DETAIL

Bar Size	No. Assemblies Required	Location
#6	8	SN 057-0167 Stage Const. Line
#6	8	SN 057-0168 Stage Const. Line
Total	16	

The diameter of this part is the same as the diameter of the bar spliced.

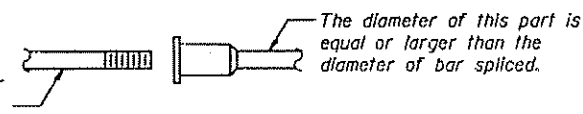

ROLLED THREAD DOWEL BAR



ONE PIECE

Wire Connector



WELDED SECTIONS

BAR SPLICER ASSEMBLY ALTERNATIVES

** Heavy Hex Nuts conforming to ASTM A 563, Grade C, D or DH may be used.

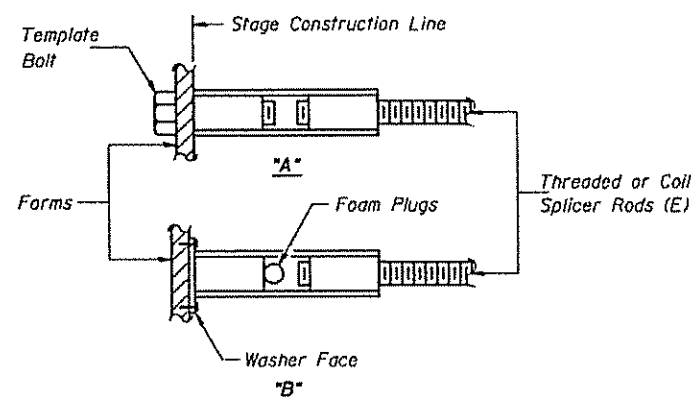

INSTALLATION AND SETTING METHODS

"A" : Set bar splicer assembly by means of a template bolt.

"B" : Set bar splicer assembly by nailing to wood forms or cementing to steel forms.

(E) : Indicates epoxy coating.

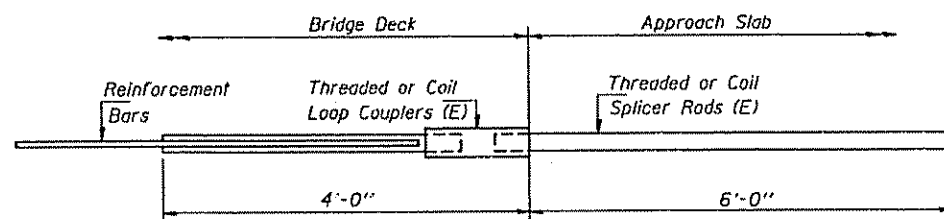

INTEGRAL ABUTMENT
BAR SPLICER ASSEMBLY DETAIL
FOR #5 BAR

Min. Capacity = 23.0 kips - tension
Min. Pull-out Strength = 9.2 kips - tension
No. Required =

DESIGNED	28
CHECKED	EXAMINED
DRAWN	ENGINEER OF BRIDGE DESIGN
CHECKED	PASSED
	ENGINEER OF BRIDGES AND STRUCTURES

BSD-1 4-30-99

BAR SPLICER ASSEMBLY DETAILS
F.A.I. 55 OVER MACKINAW RIVER
SECTION (57-3-1,57-3,57-3-2,57-2) RS
MCLEAN COUNTY
STA. 588 + 37.50
S.N. 057-0167 & S.N. 057-0168

Joint Size	"C" at 50°F	"D" at 50°F
2"	2"	1 1/2" Min.
2 1/2"	2 1/2"	1 3/4" Min.
4"	3"	2 1/2" Min.

INSTALLATION NOTES

- Install continuous seal in roadway, parapet, curb, and sidewalk.
- Install anchor blocks as indicated.

NOTE A: Maximum spacing of anchor bolts shall be 12" centers.

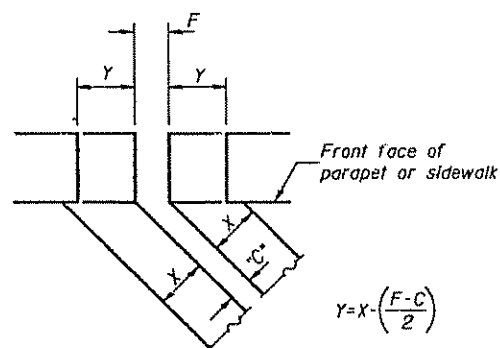

$$Y = X \left(\frac{F - C}{2} \right)$$

For dimension "F" see sheet #

FORMING BLOCKOUT SKETCH

SKREW LIMITATIONS

The details of the anchor blocks and the elastomeric membrane in the parapet, as shown, are for up to 50° skews. For skews greater than 50°, the anchor blocks and the elastomeric membrane, installed according to dimension "D", might require modifications to insure a minimum clearance of 1/2" from centerline of anchor studs to edge of parapet opening. The anchor blocks and the elastomeric membrane shall also be installed to the top of the parapet with the anchor studs spaced at ±12" cts.

STATE OF ILLINOIS DEPARTMENT OF TRANSPORTATION

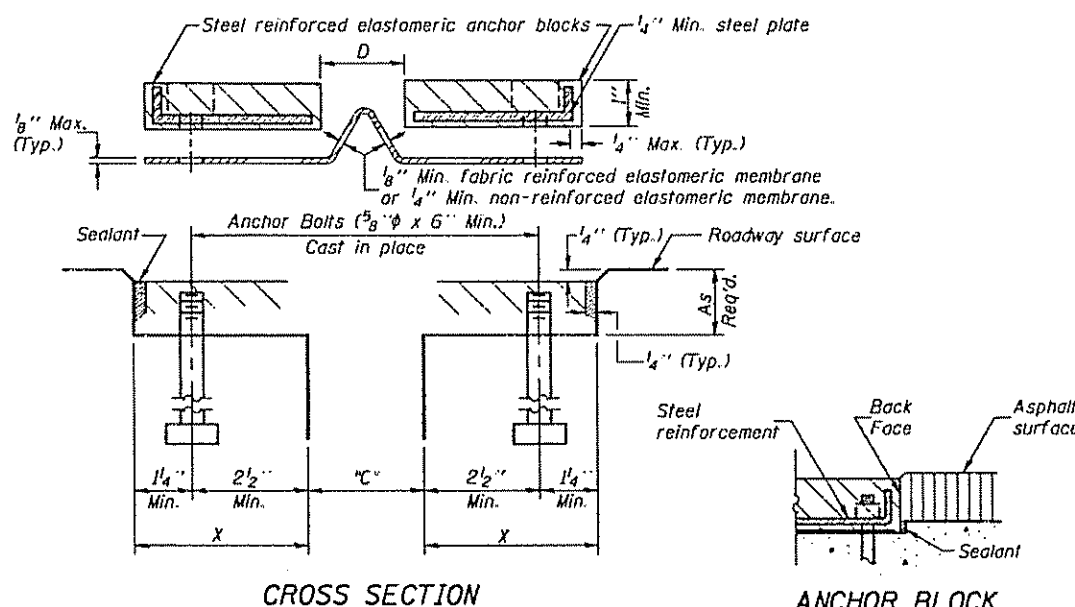

CROSS SECTION

ANCHOR BLOCK WITH ASPHALT SURFACE

GENERAL NOTES

Continuous Seal Neoprene Expansion Joint shall consist of molded anchor blocks of elastomer and steel, field assembled over continuous lengths of elastomeric membrane.

The elastomeric membrane shall be premolded with a single or a double upward convolution that will have a "memory" to return to its molded position upon joint closure.

The convolution length shall be such that the extended length will not be greater than the manufactured length when the joint is fully expanded in its design range and will not protrude above the anchor blocks when the joint is fully compressed.

Joint openings shall be adjusted according to Article 503.10(c) of the Standard Specifications when the deck is poured at an ambient temperature other than 50° F.

The parapet and roadway membrane shall be made continuous by an approved vulcanizing process. Lapping will not be permitted.

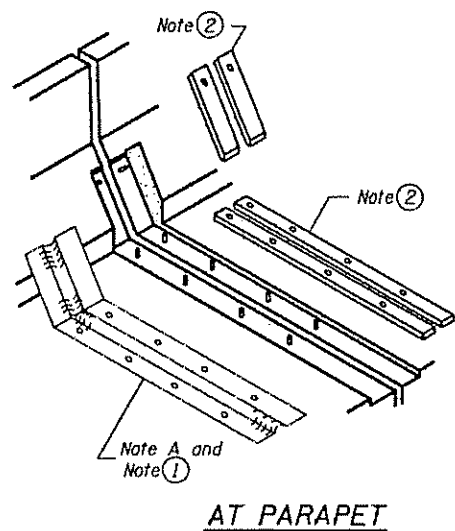

AT PARAPET

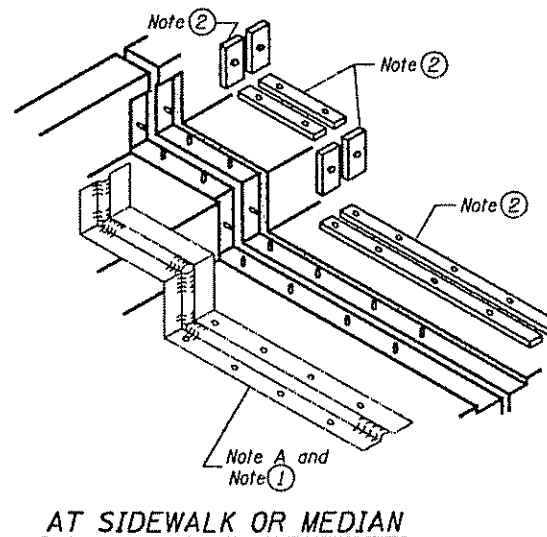

AT SIDEWALK OR MEDIAN

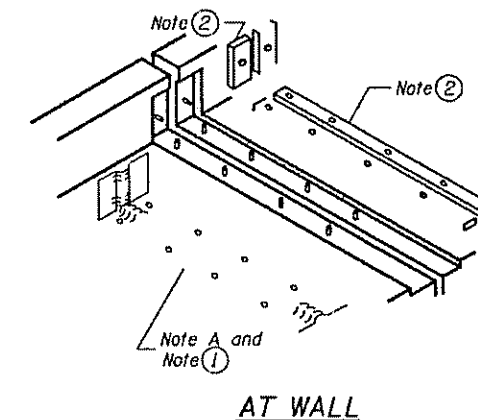

AT WALL

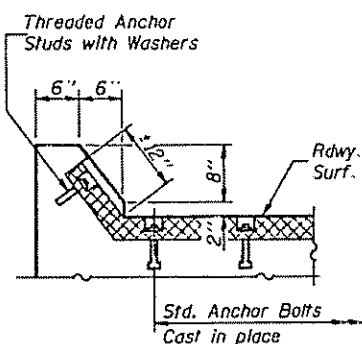

AT CURB

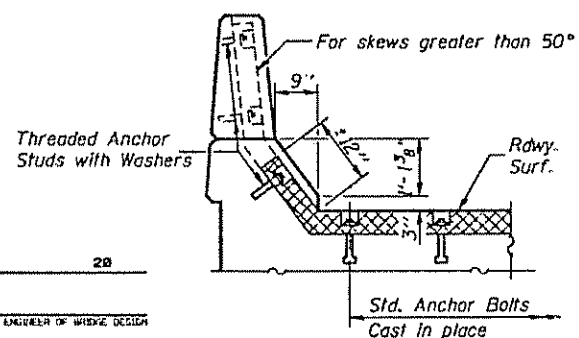

AT PARAPET

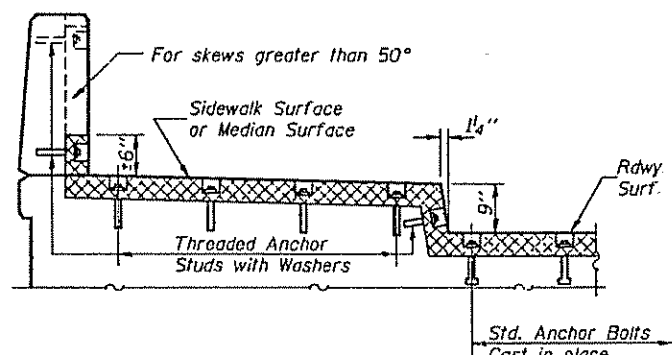

AT SIDEWALK OR MEDIAN
TYPICAL END TREATMENTS

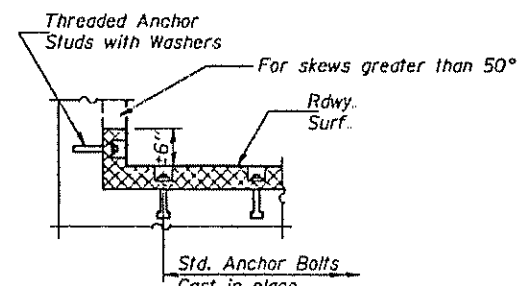

AT WALL

DESIGNED	28
CHECKED	EXAMINED
DRAWN	PASSED
CHECKED	ENGINEER OF BRIDGES AND STRUCTURES

CONTINUOUS SEAL TYPE
NEOPRENE EXPANSION JOINTS
For 2", 2 1/2" and 4" Movement

F.A.I. 55 OVER MACKINAW RIVER
SECTION (57-3-157-3-57-2) RS
MCLEAN COUNTY
STA. 588 + 37.50
S.N. 057-0167 & S.N. 057-0168

F.A.I. RITE	SECTION	COUNTY	TOTAL SHEETS	SHEET NO.
55	#	MCLEAN	139	108

STA. TO STA.
 FED. ROAD DIST. NO. ILLINOIS FED. AID PROJECT
 (57-3-1, 57-3, 57-3-2, 57-2) RS

SHEET 1 of 18

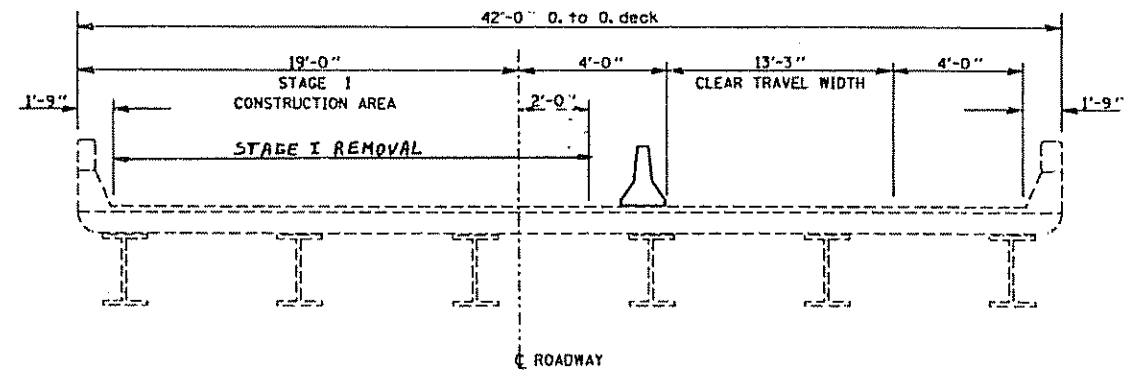
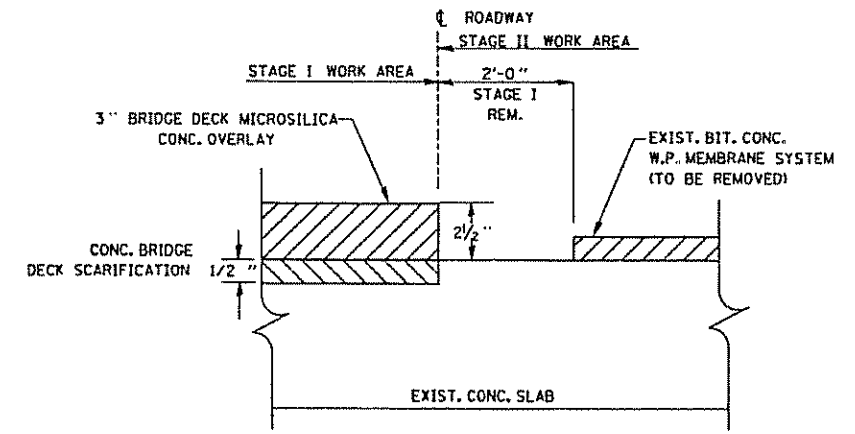

STAGE I
LOOKING SOUTH

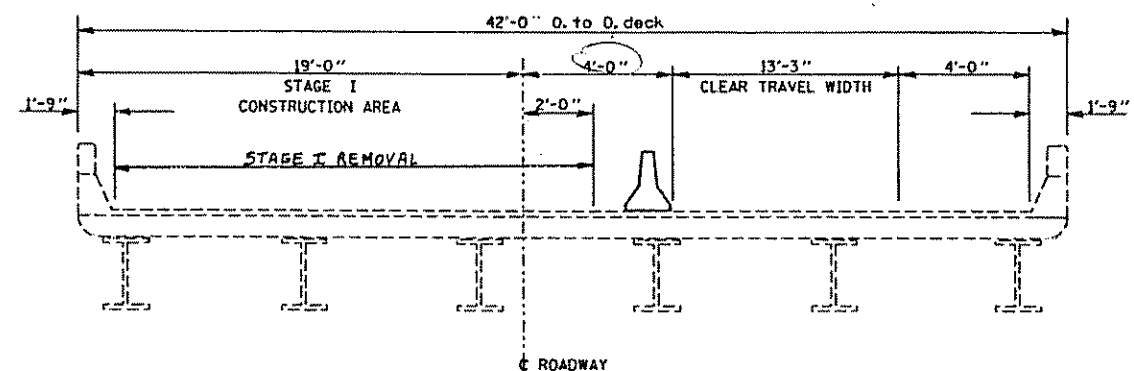

STAGE I
LOOKING NORTH

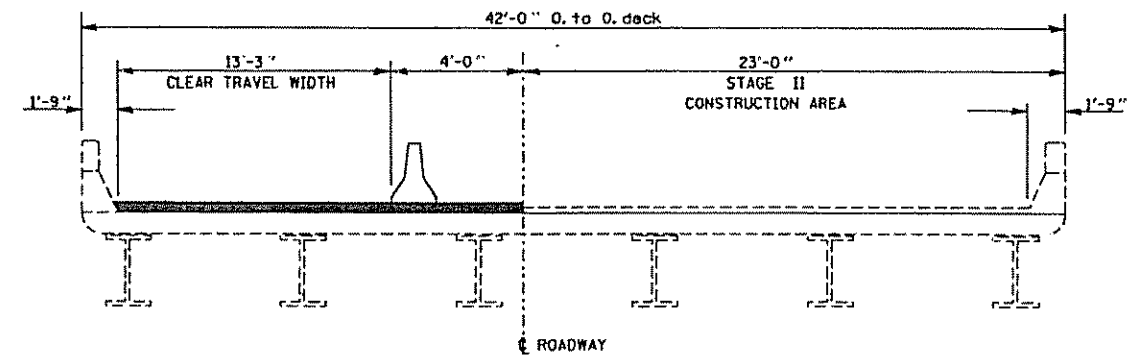

STAGE II
STAGE CONSTRUCTION DIAGRAM
S.N. 057-0169

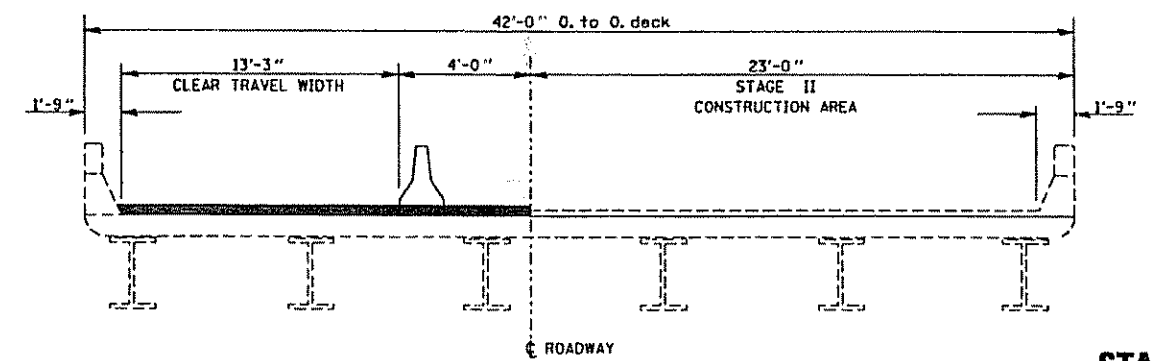

STAGE II
STAGE CONSTRUCTION DIAGRAM
S.N. 057-0170

STAGING DETAILS
F.A.I. 55 OVER TURKEY CREEK
SECTION (57-3-1, 57-3, 57-3-2, 57-2) RS
MCLEAN COUNTY
STA. 608 + 35.40
S.N. 057-0169 & S.N. 057-0170

DEC. 29, 1999
 \ED021001.0574 ILS.DGN

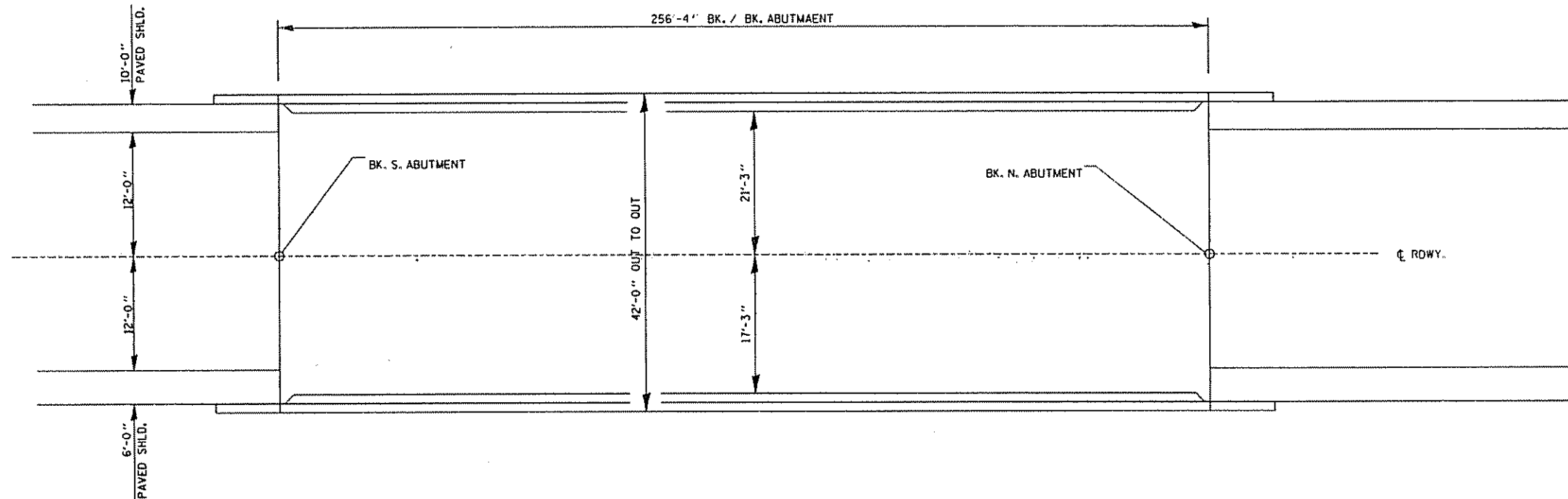

TOTAL BILL OF MATERIALS S.N. 057-0169

CODE NO.	ITEM	UNIT	QUANT
20300100	CHANNEL EXCAVATION	CU YD	500
20700220	POROUS GRANULAR EMBANKMENT	CU YD	114
28100107	STONE RIPRAP, CLASS A4	SQ YD	125
28200100	FILTER FABRIC FOR USE WITH RIPRAP	SQ YD	162
44001000	BITUMINOUS CONCRETE REMOVAL (DECK)	SQ YD	1097
50102400	CONCRETE REMOVAL	CU YD	23
50104650	SLOPE WALL REMOVAL	SQ YD	3
50200100	STRUCTURE EXCAVATION	CU YD	114
50300120	PREFORMED JOINT SEAL - 2 1/2"	FOOT	42
50300155	NEOPRENE EXPANSION JOINT - 2 1/2"	FOOT	41
50300255	CONCRETE SUPERSTRUCTURE	CU YD	23
50300260	BRIDGE DECK GROOVING	SQ YD	1040
50300300	PROTECTIVE COAT	SQ YD	1105
50300310	ELASTOMERIC BEARING ASSEMBLY, TYPE I	EACH	6
50300320	ELASTOMERIC BEARING ASSEMBLY, TYPE II	EACH	6
50500405	FURNISHING AND ERECTING STRUCTURAL STEEL	POUND	4033
50500715	JACK AND REMOVE EXISTING BEARINGS	EACH	12
50800205	REINFORCEMENT BARS, EPOXY COATED	POUND	4248
51100300	SLOPE WALL 6 INCH	SQ YD	3
51205200	TEMPORARY SHEET PILING (REMAIN IN PLACE)	SQ FT	126
X0321468	PLUG EXISTING DECK DRAINS	EACH	6
Z0002600	BAR SPLICERS	EACH	32
Z0006110	BRIDGE DECK MICROSILICA CONCRETE OVERLAY	SQ YD	1097
Z0012200	CONCRETE BRIDGE DECK SCARIFICATION (1/2 INCH)	SQ YD	1084
Z0016001	DECK SLAB REPAIR (FULL DEPTH, TYPE I)	SQ YD	1
Z0016200	DECK SLAB REPAIR (PARTIAL)	SQ YD	6

S.N. 057-0169

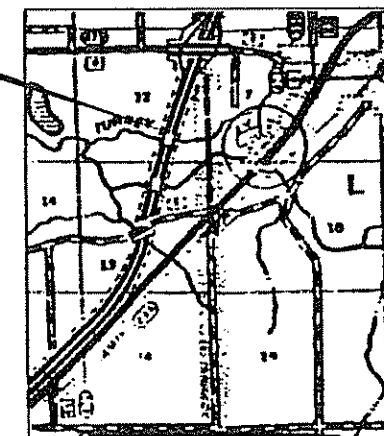

LOCATION SKETCH

NOTE:
SEE SHEET 3 OF 18 FOR GENERAL NOTES.

GENERAL PLAN
F.A.I. 55 OVER TURKEY CREEK
SECTION (57-3-1, 57-3, 57-3-2, 57-2) RS
MCLEAN COUNTY
STA. 608 + 35.40
S.N. 057-0169

F.A.I. RTE.	SECTION	COUNTY	TOTAL SHEETS	SHEET NO.
55	*	MCLEAN	139	110
STA.		TO STA.		
FED. ROAD DIST. NO.		ILLINOIS	FED. AID PROJECT	
* 57-3-1, 57-3, 57-3-2, 57-2) RS				
SHEET 3 of 18				

General Notes

1. All structural steel shall conform to AASHTO Classification M-270 Gr. 36 unless otherwise noted.
2. All Structural steel shall be shop painted with Inorganic zinc rich primer per AASHTO M300, Type 1. The cost shall be included in the cost of Furnishing and Erecting Structural Steel.
3. The existing structural steel contains lead. The Contractor should take appropriate precautions to deal with the presence of lead on this project.
4. Reinforcement bars shall conform to the requirements of AASHTO M-31, M-42 or M-53 Grade 60.
5. Any reinforcement bars that are damaged during concrete removal shall be replaced with an approved bar splicer or anchorage system. Cost shall be included in the cost of "Concrete Removal".
6. Existing longitudinal reinforcement extending into the removed area shall be cleaned, straightened and incorporated into the new construction. Existing transverse reinforcement may be cut as shown and removed.
7. Prior to pouring the new concrete for the deck, all loose rust, loose mill scale and all other loose, detrimental foreign material shall be removed from the portions of flanges of beams in contact with concrete. The removal shall be accomplished according to the requirements of the SSPC Surface Preparation Specifications SP-3 for power tool cleaning or SP-2 for hand tool cleaning. Cost shall be included in the cost of "Concrete Superstructure".
8. Joint openings shall be adjusted according to Article 503.10(c) of the Standard Specifications when the deck is poured at an ambient temperature other than 50 degrees Fahrenheit.
9. Plan dimensions and details relative to existing structure have been taken from existing plans and are subject to nominal construction variations. It shall be the Contractor's responsibility to verify such dimensions and details in the field and make necessary approved adjustments prior to construction or ordering of materials. Such variations shall not be cause for additional compensation for a change in the scope of the work, however, the Contractor will be paid for the quantity actually furnished at the unit price bid for the work.

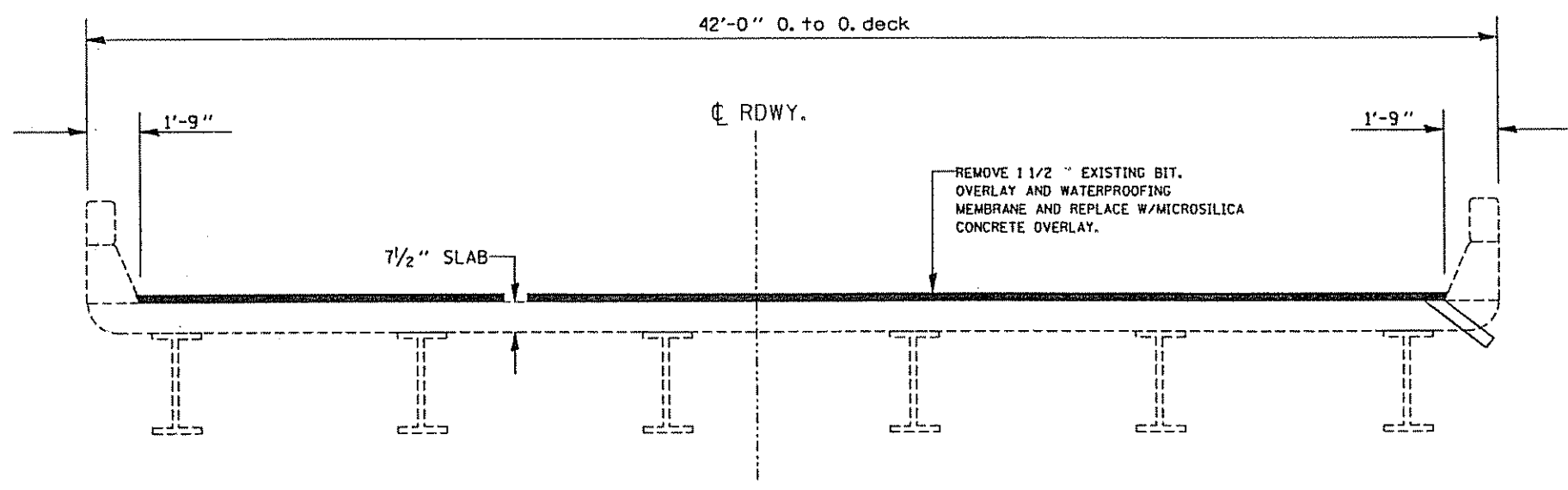

CROSS SECTION
LOOKING SOUTH

GENERAL NOTES AND TYPICAL SECTION
F.A.I. 55 OVER TURKEY CREEK
SECTION (57-3-1, 57-3, 57-3-2, 57-2) RS
MCLEAN COUNTY
STA. 608 + 35.4
S.N. 057-0169

DEC. 28, 1999
VED02/00/DETAILS.DGN

F.A.I. RTE.	SECTION	COUNTY	TOTAL SHEETS	SHEET NO.
55	*	MCLEAN	139	111
STA.		TO STA.		
FED. ROAD DIST. NO.	ILLINOIS	FED. AID PROJECT		
* (57-3-1, 57-3, 57-3-2, 57-2) RS				

SHEET 4 of 18

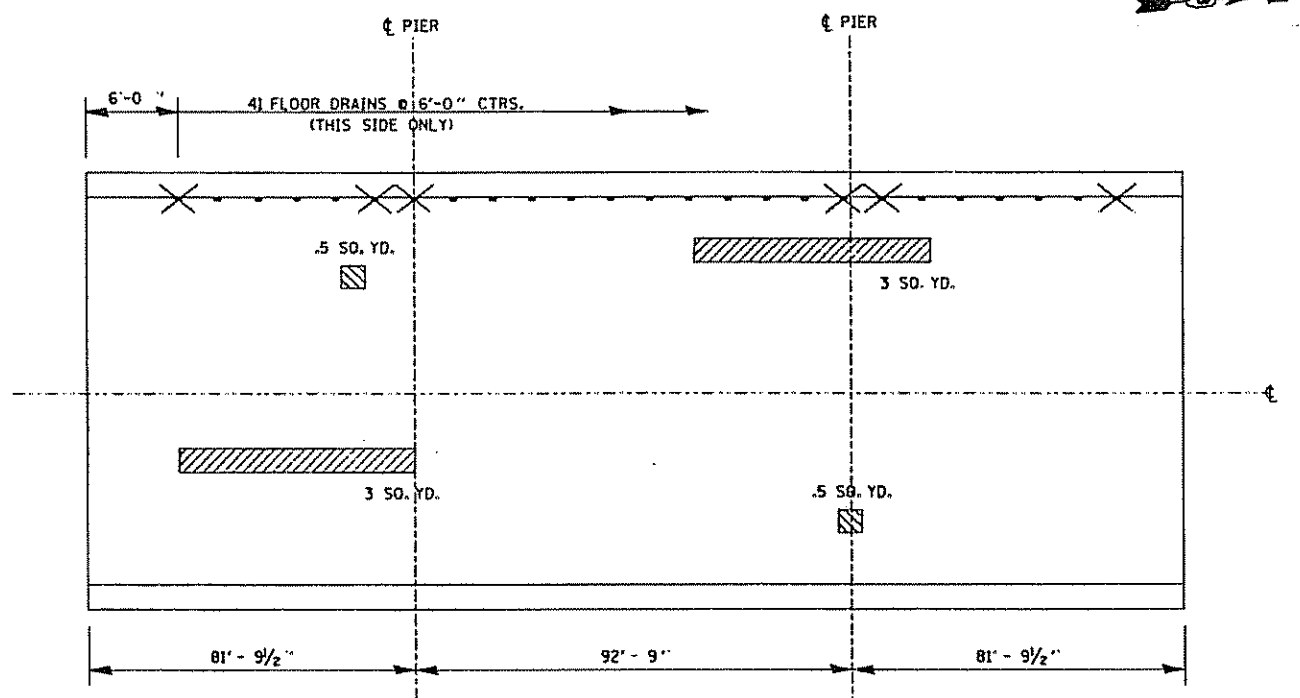

NOTES:

AREA OF DECK REPAIRS SHOWN ARE ESTIMATED. THE ENGINEER SHALL SHOW ACTUAL LOCATIONS OF DECK REPAIRS ON AS-BUILT PLANS.

EXISTING DECK DRAINS LOCATED WITHIN 10 FT. OF A PIER OR AN ABUTMENT SHALL BE ELIMINATED.

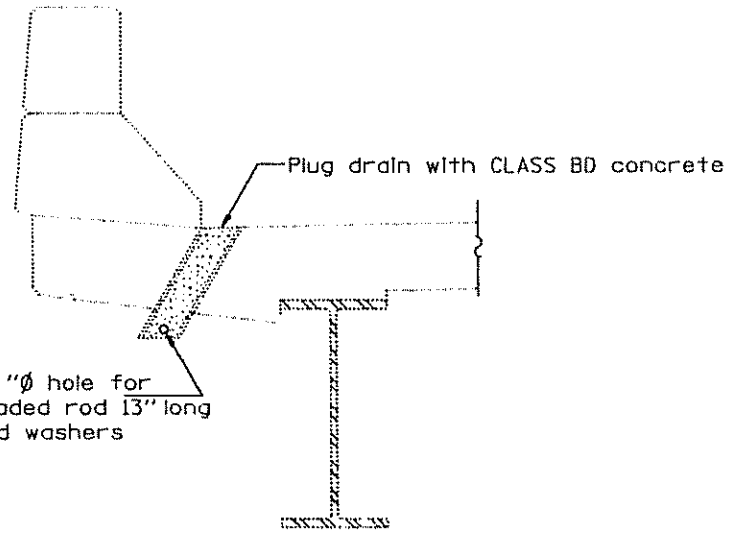

Field drill 3/8" hole for 1/4" threaded rod 13" long with nuts and washers

SECTION AT DRAIN

DRAIN ELIMINATION DETAILS

	UNIT	STAGE I	STAGE II	TOTAL
✕ PLUG EXISTING DECK DRAINS	EA	6	0	6
▨ DECK SLAB REPAIR (PARTIAL DEPTH)	SO. YD.	3	3	6
▨ DECK SLAB REPAIR (FULL DEPTH)	SO. YD.	.5	.5	1

DECK SURVEY DATE: FEBRUARY 9, 1999

DECK REPAIR PLAN
F.A.I. 55 OVER TURKEY CREEK
SECTION (57-3-1, 57-3, 57-3-2, 57-2) RS
MCLEAN COUNTY
STA. 608 + 35.40
S.N. 057-0169

F.A.I. RTE.	SECTION	COUNTY	TOTAL SHEETS	SHEET NO.
55	*	MCLEAN	139	112

STA. TO STA.



FED. ROAD DIST. NO. ILLINOIS FED. AID PROJECT

* (57-3-1, 57-3, 57-3-2, 57-2) RS

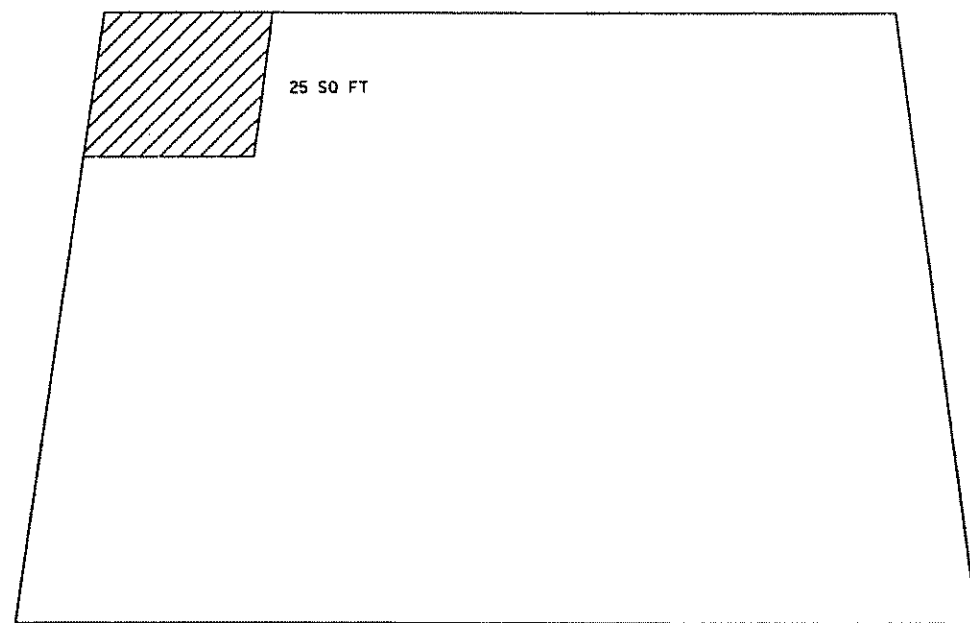
SHEET 5 of 18



SOUTH SLOPEWALL

	SLOPEWALL REMOVAL = 25 SQ FT
	CONCRETE SLOPEWALL = 25 SQ FT

**SLOPEWALL, BACKWALL & WINGWALL CRACKS
AND SPALLS**
S.N. 057-0169

ABUTMENT REPAIRS
F.A.I. 55 OVER TURKEY CREEK
SECTION (57-3-1, 57-3, 57-3-2, 57-2) RS
MCLEAN COUNTY
STA. 608 + 35.40
S.N. 057-0169

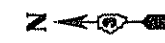

F.A.I. RTE.	SECTION	COUNTY	TOTAL SHEETS	SHEET NO.
55	#	MCLEAN	139	113
STA.		TO STA.		
FED. ROAD DIST. NO.		ILLINOIS	FED. AID PROJECT	
* (57-3-1, 57-3, 57-3-2, 57-2) RS				
SHEET 6 of 18				

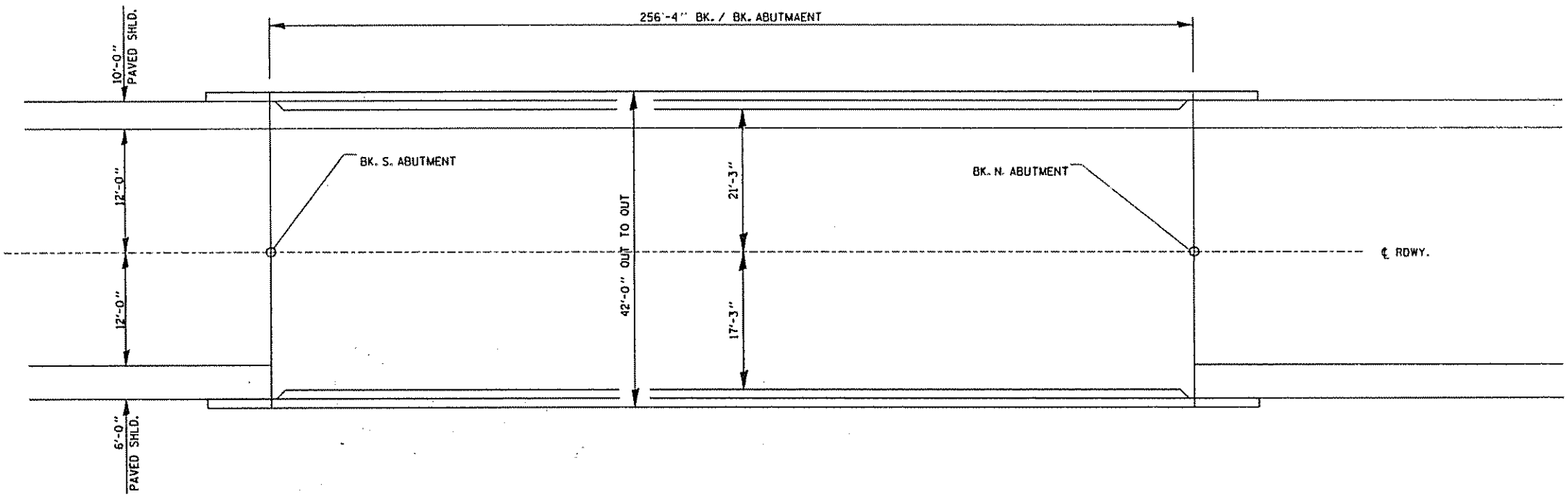

TOTAL BILL OF MATERIALS S.N. 057-0170

CODE NO.	ITEM	UNIT	QUANT
20300100	CHANNEL EXCAVATION	CU YD	500
20700220	POROUS GRANULAR EMBANKMENT	CU YD	57
28100107	STONE RIPRAP, CLASS A4	SQ YD	125
28200100	FILTER FABRIC FOR USE WITH RIPRAP	SQ YD	162
44001000	BITUMINOUS CONCRETE REMOVAL (DECK)	SQ YD	1097
50102400	CONCRETE REMOVAL	CU YD	12.7
50200100	STRUCTURE EXCAVATION	CU YD	57
50300120	PREFORMED JOINT SEAL - 4"	FOOT	42
50300155	NEOPRENE EXPANSION JOINT - 2 1/2"	FOOT	41
50300255	CONCRETE SUPERSTRUCTURE	CU YD	12.8
50300260	BRIDGE DECK GROOVING	SQ YD	1040
50300300	PROTECTIVE COAT	SQ YD	1105
50300310	ELASTOMERIC BEARING ASSEMBLY, TYPE I	EACH	6
50300320	ELASTOMERIC BEARING ASSEMBLY, TYPE II	EACH	6
50500405	FURNISHING AND ERECTING STRUCTURAL STEEL	POUND	4033
50500715	JACK AND REMOVE EXISTING BEARINGS	EACH	12
50800205	REINFORCEMENT BARS, EPOXY COATED	POUND	2364
51205200	TEMPORARY SHEET PILING (REMAIN IN PLACE)	SQ FT	63
X0321468	PLUG EXISTING DECK DRAINS	EACH	6
Z0002600	BAR SPLICERS	EACH	24
Z0006110	BRIDGE DECK MICROSILICA CONCRETE OVERLAY	SQ YD	1097
Z0012200	CONCRETE BRIDGE DECK SCARIFICATION (1/2 INCH)	SQ YD	1084
Z0016001	DECK SLAB REPAIR (FULL DEPTH, TYPE I)	SQ YD	1
Z0016200	DECK SLAB REPAIR (PARTIAL)	SQ YD	28

NOTE:
SEE SHEET 7 OF 18 FOR GENERAL NOTES.

S.N. 057-0170

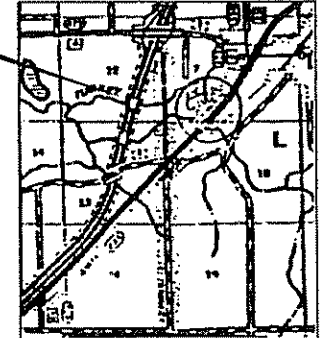

LOCATION SKETCH

GENERAL PLAN
F.A.I. 55 OVER TURKEY CREEK
SECTION (57-3-1, 57-3, 57-3-2, 57-2) RS
MCLEAN COUNTY
STA. 608 + 35.40
S.N. 057-0170

F.A.I. SHEET NO.	SECTION	COUNTY	TOTAL SHEETS	SHEET NO.
55	*	MCLEAN	139	119
STA.		TO STA.		
FED. ROAD DIST. NO.	ILLINOIS	FED. AID PROJECT		
* 57-3-1, 57-3, 57-3-2, 57-21 RS				

SHEET 7 of 18

General Notes

1. All structural steel shall conform to AASHTO Classification M-270 Gr. 36 unless otherwise noted.
2. All Structural steel shall be shop painted with inorganic zinc rich primer per AASHTO M300, Type 1. The cost shall be included in the cost of Furnishing and Erecting Structural Steel.
3. The existing structural steel contains lead. The Contractor should take appropriate precautions to deal with the presence of lead on this project.
4. Reinforcement bars shall conform to the requirements of AASHTO M-31, M-42 or M-53 Grade 60.
5. Any reinforcement bars that are damaged during concrete removal shall be replaced with an approved bar splicer or anchorage system. Cost shall be included in the cost of "Concrete Removal".
6. Existing longitudinal reinforcement extending into the removed area shall be cleaned, straightened and incorporated into the new construction. Existing transverse reinforcement may be cut as shown and removed.
7. Prior to pouring the new concrete for the deck, all loose rust, loose mill scale and all other loose, detrimental foreign material shall be removed from the portions of flanges of beams in contact with concrete. The removal shall be accomplished according to the requirements of the SSPC Surface Preparation Specifications SP-3 for power tool cleaning or SP-2 for hand tool cleaning. Cost shall be included in the cost of "Concrete Superstructure".
8. Joint openings shall be adjusted according to Article 503.10(c) of the Standard Specifications when the deck is poured at an ambient temperature other than 50 degrees Fahrenheit.
9. Plan dimensions and details relative to existing structure have been taken from existing plans and are subject to nominal construction variations. It shall be the Contractor's responsibility to verify such dimensions and details in the field and make necessary approved adjustments prior to construction or ordering of materials. Such variations shall not be cause for additional compensation for a change in the scope of the work, however, the Contractor will be paid for the quantity actually furnished at the unit price bid for the work.

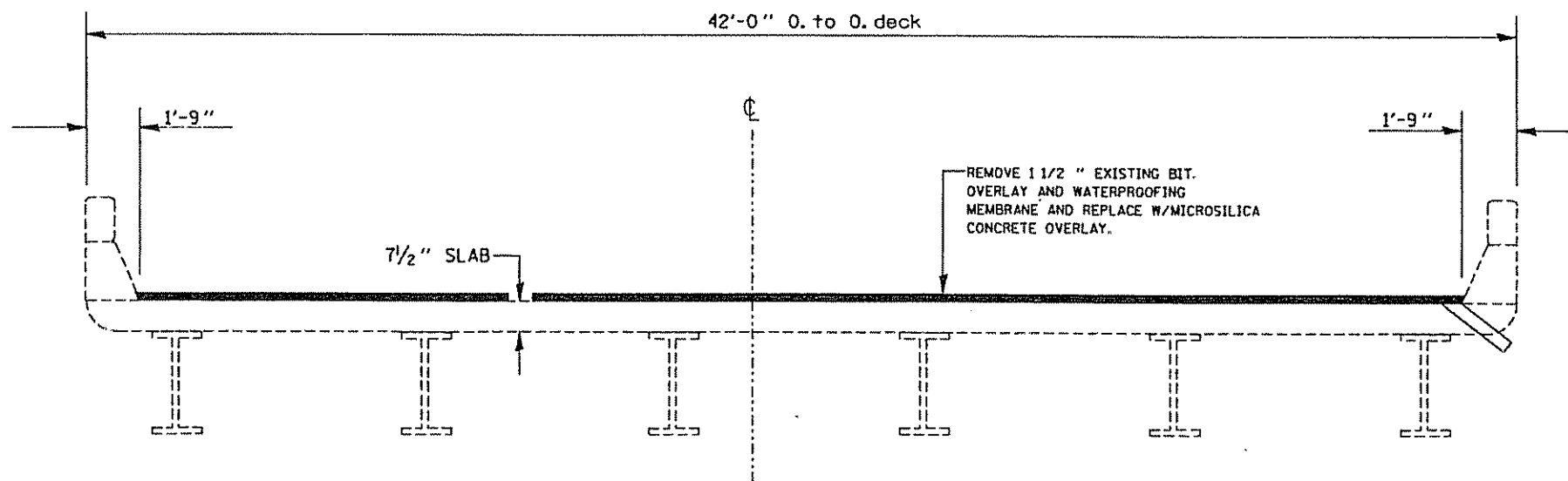

CROSS SECTION
LOOKING NORTH

GENERAL NOTES AND TYPICAL SECTION
F.A.I. 55 OVER TURKEY CREEK
SECTION (57-3-1, 57-3, 57-3-2, 57-2) RS
MCLEAN COUNTY
STA. 608 + 35.4
S.N. 057-0170

F.A.I. RTE.	SECTION	COUNTY	TOTAL SHEETS	SHEET NO.
55	*	MCLEAN	139	119
STA.		TO STA.		
FED. ROAD DIST. NO.		ILLINOIS FED. AID PROJECT		
* 57-3-1, 57-3, 57-3-2, 57-21 RS				

SHEET 8 of 18

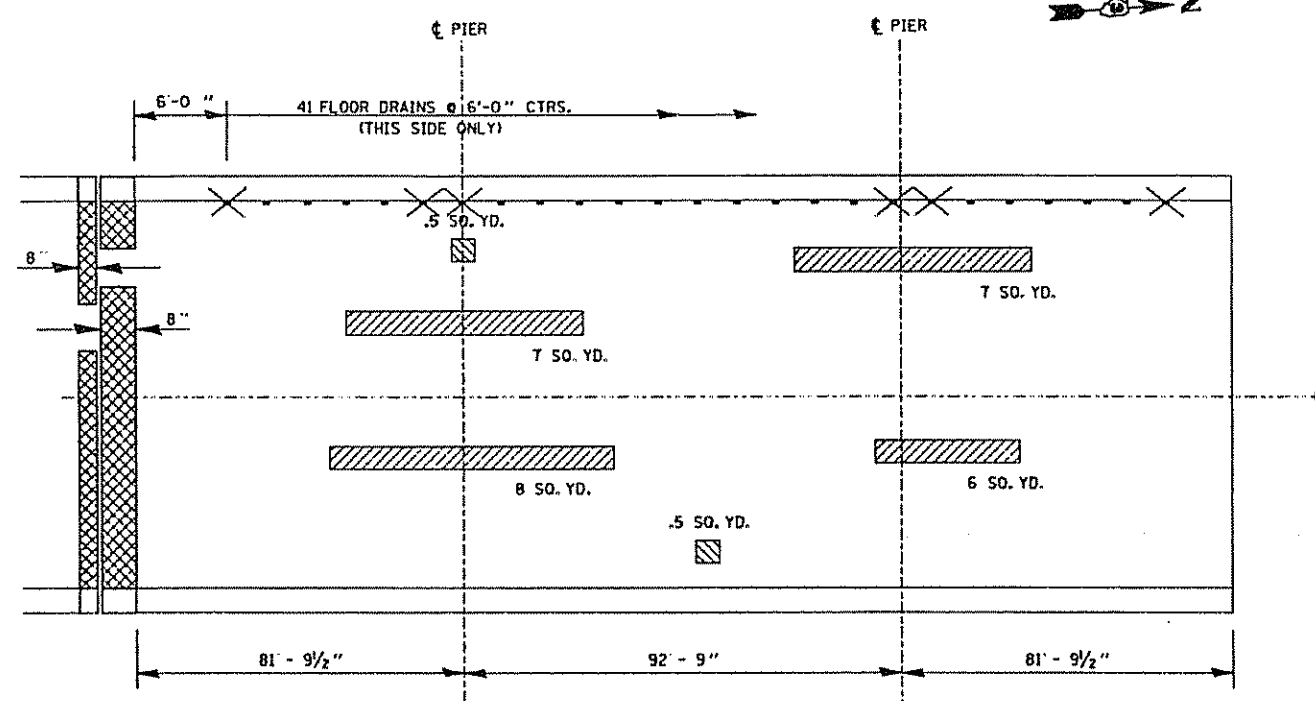

NOTES:

AREA OF DECK REPAIRS SHOWN ARE ESTIMATED. THE ENGINEER SHALL SHOW ACTUAL LOCATIONS OF DECK REPAIRS ON AS-BUILT PLANS.

EXISTING DECK DRAINS LOCATED WITHIN 10 FT. OF A PIER OR AN ABUTMENT SHALL BE ELIMINATED.

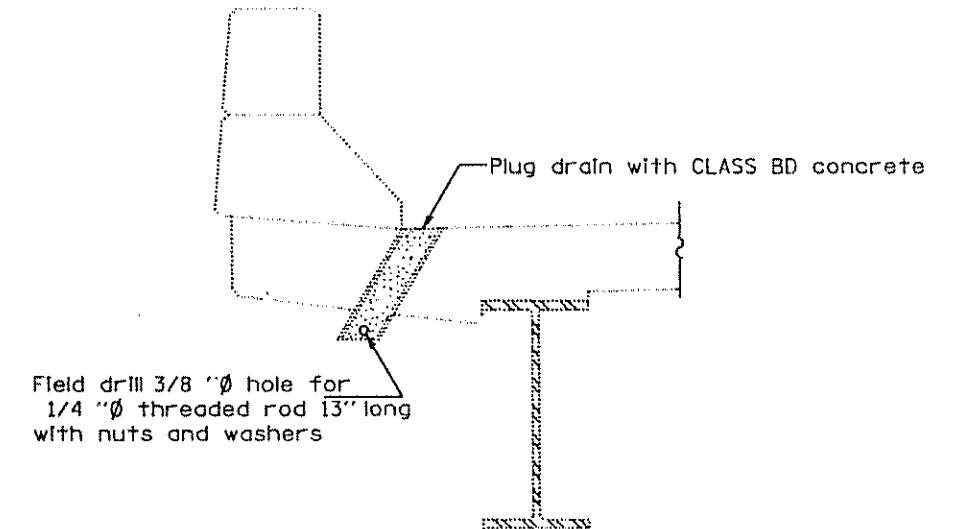

SECTION AT DRAIN
DRAIN ELIMINATION DETAILS

	UNIT	STAGE I	STAGE II	TOTAL
CONC. REMOVAL	CU. YD.	.7	.5	1.2
CONC. SUPERSTRUCTURE	CU. YD.	.7	.5	1.2
PLUG EXISTING DECK DRAINS	EACH	0	6	6
DECK SLAB REPAIR (PARTIAL DEPTH)	SQ. YD.	14	14	28
DECK SLAB REPAIR (FULL DEPTH)	SQ. YD.	.5	.5	1

DECK SURVEY DATE: FEBRUARY 9, 1999

DECK REPAIR PLAN
F.A.I. 55 OVER TURKEY CREEK
SECTION (57-3-1, 57-3, 57-3-2, 57-2) RS
MCLEAN COUNTY
STA. 608 + 35.40
S.N. 057-0170

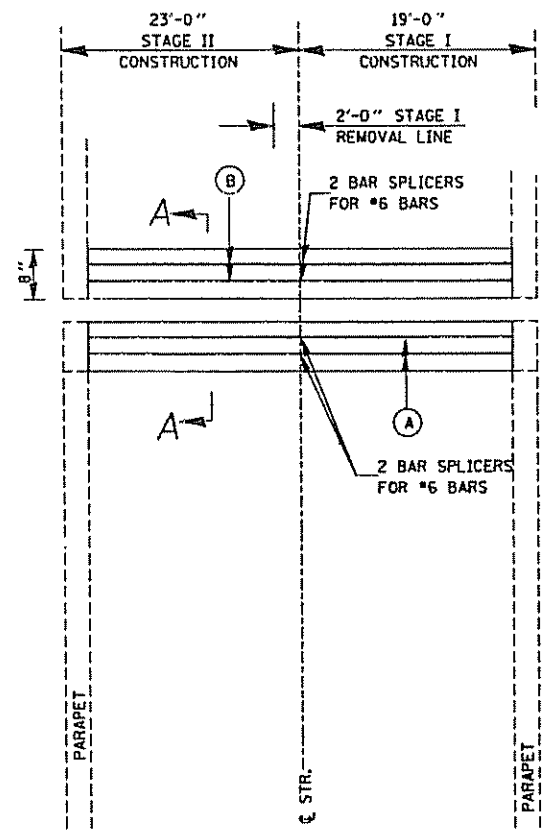

- SEE DETAIL A & SECTION A-A
- BARS REQUIRED FOR EACH STAGE**
- (A) 2- #6 a (E) Bars Stage I, (a₂(E) Bars - Stage II)
 - (B) 2- #6 a (E) Bar Stage I, (a₂(E) Bars - Stage II)

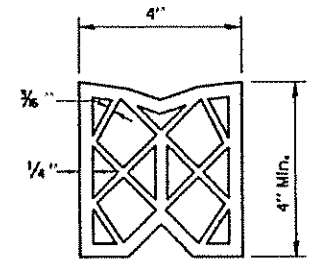

**PREFORMED JOINT SEAL (4")
(NORTH ABUTMENT)**

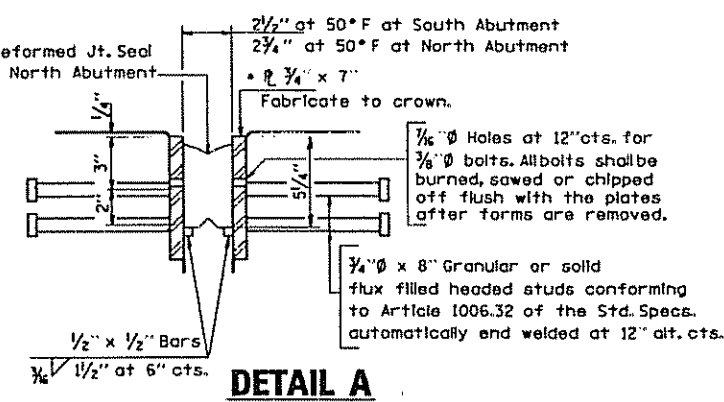

DETAIL A

• Furnish in segments of 20 ft. maximum length. Maximum space between installed segments shall be 3/8". Seal space with Silicone Sealant suitable for Structural Steel.

NOTES:

1. THE LIMITS OF ALL CONCRETE REMOVAL SHALL BE SAW CUT 3/4" INTO CONCRETE.
2. EXISTING LONGITUDINAL BARS IN DECK AND VERTICAL BARS IN ABUTMENT BACKWALL EXTENDING INTO THE REMOVED AREA SHALL BE CLEANED, STRAIGHTENED, AND INCORPORATED IN THE NEW WORK.
3. EXISTING PARAPET REINFORCEMENT EXTENDING INTO THE REMOVED AREA SHALL BE CLEANED, STRAIGHTENED AND INCORPORATED INTO THE NEW CONSTRUCTION.
4. THE REMOVAL AND REPLACEMENT OF CONCRETE AT THE ABUTMENT BACKWALL AND DECK WILL BE PAID FOR AS CONCRETE REMOVAL AND CONCRETE SUPERSTRUCTURE.
5. THE PARAPET SHALL REMAIN IN PLACE. CONCRETE REMOVAL AT THE ABUTMENT AND DECK SIDE SHALL BE FROM FACE OF PARAPET TO FACE OF PARAPET.
6. THE REMOVAL OF EXISTING PJS, NEOPRENE JOINT SEAL AND STEEL ARMOUR SHALL BE INCLUDED IN THE COST OF "CONCRETE REMOVAL".

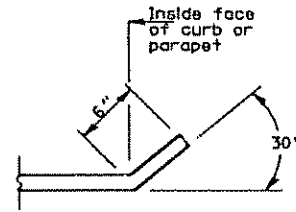

END OF PLATE

BILL OF MATERIAL SN 057-0170				
BAR	NO.	SIZE	LENGTH (FT.)	SHAPE
a(E)	4	#6	17'-0"	—
a ₂ (E)	4	#6	21'-0"	—
CONCRETE REMOVAL			CU YD	1.2
CONC. SUPERSTRUCTURE			CU YD	1.2
BAR SPLICERS			EACH	8
REINFORCEMENT BARS, EPOXY COATED			POUND	228

REINFORCEMENT BARS DESIGNATED (E) SHALL BE EPOXY COATED

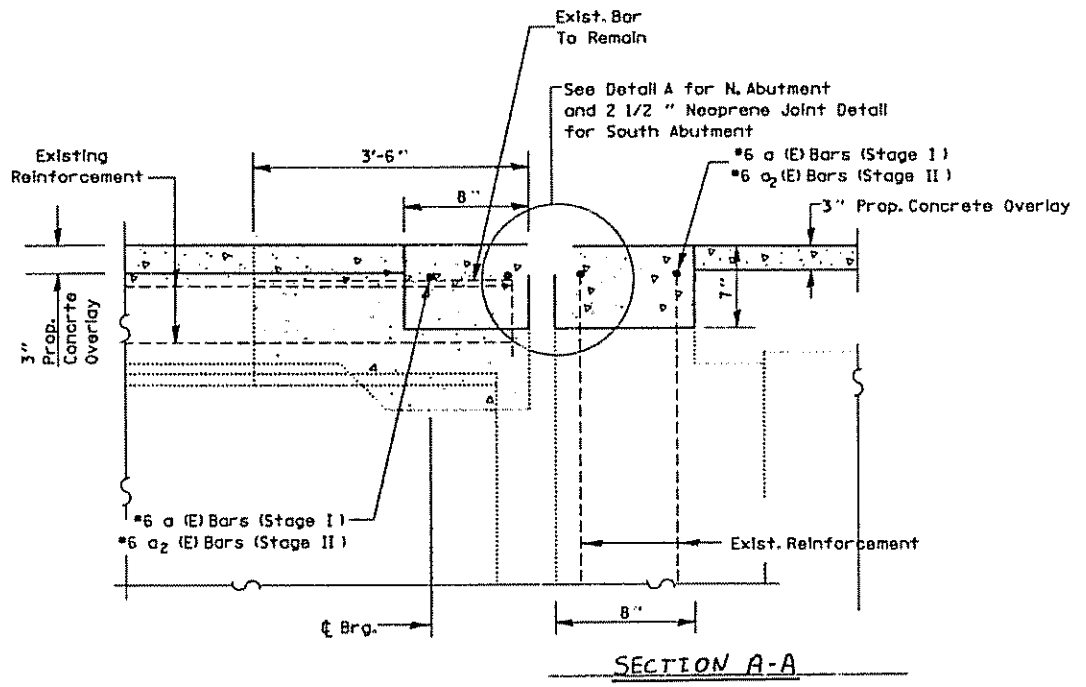

SECTION A-A

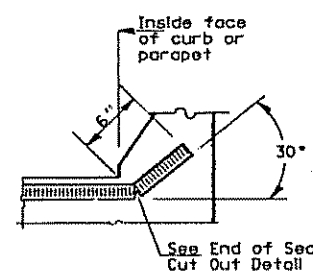

END OF SEAL

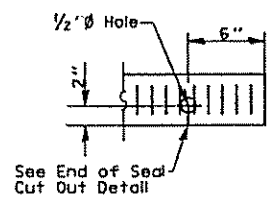

SEAL CUT-OUT 4"

**EXPANSION JOINT REPLACEMENT DETAILS
F.A.I. 55 OVER TURKEY CREEK
SECTION (57-3-1, 57-3, 57-3-2, 57-2) RS
MCLEAN COUNTY
STA. 608 + 35.4
S.N. 057-0170**

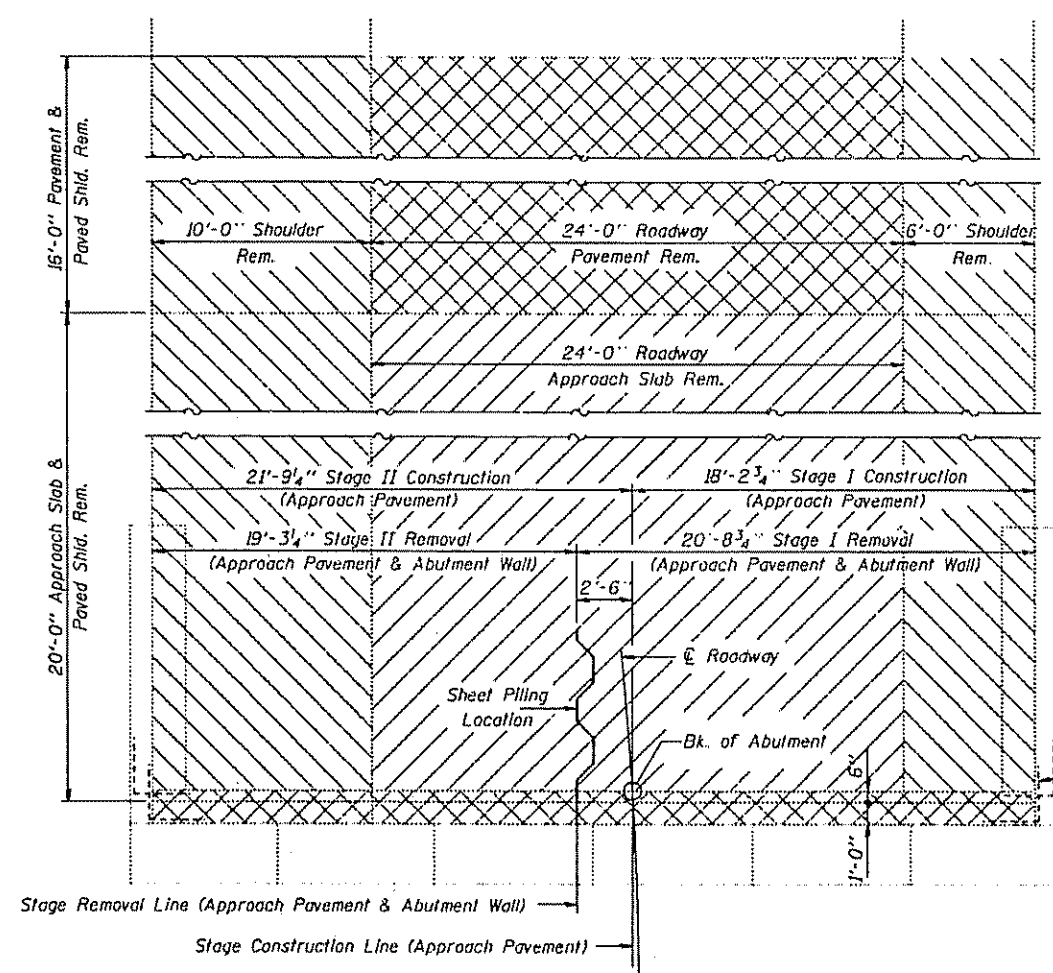

EXISTING PLAN

Hatched areas indicate Pavement & Shoulder Removal.
 Cross Hatched areas indicate Concrete Removal.
 * Existing reinforcement to be cleaned, straightened and incorporated into the new construction.

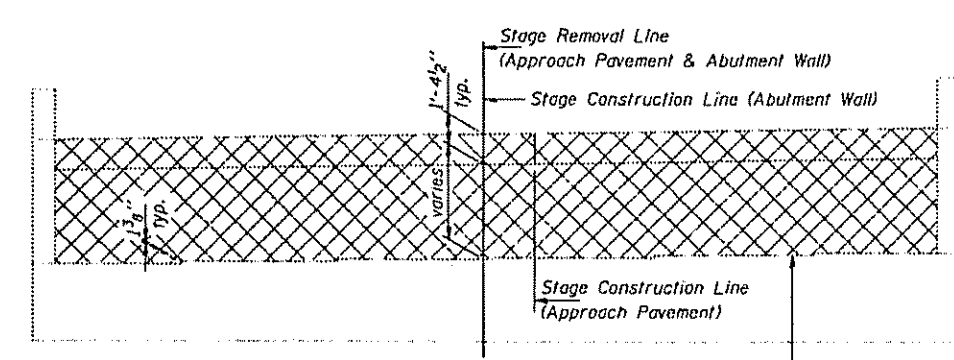

EXISTING ELEVATION

Existing construction joint. If there is no joint present saw cut back of wall 3/4" as directed by the Engineer.

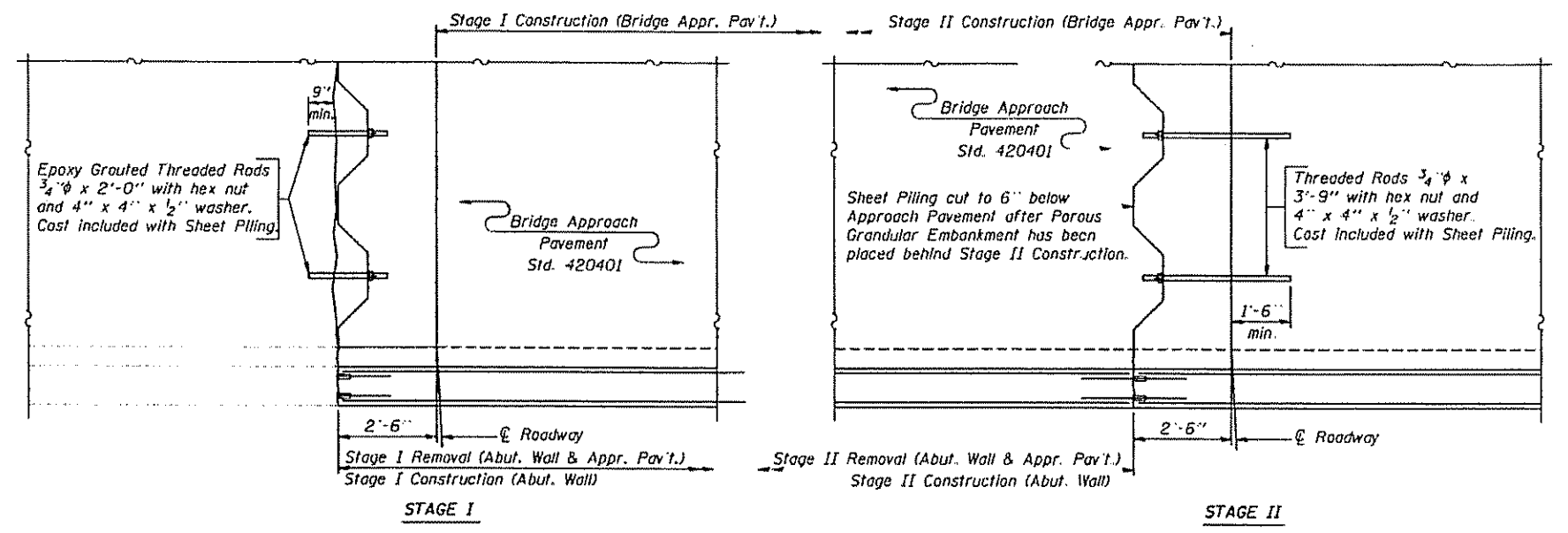

SHEET PILING PLACEMENT PLAN

* Existing #5 hooked bars to remain.

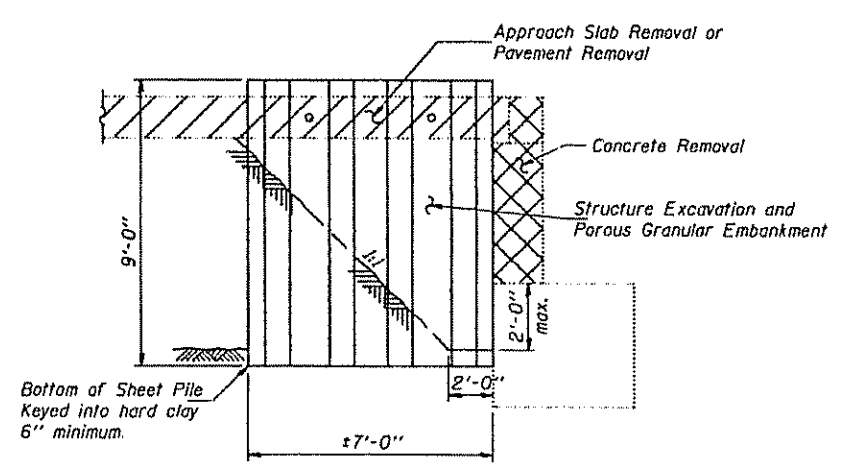

SHEET PILING DETAIL

Sheet Piling minimum section modulus = 2.5 cu. in./ft. of wall.
 After the porous granular embankment has been placed behind the abutment wall constructed during Stage II, the sheet piling shall be cut at an elevation 6" below the proposed Approach Pavement and shall be left in place.

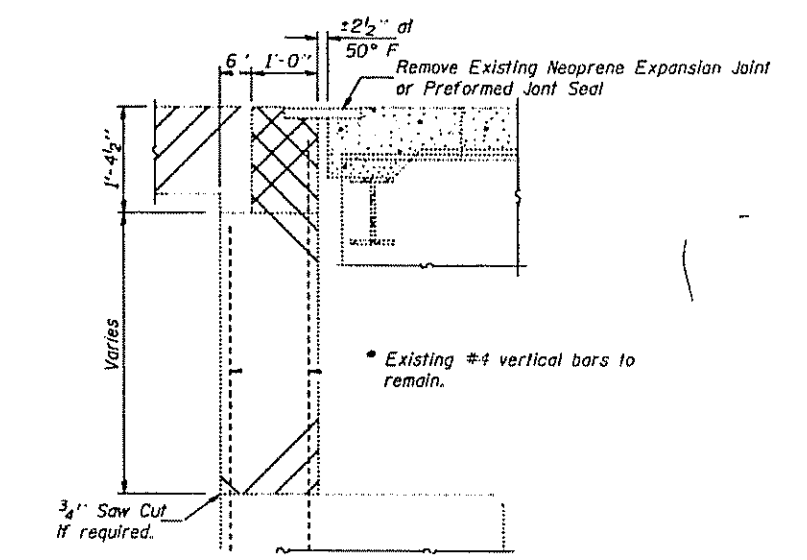

SECTION THRU EXISTING ABUTMENT

BRIDGE REPAIRS
F.A.I. 55 OVER TURKEY CREEK
SECTION (57-3-1, 57-3, 57-3-2, 57-2) RS
MCLEAN COUNTY
STA. 608+35.40
S.N. 057-0169 - NORTH & SOUTH ABUTMENTS
S.N. 057-0170 - NORTH ABUTMENT

F.A.I. RTE.	SECTION	COUNTY	TOTAL SHEETS	SHEET NO.
55	*	MCLEAN	139	118
STA.	TO STA.			
FED. ROAD DIST. NO.	ILLINOIS	FED. AID PROJECT		
* 57-3-1, 57-3-2, 57-3-2, 57-21 RS				

SHEET 11 of 18

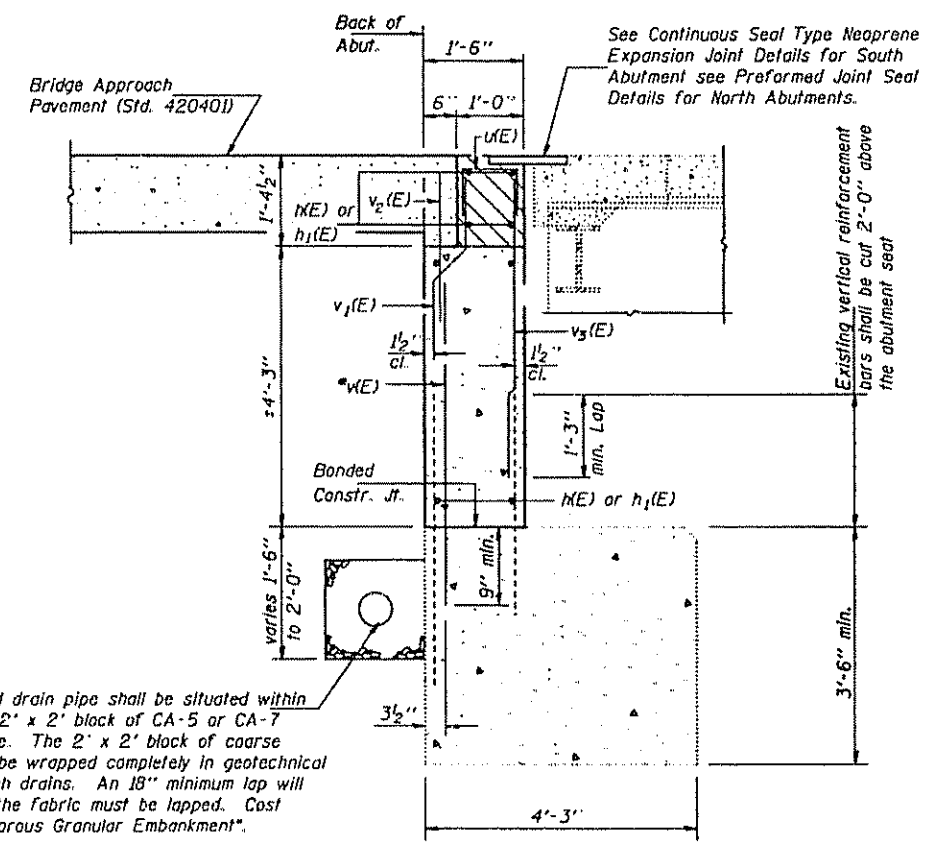

A 6" perforated drain pipe shall be situated within an approximate 2' x 2' block of CA-5 or CA-7 coarse aggregate. The 2' x 2' block of coarse aggregate shall be wrapped completely in geotechnical fabric for french drains. An 18" minimum lap will be used where the fabric must be lapped. Cost included with "Pareus Granular Embankment".

SEC. THRU PROPOSED ABUT.

* Drill and grout in accordance with BSP-II

Remove 8" hole from existing concrete wingwall, extend 6" hole through wall and grout in place. (typical)

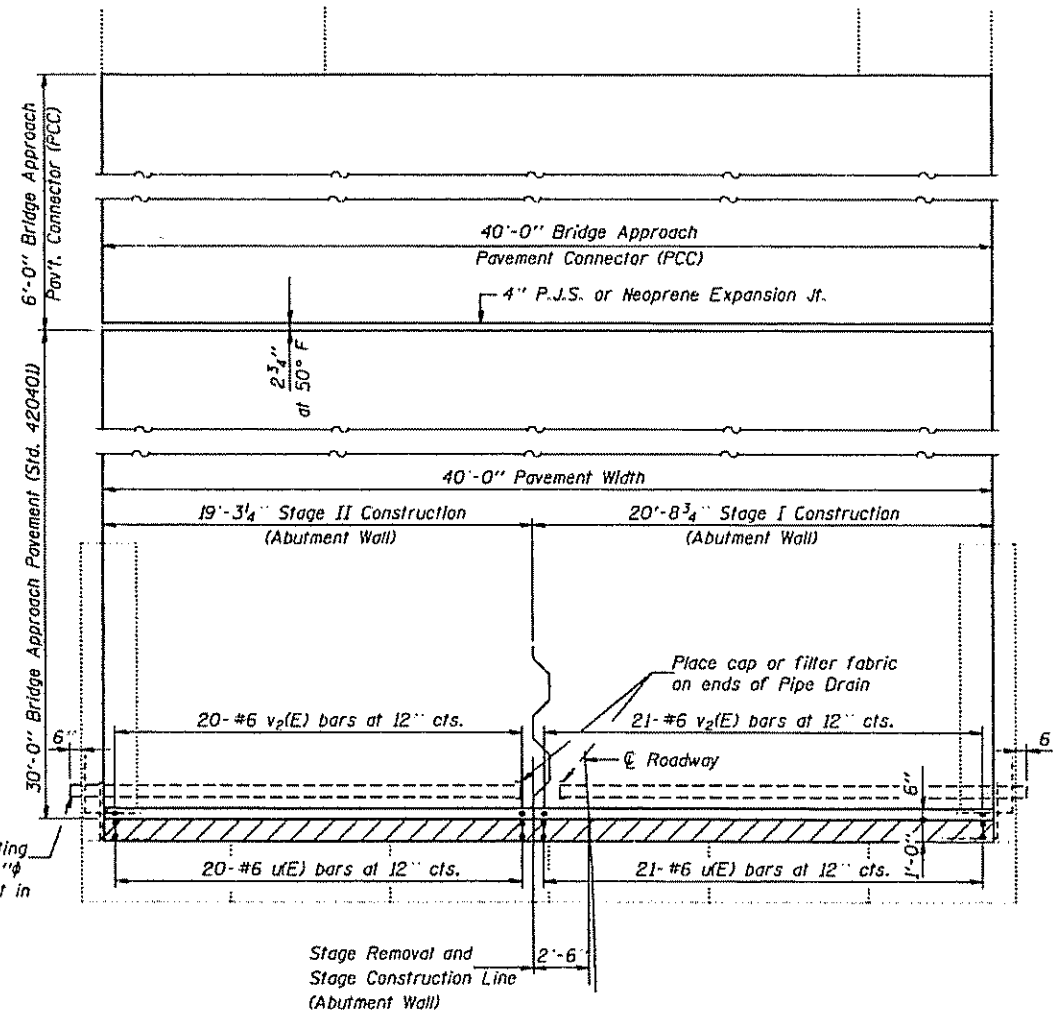

PROPOSED PLAN

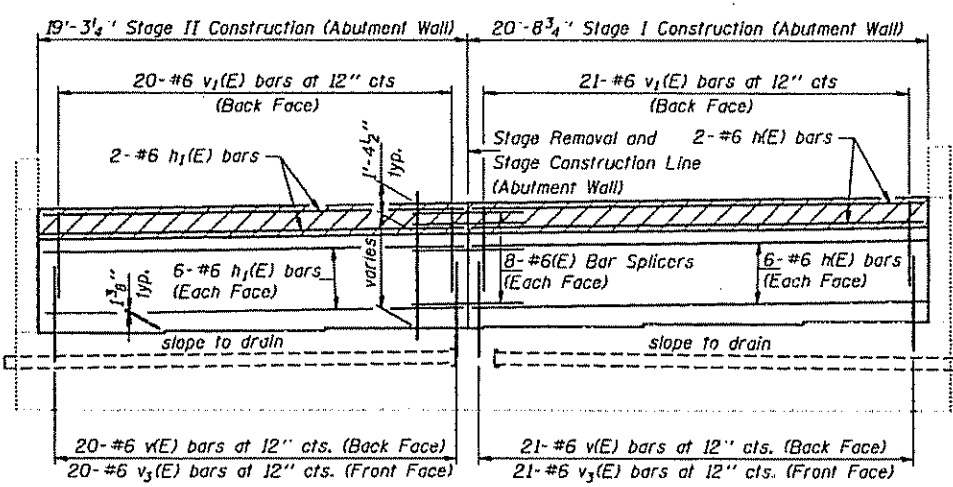

PROPOSED ELEVATION

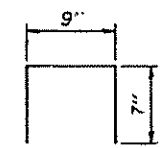
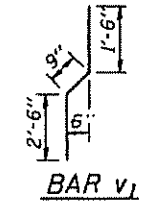

BILL OF MATERIAL *

Bar	No.	Size	Length	Shape
v1(E)	41	#6	4'-10"	—
v2(E)	41	#6	4'-9"	—
v3(E)	41	#6	2'-2"	—
v3(E)	41	#6	5'-3"	—
h(E)	16	#6	20'-5"	—
h1(E)	16	#6	19'-0"	—
u (E)	41	#6	1'-11"	□
Concrete Removal			Cu. Yd.	11.5
Concrete Superstructure			Cu. Yd.	11.5
Reinforcement Bars, Epoxy Coated			Lbs.	2112
Bar Splicers			Each	16

Reinforcement bars designated (E) shall be epoxy coated. Reinforcement bars shall conform to the requirements of AASHTO M-31, M-42 or M-53 Grade 60. * Quantities shown are for each abutment

BRIDGE REPAIRS
F.A.I. 55 OVER TURKEY CREEK
SECTION (57-3-1, 57-3, 57-3-2, 57-2) RS
MCLEAN COUNTY
STA. 608 + 35.40
S.N. 057-0169 - NORTH & SOUTH ABUTMENTS
S.N. 057-0170 - NORTH ABUTMENT

F.A.I. RTE.	SECTION	COUNTY	TOTAL SHEETS	SHEET NO.
55	•	MCLEAN	139	11
STA.		TO STA.		
FED. ROAD DIST. NO.	ILLINOIS	FED. AID PROJECT		
• (57-3-1, 57-3, 57-3-2, 57-2) RS				
SHEET 12 of 18				

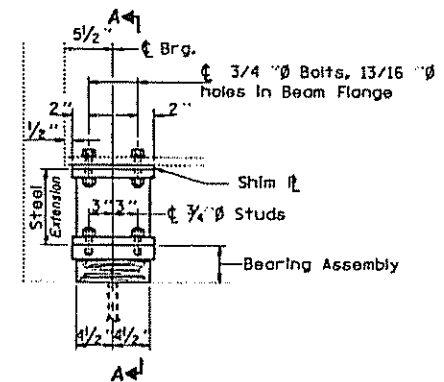

ELEVATION AT NORTH ABUTMENT

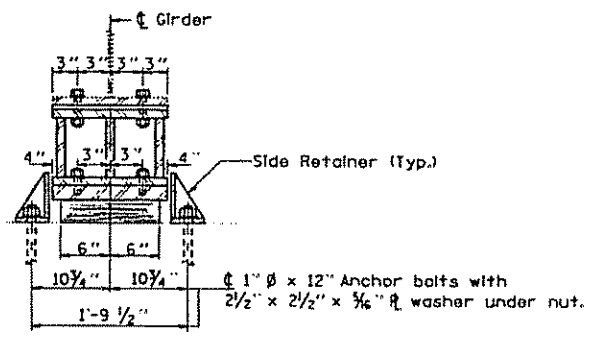

SECTION A-A

TYPE I ELASTOMERIC EXP. BRG.

GIRDER REACTIONS

RP	(K)	35.5
RL	(K)	40.6
Imp.	(K)	10.4
R (Total)	(K)	86.5

Notes: Diaphragm removal and replacement may be required to facilitate drilling holes. Cost shall be included in the cost of "Furnishing and Erecting Structural Steel".
New steel extensions, side retainers, shim's, connection bolts, and anchor bolts are included in "Furnishing and Erecting Structural Steel".
See Sheet 17 of 18 for Anchor Bolt Installation.
Prior to ordering any material, the Contractor shall verify in the field all bearing height and shim thickness dimensions.
Min. Jack capacity = 45 Tons
Two 1/8" shims of the dimensions of the bottom bearing plate shall be provided for each bearing in addition to all other plates or shims.

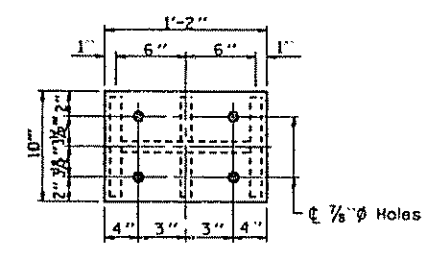

PLAN TOP AND BOTTOM PLATE

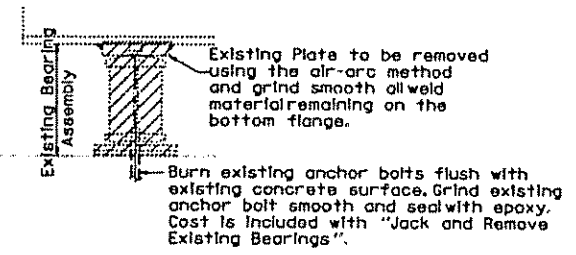

EXISTING BEARING REMOVAL DETAIL

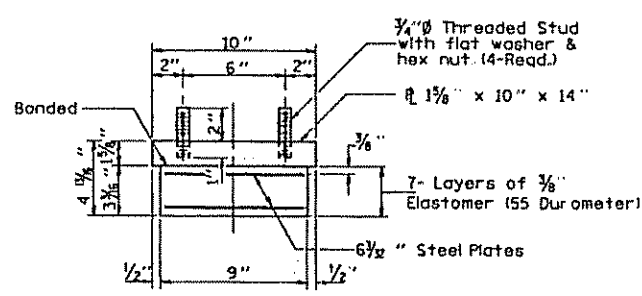

BEARING ASSEMBLY

Note: Shim plates shall not be placed under Bearing Assembly.

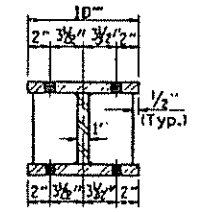

SECTION B-B

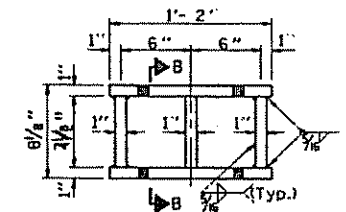

STEEL EXTENSION DETAIL

ADDITIONAL SOLID 1 PIECE SHIMS REQUIRED						
	Beam #1 (West)	2	3	4	5	6 (East)
S.N. 057-0169	1/2"	3/8"	—	—	3/8"	1/2"
S.N. 057-0170	3/8"	1/2"	3/8"	3/8"	3/8"	1/4"

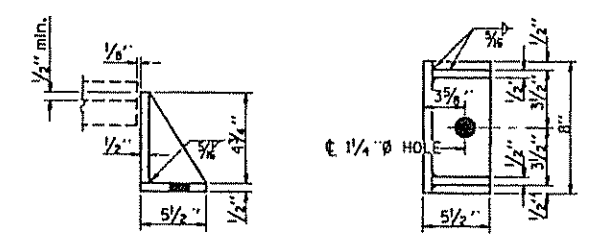

SIDE RETAINER

Equivalent rolled angle with stiffeners will be allowed in lieu of welded plates.

BILL OF MATERIAL		
Item	Unit	Total
Elastomeric Bearing Assembly (Type I)	Each	12
Furnishing & Erecting Structural Steel	lb.	2888
Jack & Remove Exist. Bearings	Each	12

BEARING REPLACEMENT AT NORTH ABUTMENTS
F.A.I. 55 OVER TURKEY CREEK
SECTION (57-3-1, 57-3, 57-3-2, 57-2) RS
MCLEAN COUNTY
STA. 608 + 35.40
S.N. 057-0169 & S.N. 057-0170

F.A.I. RTE.	SECTION	COUNTY	TOTAL SHEETS	SHEET NO.
55	•	MCLEAN	139	120
STA.		TO STA.		
FED. ROAD DIST. NO.	ILLINOIS	FED. AID PROJECT		
• (57-3-1, 57-3, 57-3-2, 57-2) RS				
SHEET 12 of 18				

GIRDER REACTIONS

RR	(K)	35.5
RT	(K)	40.6
Imp.	(K)	10.4
R (Total)	(K)	86.5

Notes: Diaphragm removal and replacement may be required to facilitate drilling holes. Cost shall be included in the cost of "Furnishing and Erecting Structural Steel".
 New steel extensions, side retainers, shim plates, connection bolts, and anchor bolts are included in "Furnishing and Erecting Structural Steel".
 See Sheet 17 of 18 for Anchor Bolt Installation.
 Prior to ordering any material, the Contractor shall verify in the field all bearing height and shim thickness dimensions.
 Min. Jack capacity = 45 Tons
 Two 1/8" shims of the dimensions of the bottom bearing plate shall be provided for each bearing in addition to all other plates or shims.

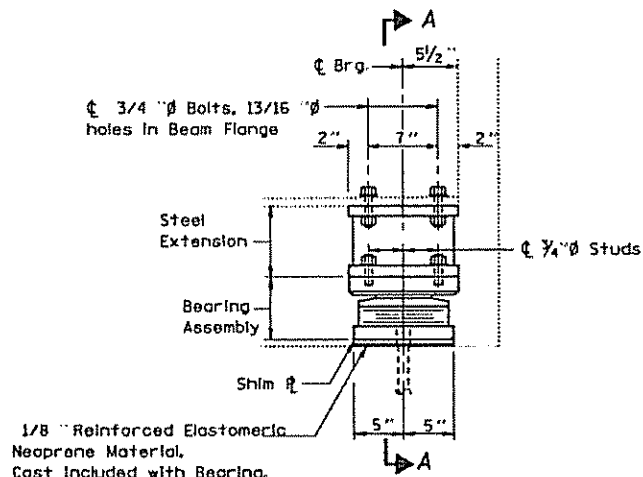

ELEVATION AT SOUTH ABUTMENT

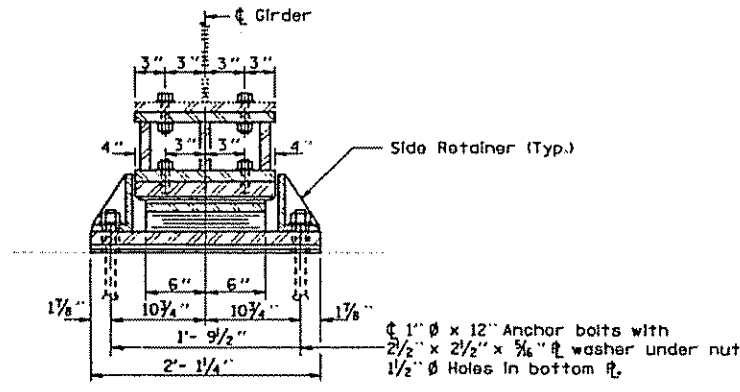

SECTION A-A

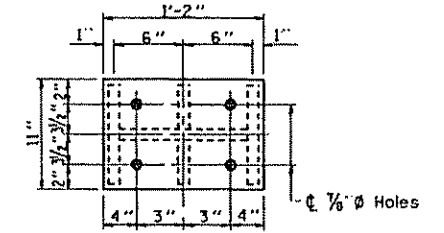

PLAN TOP AND BOTTOM PLATE

TYPE II TFE ELASTOMERIC EXP. BRG.

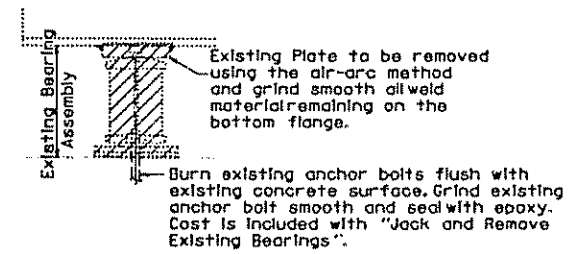

EXISTING BEARING REMOVAL DETAIL

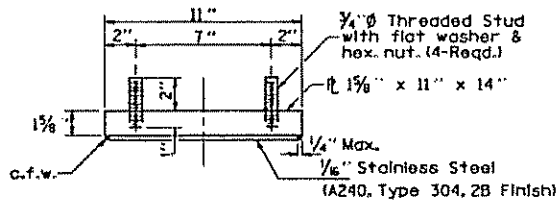

TOP BEARING ASSEMBLY

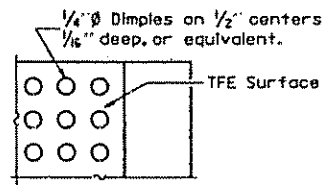

PLAN-TFE SURFACE

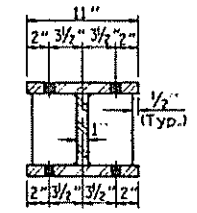

SECTION B-B

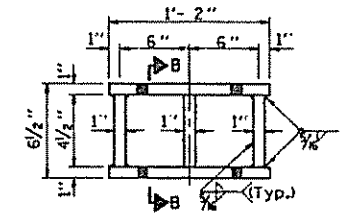

STEEL EXTENSION DETAIL

ADDITIONAL SOLID 1 PIECE SHIMS REQUIRED						
	Beam #1 (West)	2	3	4	5	6 (East)
S.N. 057-0169	1"	3/8"	—	—	—	1/2"
S.N. 057-0170	—	—	—	—	—	—

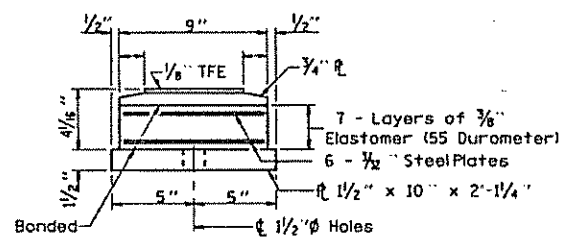

BOTTOM BEARING ASSEMBLY

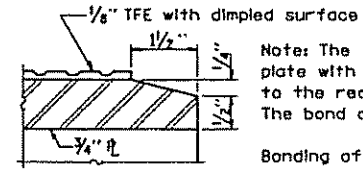

SECTION THRU TFE

Note: The 1/8" TFE sheet shall be bonded directly to the top steel plate with a two-component, medium viscosity epoxy resin, conforming to the requirements of the Federal Specification MMM-A-134, Type 1. The bond agent shall be applied on the full area of the contact surfaces.
 Bonding of 1/8" TFE sheet during vulcanizing process will be permitted provided the process and method of adjusting assembly height is approved by the Engineer.

BILL OF MATERIAL		
Item	Unit	Total
Elastomeric Bearing Assembly Type I	Each	12
Furnishing & Erecting Structural Steel	lb.	2274
Jack & Remove Exlet. Bearings	Each	12

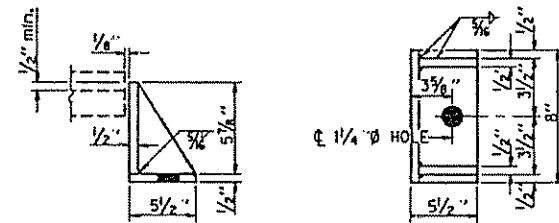

SIDE RETAINER

Equivalent rolled angle with stiffeners will be allowed in lieu of welded plates.

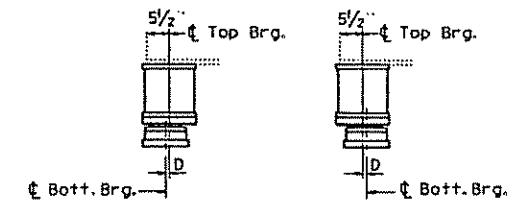

SETTING ANCHOR BOLTS AT EXP. BRG.

D=1/8" per each 100' of expansion for every 15° temp. change from the normal temp. of 50°F.

BEARING REPLACEMENT AT SOUTH ABUTMENTS
F.A.I. 55 OVER TURKEY CREEK
SECTION (57-3-1, 57-3, 57-3-2, 57-2) RS
MCLEAN COUNTY
STA. 608 + 35.40
S.N. 057-0169 & S.N. 057-0170

F.A.I. RYE	SECTION	COUNTY	TOTAL SHEETS	SHEET NO.
55	•	MCLEAN	139	121
STA.		TO STA.		
FED. ROAD DIST. NO.		ILLINOIS FED. AID PROJECT		
• 57-3-1, 57-3, 57-3-2, 57-2 RS				

SHEET 14 of 18

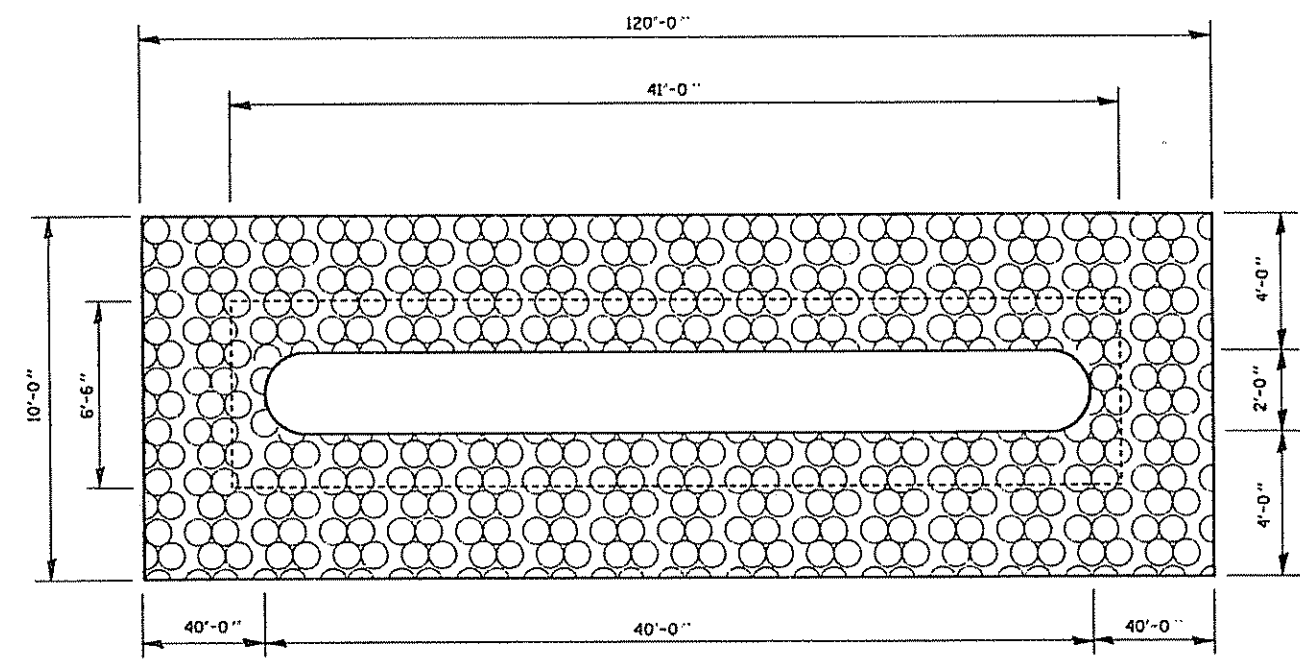

PIER CLOSEST TO CHANNEL

NOTE:
RIPRAP SHALL BE PLACED ONLY AROUND THE PIER CLOSEST TO THE CHANNEL.

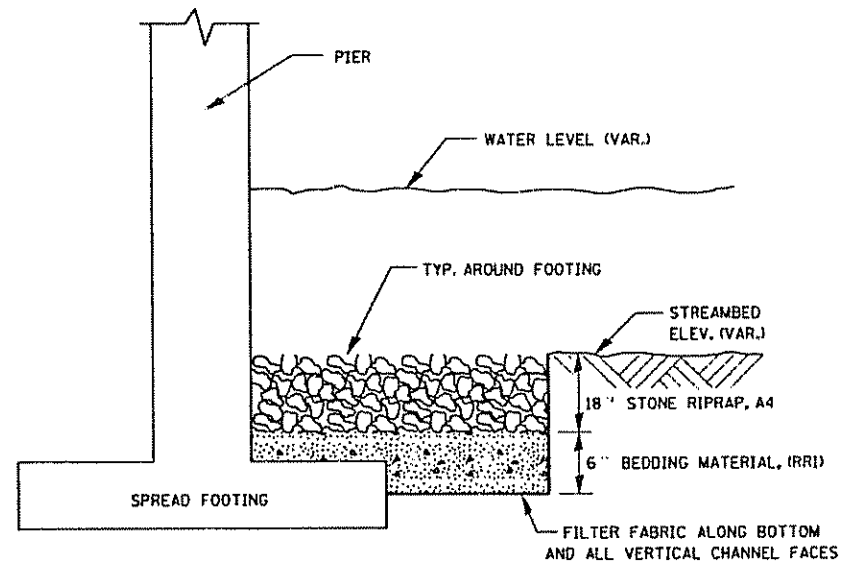

**TYPICAL SECTION FOR PIER.
RIPRAP CLASS A4**

NOTE: CHANNEL EXCAVATION SHALL NOT EXCEED BOTTOM OF FOOTING

STR. # 057-0169 & STR. # 057-0170

**RIPRAP AT PIERS
F.A.I. 55 OVER TURKEY CREEK
SECTION (57-3-1, 57-3, 57-3-2, 57-2) RS
MCLEAN COUNTY
STA. 608 + 35.40
S.N. 057-0169 & S.N. 057-0170**

DEC. 29, 1999
VED02100\DETAILS.DGN

F.A.I. SHEETS	SECTION #	COUNTY	TOTAL SHEETS	SHEET NO.
55	#	MCLEAN	139	120
STA.		TO STA.		
FED. RDW. DIST. NO.		ILLINOIS FED. AID PROJECT		
● (57-3-1, 57-3, 57-3-2, 57-2) RS				

SHEET 15 of 18

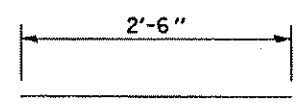
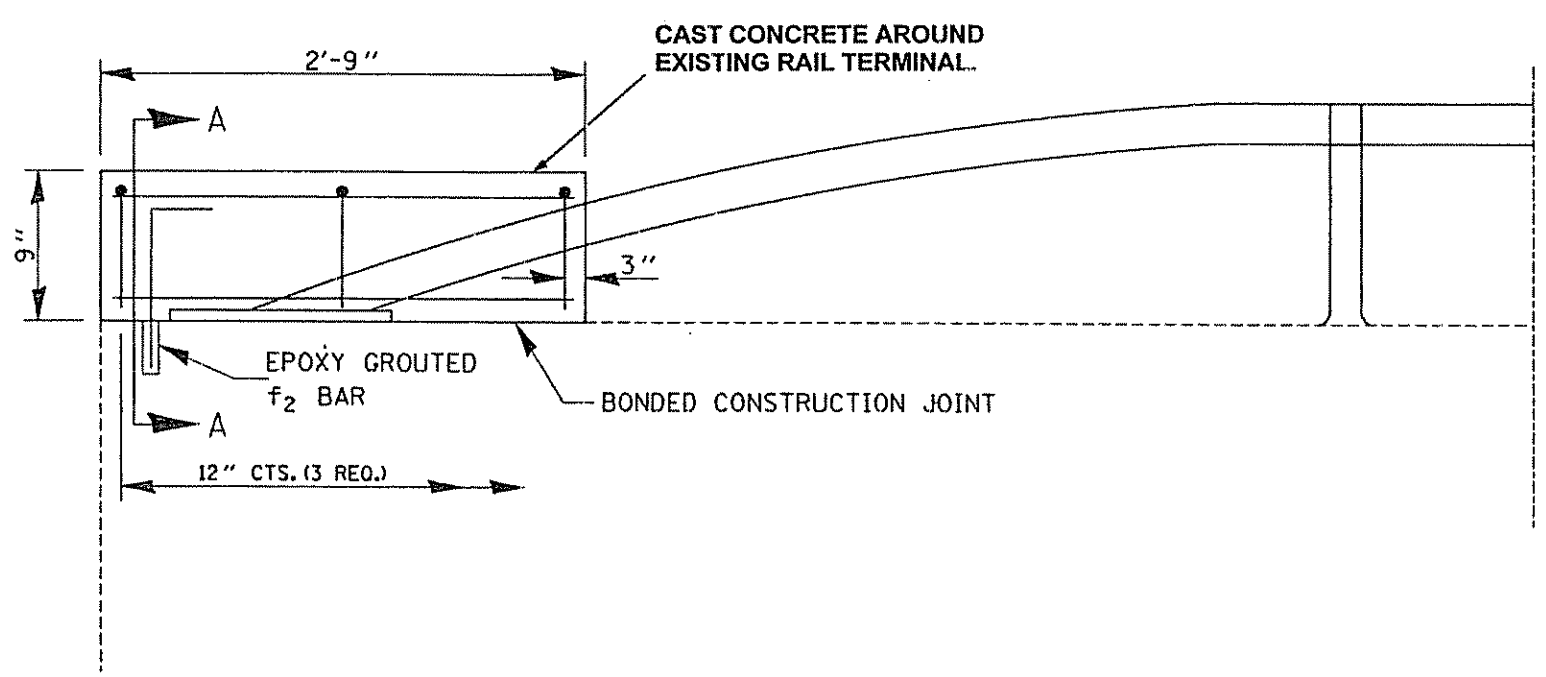

BAR f₃(E)

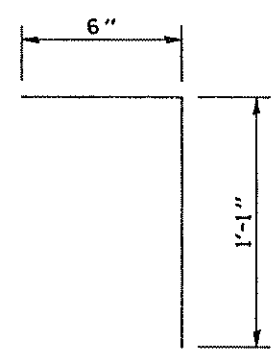

BAR f₂(E)

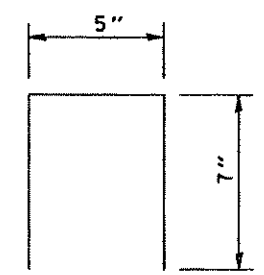

BAR f₁(E)

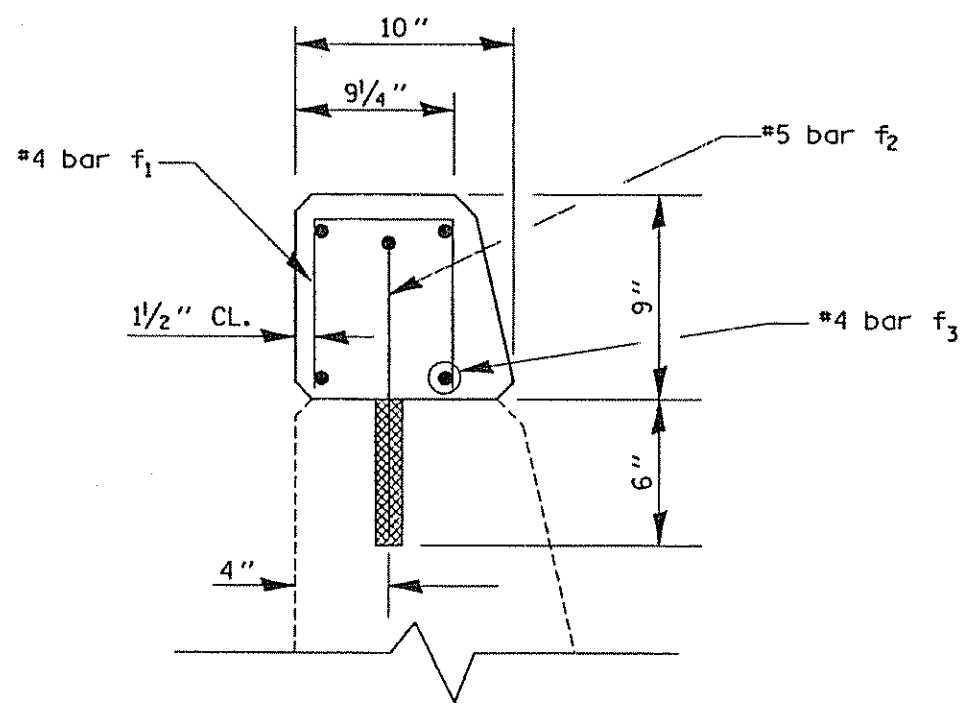

SECTION A-A

BILL OF MATERIAL PARAPET				
BAR	NO.	SIZE	LENGTH (FT.)	SHAPE
f ₁ (E)	3	#4	1' - 7"	□
f ₂ (E)	1	#5	1' - 7"	└
f ₃ (E)	4	#4	2' - 6"	—
CONC. SUPERSTRUCTURE			CU YD	0.06
REINFORCEMENT BARS, EPOXY COATED			POUND	12

REINFORCEMENT BARS DESIGNATED (E) SHALL BE EPOXY COATED

NOTE: QUANTITIES SHOWN ARE FOR EACH PARAPET EXTENSION

PARAPET DETAIL
F.A.I. 55 OVER TURKEY CREEK
SECTION (57-3-1, 57-3, 57-3-2, 57-2) RS
MCLEAN COUNTY
STA. 608 + 35.4
S.N. 057-0169 - NORTH END
S.N. 057-0170 - SOUTH END

STATE OF ILLINOIS
DEPARTMENT OF TRANSPORTATION

PROJECT NO.	SECTION	COMP.	SHEETS	SHEET	SHEET NO. 16 18 SHEETS
139	123				
<small>ILL. ROAD DIST., INC. P. ALLIANCE. PFD. AND PRODUCT.</small> <small>(57-3-1.57-3.57-3-2.57-2RS)</small>					

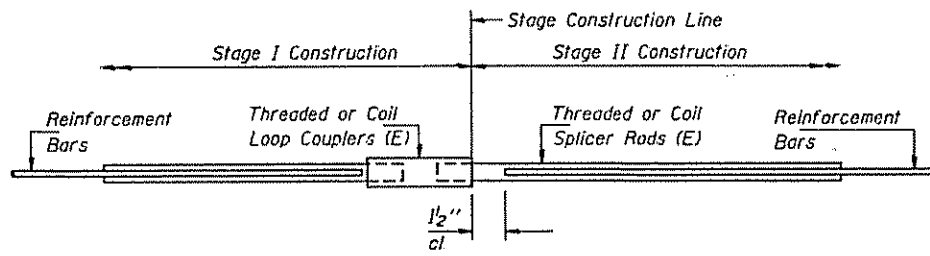

SPLICER DETAIL

Bar Size	No. Assemblies Required	Location
#6	32	Stage Construction Line S.N. 057-0169
#6	24	Stage Construction Line S.N. 057-0170
Total	56	

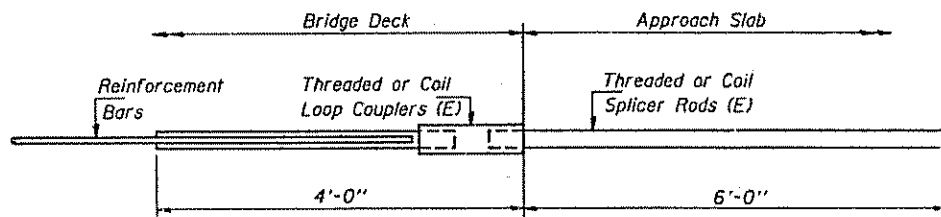

**INTEGRAL ABUTMENT
BAR SPLICER ASSEMBLY DETAIL
FOR #5 BAR**

Min. Capacity = 23.0 kips - tension
Min. Pull-out Strength = 9.2 kips - tension
No. Required =

The diameter of this part is the same as the diameter of the bar spliced.

The diameter of this part is equal or larger than the diameter of bar spliced.

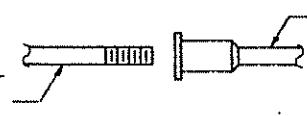

ROLLED THREAD DOWEL BAR



ONE PIECE

Wire Connector



WELDED SECTIONS

BAR SPLICER ASSEMBLY ALTERNATIVES

** Heavy Hex Nuts conforming to ASTM A 563, Grade C, D or DH may be used.

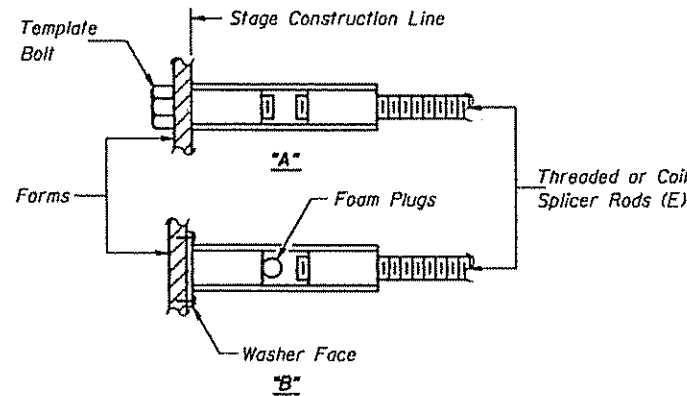

INSTALLATION AND SETTING METHODS

"A" : Set bar splicer assembly by means of a template bolt.

"B" : Set bar splicer assembly by nailing to wood forms or cementing to steel forms.

(E) : Indicates epoxy coating.

NOTES

Bar splicer assemblies shall be of an approved type and shall develop in tension at least 125 percent of the yield strength of the lapped reinforcement bars.

Splicer rods shall be of minimum 60 ksi yield strength, threaded or coiled full length.

All reinforcement bars shall be lapped and tied to the splicer rods or dowel bars.

Bar splicer assemblies shall be epoxy coated according to the requirements for reinforcement bars.

Other systems of similar design may be submitted to the Engineer for approval. Approval shall be based on certified test results from an approved testing laboratory that the proposed bar splicer assembly satisfies the following requirements:

- Minimum Capacity = $1.25 \times f_y \times A_l$
(Tension in kips)
- Minimum Pull-out Strength = $1.25 \times f_{s_{allow}} \times A_l$
(Tension in kips)

Where f_y = Yield strength of lapped reinforcement bars in ksi.

$f_{s_{allow}}$ = Allowable tensile stress in lapped reinforcement bars in ksi (Service Load)

A_l = Tensile stress area of lapped reinforcement bars.

* = 28 day concrete

Bar Size to be Spliced	Splicer Rod or Dowel Bar Length	Strength Requirements	
		Min. Capacity kips - tension	Min. Pull-Out Strength kips - tension
#5	2'-0"	23.0	9.2
#6	2'-7"	33.1	13.3
#7	3'-5"	45.1	18.0
#8	4'-6"	58.9	23.6

Bar splicer assemblies shall be according to Section 508 of the Standard Specifications, except as noted. The furnishing and installation of bar splicer assemblies will be measured and paid for at the contract unit price each for "BAR SPLICERS."

DESIGNED	
CHECKED	
DRAWN	
CHECKED	

EXAMINED	20
PASSED	ENGINEER OF BRIDGE DESIGN
	ENGINEER OF BRIDGES AND STRUCTURES

F.A.I. RTE.	SECTION	COUNTY	TOTAL SHEETS	SHEET NO.
55	•	MCLEAN	139	124

STA. TO STA.
 FED. ROAD DIST. NO. ILLINOIS FED. AID PROJECT
 • (57-3-1, 57-3, 57-3-2, 57-2) RS

SHEET 17 of 18

The Illinois Coil-Lock Anchor Bolt is a proprietary item which is the property of the Illinois Department of Transportation. Use, reproduction or disclosure without express written permission is prohibited and protected under Federal copyright laws. The production and the fabrication of this bolt for use on highway projects in the State of Illinois shall be permitted and there shall be no incurred charges or fees to the manufacturer or the fabricator for producing or fabricating this bolt.

D	E	H	K	"d"
1"	1 1/8"	1 1/2"	1 3/4"	1/4"
1 1/4"	1 3/8"	1 3/4"	2"	3/8"
1 1/2"	1 5/8"	1 3/4"	2 1/8"	1/2"
2"	2 1/8"	1 3/4"	2 7/8"	1/2"
2 1/2"	2 3/8"	2 1/4"	3 3/8"	1"

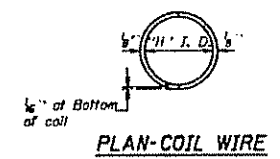
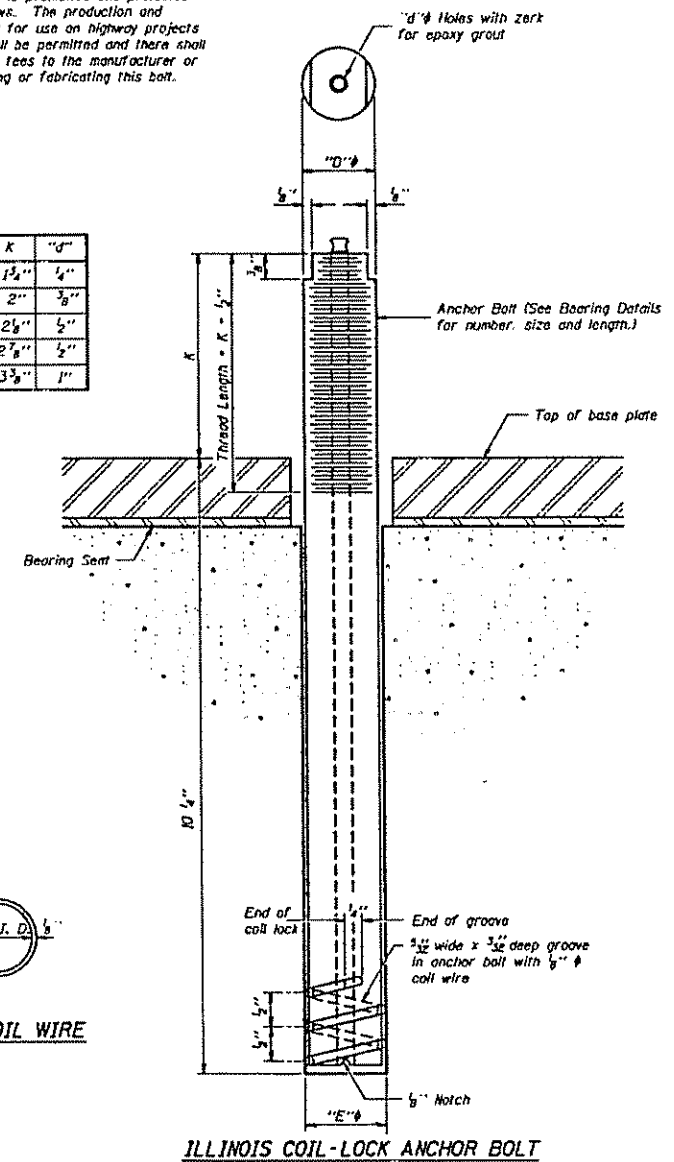

MATERIALS FOR ILLINOIS COIL-LOCK ANCHOR BOLT

The anchor bolt shall be fabricated from cold drawn or hot finished seamless carbon steel mechanical tubing conforming to ASTM A 519, Grade 1026. CW and supplied with hexagonal nuts and cut washers.
 The coil wire shall be made of any suitable soft steel wire.
 The finished anchor bolt shall be cleaned of rust and other foreign materials and wrapped or packaged to prevent contamination until they are installed.
 The epoxy grout shall be a two-component, epoxy resin bonding system conforming to ASTM C 881, Type I, Grade I and of a Class suitable for the temperature at installation.

INSTALLATION PROCEDURE for the ILLINOIS COIL-LOCK ANCHOR BOLT

1. With the coil wire in place, the bolt shall be inserted into the hole and turned clockwise to a snug fit in the hole. Nut and washer shall be placed on the bolt. The nut shall be tensioned until the steel base plates are held securely to the concrete bearing seat.
2. Epoxy grout shall be pumped through the zerk fitting with a pressure gun. Pumping shall continue until the epoxy overflows the hole around the bolt shank. After pumping is discontinued, excess epoxy shall be immediately wiped off.

ALTERNATE ANCHOR BOLTS

The Contractor may use, at his option, the capsule or the adhesive cartridge type anchor rods that have been previously tested and given a prior approval by the Department. The Contractor shall install these anchor rods in pre-drilled holes according to the manufacturer's recommendations and procedures.
 The capsule or the adhesive cartridge type anchor rods shall be a two part system composed of:
 1. A threaded rod stud with nut and washer of the type specified.
 2. A sealed glass capsule or a sealed glass adhesive cartridge containing premeasured amounts of the adhesive chemical.

Location	Type
Abutment	A 307

ASTM F 1554 Grade 105, ASTM A 449 and AASHTO M 314 Grade 105 anchor bolts may be substituted for the anchor bolts shown above.

GENERAL NOTES

Holes in the masonry for anchor bolts shall be drilled through the base plates to the diameter and depth shown or according to the manufacturer's recommendation after beams or girders have been erected and adjusted.
 Prior to setting the bolts, the holes shall be dry and all dust and loose particles shall be removed by the use of compressed air or vacuuming.
 The anchor bolts, furnished and installed including the epoxy grout or capsules shall not be paid for separately but shall be included in the unit bid price for "Furnishing and Erecting Structural Steel".

**ANCHOR BOLT DETAILS FOR BEARINGS
 F.A.I. 55 OVER TURKEY CREEK
 SECTION (57-3-1, 57-3, 57-3-2, 57-2) RS
 MCLEAN COUNTY
 STA. 608 + 35.40
 S.N. 057-0169 & S.N. 057-0170**

ABB-1 4-30-99

DEC. 29, 1999
 YED02100VETA/LS.DGN

F.A.I. RTE.	SECTION	COUNTY	TOTAL SHEETS	SHEET NO.
55	0	MCLEAN	139	126
STA.		TO STA.		
FED. ROAD DIST. NO.		ILLINOIS FED. AID PROJECT		
• (57-3-1, 57-3, 57-3-2, 57-2) RS				

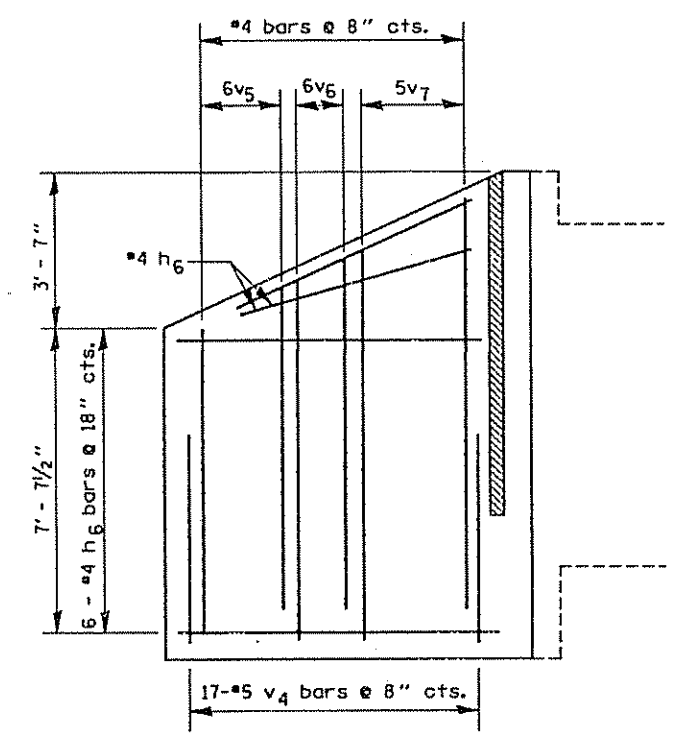

ELEVATION

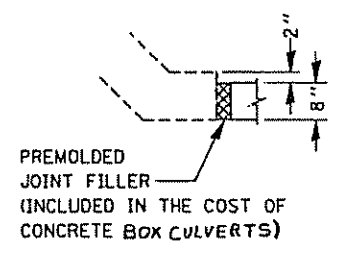

CORNER DETAIL

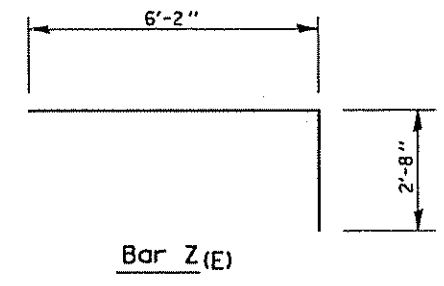

Bar Z(E)

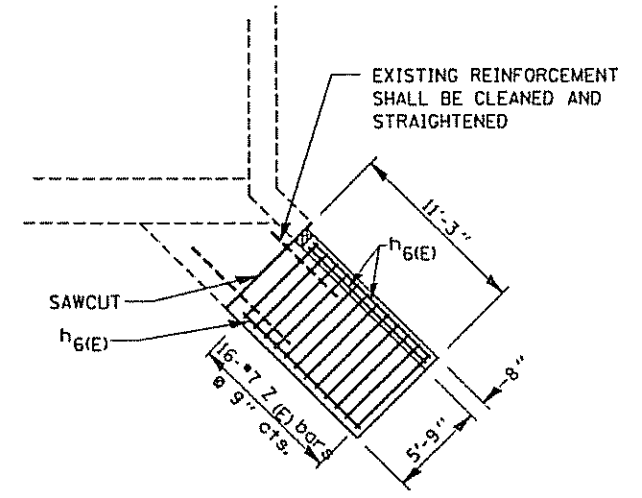

PLAN

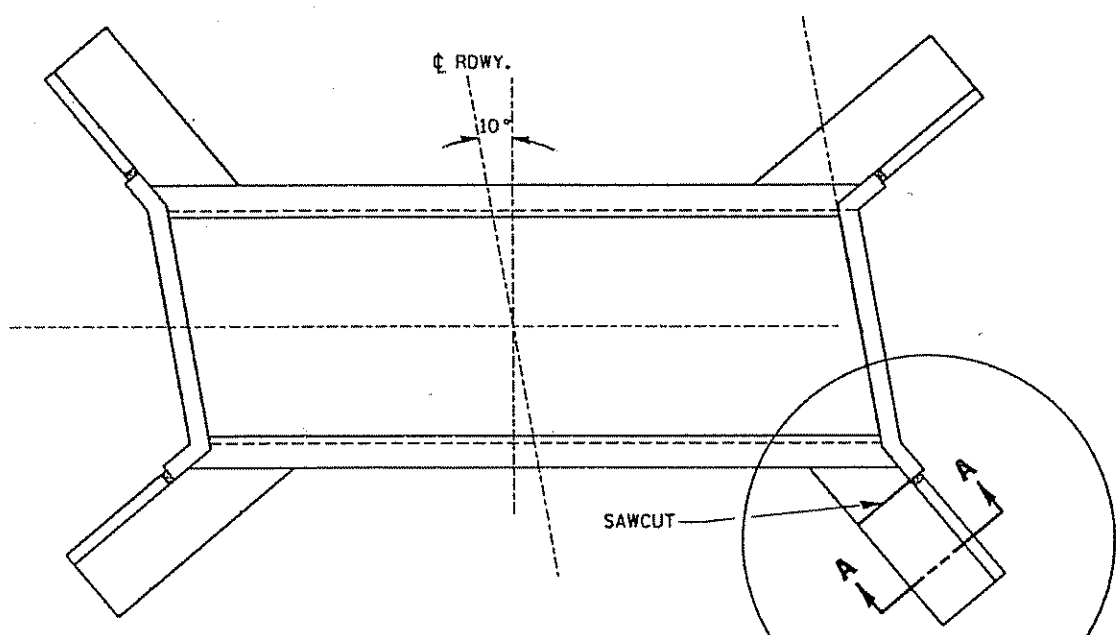

FULL PLAN

REMOVE & REPLACE FALLEN WINGWALL

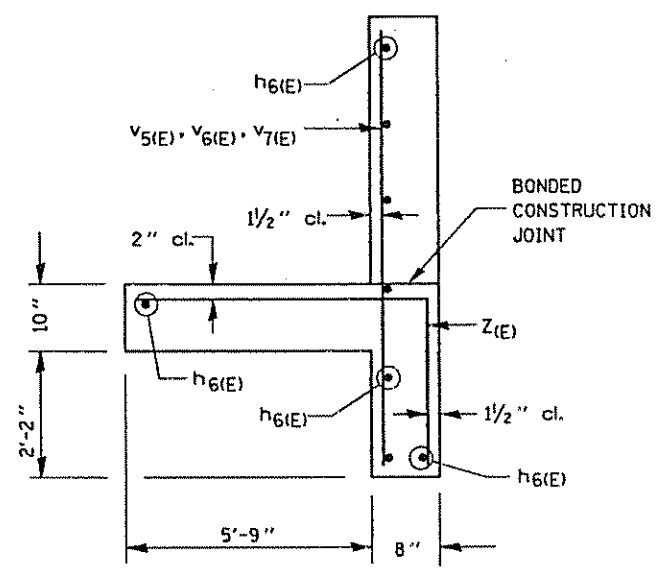

SECTION A-A

NOTE: CARE SHOULD BE TAKEN TO NOT DISTURB THE EXISTING GROUND LINE. VOIDS SHALL BE FILLED AND COMPACTED PRIOR TO PLACEMENT OF CONCRETE FOOTING. THIS WORK WILL BE INCLUDED IN THE COST OF STRUCTURE EXCAVATION.

SAW CUT SHALL BE INCLUDED IN THE COST OF CONCRETE REMOVAL.

BILL OF MATERIALS SN 057-0801				
BAR	NO.	SIZE	LENGTH	SHAPE
h6(E)	8	#4	10' - 11"	—
v4(E)	17	#5	5' - 3"	—
v5(E)	6	#4	7' - 6"	—
v6(E)	6	#4	8' - 8"	—
v7(E)	5	#4	9' - 10"	—
z(E)	16	#7	8' - 10"	┌
CONCRETE REMOVAL			CU YD	5
CONC. BOX CULVERTS			CU YD	5
STRUCTURE EXCAVATION			CU YD	38
BAR SPLICERS			EACH	10
REINFORCEMENT BARS, EPOXY COATED			POUND	551

REINFORCEMENT BARS DESIGNATED (E) SHALL BE EPOXY COATED

WINGWALL REPLACEMENT DETAIL
SECTION (57-3-1, 57-3, 57-3-2, 57-2) RS
MCLEAN COUNTY
STA. 571 + 67
S.N. 057-0801

P.A. & P.C.	SECTION	COUNTY	YEAR BUILT	SHEET NO.
55	8	McLEAN	139	127
STA.		TO STA.		
FED. ROAD DIST. NO.	ALIGNED	FED. ROAD PROJECT		
● 157-3-1.57-3.57-3-2.57-21RS				

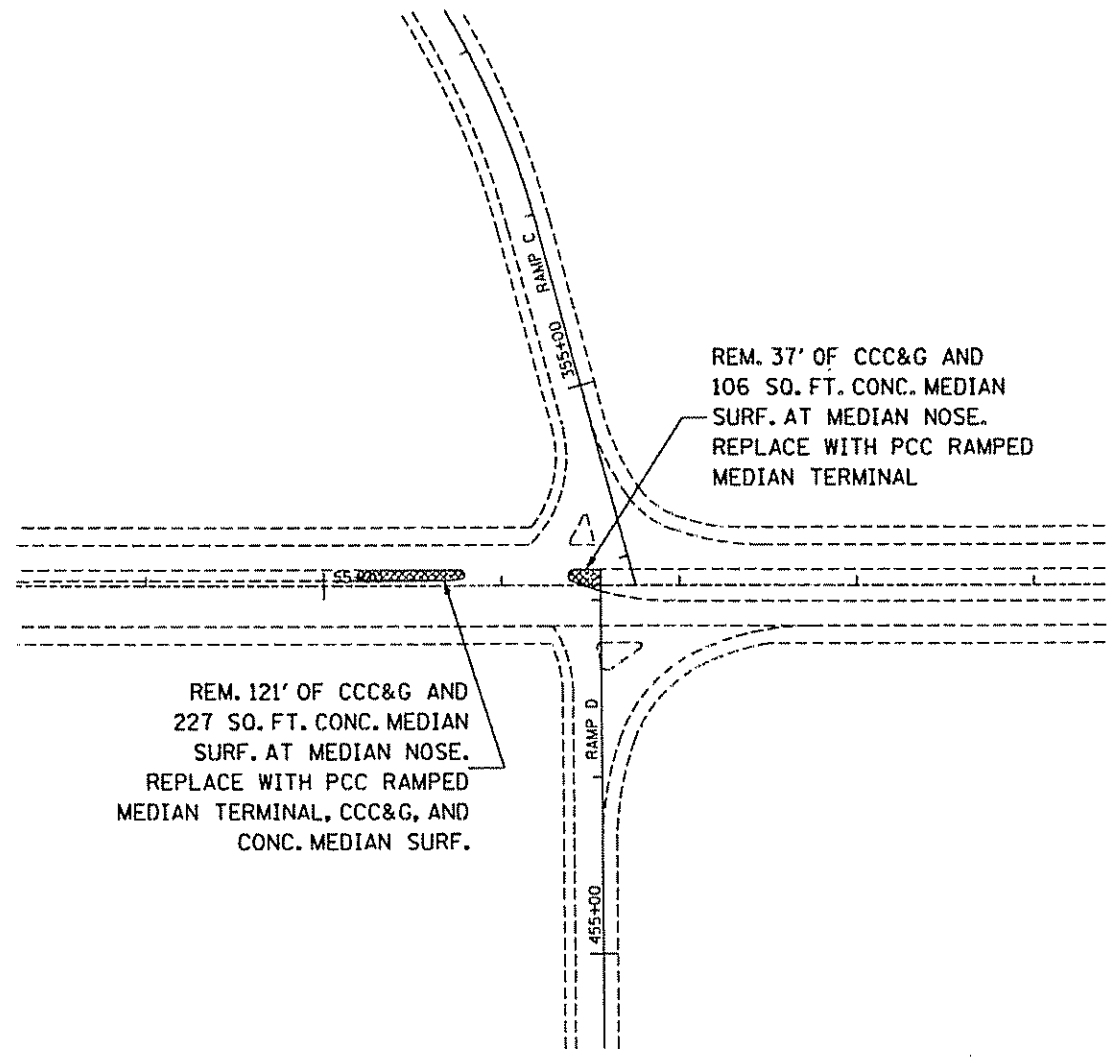
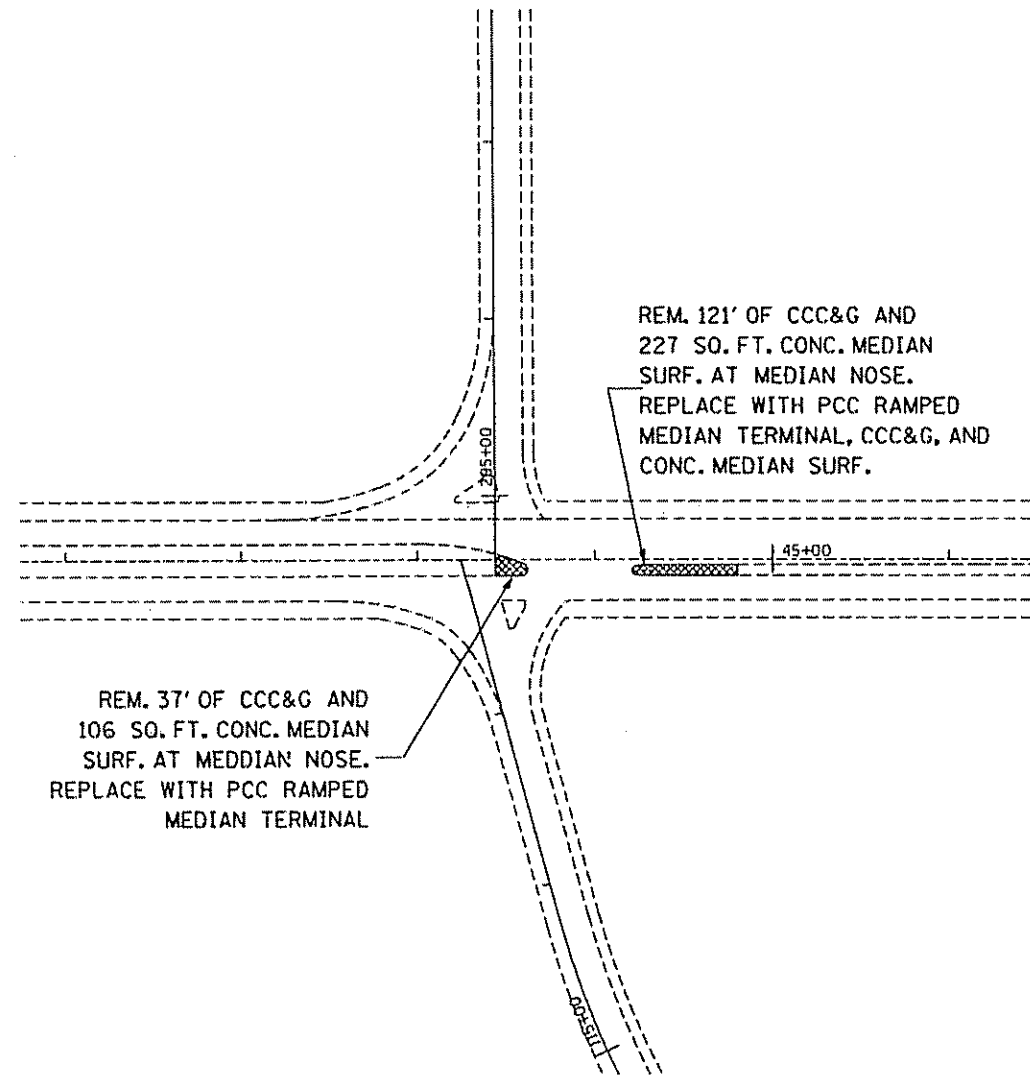

JAN. 11, 2000
 \ED02100\SHEETS.DGN

**C.H. 29
 MEDIAN
 REMOVAL DETAIL**

S.N. 057-0162

PLAN NO.	SECTION	COUNTY	TOTAL SHEETS	SHEET NO.
55	4	MGLEAN	139	128
STA.	TO STA.			
POLYMER BLENDED		SLURRY	POLYMER PROJECT	
*157-3-1,57-3,57-3-2,57-21RS				

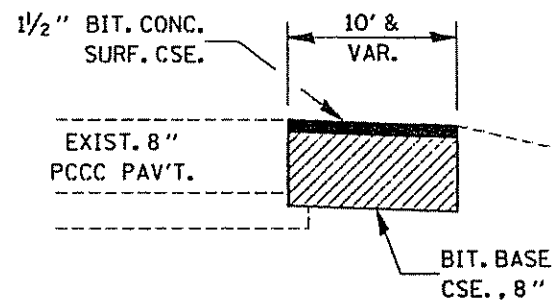
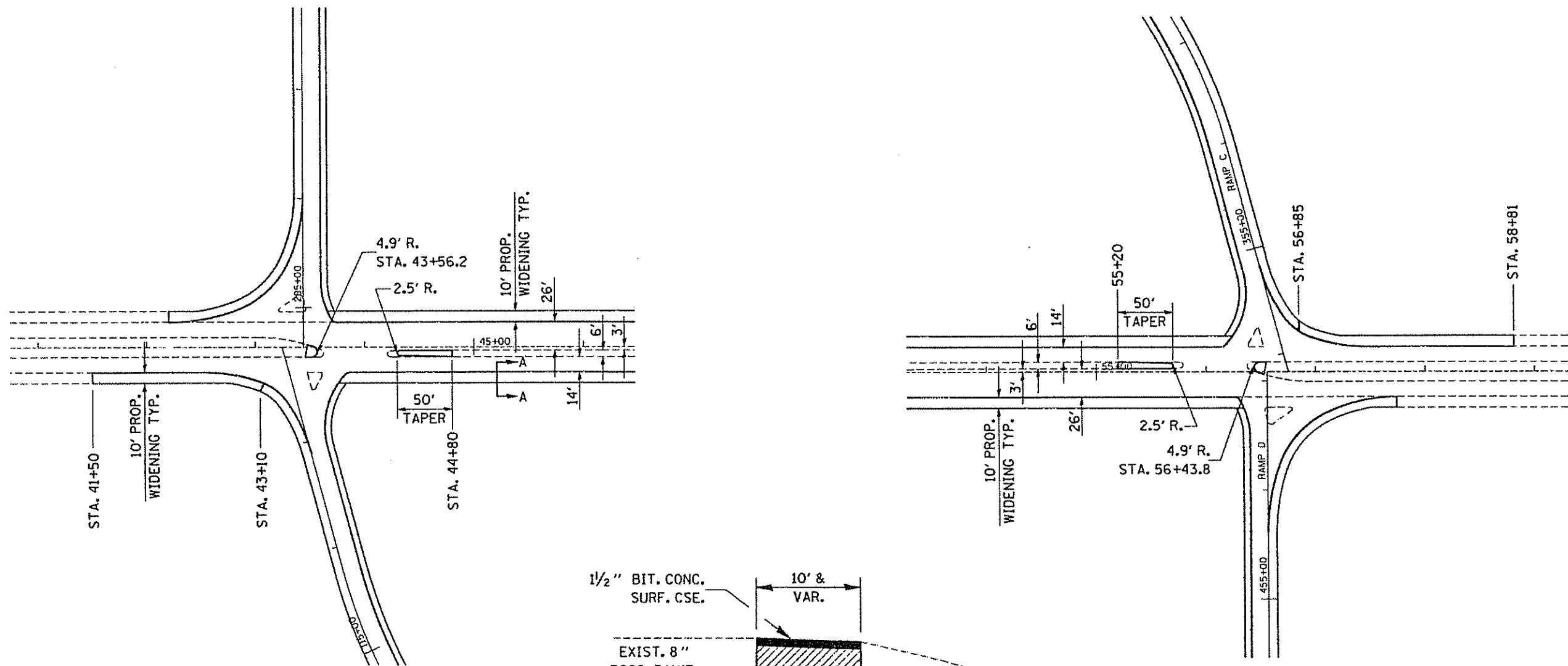

SEC. A-A
WIDENING DETAIL

CH 29 AT S.N. 057-0162

NOTE:
ANY ADDITIONAL EXCAVATION REQUIRED AFTER
PAVED SHOULDER REMOVAL WILL BE INCLUDED
IN THE COST OF BIT. BASE CSE., 8"

C.H. 29
INTERCHANGE
GEOMETRICS DETAIL

S.N. 057-0162

F.A.I. RTE.	SECTION	COUNTY	TOTAL SHEETS	SHEET NO.
55	•	MCLEAN	139	129
STA.	TO STA.			
FED. ROAD DIST. NO.	ILLINOIS	FED. AID PROJECT		
• 157-3-1, 57-3, 57-3-2, 57-21 RS				

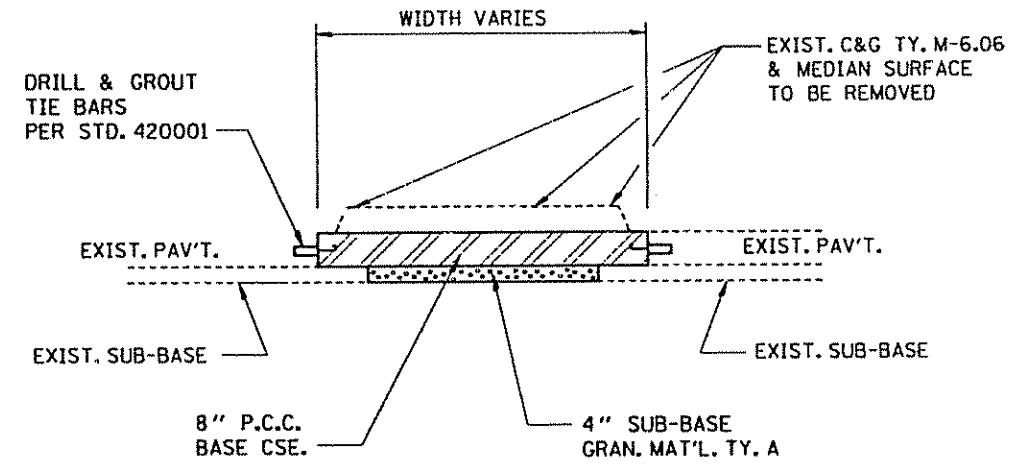

DETAIL AT MEDIAN NOSE REMOVALS

APPROACHES TO STR. 057-0162
N.T.S.

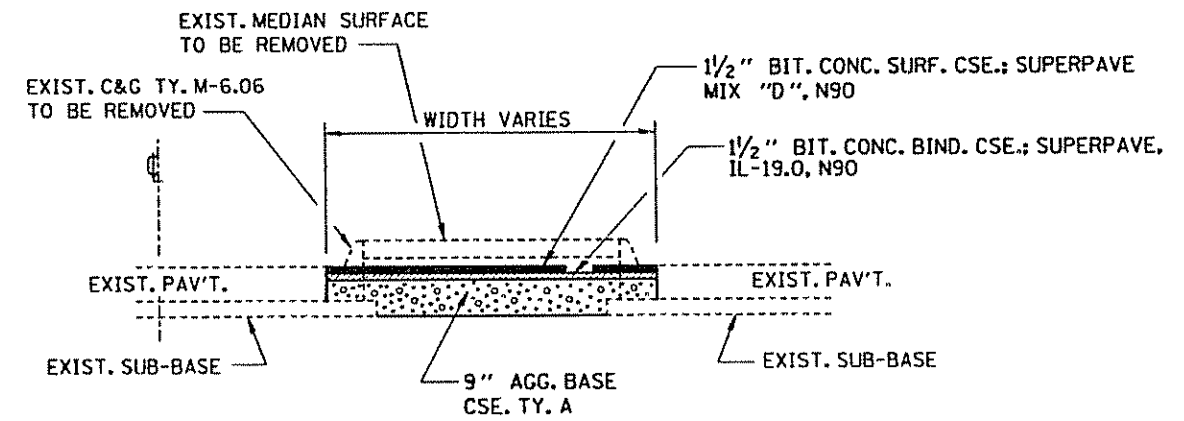

DETAIL AT TEMPORARY MEDIAN REMOVAL

APPROACHES TO STR. 057-0162
N.T.S.

NOTE: TEMP. SURF. & BIND. CSE. SHALL BE REM. AFTER STAGE CONSTRUCTION. THIS WORK WILL BE PAID FOR AT THE CONTRACT UNIT PRICE FOR SQ. YD. OF PAVEMENT REMOVAL. ADDITIONAL AGG. BASE CSE., TY. A SHALL THEN BE ADDED BEFORE REPLACING THE CONC. MEDIAN SURFACE.

**C.H. 29
DETAILS**

S.N. 057-0162

JAN. 11, 2000
VED02100.DETA/ILS.DGN

F.A.I. RTE.	SECTION	COUNTY	TOTAL SHEETS	SHEET NO.
55	*	MCLEAN	139	130
STA.		TO STA.		
FED. ROAD DIST. NO.		ILLINOIS FED. AID PROJECT		
* 57-3-1, 57-3, 57-3-2, 57-21 RS				

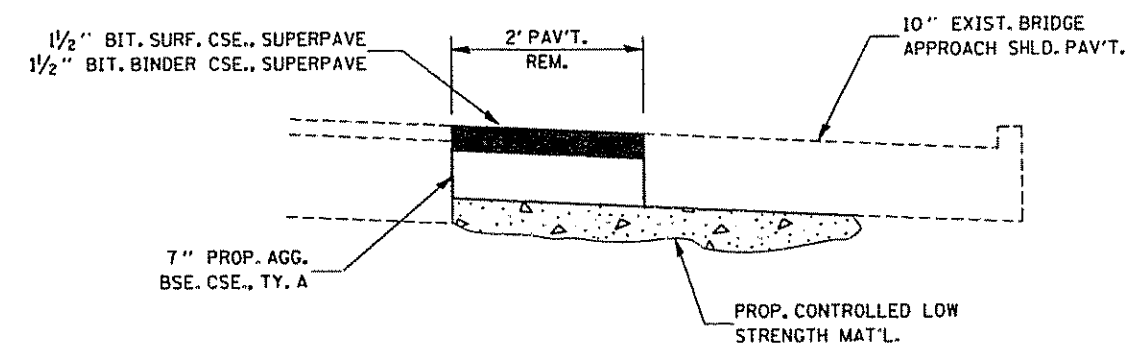
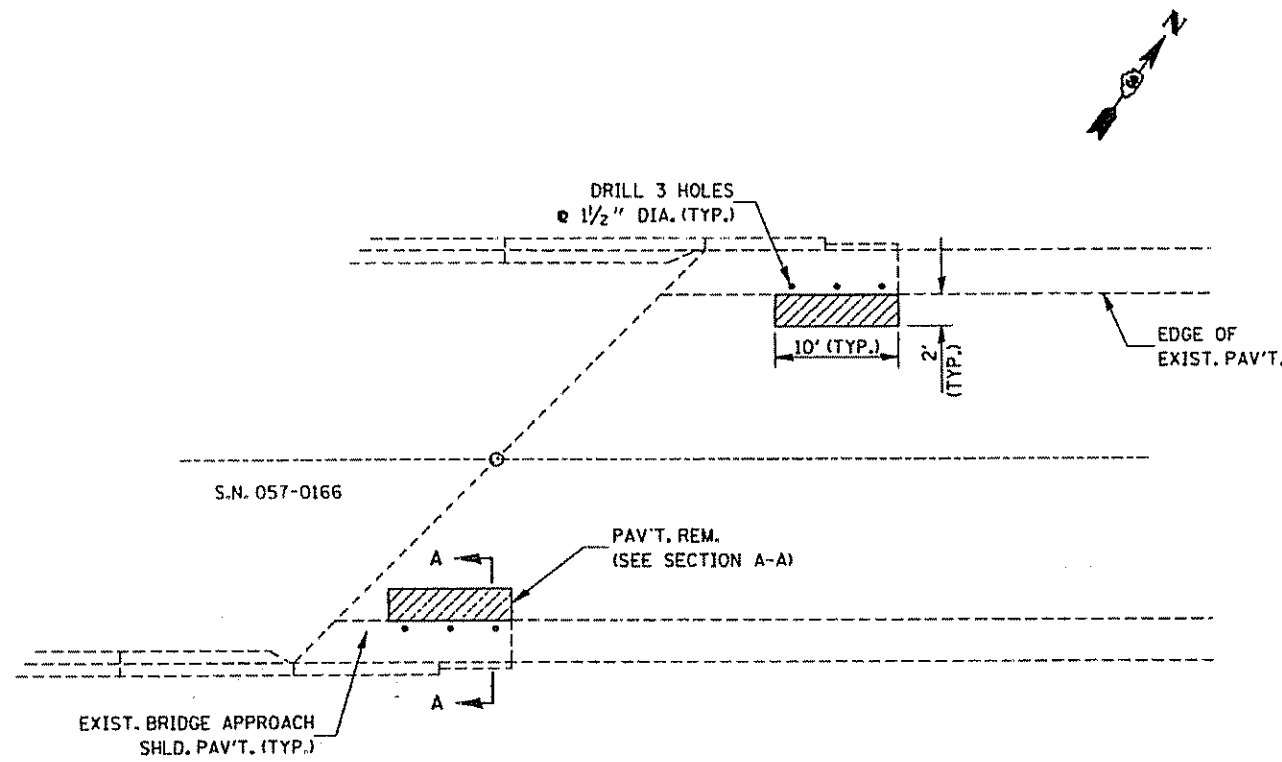

SECTION A-A

PAVEMENT REPAIR S.N. 057-0166					
LOCATION	PAV'T REM	CONTROLLED LOW STR. MATERIAL	AGG. BASE CSE TYPE A	BIT. CONC. SURF. CSE. SUPERPAVE	BIT. CONC. BINDER CSE. SUPERPAVE
	SO. YD.	CU. YD.	TON	TON	TON
NE QUADRANT	2.2	1	0.9	0.2	0.2
SE QUADRANT	2.2	1	0.9	0.2	0.2
TOTAL	4.4	2	1.8	0.4	0.4

- NOTES:
- CONTROLLED LOW STRENGTH MATERIAL SHALL BE PUMPED INTO VOID AREAS TO AN ELEVATION EVEN WITH THE BOTTOM OF BRIDGE APPROACH SHOULDER PAVEMENT.
 - THREE 1/2" DIAMETER HOLES SHALL BE DRILLED INTO EACH BRIDGE APPROACH SHOULDER TO ALLOW THE ESCAPE OF AIR. THIS WORK SHALL BE INCLUDED IN THE COST OF CONTROLLED LOW STRENGTH MATERIAL.

JAN. 11, 2005
 \ED021001.DETAILS.DGN

F.A.I. RTE.	SECTION	COUNTY	TOTAL SHEETS	SHEET NO.
55	■	MCLEAN	739	131
STA.	TO STA.			
FED. ROAD DIST. NO.	ILLINOIS	FED. AID PROJECT		
■ 157-3-1, 57-3, 57-3-2, 57-21 RS				

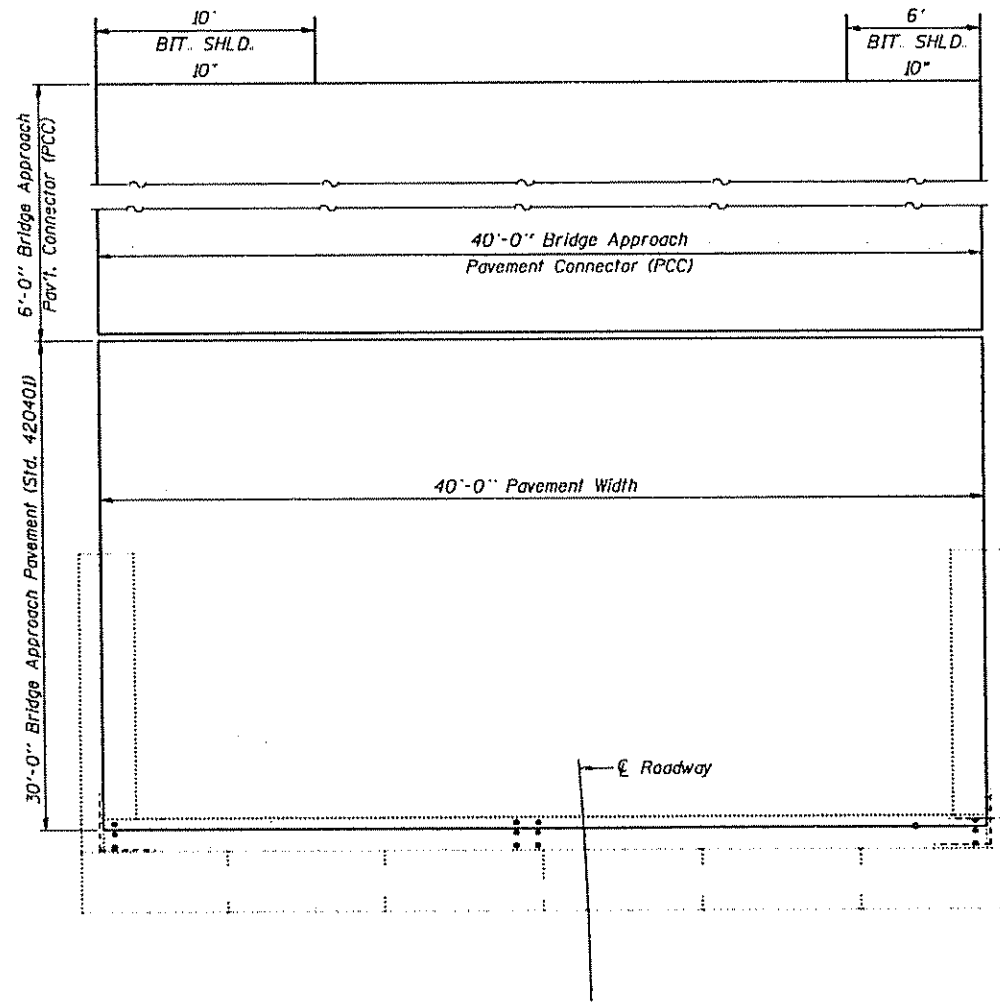

PROPOSED APPROACH SLAB

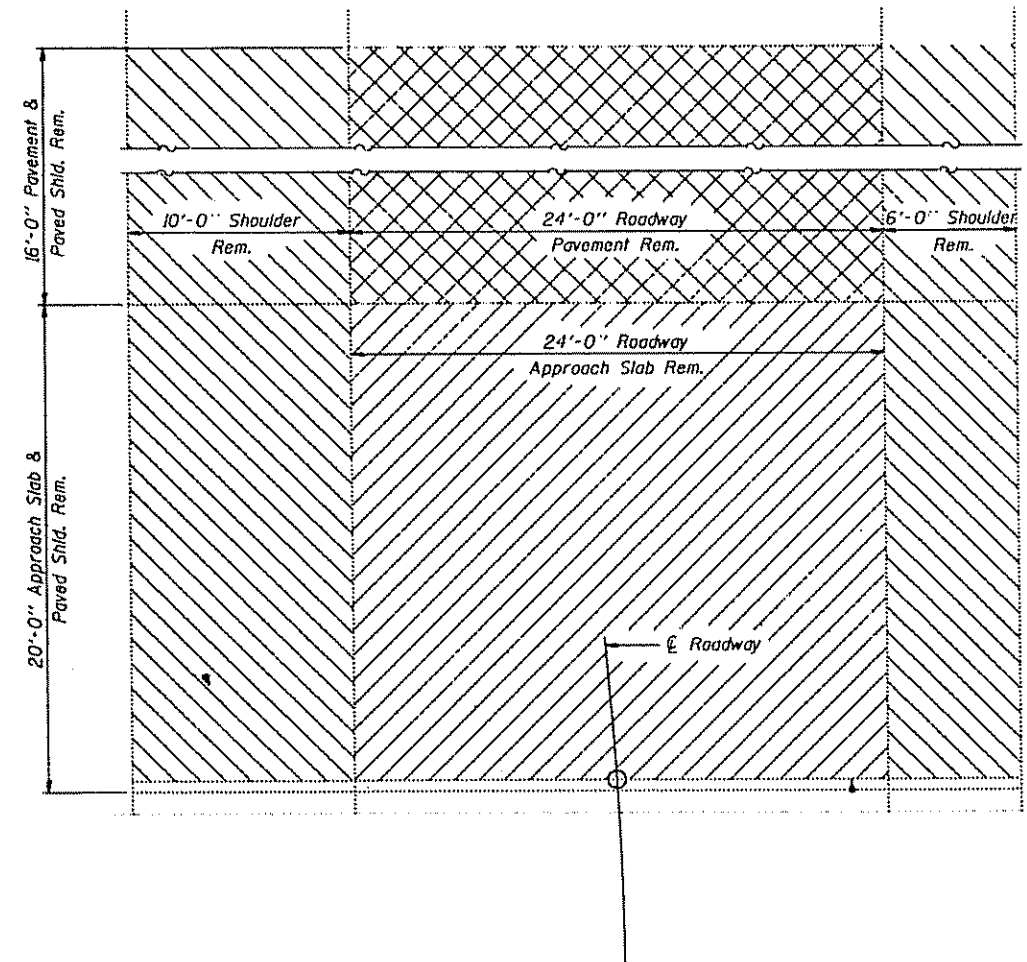

APPROACH SLAB REMOVAL PLAN

JAN. 11, 2000
VED02100\DETA\15.DGN

S.N. 057-0167 & S.N. 057-0168

**APPROACH SLAB
REPLACEMENT DETAIL**

TYPICAL APPLICATIONS FOR TRAFFIC COUNTER USING TERMINAL FACILITY

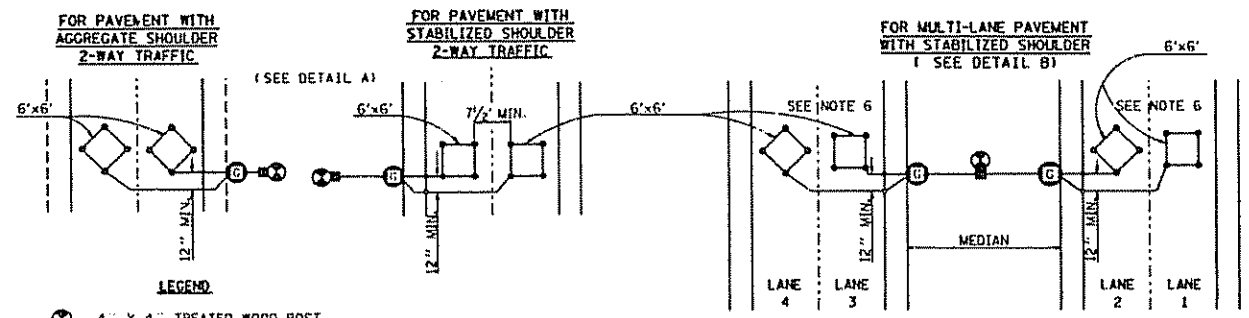

- LEGEND**
- ⊗ 4" x 4" TREATED WOOD POST
 - TERMINAL FACILITY
 - ⊕ GULFBOX JUNCTION
 - INDICATES 4" HOLE DRILLED AT PAVEMENT JOINT
 - INDICATES 1/4" HOLE DRILLED AT DETECTOR LOOP CORNER

GENERAL NOTES

1. EACH DETECTOR LOOP USED SHALL BE WIRED INDEPENDENTLY AT THE GULFBOX.
2. A SINGLE MULTIPLE PAIR CABLE SHALL BE WIRED FROM THE GULFBOX TO THE TERMINAL FACILITY. THE NUMBER OF PAIRS IN THE CABLE SHALL BE EQUAL TO THE NUMBER OF DETECTOR LOOPS PLUS A MINIMUM OF ONE PAIR TO BE USED AS A SPARE.
3. SQUARE SHAPED LOOPS SHALL HAVE A MINIMUM SEPARATION 7 1/2" BETWEEN INSIDE EDGES OF THE DETECTOR LOOPS.
4. EACH 6' X 6' DETECTOR LOOP SHALL HAVE A MINIMUM OF 4 TURNS OF CABLE OR AS DIRECTED BY THE ENGINEER.
5. DETECTOR LOOPS SHALL BE ORIENTED AS SQUARES ONLY. DIAMOND SHAPES WILL NOT BE ALLOWED.
6. GULFBOX JUNCTIONS SHALL BE LOCATED OUTSIDE THE AGGREGATE OR STABILIZED SHOULDER LIMITS WITH THE TOP OF GULFBOX JUNCTIONS LEVEL WITH GROUNDLINE AS DIRECTED BY THE ENGINEER.
7. DETECTOR LOOPS SHALL BE PLACED IN THE TOP LIFT OF BITUMINOUS CONCRETE BINDER COURSE.

SCHEDULE OF QUANTITIES			
CODE NO.	ITEM	QUANTITY	UNIT
B1012400	CONDUIT IN TRENCH, 1/4" DIA., PVC	114	FOOT
B1500100	GULFBOX JUNCTION	2	EACH
B1500105	GULFBOX JUNCTION REMOVAL	2	EACH
B2401200	ELECTRIC CABLE IN CONDUIT, SIGNAL NO.14, 1C	48	FOOT
B2401510	ELECTRIC CABLE IN CONDUIT, LEAD-IN, NO.18, 3 PAIR	92	FOOT
B4700400	DETECTOR LOOP, SPECIAL	134	FOOT
B6301000	TERMINAL FACILITY	1	EACH
B6800100	TRENCH AND BACKFILL FOR ELECTRICAL WORK	72	FOOT
B6800105	TRENCH AND BACKFILL FOR ELECTRICAL WORK, SPECIAL	32	FOOT
*300D936	TERMINAL FACILITY REMOVAL	1	EACH

F.A. RTE.	SECTION	COUNTY	TOTAL SHEETS	SHEET NO.
55	*	MCLEAN	139	132
STA.		TO STA.		
FED. ROAD DIST. NO.		ILLINOIS	FED. AID PROJECT	
		*(57-3-1.57-3.57-3-2.57-2IRS		

DETAIL A
TERMINAL FACILITY DETAIL

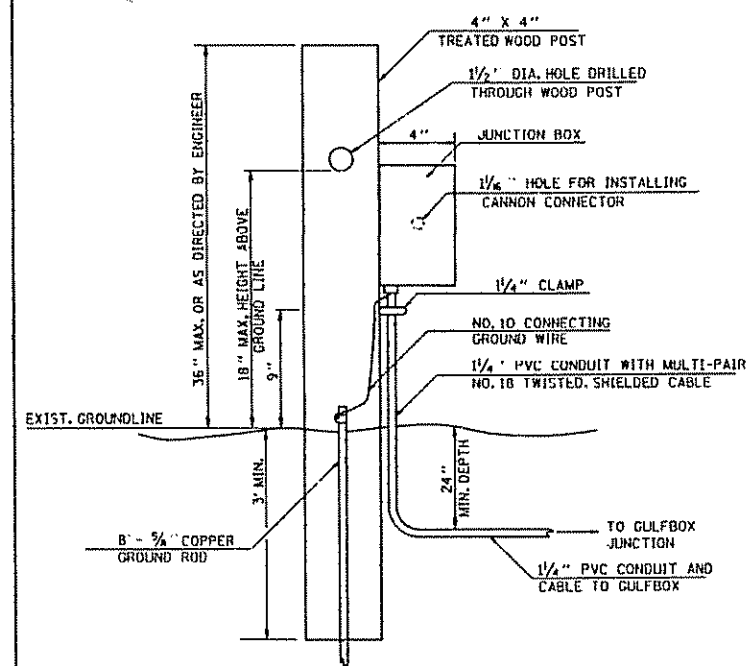

NOTES FOR TERMINAL FACILITY

1. GROUND ROD SHALL BE CONNECTED TO THE JUNCTION BOX WITH NO. 10 AWG COPPER WIRE AS SHOWN IN THE JUNCTION BOX DETAIL.
2. POST FOR EXISTING TERMINAL FACILITY SHALL BE USED FOR THE PROPOSED TERMINAL FACILITY.

DETAIL B
TERMINAL FACILITY DETAIL

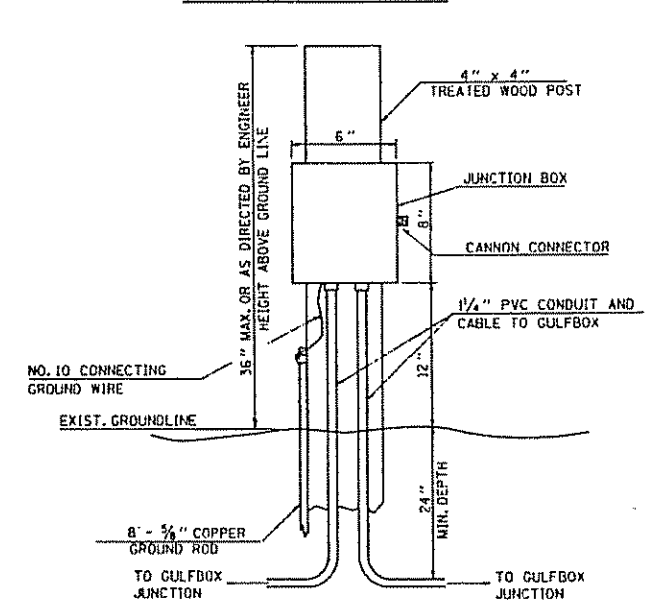

LOCATIONS

JUNCTION BOX DETAIL
FOR DETAIL A AND B

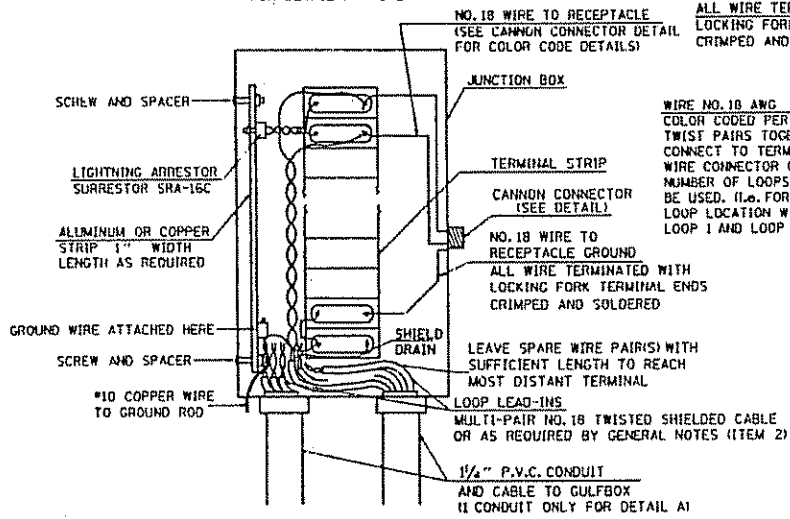

NOTES FOR JUNCTION BOX

1. ONE LIGHTNING ARRESTOR FOR EACH LOOP.
2. NUMBER OF TERMINALS ON TERMINAL STRIP TO BE DETERMINED BY NUMBER OF LOOPS. TERMINAL STRIP SHALL BE CINCH BARRIER TYPE 140 OR EQUIVALENT.
3. JUNCTION BOX SHALL BE WEATHER PROOF WITH SIZE DETERMINED BY NUMBER OF COMPONENTS. JUNCTION BOX SHALL BE 4" X 6" X 8" HOFFMAN BOX OR EQUIVALENT.
4. TERMINAL WITH MORE THAN 4 LOOPS WILL REQUIRE THE USE OF 2 CANNON CONNECTORS WITH LOOPS GROUPED BY DIRECTION OR AS DIRECTED BY THE ENGINEER.
5. THE COST OF INSTALLING THE TERMINAL FACILITY INCLUDES ALL VERTICAL WIRING, BOXES, CONNECTORS, VERTICAL CONDUIT, POST, GROUND ROD, SURRESTORS, AND LABOR, AND SHALL BE PAID FOR AT THE CONTRACT UNIT PRICE FOR TERMINAL FACILITY - 1 EACH.

CANNON CONNECTOR DETAIL

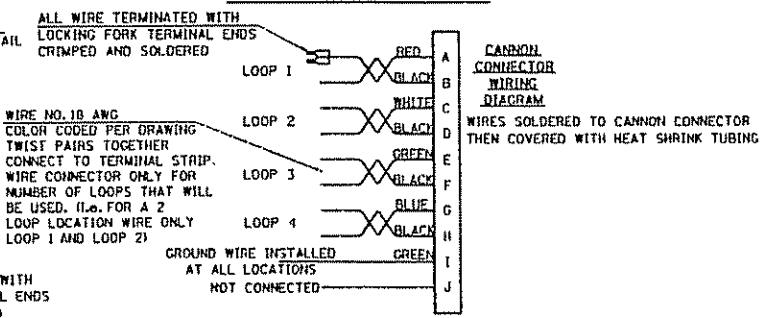

CONNECTOR VIEWED FROM REAR

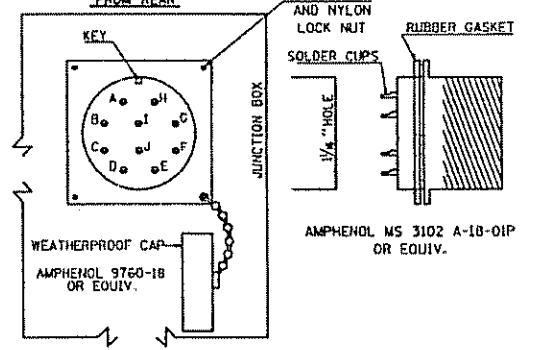

DETECTOR LOOP DETAILS; GULFBOX JUNCTION DETAIL

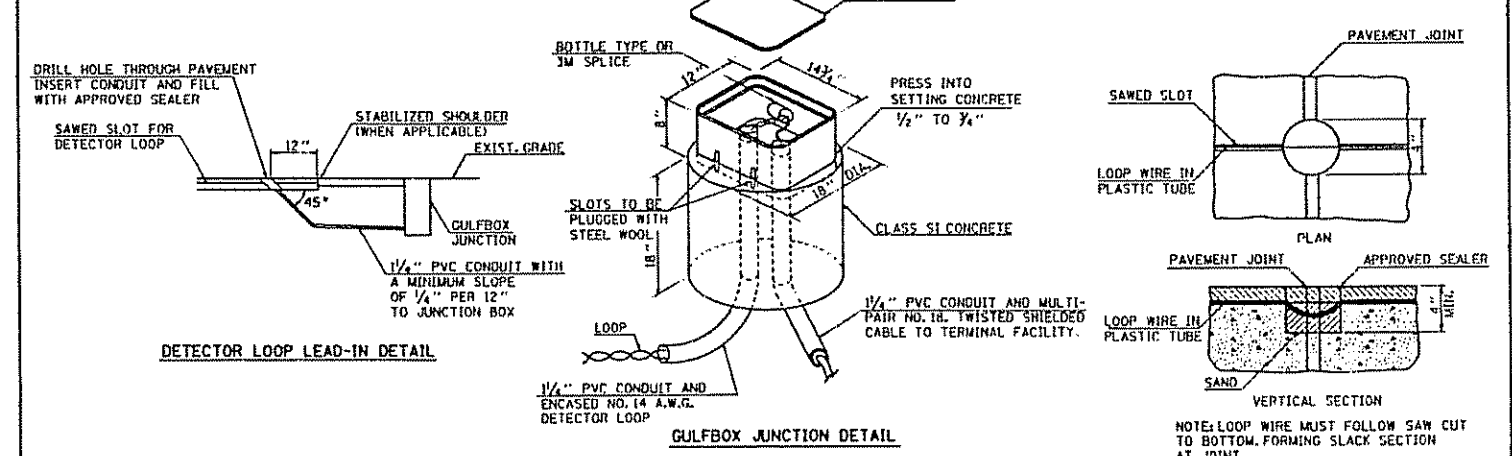

DETECTOR LOOP LEAD-IN DETAIL

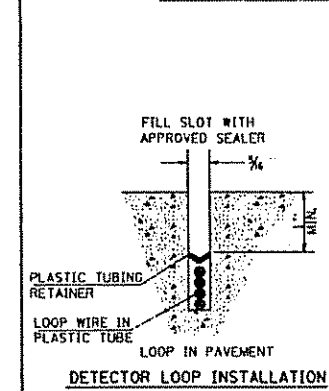

GULFBOX JUNCTION DETAIL

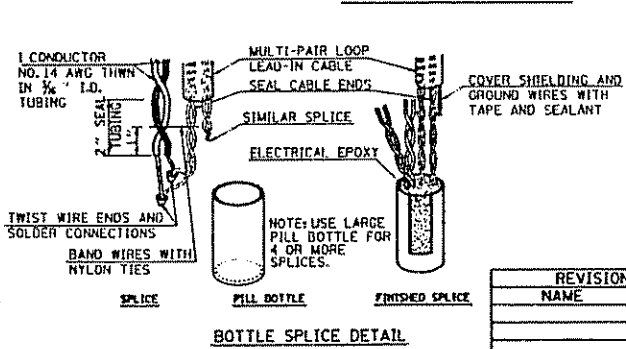

NOTE: NOT TO SCALE

ILLINOIS DEPARTMENT OF TRANSPORTATION
DETAIL FOR TRAFFIC COUNTERS
USING TERMINAL FACILITY
SPECIAL DETAIL

REVISIONS	
NAME	DATE

F.A.I. RTE.	SECTION	COUNTY	TOTAL SHEETS	SHEET NO.
55	*	MCLEAN	139	133
STA.		TO STA.		
FED. ROAD DIST. NO.		ILLINOIS	FED. AID PROJECT	
* (57-3-1, 57-3, 57-3-2, 57-2) RS				

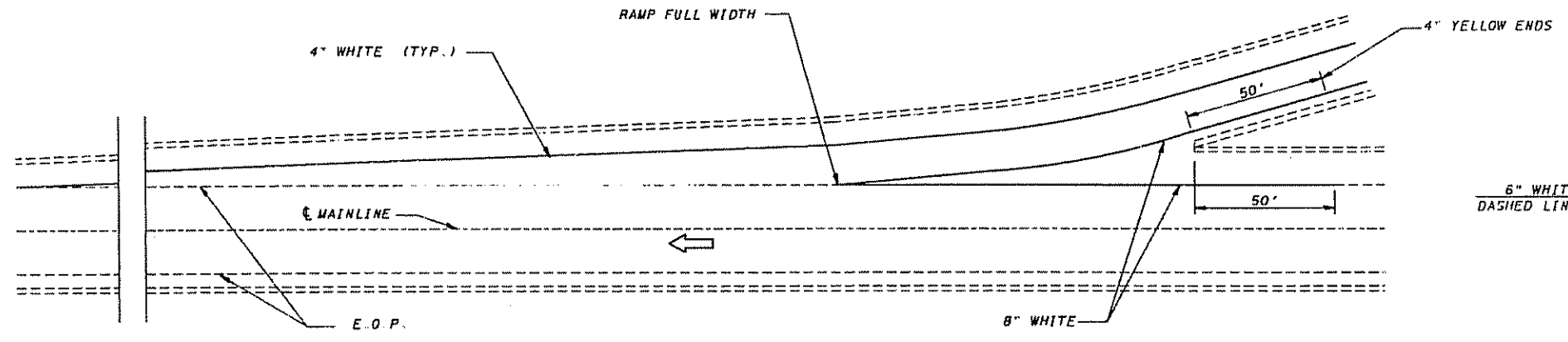

TYPICAL PAVEMENT MARKING FOR ENTRANCE RAMP TERMINALS

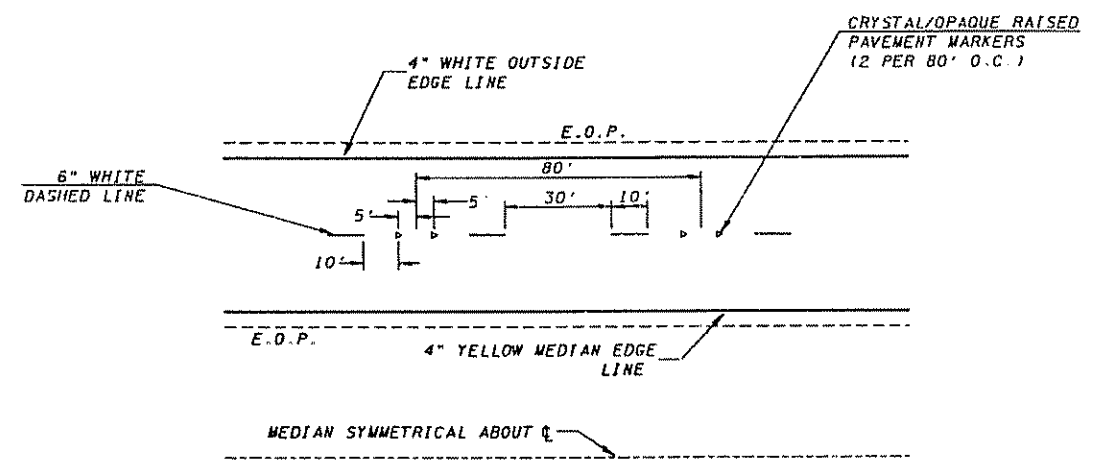

TYPICAL PAVEMENT MARKINGS

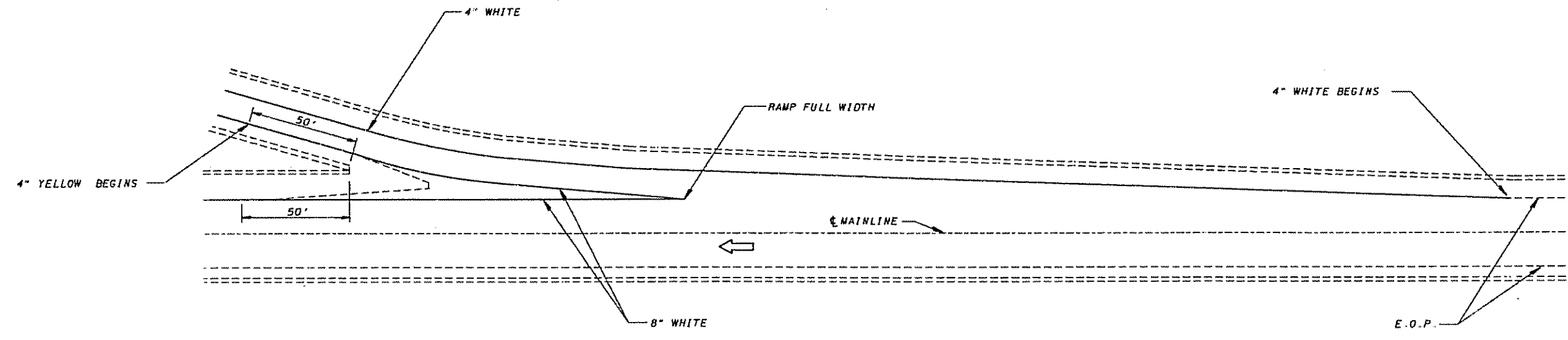

TYPICAL PAVEMENT MARKINGS FOR EXIT RAMP TERMINALS

JAN. 11, 2000
VEDDF100VDETAILS.DWG

F.A.I. RTE.	SECTION	COUNTY	TOTAL SHEETS	SHEET NO.
55	◆	MCLEAN	139	134
STA.		TO STA.		
FED. ROAD DIST. NO.		ILLINOIS FED. AID PROJECT		
■ 057-3-1, 57-3, 57-3-2, 57-21 RS				

**ILLINOIS STANDARD
W21-I102**

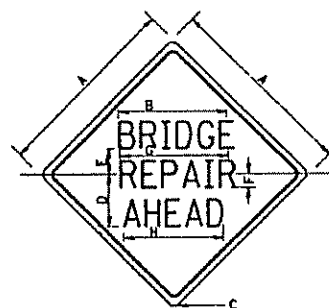

COLOR: LEGEND AND BORDER BLACK BACKGROUND ORANGE NON-REFLECTORIZED REFLECTORIZED

SIGN SIZE	DIMENSIONS							
	A	B	C	D	E	F	G	H
36 x 36	36.0	22.3	2.25	10.8	5.6	3.0	21.9	20.7
48 x 48	48.0	26.0	3.0	14.5	7.5	3.5	25.5	24.1

SIGN SIZE	SERIES LINES			MARGIN	BORDER	BLANK STD.
	1	2	3			
36 x 36	5C	5C	5C	0.6	0.8	B4-36D
48 x 48	7C	7C	7C	0.8	1.2	B4-48D

ALL DIMENSIONS IN INCHES.

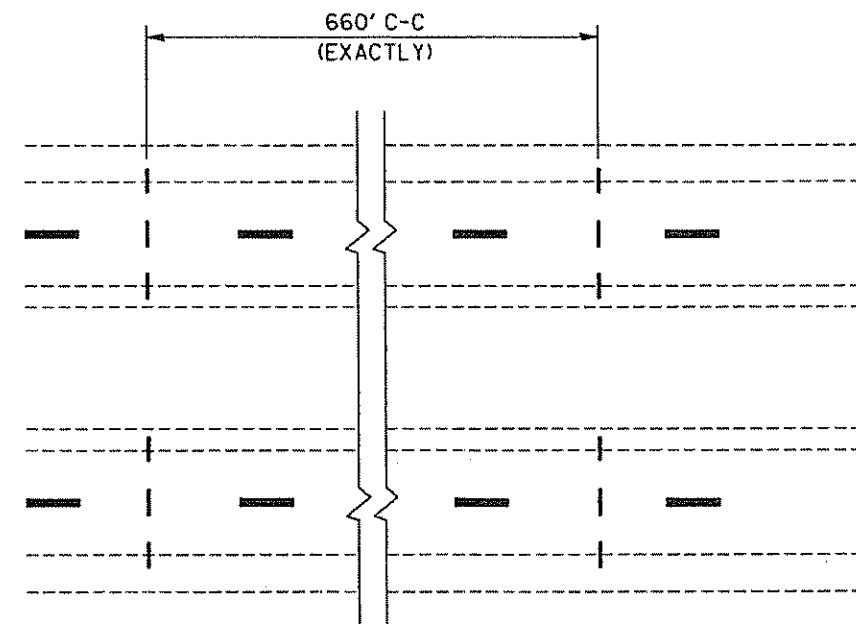

IT WILL BE NECESSARY TO HAVE A REPRESENTATIVE OF THE STATE POLICE PRESENT SO THAT THE ACCURACY OF MEASUREMENT CAN BE ATTESTED TO IN COURT.

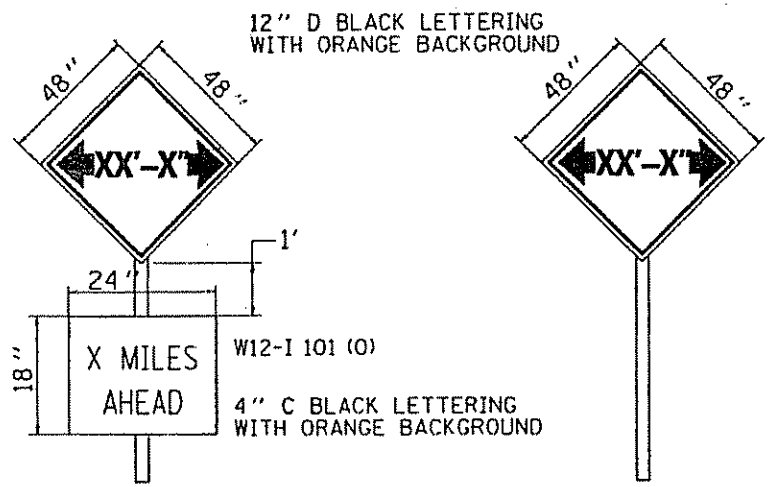

THE CONTRACTOR SHALL NOTIFY DISTRICT 3 BUREAU OF OPERATIONS 14 CALENDAR DAYS PRIOR TO INSTALLING ANY TRAFFIC CONTROL DEVICES THAT WILL RESTRICT THE PAVEMENT WIDTH.

WIDTH RESTRICTION SIGNING DETAILS

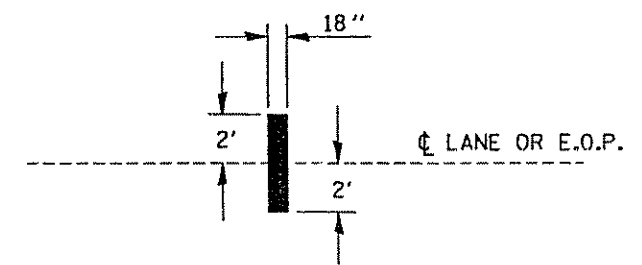

AERIAL SPEED CHECK ZONES

N.B. STA. 167+90 & STA. 174+50
S.B. STA. 441+50 & STA. 448+10

SIGNS SHALL BE PLACED AT THE FOLLOWING LOCATIONS:

- 2 EACH ON I-55 N.B. SOUTH OF THE TOWANDA INTERCHANGE.
- 1 EACH ON THE I-55 N.B. ENTRANCE RAMP AT TOWANDA.
- 2 EACH ON I-55 S.B. NORTH OF LEXINGTON INTERCHANGE.
- 1 EACH ON THE I-55 S.B. ENTRANCE RAMP AT LEXINGTON.
- 1 EACH AT INTERSECTIONS TO THE NORTH AND TO THE SOUTH OF S.N. 057-0162 ON C.H. 29.

JAN. 11, 2000
VED02100V01A1LS.DGN

F.A.I. RTE.	SECTION	COUNTY	TOTAL SHEETS	SHEET NO.
55	*	MCLEAN	139	135
STA.		TO STA.		
FED. ROAD DIST. NO.		ILLINOIS	FED. AID PROJECT	
* 57-3-1, 57-3, 57-3-2, 57-2) RS				

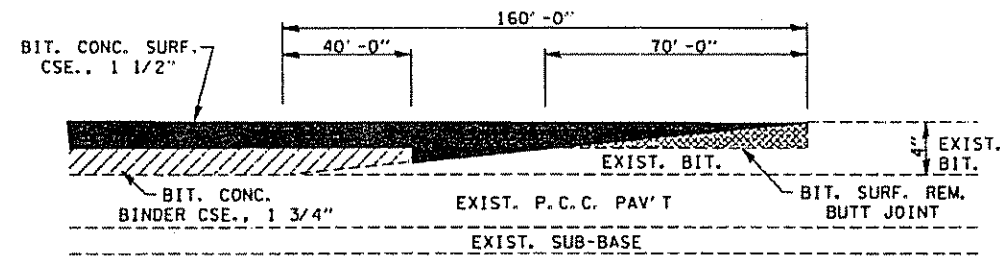

BITUMINOUS TAPER AT BEGINNING OF PROJECT

STA. 53+75 TO STA. 55+35 S.B. F.A.I. 55
 STA. 52+15 TO STA. 53+75 B.L. 55
 STA. 39+00 TO STA. 40+60 N.B. F.A.I. 55

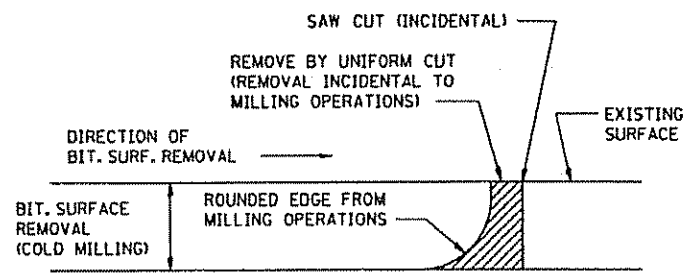

NOTE: WHEN MILLING OPERATIONS PRODUCE A ROUNDED EDGE, THEN A SAW CUT SHALL BE USED TO MANUFACTURE A PERPENDICULAR EDGE AS SHOWN IN THE DETAIL. THE ENGINEER SHALL BE THE SOLE JUDGE CONCERNING THE USE OF THIS DETAIL

BITUMINOUS DETAIL AT BUTT JOINTS

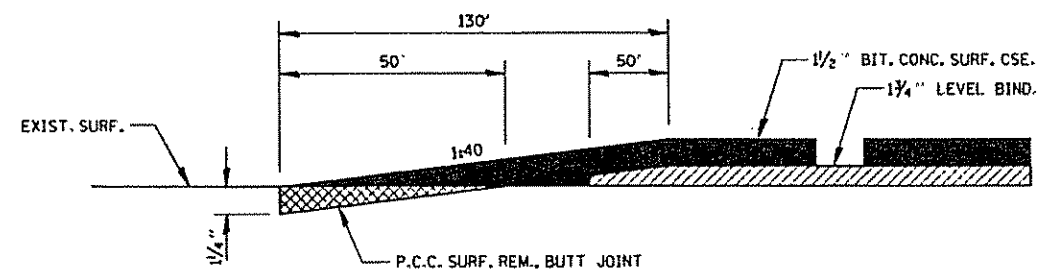

STA. 625+00 TO STA. 626+30
 F.A.I. 55 S.B. & N.B.

F.A.I. RTE. NO.	SECTION	COUNTY	TOTAL SHEETS	SHEET NO.
55	*	MCLEAN	139	136
STA.		TO STA.		
FED. ROAD DIST. NO.		ILLINOIS FED. AID PROJECT		
* (57-3-1, 57-3, 57-3-2, 57-2) RS				

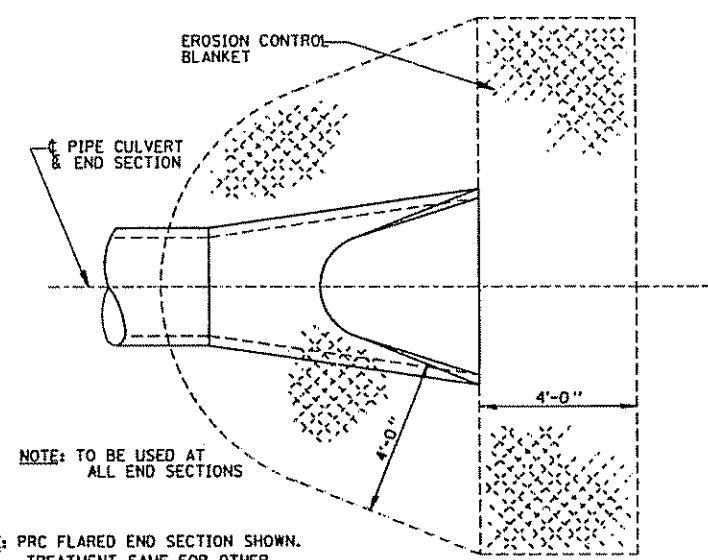

NOTE: TO BE USED AT ALL END SECTIONS

NOTE: PRC FLARED END SECTION SHOWN. TREATMENT SAME FOR OTHER END SECTIONS.

DETAIL OF EROSION CONTROL BLANKET LINING AROUND END SECTION

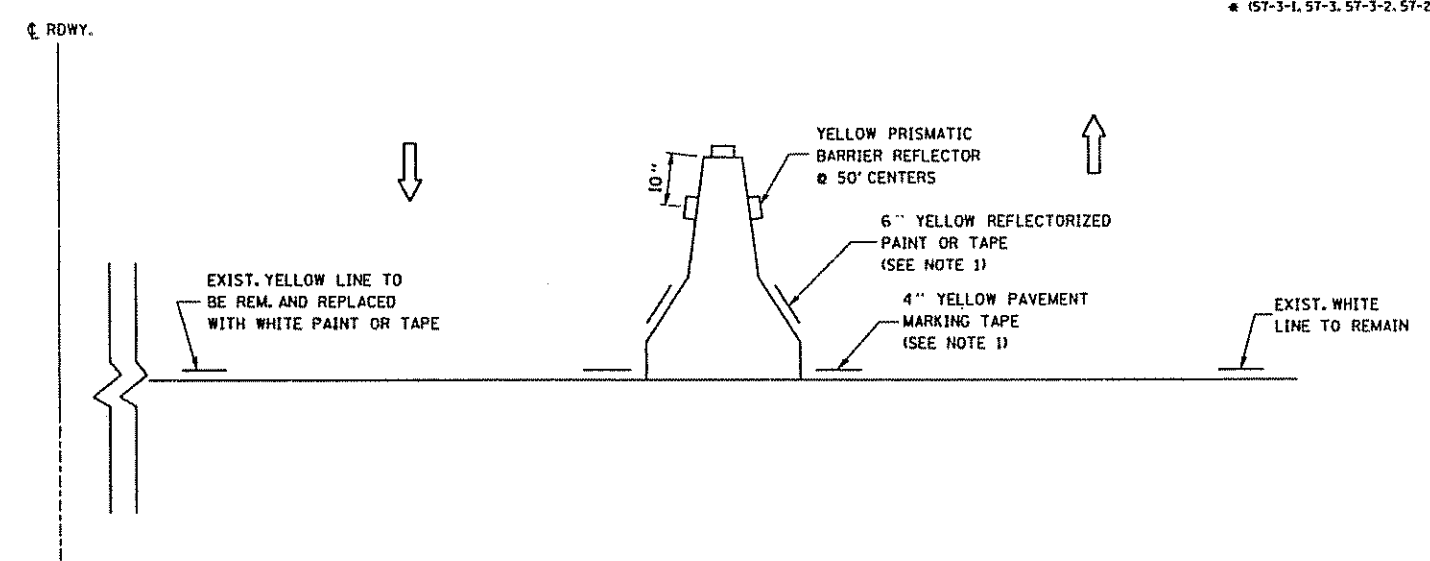

NOTES:

1. THE CONTRACTOR HAS THE OPTION OF USING EITHER THE LINE ON THE TEMPORARY CONCRETE BARRIER OR ON THE PAVEMENT.
2. THE COST OF THE REFLECTORS AND THE BARRIER/PAVEMENT MARKING LINE IS INCLUDED IN THE COST OF THE TEMPORARY CONCRETE BARRIER.

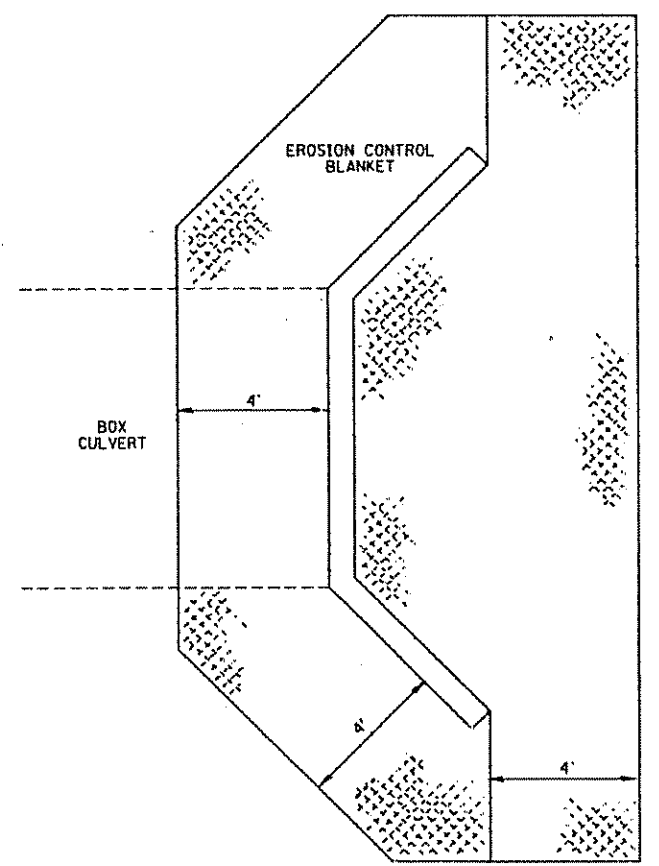

EROSION CONTROL BLANKET AT BOX CULVERT END SECTIONS

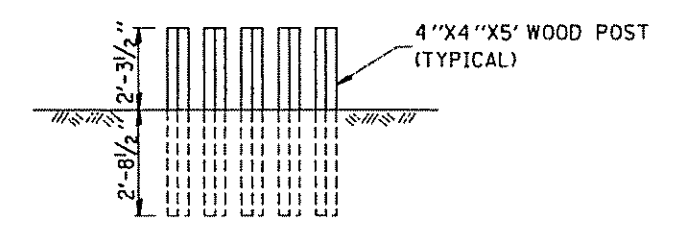
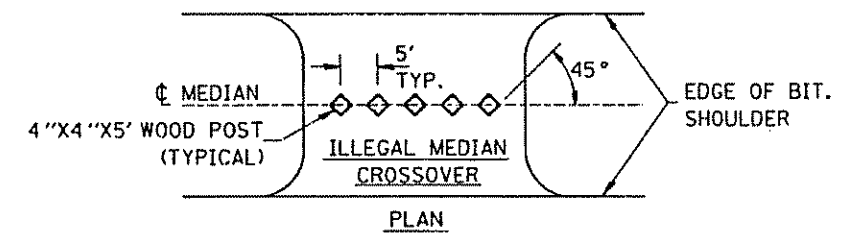

WOOD POST DETAIL

JAN. 11, 2000
VED021001.DETAILS.DGN

F.A.I. RTE.	SECTION	COUNTY	TOTAL SHEETS	SHEET NO.
55	*	MCLEAN	139	137
STA.	TO STA.			
FED. ROAD DIST. NO.	ILLINOIS FED. AID PROJECT			
* 57-3-1, 57-3, 57-3-2, 57-2) RS				

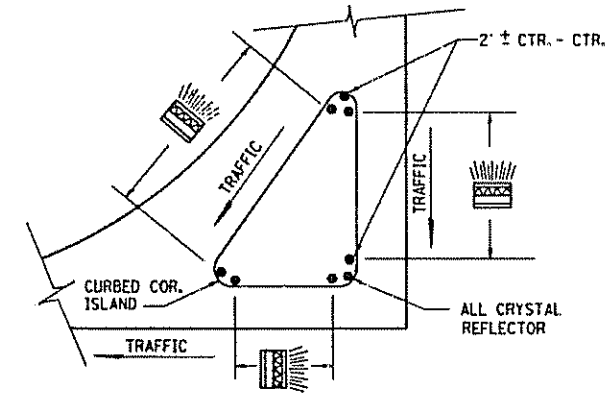
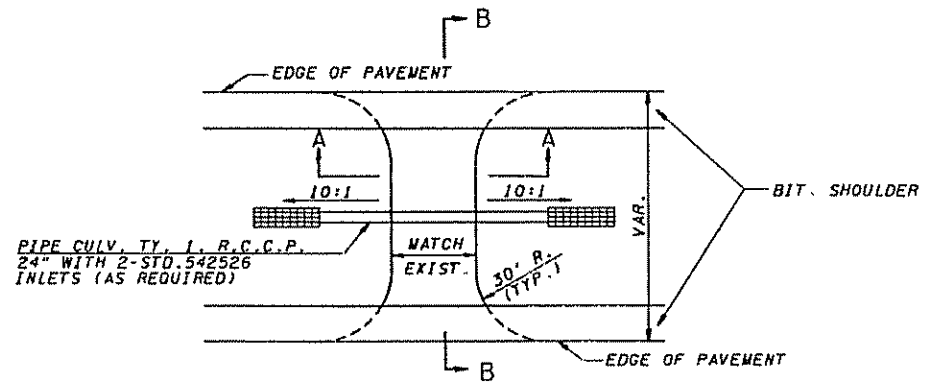

PRISMATIC REFLECTORS

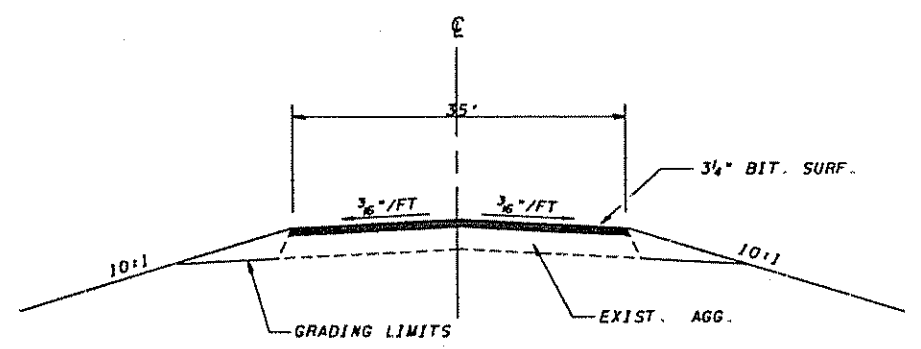

SECTION A-A

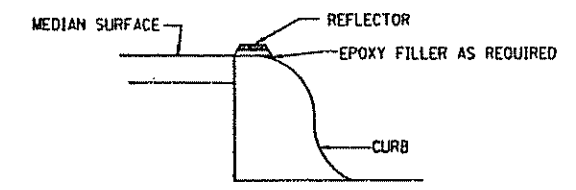

SECTION VIEW

NOTES

1. PRISMATIC REFLECTORS SHALL BE MONO-DIRECTIONAL AND POSITIONED SO THAT THE REFLECTIVE FACE IS FACING THE APPROACHING TRAFFIC.
2. PRISMATIC REFLECTORS SHALL BE SECURED IN PLACE WITH AN EPOXY ADHESIVE.
3. PRISMATIC REFLECTORS SHALL BE EITHER AMBER OR CRYSTAL IN COLOR.

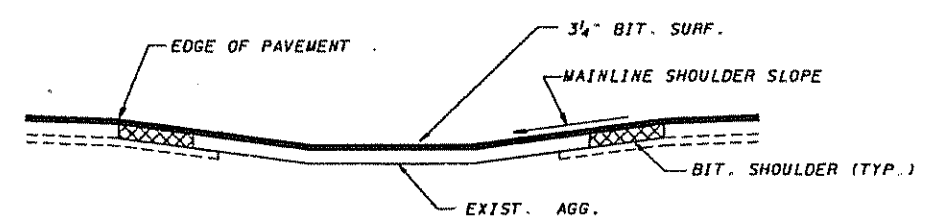

SECTION B-B

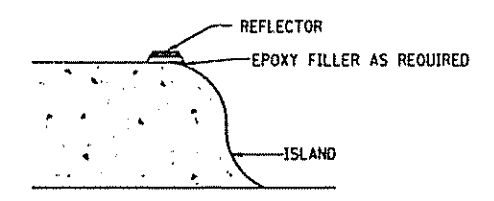

SECTION VIEW

NOTES

1. PRISMATIC REFLECTORS SHALL BE MONO-DIRECTIONAL AND POSITIONED SO THAT THE REFLECTIVE FACE IS FACING THE APPROACHING TRAFFIC.
2. PRISMATIC REFLECTORS SHALL BE SECURED IN PLACE WITH AN EPOXY ADHESIVE.
3. PRISMATIC REFLECTORS SHALL BE EITHER AMBER OR CRYSTAL IN COLOR.

BITUMINOUS MAINTENANCE CROSSOVER

JAN. 11, 2000
VED021001.DETAILS.DGN

F.A.I. RTE.	SECTION	COUNTY	TOTAL SHEETS	SHEET NO.
55	*	MCLEAN	139	138
STA.		TO STA.		
FED. ROAD DIST. NO.	ILLINOIS	FED. AID PROJECT		
* 57-3-1, 57-3, 57-3-2, 57-2) RS				

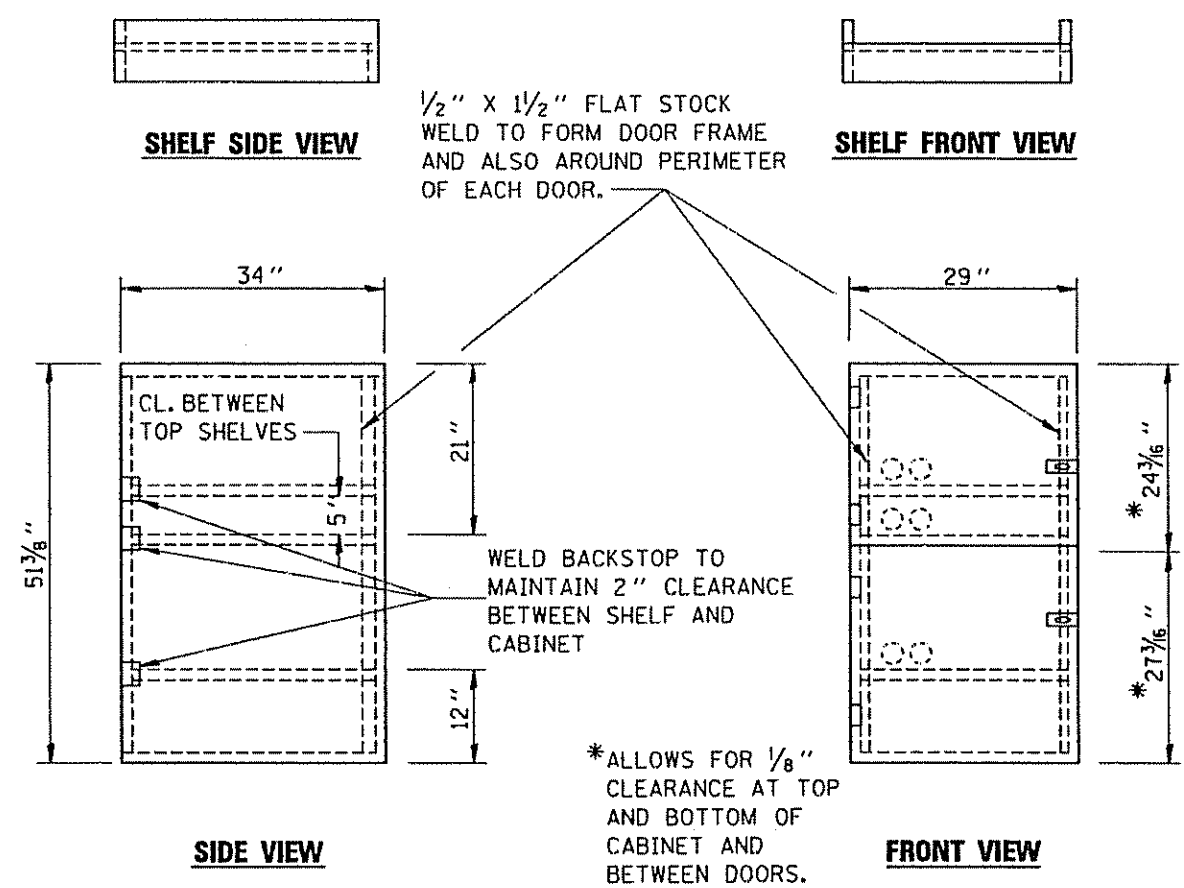

- NOTES:
1. USE 16 GAUGE STEEL FOR CABINET.
 2. THE TOP SHELF SHALL SLIDE IN OR OUT WITH THE TOP DOOR OPEN.
 3. ALL HINGES AND HASPS WILL BE WELDED TO THE CABINET.
 4. ALL EDGES SHALL BE GROUND SMOOTH.
 5. TWO (2" DIA.) ACCESS HOLES WILL BE REQUIRED FOR EACH SHELF.
 6. CABINET SHALL BE PAINTED WITH TWO COATS OF FLAT PAINT.
 7. 2 EACH MATCHING KEY PADLOCKS, WITH 3 KEYS PROVIDED, MASTER MODEL 3 T OR EQUIVALENT.
 8. 4 EACH PLAIN STEEL, NON-REMOVABLE PIN, NO HOLE 4"x4" SQUARE CORNER HINGES TO BE WELDED ON.
 9. 2 EACH EXTRA HEAVY, PLAIN STEEL, FIXED STAPLE, NO HOLE, 7 $\frac{1}{4}$ " HASPS TO BE WELDED ON.

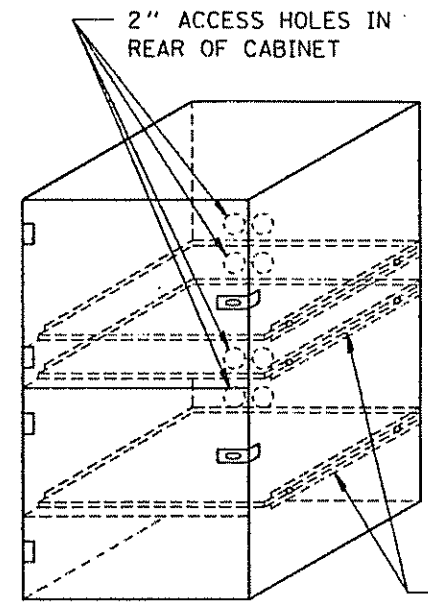

FLAT STOCK DIMENSIONS VARY DEPENDING ON TYPE OF ROLLER ASSEMBLY.

LOCKABLE COMPUTER CABINET

JAN. 11, 2000
LEDD21001.DETA/ILS.DGN

P.A. NO.	SECTION	COUNTY	SHEET NO.	TOTAL SHEETS
95	0	MCLEAN	139	139
STA.		TO STA.		
FED. ROAD DIST. NO.		BLK.	FED. ROAD PROJECT	

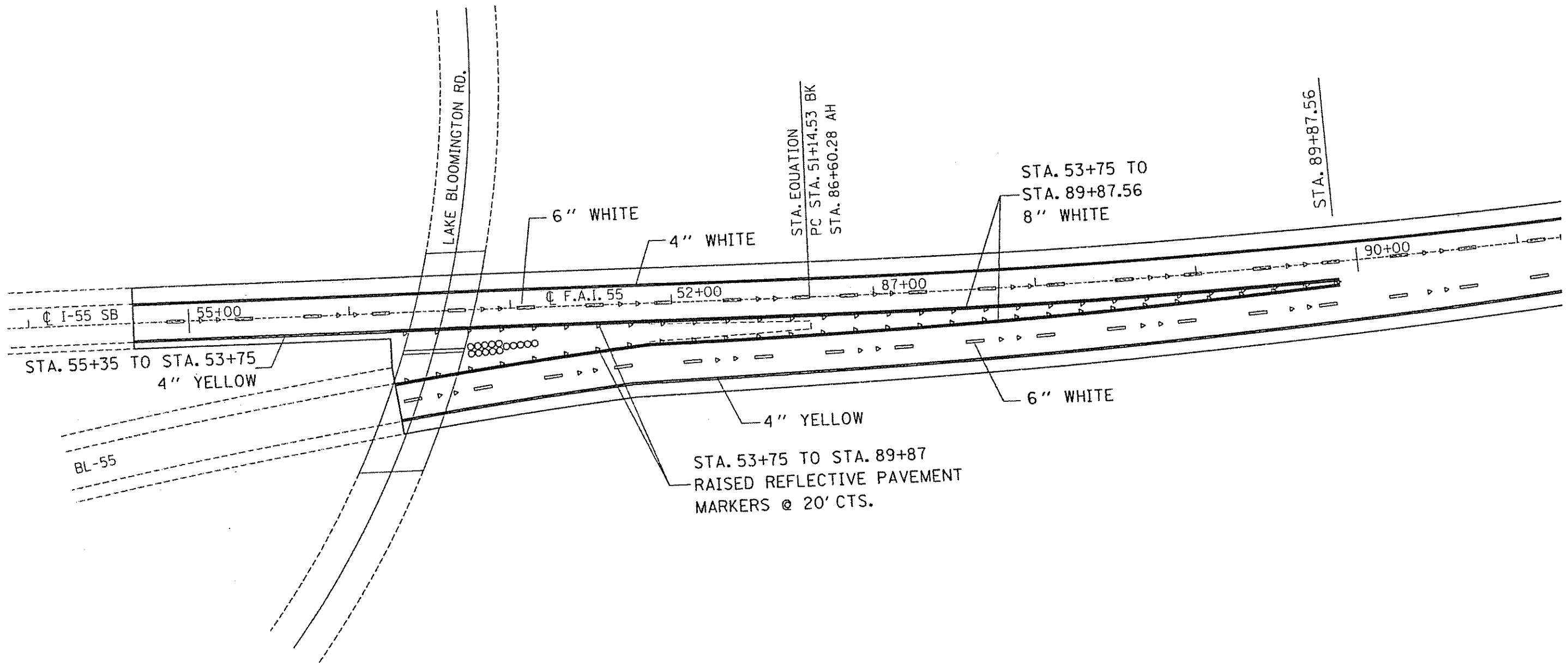

PAVEMENT MARKING DETAIL
S.B. I-55 & B.L. 55

JAN. 11, 2000
 \ED02100\SHEETS.DGN