

EXISTING TYPICAL SECTION US 34 (OGDEN AVE.)  
STA. 213+47 TO STA. 217+69

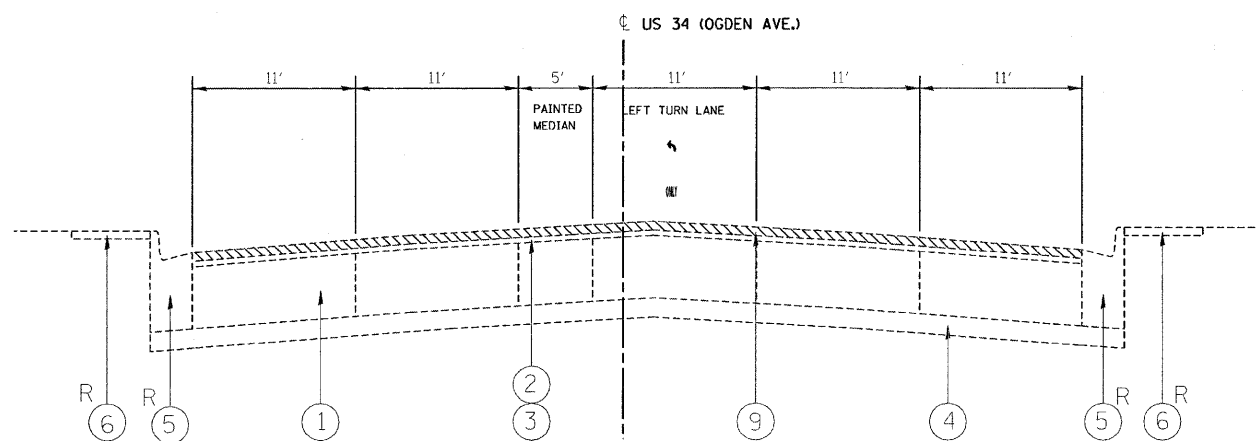

EXISTING TYPICAL SECTION US 34 (OGDEN AVE.)  
STA. 217+69 TO STA. 220+77

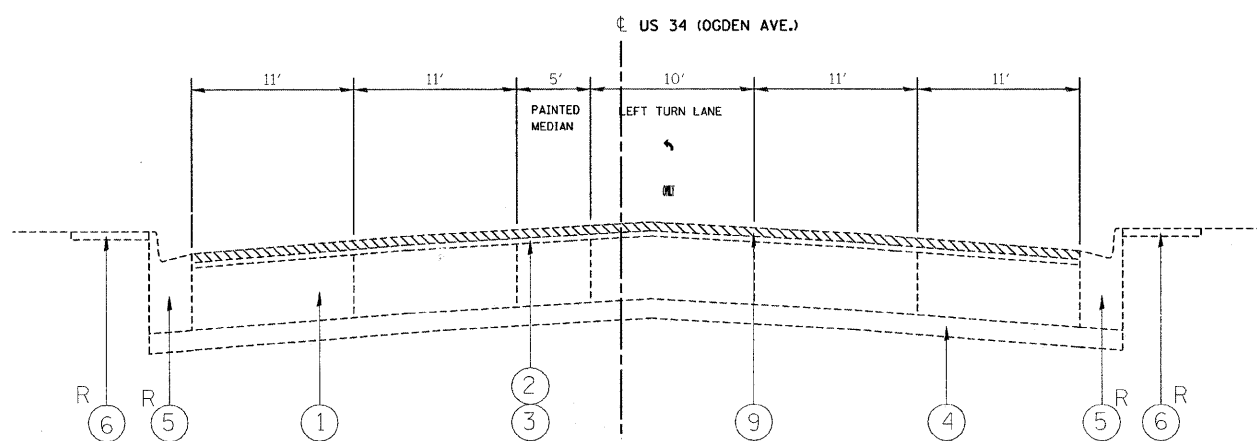

EXISTING TYPICAL SECTION US 34 (OGDEN AVE.)  
STA. 220+77 TO STA. 224+29

**LEGEND:**

- ① EXISTING P.C.C. PAVEMENT, ±10"
- ② EXISTING HOT-MIX ASPHALT SURFACE, ±8"
- ③ EXISTING HOT-MIX ASPHALT SURFACE (AFTER MILLING), ±6"
- ④ EXISTING STABILIZED SUB-BASE
- ⑤ EXISTING COMBINATION CONCRETE CURB AND GUTTER, TYPE B-6.12
- ⑥ EXISTING SIDEWALK
- ⑦ EXISTING CORRUGATED MEDIAN
- ⑧ EXISTING HOT-MIX ASPHALT SHOULDER
- ⑨ PROP. HOT-MIX ASPHALT SURFACE REMOVAL, 2 1/2"
- ⑩ PROP. POLYMERIZED LEVELING BINDER (MACHINE METHOD), IL-4.75, N50, 3/4"
- ⑪ PROP. POLYMERIZED HOT-MIX ASPHALT SURFACE COURSE, MIX "F", N90, 1 3/4"
- R CURB AND GUTTER REMOVAL AND REPLACEMENT

FILE NAME =	USER NAME = steedpa	DESIGNED -	REVISED -	<b>STATE OF ILLINOIS DEPARTMENT OF TRANSPORTATION</b>	EXISTING TYPICAL SECTIONS US 34 (OGDEN AVE.)--I-355 TO WARWICK AVE.		F.A.P. RTE. 311	SECTION 9Y-RS-6	COUNTY	TOTAL SHEETS 41	SHEET NO. 6	
c:\pw_work\pwwork\stedpa\dms89735\design\oo.dgn	PLOT SCALE = 50,0000' / IN.	DRAWN -	REVISED -		SCALE:	SHEET NO. OF SHEETS	STA. TO STA.	FED. ROAD DIST. NO. 1 ILLINOIS FED. AID PROJECT				
	PLOT DATE = 1/9/2009	CHECKED -	REVISED -					CONTRACT NO. 60A85				
		DATE -	REVISED -									