

EXISTING TYPICAL SECTION
STA. 207+06 TO STA. 207+76

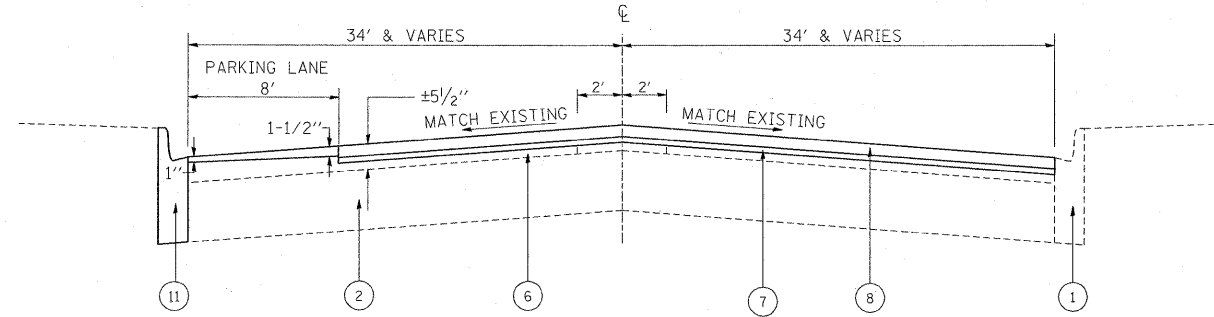

PROPOSED TYPICAL SECTION
STA. 207+06 TO STA. 207+76

LEGEND

1. EXISTING COMBINATION CONCRETE CURB AND GUTTER
 2. EXISTING P.C. CONCRETE PAVEMENT ± 9"
 3. EXISTING HMA SURFACE COURSE ± 5/2"
 4. PROPOSED HMA SURFACE REMOVAL (2/4")
 5. PROPOSED HMA SURFACE REMOVAL (VARIABLE DEPTH 1" TO 1/2")
 6. EXISTING HMA SURFACE OVERLAY AFTER MILLING
 7. PROPOSED POLYMERIZED LEVELING BINDER (MACHINE METHOD), IL-4.75, N50 (3/4")
 8. PROPOSED HMA SURFACE COURSE, MIX "D", N70 (1/2")
 9. PROPOSED HMA SURFACE COURSE, MIX "D", N70 (VARIABLE DEPTH - 1" TO 1/2")
 10. EXISTING CONCRETE MEDIAN
 11. PROPOSED COMBINATION CONCRETE CURB & GUTTER REMOVAL & REPLACEMENT WHERE NECESSARY. EXACT LOCATIONS TO BE DETERMINED IN THE FIELD BY THE ENGINEER.
 12. MEDIAN REMOVAL PARTIAL DEPTH
- * NOTE: SEE PLAN SHEETS FOR LOCATIONS OF PARKING LANES. WHERE THERE ARE NO PARKING LANES, MILL AND RESURFACE THE FULL DEPTH OF 2/4" TO THE CURB AND GUTTER.

NOTES

THE CONTRACTOR SHALL MILL FIRST (BEFORE CLASS D PATHING)

FILE NAME =	USER NAME = guillaumejp	DESIGNED -	REVISED -	STATE OF ILLINOIS DEPARTMENT OF TRANSPORTATION	26TH STREET /25TH PLACE (IL 43 TO IL 50) TYPICAL SECTIONS	F.A.U. RTE.	SECTION	COUNTY	TOTAL SHEETS	SHEET NO.
c:\pw_work\pwtidot\guillaumejp\d0117416\011904-Design.dgn	DRAWN -	REVISED -	1459			(0505.1, 0606 & 0707) RS-12	COOK	32	6	
PLOT SCALE = 50.0001' / IN.	CHECKED -	REVISED -	CONTRACT NO. 62818							
PLOT DATE = 1/9/2009	DATE -	REVISED -	FED. ROAD DIST. NO. 1 ILLINOIS FED. AID PROJECT							
				SCALE:	SHEET NO. OF SHEETS	STA. TO STA.				