

EXISTING TYPICAL SECTION
ILL RTE. 176
STATION:
27+76 TO 230+83

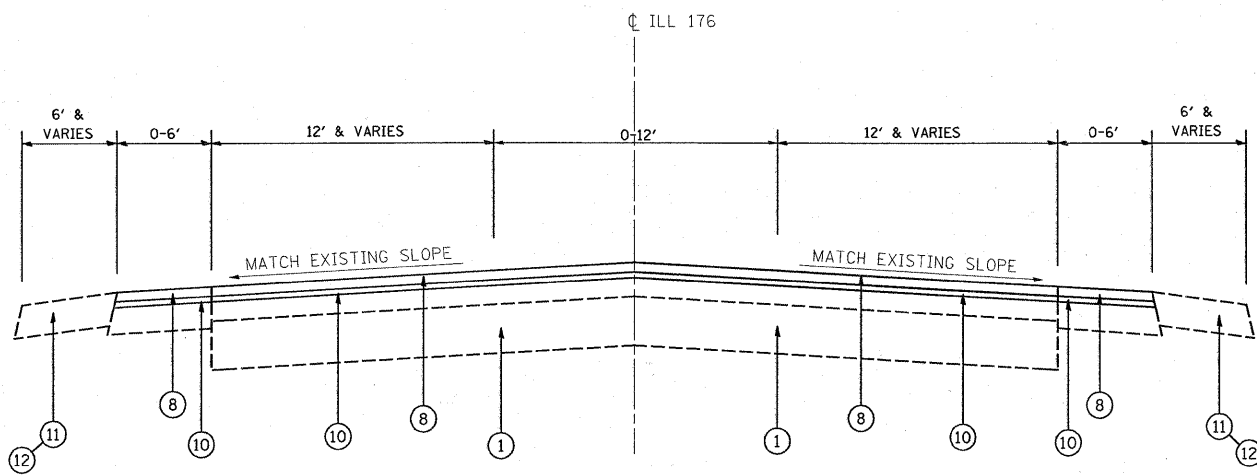

PROPOSED TYPICAL SECTION
ILL RTE. 176
STATION:
27+76 TO 230+83

LEGEND

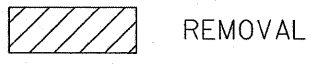

- ① EXISTING PCC BASE COURSE, 9''(±)
- ② EXISTING HOT-MIX ASPHALT SURFACE COURSE (BEFORE MILLING), 5 1/2''(±)
- ③ EXISTING HOT-MIX ASPHALT SHOULDER, 8''
- ④ EXISTING AGGREGATE SHOULDER, 6''
- ⑤ EXISTING CONCRETE CURB & GUTTER*
- ⑥ PROPOSED HOT-MIX ASPHALT SURFACE REMOVAL - 2 1/4''
(3 1/4''(±) OF HOT-MIX ASPHALT TO REMAIN)
- ⑦ PROPOSED HOT-MIX ASPHALT SURFACE REMOVAL - 2 1/2''
(3''(±) OF HOT-MIX ASPHALT TO REMAIN)
- ⑧ PROPOSED HOT-MIX ASPHALT SURFACE COURSE, MIX "D", N70, 1 1/2''
- ⑨ PROPOSED HOT-MIX ASPHALT SURFACE COURSE, MIX "F", N90, 1 3/4''
- ⑩ PROPOSED POLYMERIZED LEVELING BINDER (MM), IL-4.75, N50, 3/4''
- ⑪ PROPOSED AGGREGATE WEDGE SHOULDER, TYPE B
- ⑫ PROPOSED GRADING AND SHAPING SHOULDERS

NOTE:

1. RIGHT TURN LANE FROM STA. 79+72 TO 82+08 LT. AND STA. 184+13 TO 186+11 RT.
2. ALL HMA SHOULDERS TO BE MILLED AND RESURFACED
3. HMA SURFACE REMOVAL TO BE DONE PRIOR TO PAVEMENT PATCHING

FILE NAME =	USER NAME = wilgreendp	DESIGNED -	REVISED -	STATE OF ILLINOIS DEPARTMENT OF TRANSPORTATION	IL 176 (IL 31 TO FOX RIVER) EXISTING AND PROPOSED TYPICAL SECTIONS		F.A.P. RTE.	SECTION	COUNTY	TOTAL SHEETS	SHEET NO.
c:\p\work\FWIDOT\WILGREENDP\dms89645\design_00.dgn		DRAWN -	REVISED -		335	146RS-3	MCHENRY	29	7		
PLOT SCALE = 50.0000' / 1".		CHECKED -	REVISED -		SCALE: SHEET NO. 3 OF 31 SHEETS STA. TO STA.		FED. ROAD DIST. NO. 1 ILLINOIS FED. AID PROJECT		CONTRACT NO. 62905		
PLOT DATE = 1/13/2009		DATE -	REVISED -								