

# STAGING DETAILS FOR PAVING OPERATIONS

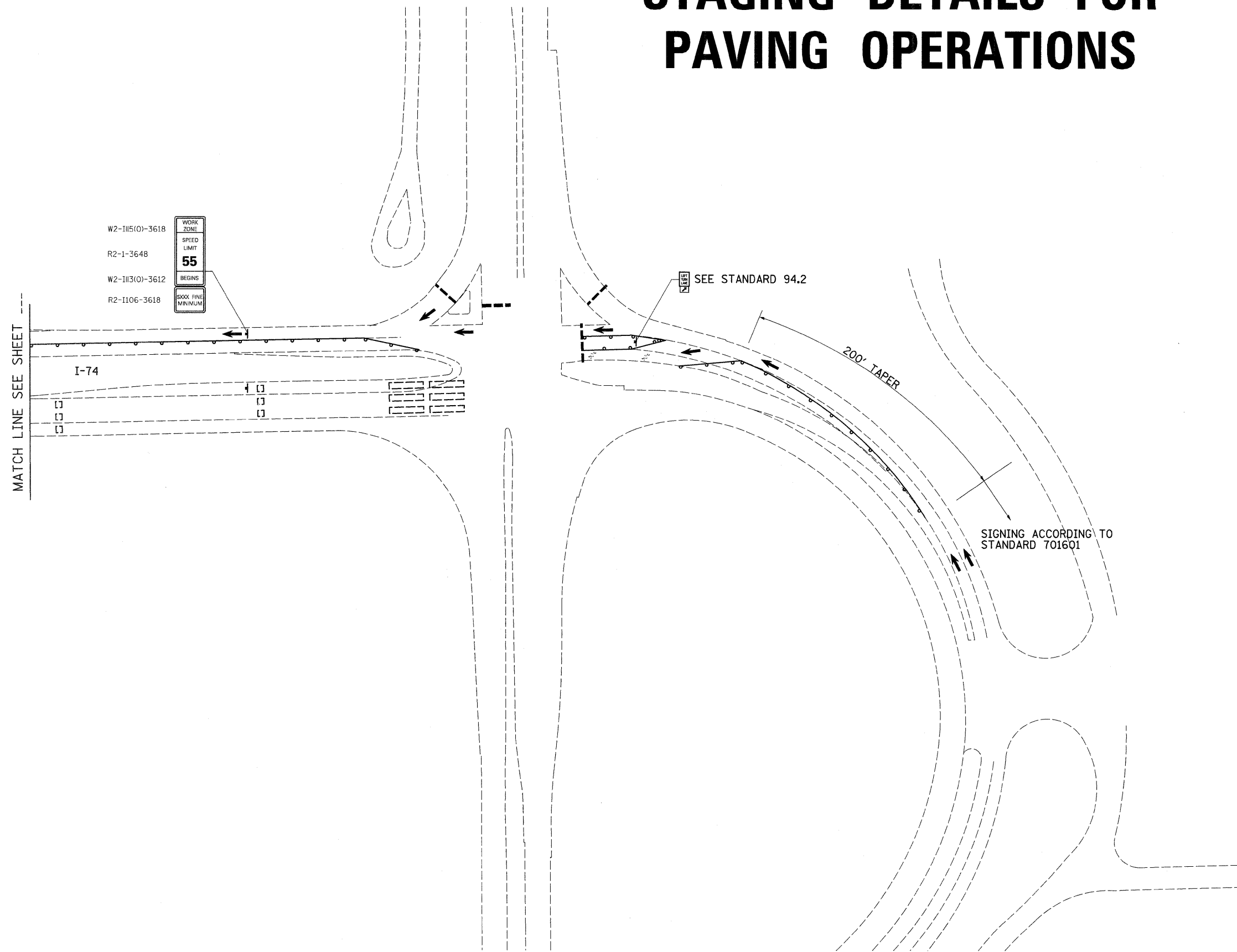

FILE NAME =	USER NAME = hensonke	DESIGNED -	REVISED -	<b>STATE OF ILLINOIS DEPARTMENT OF TRANSPORTATION</b>	<b>STAGE 10 - STAGING PLANS</b>				F.A.I. RTE.	SECTION	COUNTY	TOTAL SHEETS	SHEET NO.		
C:\pwork\PWIDOT\HENSONKE\dms33952\d0805-shit-staging.dgn		DRAWN -	REVISED -		SCALE:	SHEET NO.	OF	SHEETS	STA.	TO STA.	74	*	ROCK ISLAND	246	101
	PLOT SCALE = 50.0000' / IN.	CHECKED -	REVISED -		CONTRACT NO. 64A97										
	PLOT DATE = Fri Feb 06 10:38:46 2009	DATE -	REVISED -		ILLINOIS FED. AID PROJECT										

# SPECIAL SIGN DETAILS

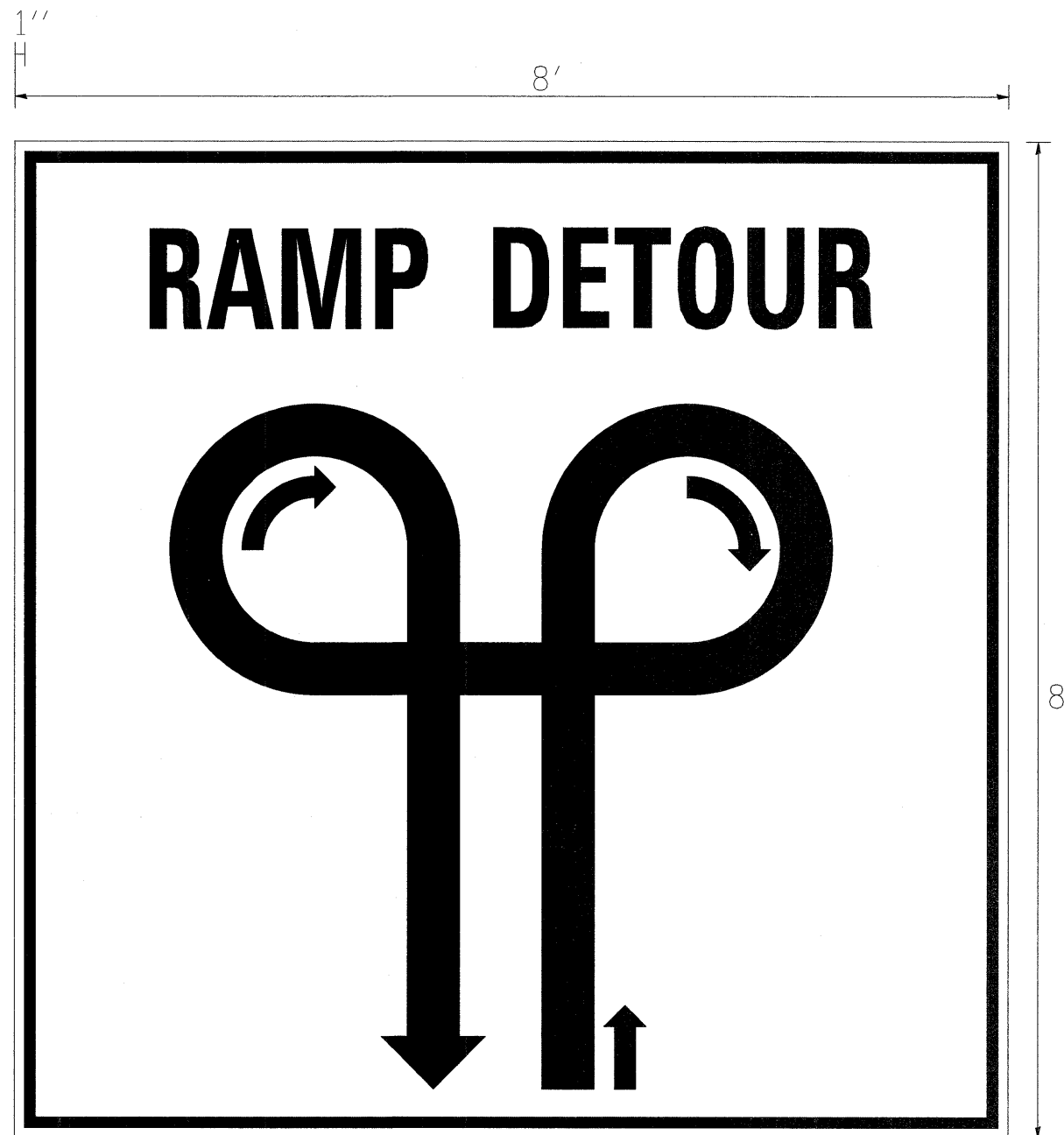
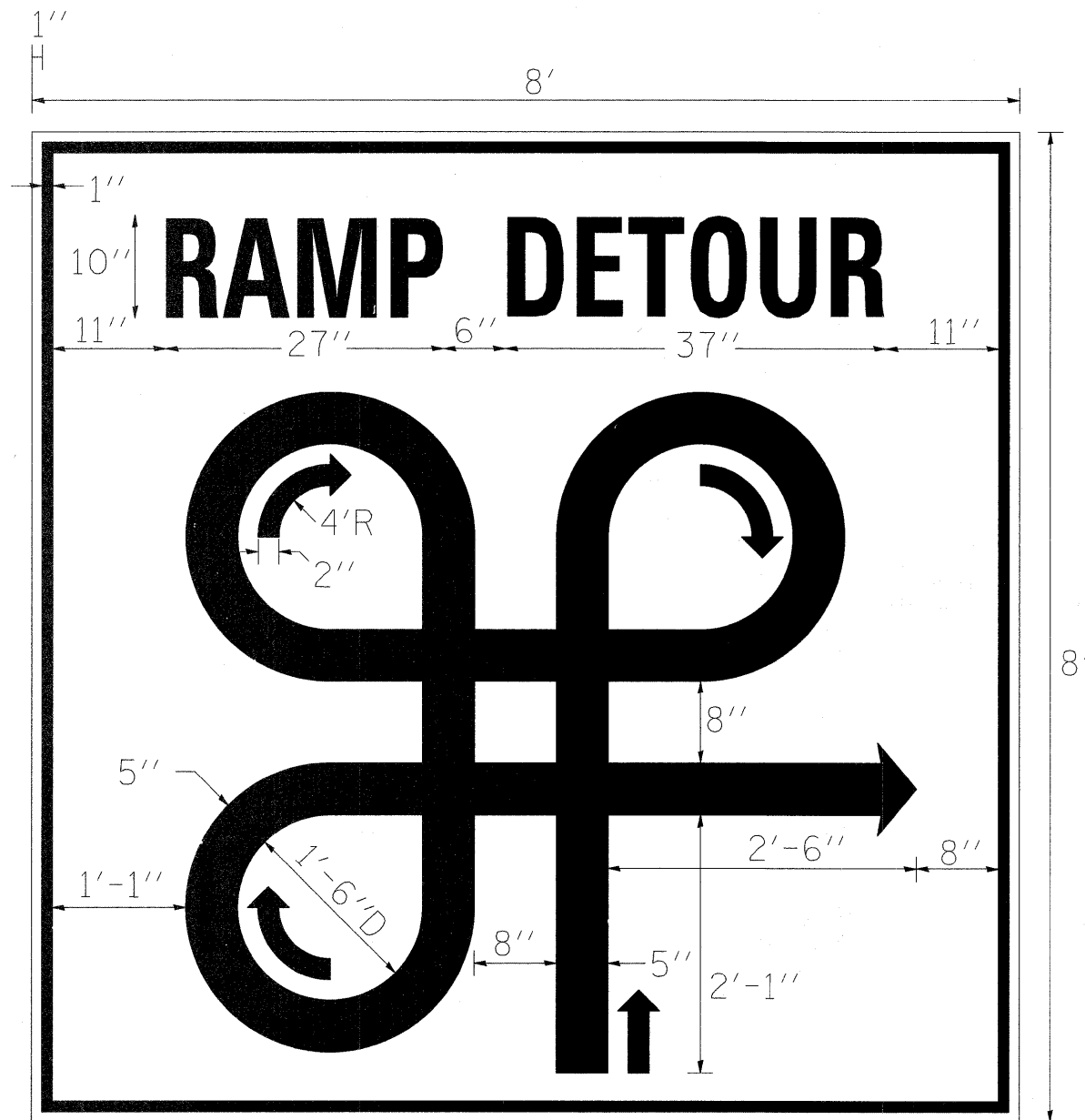

10" GOTHIC C FONT LETTERS  
 ORANGE - BACKGROUND  
 BLACK - LETTERS AND SYMBOLS

NOTE: SEE SPECIAL PROVISIONS FOR MOUNTING DETAILS

FILE NAME =	USER NAME = duncanfa	DESIGNED -	REVISED -	<b>STATE OF ILLINOIS DEPARTMENT OF TRANSPORTATION</b>	<b>SPECIAL SIGN DETAILS</b>				F.A.I. RTE.	SECTION	COUNTY	TOTAL SHEETS	SHEET NO.
ct:\pw_work\PWIDOT\DUNCANFA\dms33952\d85805-shr-ta.dgn		DRAWN -	REVISED -		505	*	ROCK ISLAND	246	102				
PLOT SCALE = 50.0000' / IN.		CHECKED -	REVISED -		CONTRACT NO. 64A97								
PLOT DATE = Fri Feb 06 10:54:46 2009		DATE -	REVISED -		ILLINOIS FED. AID PROJECT								
				SCALE:	SHEET NO.	OF	SHEETS	STA.	TO STA.				

# SPECIAL SIGN DETAILS

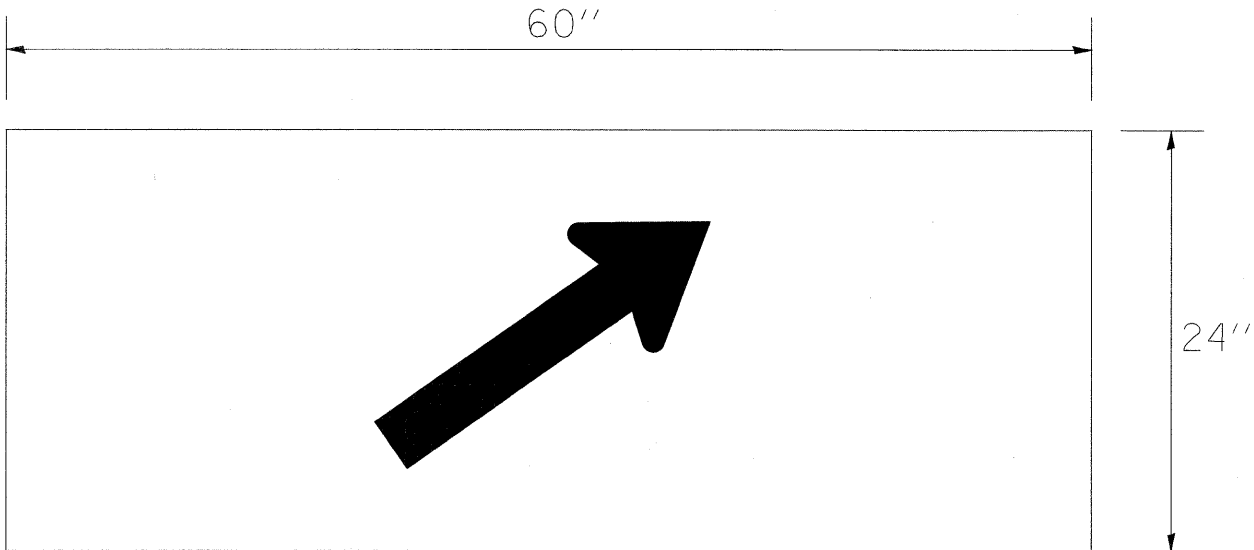
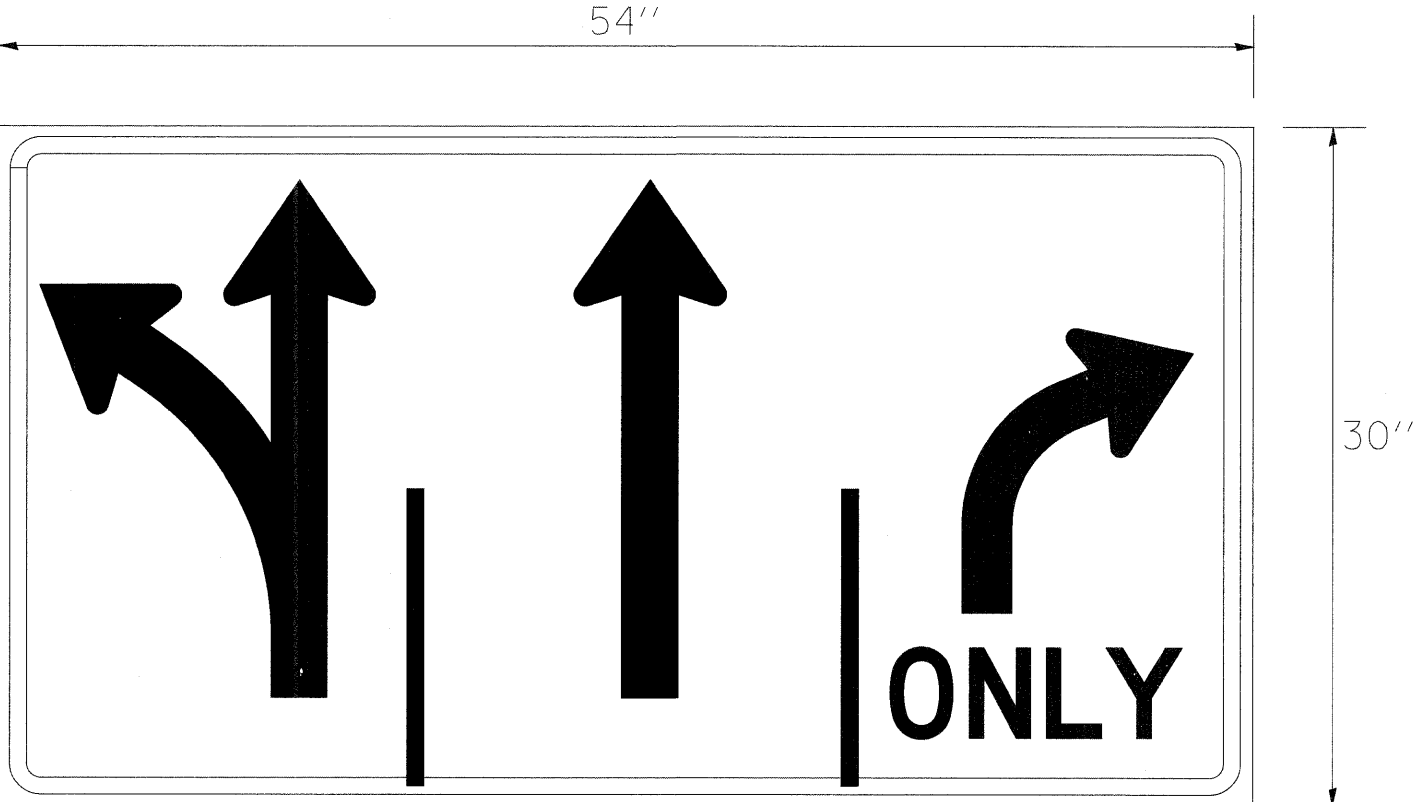
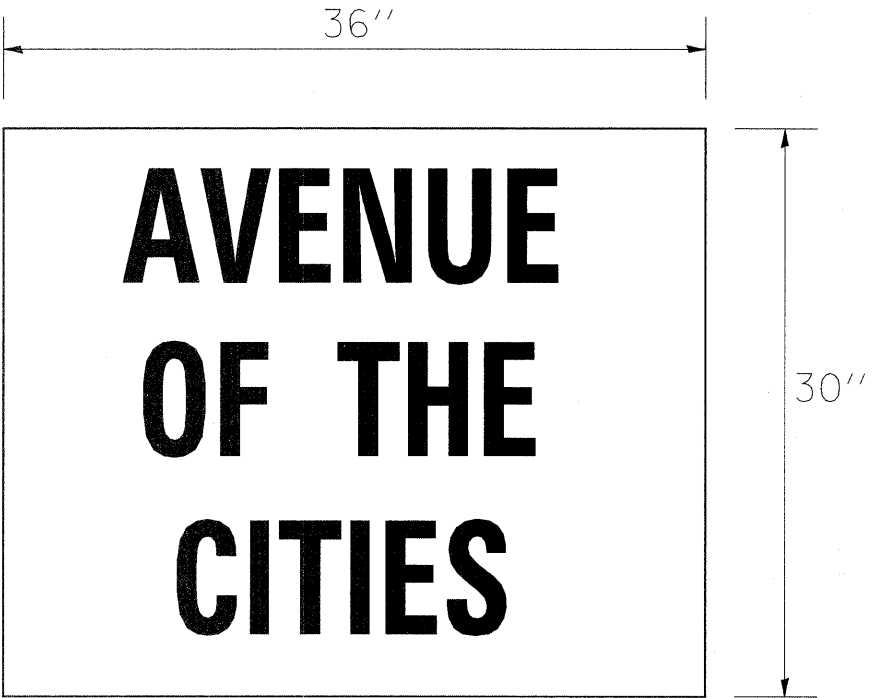

SIGN DESIGNS WILL BE GIVEN AT PRE-CONSTRUCTION MEETING.

NOTE: SEE SPECIAL PROVISIONS FOR MOUNTING DETAILS

FILE NAME =	USER NAME = duncanfa	DESIGNED -	REVISED -	<b>STATE OF ILLINOIS DEPARTMENT OF TRANSPORTATION</b>	<b>SPECIAL SIGN DETAILS</b>				F.A. RTE.	SECTION	COUNTY	TOTAL SHEETS	SHEET NO.
cr:\pw_work\PWIDOT\DUNCANFA\dms33952\dms33952-005-shr-ta.dgn		DRAWN -	REVISED -		505	*	ROCK ISLAND	246	103				
PLOT SCALE = 50.0000' / IN.		CHECKED -	REVISED -		SCALE: SHEET NO. OF SHEETS STA. TO STA.				ILLINOIS FED. AID PROJECT				
PLOT DATE = Fri Feb 06 10:54:54 2009		DATE -	REVISED -						CONTRACT NO. 64A97				

• 81-(1-2,1,2-2)RS-1&M

# DETOUR FOR IL 5 EB TO I-74 EB (RAMP F)



OVERHEAD AND GROUND MOUNT BREAKAWAY  
STEEL SUPPORT SIGNS TO BE COVERED OR ALTERED

SIGN TRUSS AT I-74 EB  
PLACE "CLOSED" PLATE OVER "I-74 EAST" →

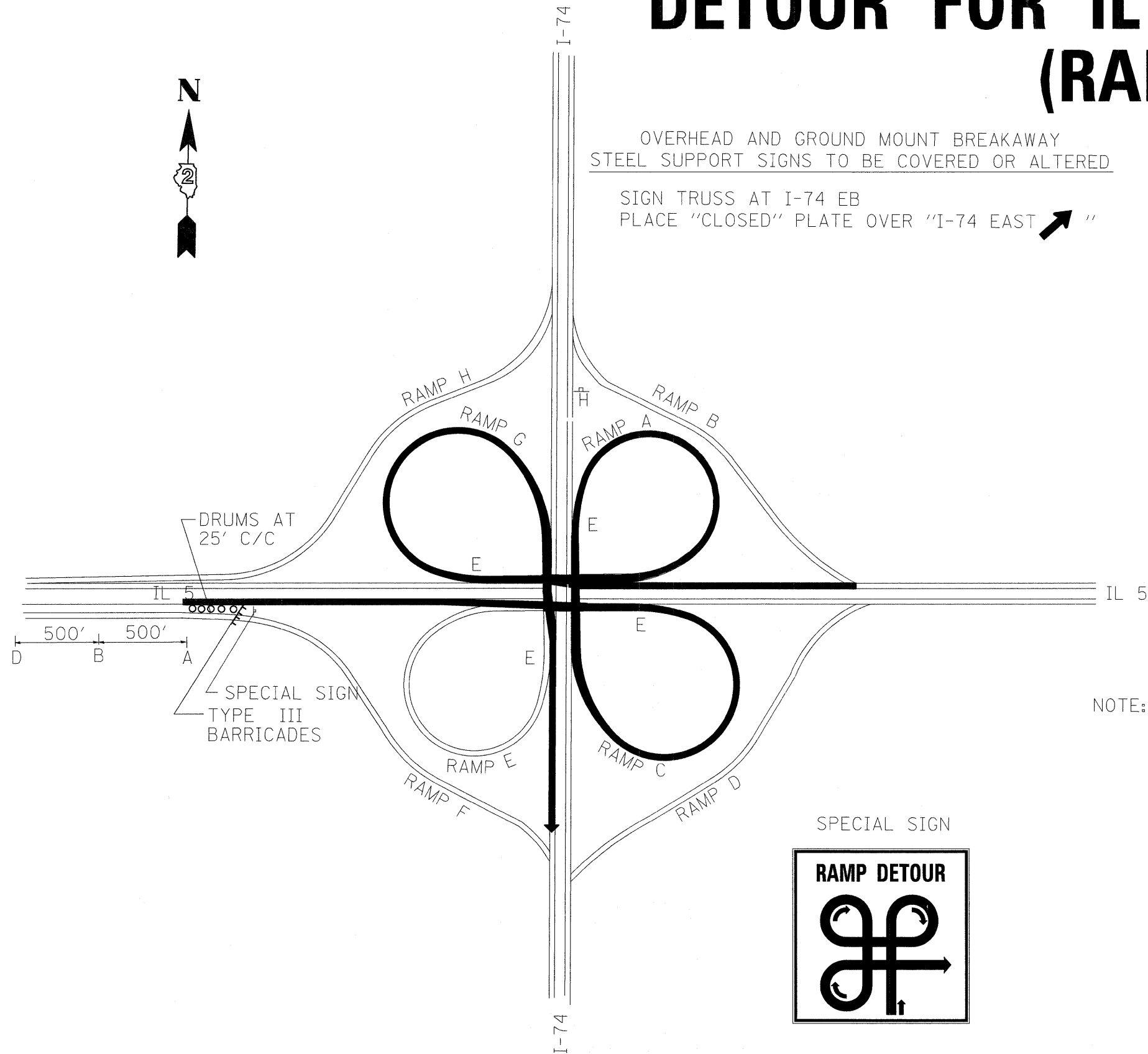

- A. **DETOUR** M4-8(0)(30x15)
- WEST** M3-4 30X15 BLUE
- 74** M1-1 36 RED, WHITE, BLUE
- ↑** M6-3 30X18 ORANGE
- B. **RAMP DETOUR AHEAD** 48"
- D. **RAMP CLOSED AHEAD** 48"
- H. **END DETOUR** M4-8A 24X18
- E. **DETOUR** M4-8(0)(30x15)
- WEST** M3-4 30X15 BLUE
- 74** M1-1 36 RED, WHITE, BLUE
- ↗** M6-2R 30X18 ORANGE

NOTE: THE TYPE III BARRICADE SHALL HAVE A RAMP CLOSED SIGN. REVISE SIGN R11-2 (Road Closed) to "RAMP CLOSED"

**RAMP CLOSED** 48X30 BLACK ON WHITE

THE CONTRACTOR SHALL BE RESPONSIBLE FOR PROVIDING ALL SIGNS REQUIRED FOR THE RAMP CLOSURES AND DETOURS.

SEE SPECIAL SIGN DETAILS SHEET  
THE RAMPS SHALL NOT BE CLOSED AT THE SAME TIME.

Powerdraft: special signs I74&IL5

FILE NAME =	USER NAME = duncanfa	DESIGNED -	REVISED -	<b>STATE OF ILLINOIS DEPARTMENT OF TRANSPORTATION</b>	<b>DETOUR FOR IL 5 EB TO I-74 EB</b>				F.A.I. RTE.	SECTION	COUNTY	TOTAL SHEETS	SHEET NO.
ct:\pw_work\PWIDOT\DUNCANFA\dms33952\d08005-shi-ta.dgn		DRAWN -	REVISED -		505	*	ROCK ISLAND	246	104				
PLOT SCALE = 50.0000' / IN.		CHECKED -	REVISED -		SCALE: SHEET NO. OF SHEETS STA. TO STA.				ILLINOIS FED. AID PROJECT		CONTRACT NO. 64A97		
PLOT DATE = Fri Feb 06 10:54:45 2009		DATE -	REVISED -										

# DETOUR FOR I-74 WB (NB) TO IL 5 EB (RAMP D)

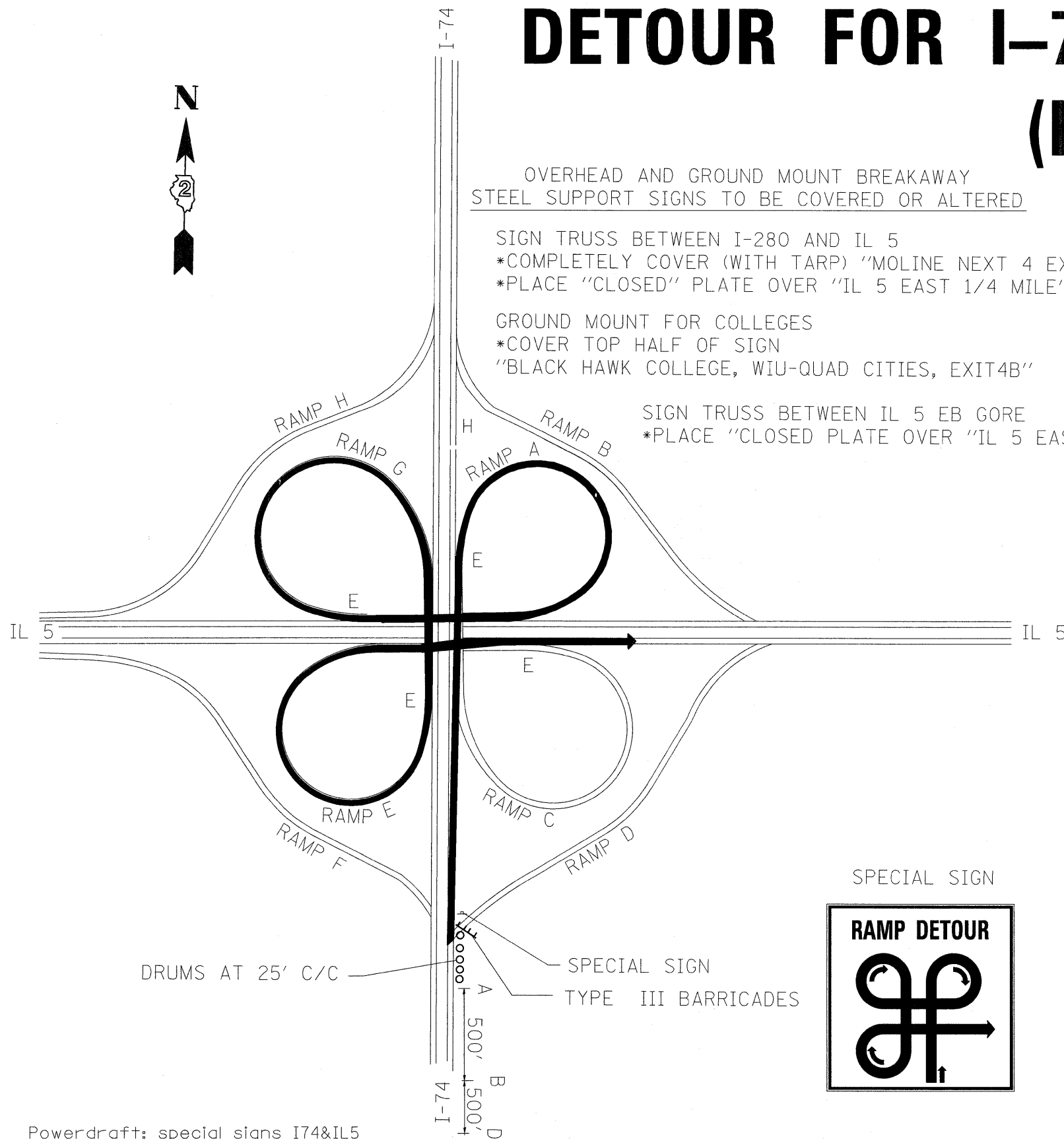

OVERHEAD AND GROUND MOUNT BREAKAWAY  
STEEL SUPPORT SIGNS TO BE COVERED OR ALTERED

SIGN TRUSS BETWEEN I-280 AND IL 5  
\*COMPLETELY COVER (WITH TARP) "MOLINE NEXT 4 EXITS"  
\*PLACE "CLOSED" PLATE OVER "IL 5 EAST 1/4 MILE"

GROUND MOUNT FOR COLLEGES  
\*COVER TOP HALF OF SIGN  
"BLACK HAWK COLLEGE, WIU-QUAD CITIES, EXIT4B"

SIGN TRUSS BETWEEN IL 5 EB GORE  
\*PLACE "CLOSED" PLATE OVER "IL 5 EAST"

DRUMS AT 25' C/C

SPECIAL SIGN  
TYPE III BARRICADES

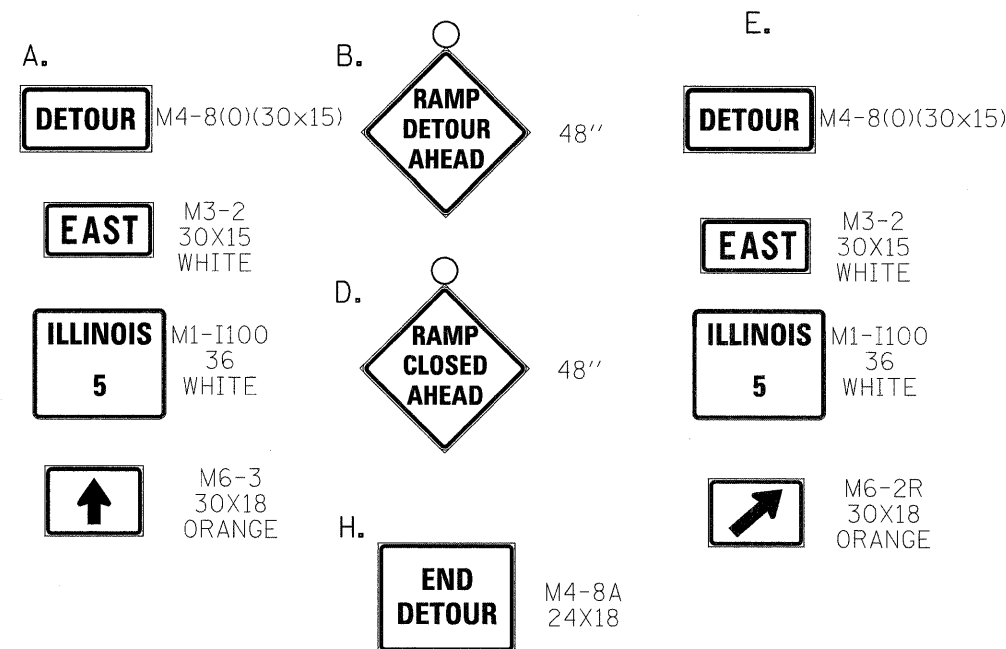
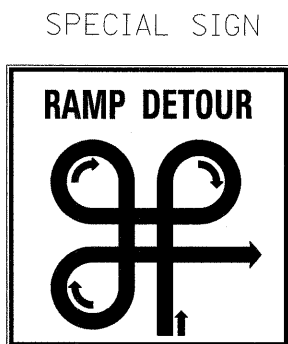

NOTE: THE TYPE III BARRICADE SHALL HAVE  
A RAMP CLOSED SIGN. REVISE SIGN  
R11-2 (Road Closed) to "RAMP CLOSED"



THE CONTRACTOR SHALL BE RESPONSIBLE  
FOR PROVIDING ALL SIGNS REQUIRED FOR  
THE RAMP CLOSURES AND DETOURS.

SEE SPECIAL SIGN DETAILS SHEET  
THE RAMPS SHALL NOT BE CLOSED AT THE  
SAME TIME.

Powerdraft: special signs I74&IL5

FILE NAME =	USER NAME = duncanfa	DESIGNED -	REVISED -	<b>STATE OF ILLINOIS DEPARTMENT OF TRANSPORTATION</b>	<b>DETOUR FOR I-74 WB TO IL 5 EB</b>				F.A.I. RTE.	SECTION	COUNTY	TOTAL SHEETS	SHEET NO.
es\pwwork\PWIDOT\DUNCANFA\dms33952\d08005-shr-ts.dgn		DRAWN -	REVISED -		505	*	ROCK ISLAND	246	105				
PLOT SCALE = 50.0000' / IN.		CHECKED -	REVISED -		CONTRACT NO. 64A97				ILLINOIS FED. AID PROJECT				
PLOT DATE = Fri Feb 06 10:54:46 2009		DATE -	REVISED -		SCALE:	SHEET NO.	OF	SHEETS	STA.	TO STA.			

# DETOUR FOR IL 5 WB TO I-74 WB (NB) (RAMP B)

OVERHEAD AND GROUND MOUNT BREAKAWAY  
STEEL SUPPORT SIGNS TO BE COVERED OR ALTERED

SIGN TRUSS AT I-74 WB  
\*PLACE "CLOSED" PLATE OVER "I-74 WEST DAVENPORT"

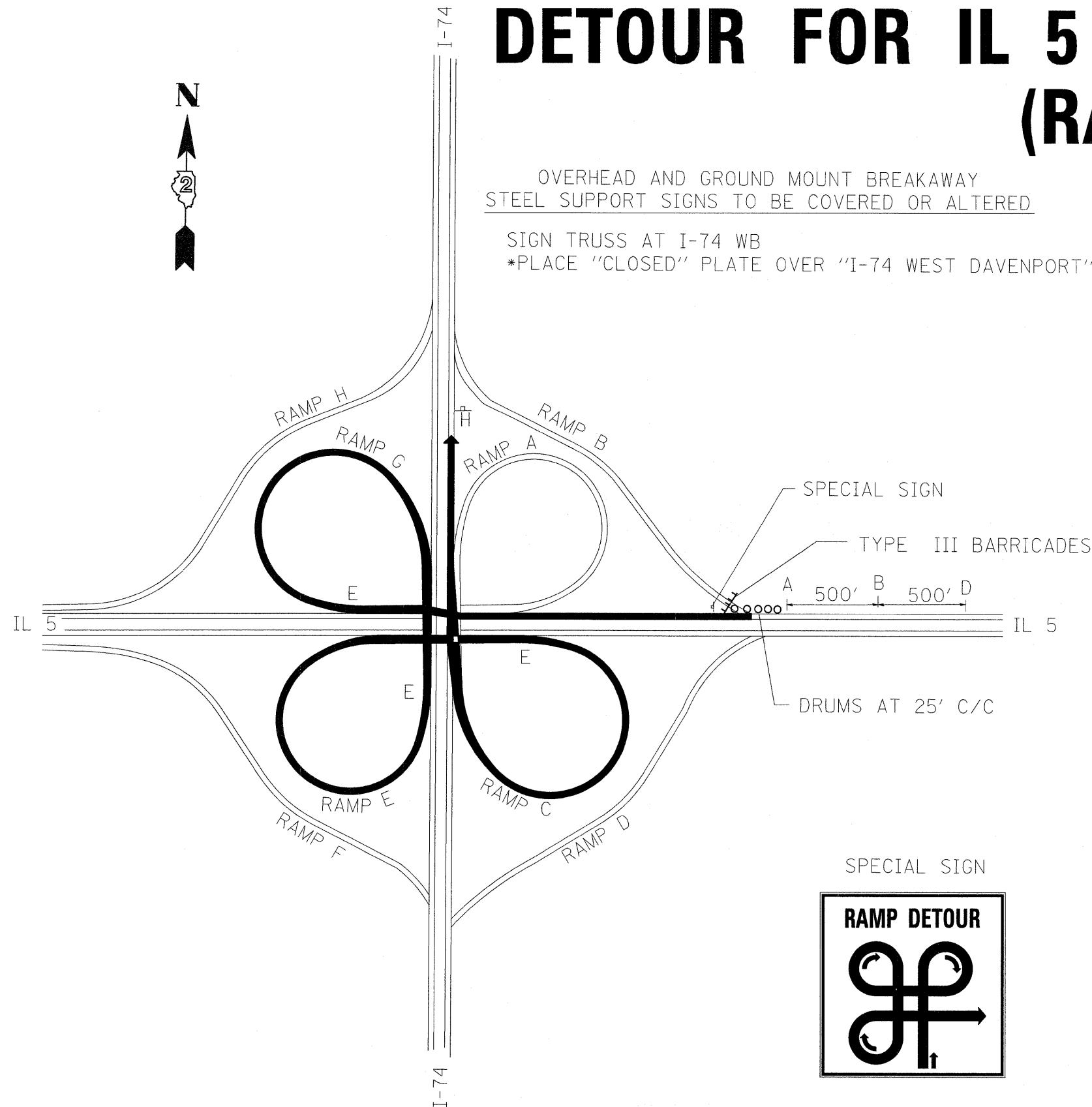

- A. **DETOUR** M4-8(0)(30x15)
- EAST** M3-2 30X15 BLUE
- 74** M1-1 36 RED, WHITE, BLUE
- ↑** M6-3 30X18 ORANGE
- B. **RAMP DETOUR AHEAD** 48"
- D. **RAMP CLOSED AHEAD** 48"
- H. **END DETOUR** M4-8A 24X18
- E. **DETOUR** M4-8(0)(30x15)
- EAST** M3-2 30X15 BLUE
- 74** M1-1 36 RED, WHITE, BLUE
- ↗** M6-2R 30X18 ORANGE

**RAMP CLOSED** 48X30 BLACK ON WHITE

NOTE: THE TYPE III BARRICADE SHALL HAVE A RAMP CLOSED SIGN. REVISE SIGN R11-2 (Road Closed) to "RAMP CLOSED"

THE CONTRACTOR SHALL BE RESPONSABLE FOR PROVIDING ALL SIGNS REQUIRED FOR THE RAMP CLOSURES AND DETOURS.

SEE SPECIAL SIGN DETAILS SHEET  
THE RAMP SHALL NOT BE CLOSED AT THE SAME TIME.

Powerdraft: special signs I74&IL5

FILE NAME =	USER NAME = duncanfa	DESIGNED -	REVISED -	<b>STATE OF ILLINOIS DEPARTMENT OF TRANSPORTATION</b>	<b>DETOUR FOR IL 5 WB TO I-74 WB</b>				F.A.1 RTE.	SECTION	COUNTY	TOTAL SHEETS	SHEET NO.
ca\pw_work\PWIDOT\DUNCANFA\dms33952\d0805-shd-ts.dgn		DRAWN -	REVISED -		505	*	ROCK ISLAND	246	106				
PLOT SCALE = 50.0000' / IN.		CHECKED -	REVISED -		CONTRACT NO. 64A97								
PLOT DATE = Fri, Feb 06 10:54:46 2009		DATE -	REVISED -		SCALE:	SHEET NO.	OF	SHEETS	STA.	TO STA.	ILLINOIS FED. AID PROJECT		

# DETOUR FOR I-74 EB(SB) TO IL 5 WB (RAMP H)

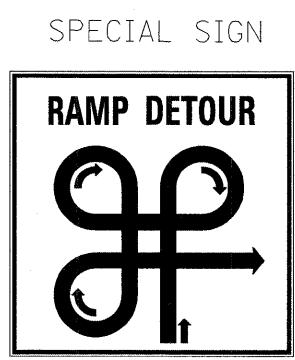
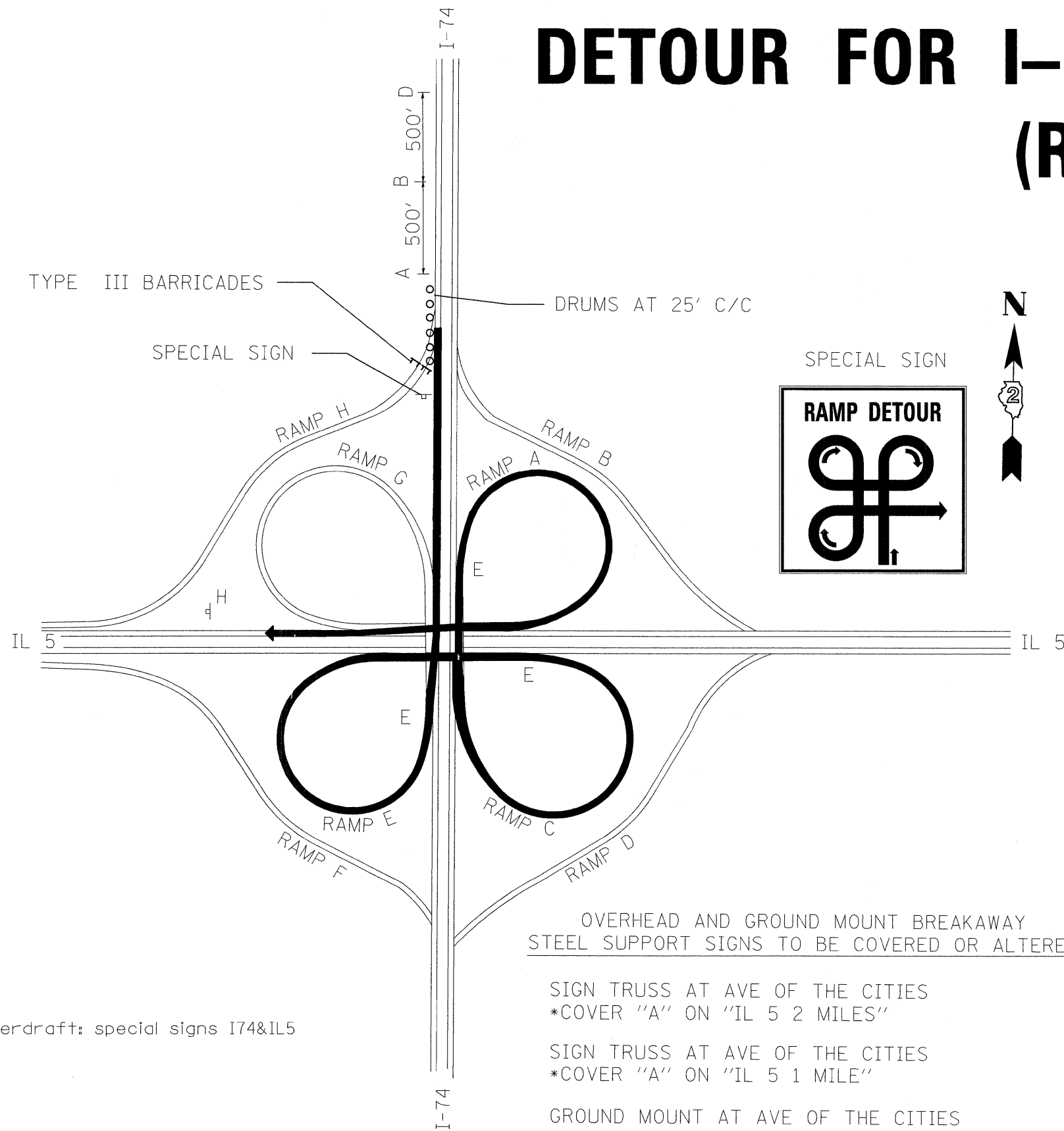

- A. **DETOUR** M4-8(0)(30x15)
- WEST** M3-4 30X15 WHITE
- ILLINOIS 5** M1-I100 36 WHITE
- ↑** M6-3 30X18 ORANGE
- B. **RAMP DETOUR AHEAD** 48"
- D. **RAMP CLOSED AHEAD** 48"
- H. **END DETOUR** M4-8A 24X18
- E. **DETOUR** M4-8(0)(30x15)
- WEST** M3-4 30X15 WHITE
- ILLINOIS 5** M1-I100 36 WHITE
- ↗** M6-2R 30X18 ORANGE

NOTE: THE TYPE III BARRICADE SHALL HAVE A RAMP CLOSED SIGN. REVISE SIGN R11-2 (Road Closed) to "RAMP CLOSED"

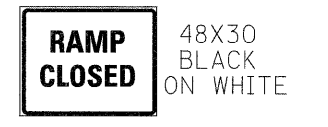

THE CONTRACTOR SHALL BE RESPONSIBLE FOR PROVIDING ALL SIGNS REQUIRED FOR THE RAMP CLOSURES AND DETOURS.

SEE SPECIAL SIGN DETAILS SHEET

THE RAMPS SHALL NOT BE CLOSED AT THE SAME TIME.

OVERHEAD AND GROUND MOUNT BREAKAWAY STEEL SUPPORT SIGNS TO BE COVERED OR ALTERED

- SIGN TRUSS AT AVE OF THE CITIES  
\*COVER "A" ON "IL 5 2 MILES"
- SIGN TRUSS AT AVE OF THE CITIES  
\*COVER "A" ON "IL 5 1 MILE"
- GROUND MOUNT AT AVE OF THE CITIES  
\*PLACE "CLOSED" PLATE OVER "IL 5 1/2 MILE"
- SIGN TRUSS AT IL 5 WB  
\*PLACE "CLOSED" PLATE OVER "IL 5 WEST" ↗

Powerdraft: special signs I74&IL5

CLOSE THIRD LANE USING 701422 FOR THIS RAMP CLOSURE



FILE NAME =	USER NAME = duncanfa	DESIGNED -	REVISED -	<b>STATE OF ILLINOIS DEPARTMENT OF TRANSPORTATION</b>	<b>DETOUR FOR I-74 EB TO IL 5 WB</b>				F.A.I. RTE.	SECTION	COUNTY	TOTAL SHEETS	SHEET NO.
ct\pw_work\PWIDOT\DUNCANFA\dms33952\vd8805-shr-ts.dgn	PLT SCALE = 50.0000' / IN.	DRAWN -	REVISED -						505	*	ROCK ISLAND	246	107
PLT DATE = Fri Feb 06 10:54:46 2009	DATE -	CHECKED -	REVISED -		CONTRACT NO. 64A97				ILLINOIS FED. AID PROJECT				
					SCALE:	SHEET NO.	OF	SHEETS	STA.	TO STA.	81-(1-2,1,2-2)RS-18M		

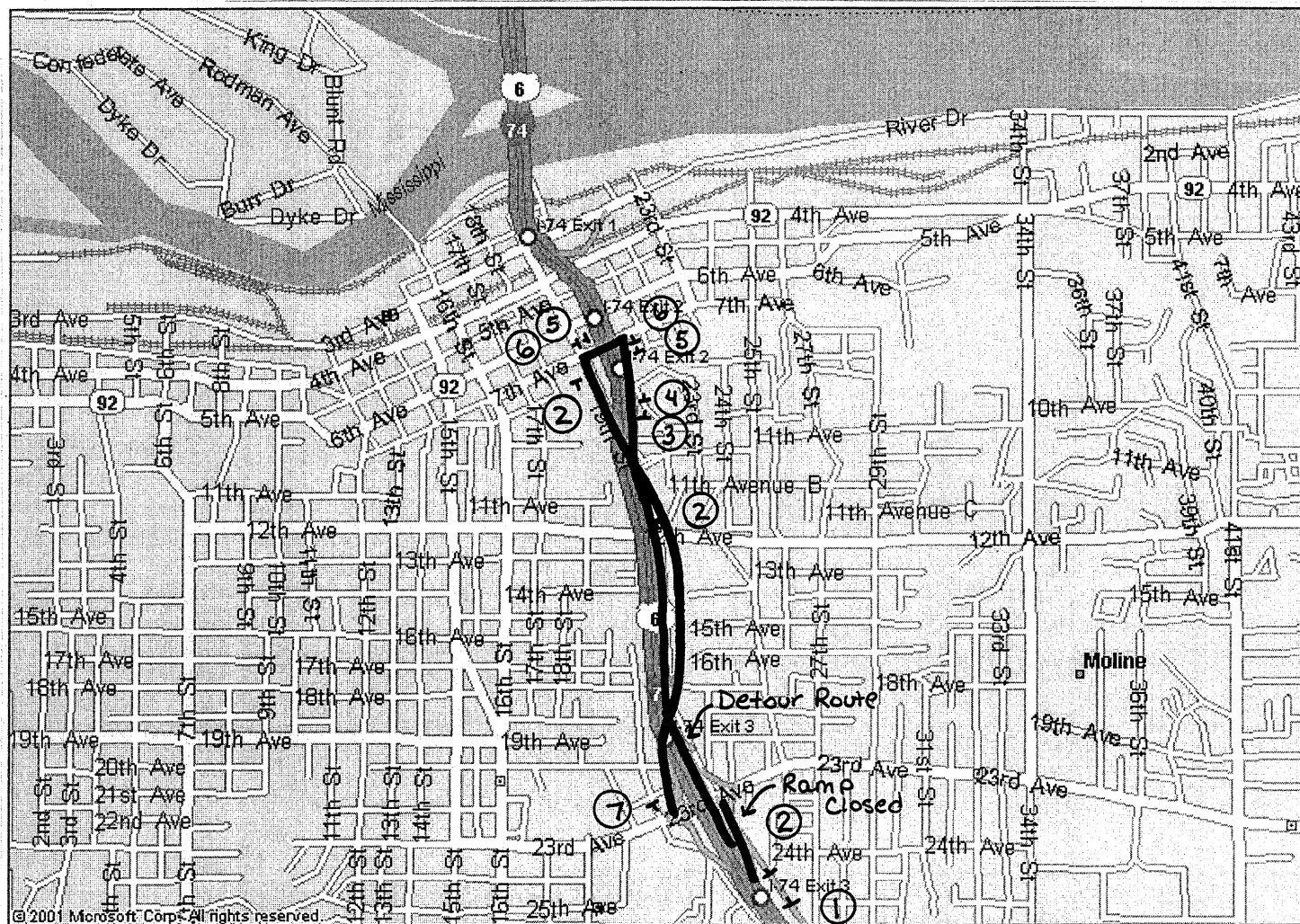

# DETOUR FOR I-74 WB(NB) TO AVENUE OF THE CITIES

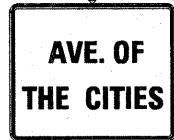
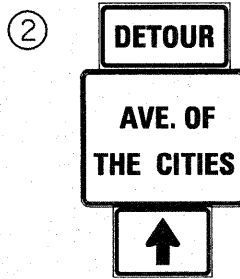
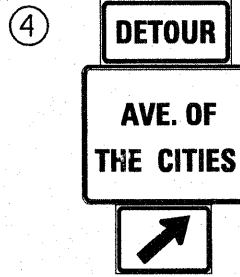
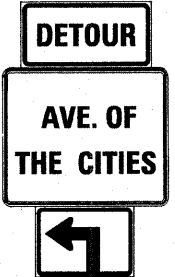
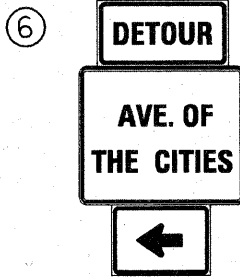

## SIGN LEGEND

- ①  W 20-2
- ②  36x30 ORANGE 6" LETTERS MIN.
- ③  M4-8(0)(30x15)  
36x30 ORANGE 6" LETTERS MIN.  
M6-3(0)(30x18)
- ④  M4-8(0)(30x15)  
36x30 ORANGE 6" LETTERS MIN.  
M5-2R(0)(30x18)
- ⑤  M4-8(0)(30x15)  
36x30 ORANGE 6" LETTERS MIN.  
M5-1L(0)(30x18)
- ⑥  M4-8(0)(30x15)  
36x30 ORANGE 6" LETTERS MIN.  
M6-2R(0)(30x18)
- ⑦  M4-8A (0) 2418

- NOTE: OVERHEAD AND GROUND MOUNT BREAKAWAY STEEL SUPPORT SIGNS TO BE COVERED OR ALTERED.
- SIGN TRUSS BETWEEN I-280 AND IL 5 COMPLETELY COVER (WITH TARP) "MOLINE NEXT 4 EXITS"
  - SIGN TRUSS AT IL 5 WB GORE PLACE "CLOSED" PLATE OVER "AVENUE OF THE CITIES 1 1/2 MILES"
  - GROUND MOUNT "AVENUE OF THE CITIES 1/2 MILE" PLACE "CLOSED" PLATE OVER SIGN
  - GROUND MOUNT AT AVENUE OF THE CITIES GORE PLACE "CLOSED" PLATE OVER SIGN

DETOUR ROUTE:  
CONTINUE NORTH ON I-74  
EXIT AT 7TH AVENUE  
WEST ON 7TH AVENUE  
SOUTH ON 19TH STREET





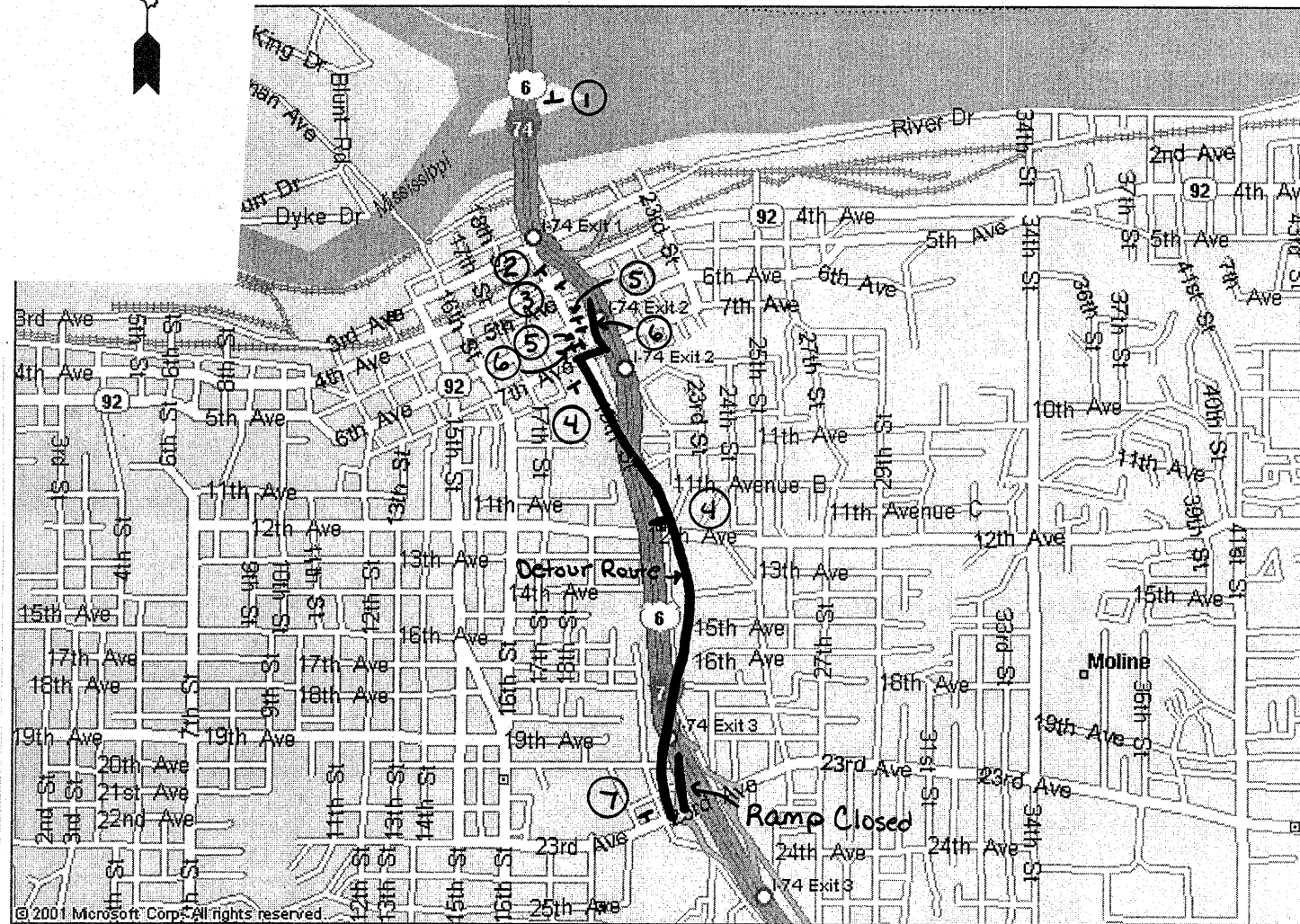

FILE NAME =	USER NAME = duncanfa	DESIGNED -	REVISED -	<b>STATE OF ILLINOIS DEPARTMENT OF TRANSPORTATION</b>	<b>DETOUR FOR I-74 WB TO AVE. OF THE CITIES</b>	F.A.I. RTE.	SECTION	COUNTY	TOTAL SHEETS	SHEET NO.	
c:\pwork\p\1001\QUNCANFA\dms33952\1001\805-ah-t-s.dgn	PLOT SCALE = 50.0000' / IN.	CHECKED -	REVISED -			505	*	ROCK ISLAND	246	108	
PLOT DATE = Fri Feb 06 10:54:48 2009	DATE -	REVISED -	REVISED -			ILLINOIS FED. AID PROJECT					
						CONTRACT NO. 64A97					





# DETOUR FOR I-74 EB(SB) TO AVENUE OF THE CITIES

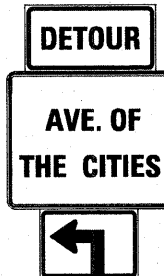

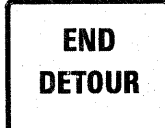
## SIGN LEGEND

- ①  W 20-2  
 36x30 ORANGE 6" LETTERS MIN.
- ②  M4-8(0)(30x15)  
36x30 ORANGE 6" LETTERS MIN.  
M5-2R(0)(30x18)
- ③  M4-8(0)(30x15)  
36x30 ORANGE 6" LETTERS MIN.  
M6-2R(0)(30x18)
- ④  M4-8(0)(30x15)  
36x30 ORANGE 6" LETTERS MIN.  
M6-3(0)(30x18)
- ⑤  M4-8(0)(30x15)  
36x30 ORANGE 6" LETTERS MIN.  
M5-1L(0)(30x18)
- ⑥  M4-8(0)(30x15)  
36x30 ORANGE 6" LETTERS MIN.  
M6-1L(0)(30x18)
- ⑦  M4-8A (0) 2418

NOTE: OVERHEAD AND GROUND MOUNT BREAKAWAY STEEL SUPPORT SIGNS TO BE COVERED OR ALTERED.

- SIGN TRUSS AT 7TH AVENUE GORE  
COVER "1 MILE" ON "AVENUE OF THE CITIES 1 MILE"  
INSTALL  8'x24" ORANGE IN LOWER LEFT CORNER OF THE SIGN
- CANTILEVER "AVENUE OF THE CITIES 1/2 MILE"  
PLACE "CLOSED" PLATE OVER SIGN
- SIGN TRUSS BETWEEN 7TH AVENUE AND AVENUE OF THE CITIES  
PLACE "CLOSED" PLATE OVER "AVENUE OF THE CITIES EXIT  ONLY"
- SIGN TRUSS AVENUE OF THE CITIES GORE  
PLACE "CLOSED" PLATE OVER "AVENUE OF THE CITIES  "

DETOUR ROUTE:  
7TH AVENUE OFF RAMP  
WEST ON 7TH AVENUE  
SOUTH ON 19TH STREET

FILE NAME =	USER NAME = duncanfo	DESIGNED -	REVISED -	<b>STATE OF ILLINOIS DEPARTMENT OF TRANSPORTATION</b>	<b>DETOUR FOR I-74 EB TO AVE. OF THE CITIES</b>				F.A.I. RTE.	SECTION	COUNTY	TOTAL SHEETS	SHEET NO.
ca:\pw\work\PIWIDOT\DUNCANFA\dms33952\10805-shr-tds.dgn	PLLOT SCALE = 50.0000' / IN.	DRAWN -	REVISED -						505	*	ROCK ISLAND	246	109
PLLOT DATE = Fri Feb 06 10:54:49 2009	DATE -	CHECKED -	REVISED -						CONTRACT NO. 64A97				
									ILLINOIS FED. AID PROJECT				

# DETOUR FOR IL 5 EB TO I-74 WB (NB)

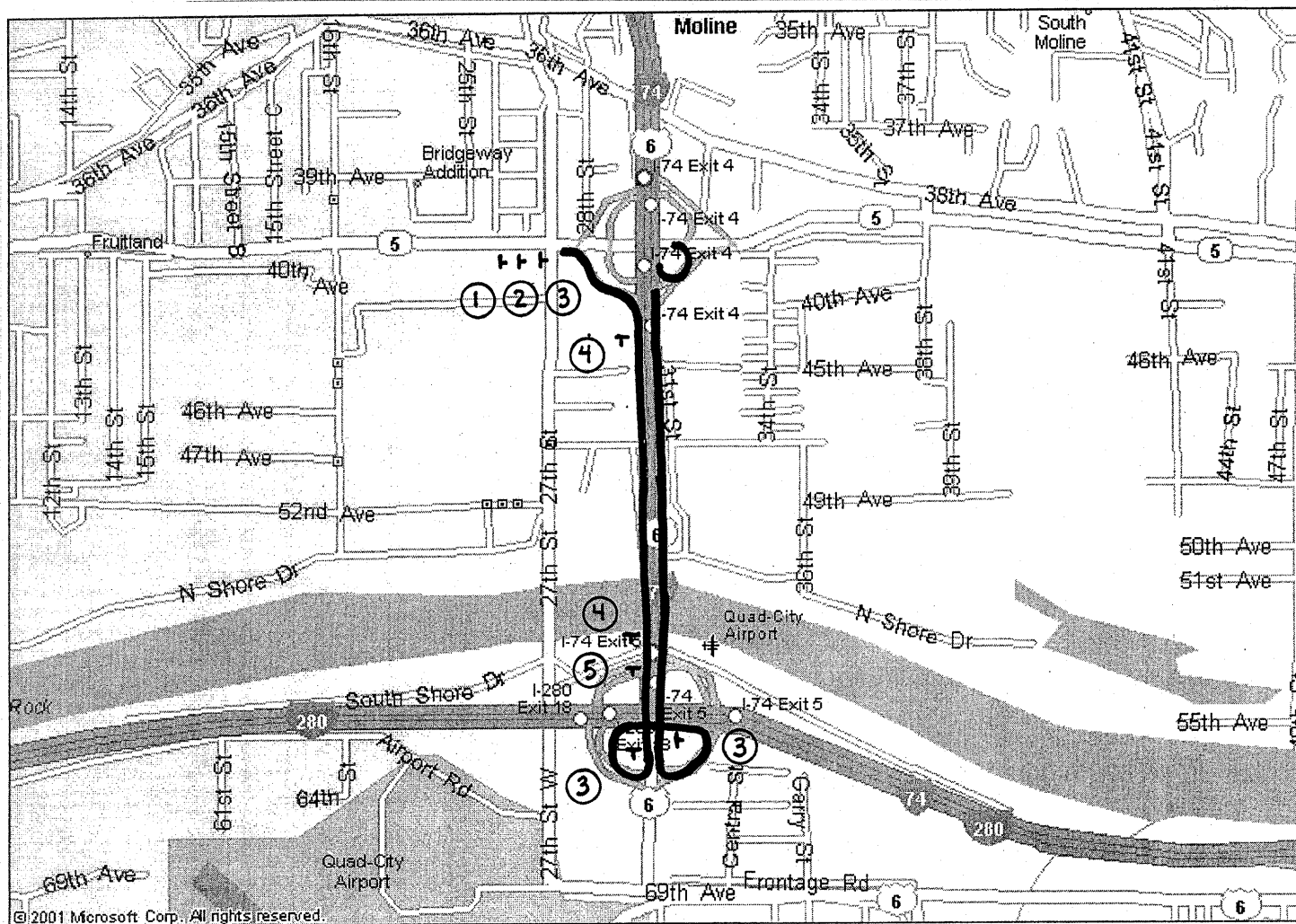

①

**RAMP  
DETOUR  
AHEAD** W 20-2 (48)

**WEST** M3-4  
30X15  
BLUE

**74** M1-1  
36  
RED, WHITE,  
BLUE

②

**DETOUR** M4-8(0)(30x15)

**WEST** M3-4  
30X15  
BLUE

**74** M1-1  
36  
RED, WHITE,  
BLUE

**↗** M5-2R(0)(30x18)

③

**DETOUR** M4-8(0)(30x15)

**WEST** M3-4  
30X15  
BLUE

**74** M1-1  
36  
RED, WHITE,  
BLUE

**↗** M6-2R  
30X18  
ORANGE

④

**DETOUR** M4-8(0)(30x15)

**WEST** M3-4  
30X15  
BLUE

**74** M1-1  
36  
RED, WHITE,  
BLUE

**↑** M6-3  
30X18  
ORANGE

⑤

**RAMP DETOUR**

SEE SPECIAL SIGN DESIGN

NOTE: OVERHEAD AND GROUND MOUNT BREAKAWAY STEEL SUPPORT SIGNS TO BE COVERED OR ALTERED.

-SIGN TRUSS AT I-74 EB (SB) GORE  
PLACE "CLOSED" PLATE OVER "I-74 WEST DAVENPORT NEXT RIGHT"









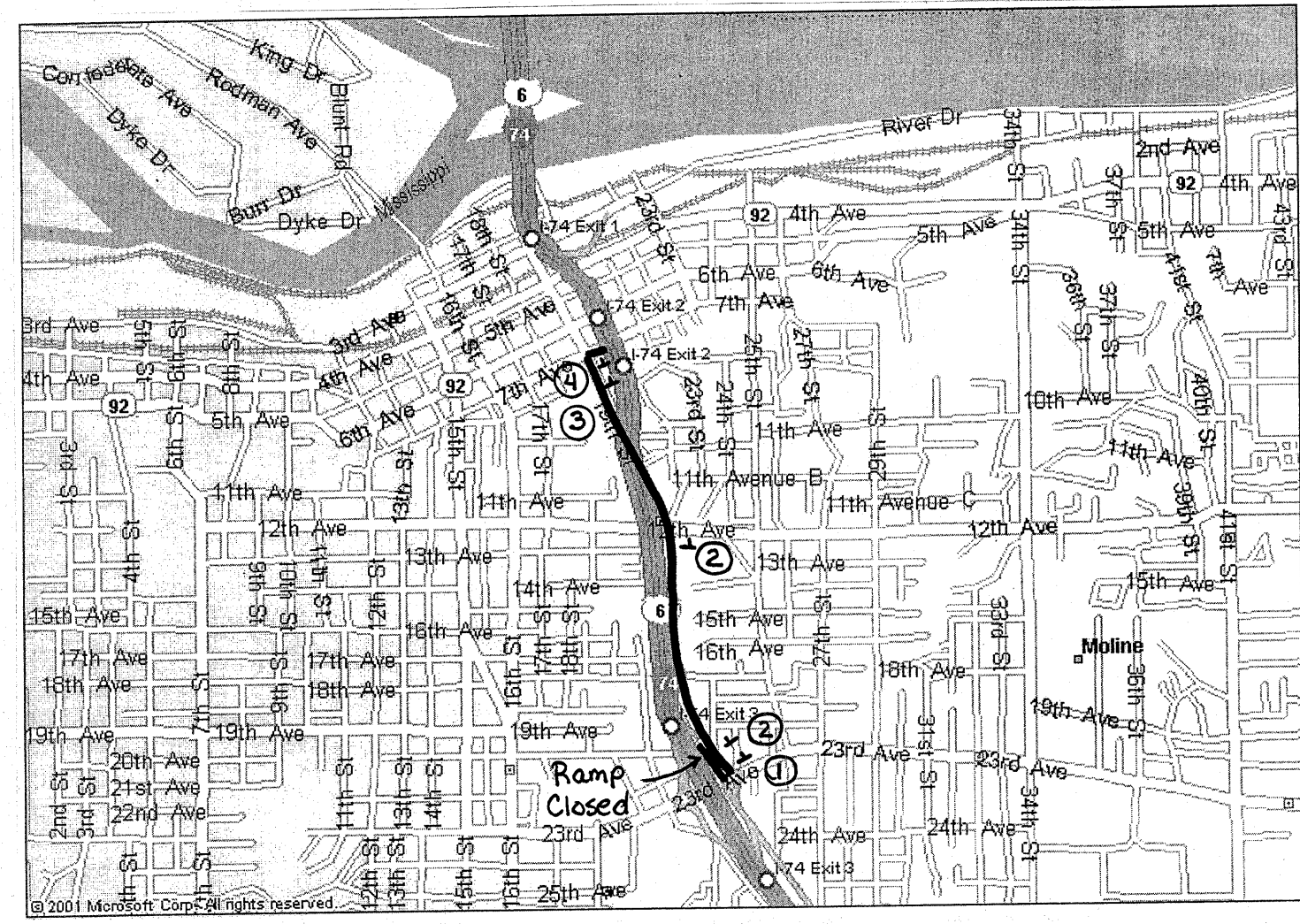

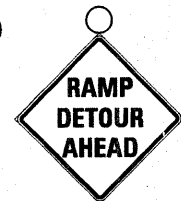



-CANTILEVER AT I-74 WB(NB) GORE  
PLACE "CLOSED" PLATE OVER SIGN

DETOUR ROUTE:  
SOUTH ON I-74  
TAKE 2 INSIDE RAMPS AT I-280

FILE NAME =	USER NAME = duncanfa	DESIGNED -	REVISED -	<b>STATE OF ILLINOIS DEPARTMENT OF TRANSPORTATION</b>	<b>DETOUR FOR IL 5 EB TO I-74 WB</b>				F.A.I. RTE. 505	SECTION *	COUNTY ROCK ISLAND	TOTAL SHEETS 246	SHEET NO. 110
ct:\pwork\PIWIDOT\DUNCANFA\dms33952\d06805-sht-ts.dgn	PLOT SCALE = 50.0000 / IN.	DRAWN -	REVISED -						SCALE: SHEET NO. OF SHEETS STA. TO STA.				ILLINOIS FED. AID PROJECT CONTRACT NO. 64A97
	PLOT DATE = Fri Feb 06 10:54:49 2009	CHECKED -	REVISED -						• 81-11-2,1,2-21RS-1&M				
		DATE -	REVISED -										

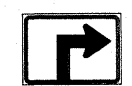
# DETOUR FOR AVENUE OF THE CITIES TO I-74 WB(NB)

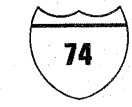

- ①  W 20-2 (48)
-  M3-4 30X15 BLUE
-  M1-1 36 RED, WHITE, BLUE
- ②  M4-8(0)(30x15)
-  M3-4 30X15 BLUE
-  M1-1 36 RED, WHITE, BLUE
-  M6-3 30X18 ORANGE
- ③  M4-8(0)(30x15)
-  M3-4 30X15 BLUE
-  M1-1 36 RED, WHITE, BLUE
-  M5-1R(0)(30x18)
- ④  M4-8(0)(30x15)
-  M3-4 30X15 BLUE
-  M1-1 36 RED, WHITE, BLUE
-  M6-1R(0)(30x18)

NOTE: OVERHEAD AND GROUND MOUNT BREAKAWAY STEEL SUPPORT SIGNS TO BE COVERED OR ALTERED.  
 - GROUND MOUNT AT I-74 WB (NB) GORE PLACE "CLOSED" PLATE OVER SIGN

DETOUR ROUTE:  
 NORTH ON 19TH STREET TO 7TH STREET  
 EAST ON 7TH STREET









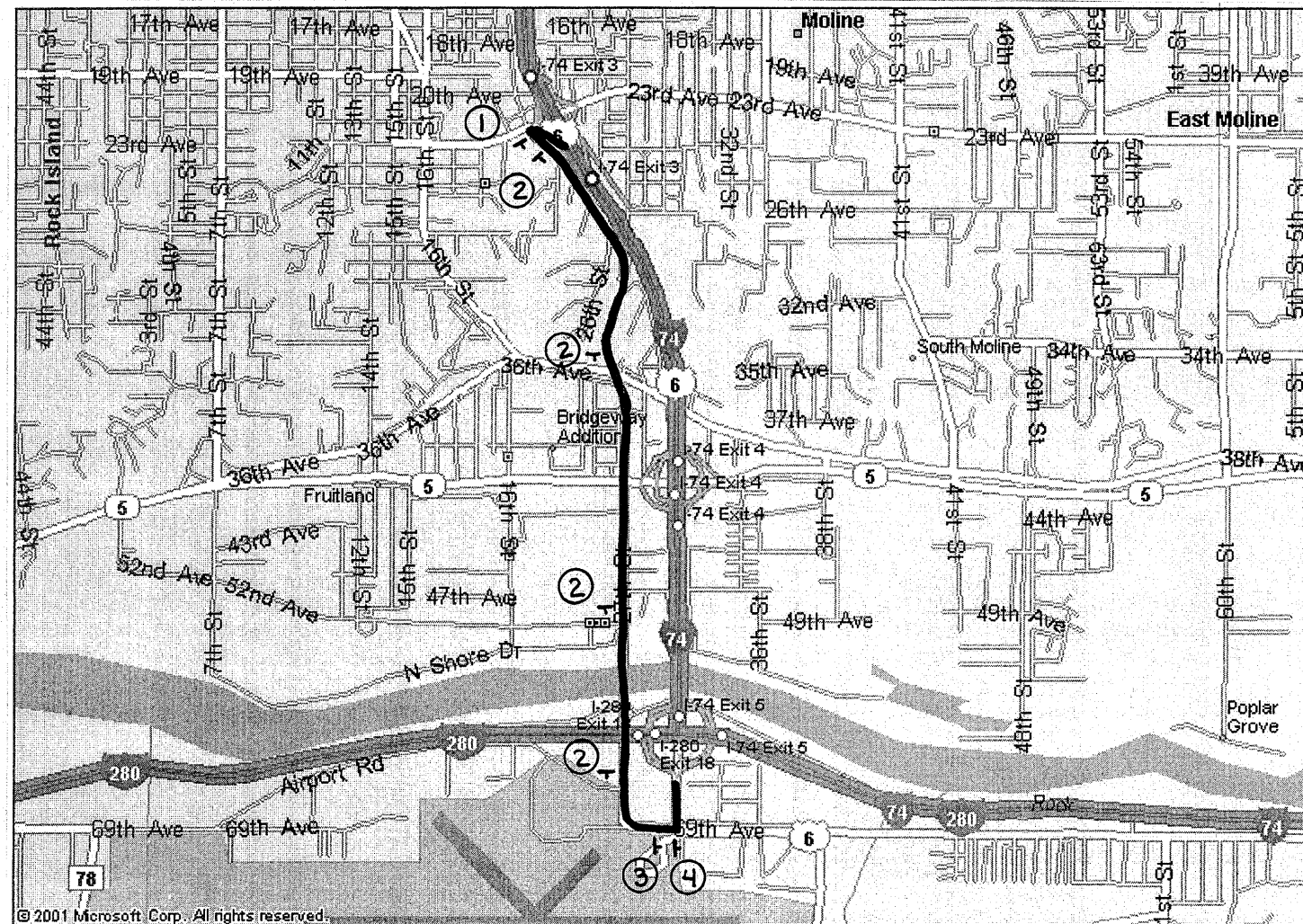





FILE NAME =	USER NAME = duncanfo	DESIGNED -	REVISED -	<b>STATE OF ILLINOIS DEPARTMENT OF TRANSPORTATION</b>	<b>DETOUR FOR AVE. OF THE CITIES TO I-74 WB</b>	F.A.I. RTE.	SECTION	COUNTY	TOTAL SHEETS	SHEET NO.	
ct:\pwork\PIWIDOT\DUNCANFA\dms33952\d08805-shr-ts.dgn		DRAWN -	REVISED -			505	*	ROCK ISLAND	246	111	
PLOT SCALE = 50,0000' / IN.		CHECKED -	REVISED -			CONTRACT NO. 64A97					
PLOT DATE = Fri Feb 06 10:54:51 2009		DATE -	REVISED -			ILLINOIS FED. AID PROJECT					
						81-(1-2,1,2-2)RS-1&M					

# DETOUR FOR AVENUE OF THE CITIES TO I-74 EB (SB)



## SIGN LEGEND



- |   |   |
|---|---|
| <p>①  W 20-2 (48)</p> <p> M3-2<br/>30X15<br/>BLUE</p> <p> M1-1<br/>36<br/>RED, WHITE,<br/>BLUE</p>   | <p>②  M4-8(O)(30X15)</p> <p> M3-2<br/>30X15<br/>BLUE</p> <p> M1-1<br/>36<br/>RED, WHITE,<br/>BLUE</p> <p> M6-3<br/>30X18<br/>ORANGE</p> |
| <p>③  M4-8(O)(30X15)</p> <p> M3-2<br/>30X15<br/>BLUE</p> <p> M1-1<br/>36<br/>RED, WHITE,<br/>BLUE</p> <p> M5-1L(O)(30X18)</p> | <p>④  M4-8(O)(30X15)</p> <p> M3-2<br/>30X15<br/>BLUE</p> <p> M1-1<br/>36<br/>RED, WHITE,<br/>BLUE</p> <p> M6-1L(O)(30X18)</p>   |

NOTE: OVERHEAD AND GROUND MOUNT BREAKAWAY STEEL SUPPORT SIGNS TO BE COVERED OR ALTERED.  
 - GROUND MOUNT AT I-74 EB (SB) GORE PLACE "CLOSED" PLATE OVER SIGN

DETOUR ROUTE:  
 SOUTH ON 19TH ST.  
 WHICH TURNS INTO 27TH ST.  
 WHICH TURNS INTO 69TH AVE.  
 NORTH ON I-74 STUB

FILE NAME =	USER NAME = duncanfa	DESIGNED -	REVISED -	<b>STATE OF ILLINOIS DEPARTMENT OF TRANSPORTATION</b>	<b>DETOUR FOR AVE. OF THE CITIES TO I-74 EB</b>	F.A.I. RTE. 505	SECTION *	COUNTY ROCK ISLAND	TOTAL SHEETS 246	SHEET NO. 112
ct:\pw_work\PWIDOT\DUNCANFA\dms33952\d08805-sht-ts.dgn		DRAWN -	REVISED -		SCALE:			CONTRACT NO. 64A97		
	PLOT SCALE = 50.0000' / IN.	CHECKED -	REVISED -		SHEET NO. OF SHEETS STA. TO STA.			ILLINOIS FED. AID PROJECT		
	PLOT DATE = Fri Feb 06 10:54:51 2009	DATE -	REVISED -							

# DETOUR FOR I-74 EB (SB) TO IL 5 EB

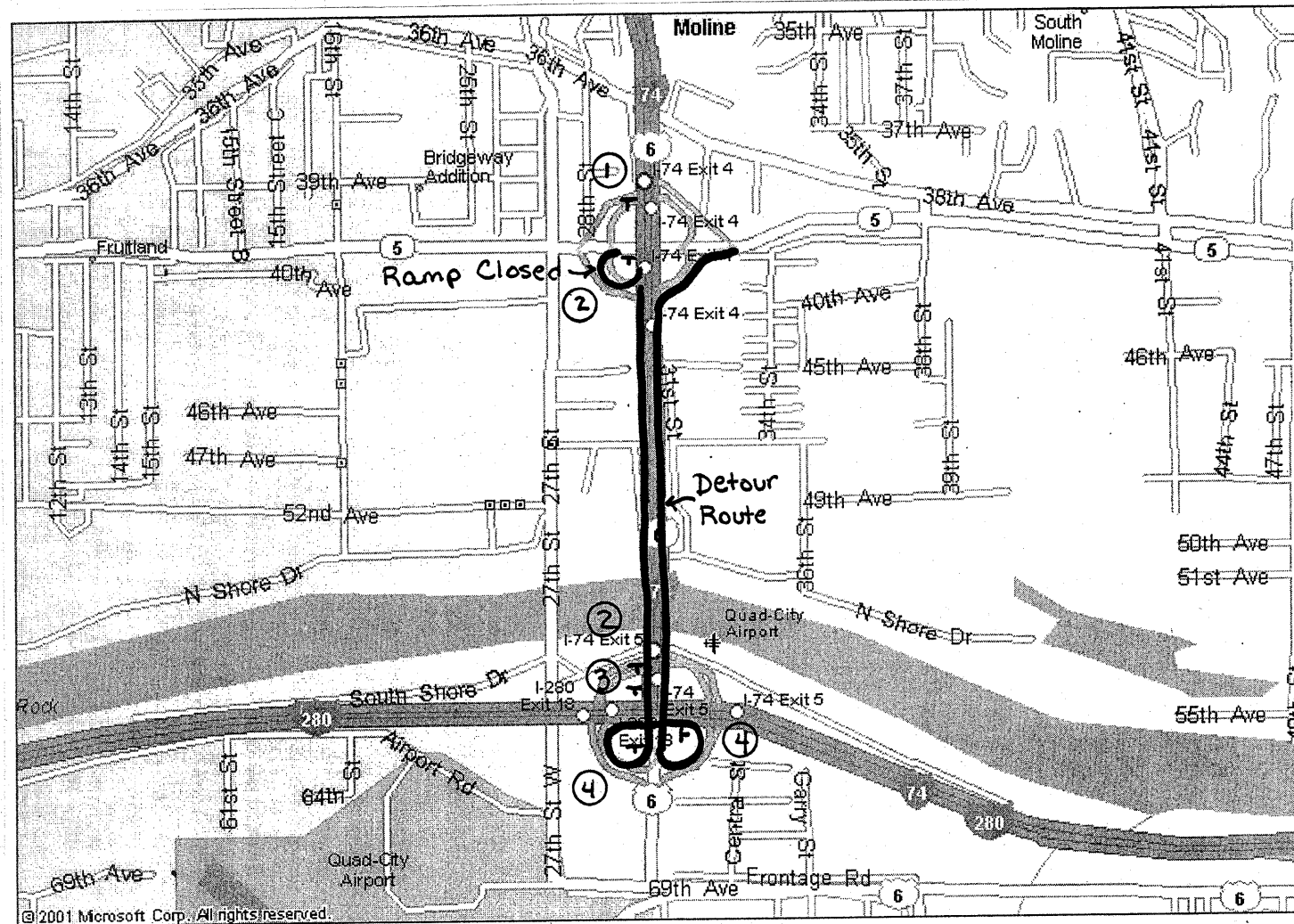

## SIGN LEGEND

- ①
- W 20-2
- M3-2 30X15 WHITE
- M1-I100 36 WHITE
- ②
- M4-8(0)(30x15)
- M3-2 30X15 WHITE
- M1-I100 36 WHITE
- M6-3 30X18 ORANGE
- ③
- SEE SPECIAL SIGN DESIGN
- ④
- M4-8(0)(30x15)
- M3-2 30X15 WHITE
- M1-I100 36 WHITE
- M6-2R 30X18 ORANGE

NOTE: OVERHEAD AND GROUND MOUNT BREAKAWAY STEEL SUPPORT SIGNS TO BE COVERED OR ALTERED.

-SIGN TRUSS AT AVENUE OF THE CITIES GORE  
COVER THE "B" ON THE IL 5 2 MILES" SIGN

-SIGN TRUSS "IL 5 1 MILE" SIGN  
COVER THE "B"

-SIGN TRUSS AT IL 5 WB GORE  
PLACE "CLOSED" PLATE OVER "IL 5 EAST NEXT RIGHT" SIGN

-CANTILEER AT IL 5 EB GORE  
PLACE "CLOSED" PLATE OVER SIGN

DETOUR ROUTE:  
CONTINUE SOUTH ON I-74  
TAKE 2 INSIDE LOOPS TO I-280  
NORTH ON I-74









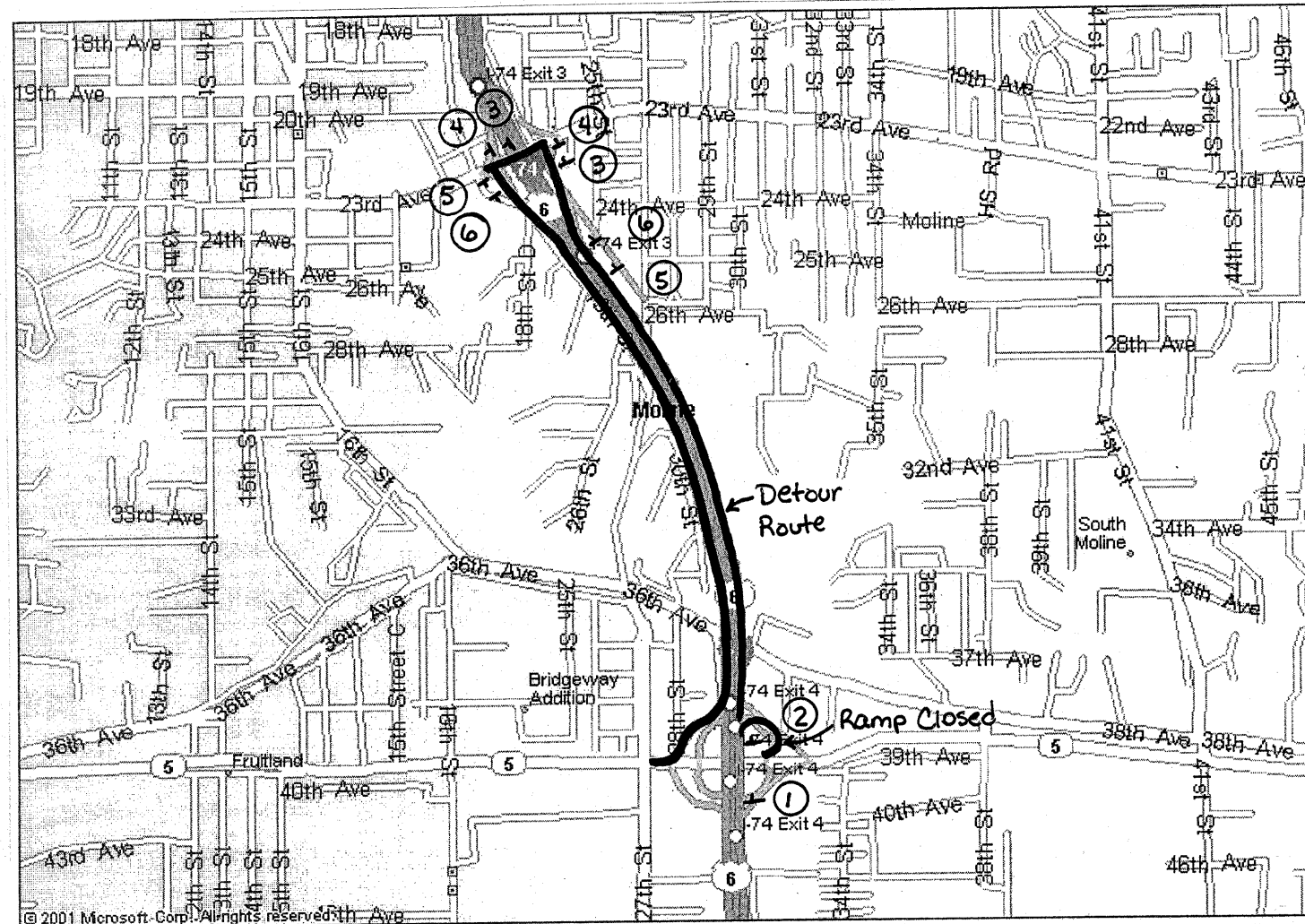



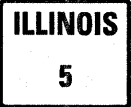

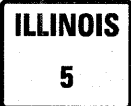



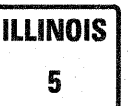

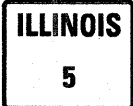

FILE NAME =	USER NAME = duncanfa	DESIGNED -	REVISED -	<b>STATE OF ILLINOIS DEPARTMENT OF TRANSPORTATION</b>	<b>DETOUR FOR I-74 EB TO IL 5 EB</b>	F.A.I. RTE.	SECTION	COUNTY	TOTAL SHEETS	SHEET NO.
ci:\pwork\PIWIDOT\DUNCANFA\dms33952\dms33952-shr-ts.dgn	DRAWN -	REVISED -	505			*	ROCK ISLAND	246	113	
PLOT SCALE = 50.0000' / IN.	CHECKED -	REVISED -	CONTRACT NO. 64A97							
PLOT DATE = Fri Feb 06 10:54:51 2009	DATE -	REVISED -	ILLINOIS FED. AID PROJECT							
						SCALE:	SHEET NO.	OF SHEETS	STA.	TO STA.

# DETOUR FOR I-74 WB (NB) TO IL 5 WB

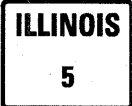

## SIGN LEGEND



<p>①  W 20-2 (48)</p> <p> M3-4 30X15 WHITE</p> <p> M1-I100 36 WHITE</p>	<p>②  M4-8(0)(30x15)</p> <p> M3-4 30X15 WHITE</p> <p> M1-I100 36 WHITE</p> <p> M6-3 30X18 ORANGE</p>	<p>③  M4-8(0)(30x15)</p> <p> M3-4 30X15 WHITE</p> <p> M1-I100 36 WHITE</p> <p> M5-1L(0)(30x18)</p>
<p>④  M4-8(0)(30x15)</p> <p> M3-4 30X15 WHITE</p> <p> M1-I100 36 WHITE</p> <p> M6-1L 30X18 ORANGE</p>	<p>⑤  M4-8(0)(30x15)</p> <p> M3-4 30X15 WHITE</p> <p> M1-I100 36 WHITE</p> <p> M5-2R(0)(30x18)</p>	<p>⑥  M4-8(0)(30x15)</p> <p> M3-4 30X15 WHITE</p> <p> M1-I100 36 WHITE</p> <p> M6-2R 30X18 ORANGE</p>









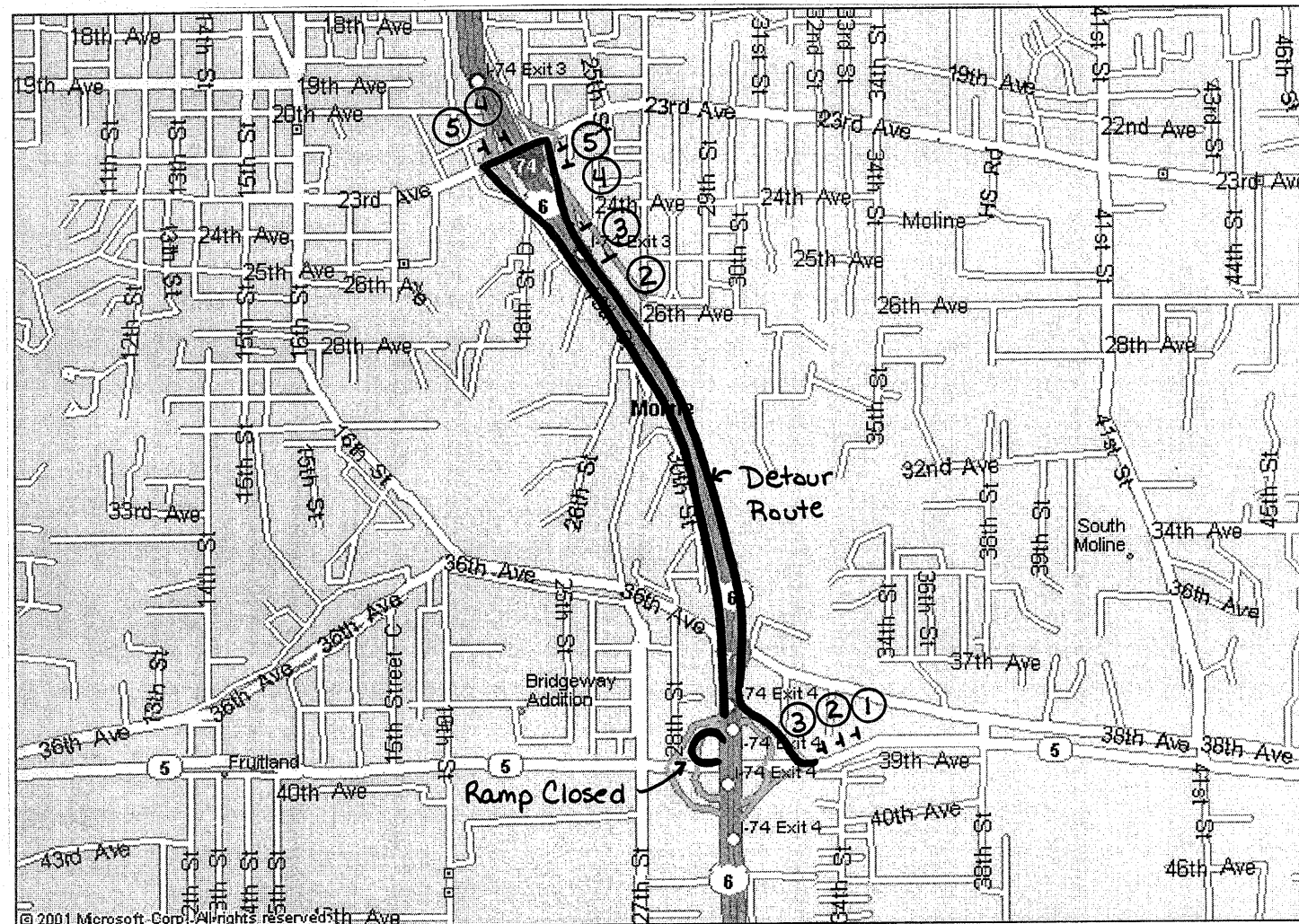





- NOTE: OVERHEAD AND GROUND MOUNT BREAKAWAY STEEL SUPPORT SIGNS TO BE COVERED OR ALTERED.
- SIGN TRUSS BETWEEN I-280 AND IL 5 COMPLETELY COVER (WITH TARP) "MOLINE NEXT 4 EXITS"
  - GROUND MOUNT FOR COLLEGES COVER THE BOTTOM HALF OF SIGN "AUGUSTANA COLLEGE EXIT 4A"
  - SIGN TRUSS AT IL 5 EB PLACE "CLOSED" PLATE OVER "IL 5 WEST NEXT RIGHT" SIGN
  - CANTILEER AT IL 5 WB PLACE "CLOSED" PLATE OVER SIGN

DETOUR ROUTE:  
CONTINUE NORTH ON I-74  
EXIT AT AVE. OF THE CITIES  
WEST ON AVE. OF THE CITIES  
SOUTH ON I-74

FILE NAME =	USER NAME = duncanfa	DESIGNED -	REVISED -	<b>STATE OF ILLINOIS DEPARTMENT OF TRANSPORTATION</b>	<b>DETOUR FOR I-74 WB TO IL 5 WB</b>			F.A.I. RTE. 505	SECTION *	COUNTY ROCK ISLAND	TOTAL SHEETS 246	SHEET NO. 114
ct:\pwork\FWIDOT\DUNCANFA\dms33952\d016805-sht-ts.dgn		DRAWN -	REVISED -		SCALE:	SHEET NO. OF	SHEETS	STA. TO STA.	CONTRACT NO. 64A97			
		CHECKED -	REVISED -		ILLINOIS FED. AID PROJECT							
		PLOT DATE = Fri Feb 06 10:54:53 2009	DATE -		81-11-2.1.2-2RS-1&M							

# DETOUR FOR IL 5 WB TO I-74 EB (SB)

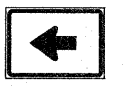

- ①  W 20-2 (48)
- ②  M4-8(0)(30x15)
- ③  M3-4 30x15 BLUE
- ④  M3-2 30x15 WHITE
- ⑤  M3-2 30x15 BLUE
- ①  M1-1 36 RED, WHITE, BLUE
- ②  M1-1 36 RED, WHITE, BLUE
- ③  M1-1 36 RED, WHITE, BLUE
- ④  M1-1 36 RED, WHITE, BLUE
- ⑤  M1-1 36 RED, WHITE, BLUE
- ①  M5-2R(0)(30x18)
- ②  M5-2R(0)(30x18)
- ③  M6-2R 30x18 ORANGE
- ④  M5-1L(0)(30x18)
- ⑤  M6-1L(0)(30x18)

NOTE: OVERHEAD AND GROUND MOUNT BREAKAWAY STEEL SUPPORT SIGNS TO BE COVERED OR ALTERED.

-CANTILEVER AT I-74 EB GORE  
PLACE "CLOSED" PLATE OVER SIGN

-SIGN TRUSS AT I-74 WB GORE  
"QUAD CITY AIRPORT", COMPLETELY COVER (WITH TARP) SIGN  
ON THE "I-74 EAST NEXT RIGHT" PLACE "CLOSED" PLATE OVER SIGN

DETOUR ROUTE:  
NORTH ON I-74  
EXIT AT AVENUE OF THE CITIES  
WEST ON AVENUE OF THE CITIES  
SOUTH OF I-74

FILE NAME =	USER NAME = duncanfa	DESIGNED -	REVISED -	<b>STATE OF ILLINOIS DEPARTMENT OF TRANSPORTATION</b>	<b>DETOUR FOR IL 5 WB TO I-74 EB</b>				F.A.T. RTE.	SECTION	COUNTY	TOTAL SHEETS	SHEET NO.
ci:\pw_work\PWIDOT\DUNCANFA\dms33952\0805-shr-ts.dgn		DRAWN -	REVISED -						505	*	ROCK ISLAND	246	1/5
PLOT SCALE = 50,0000' / IN.		CHECKED -	REVISED -						CONTRACT NO. 64A97				
PLOT DATE = Fri Feb 06 10:54:54 2009		DATE -	REVISED -						ILLINOIS FED. AID PROJECT 81-1-2,1,2-2IRS-1&M				

# PAVEMENT MARKING DETAILS

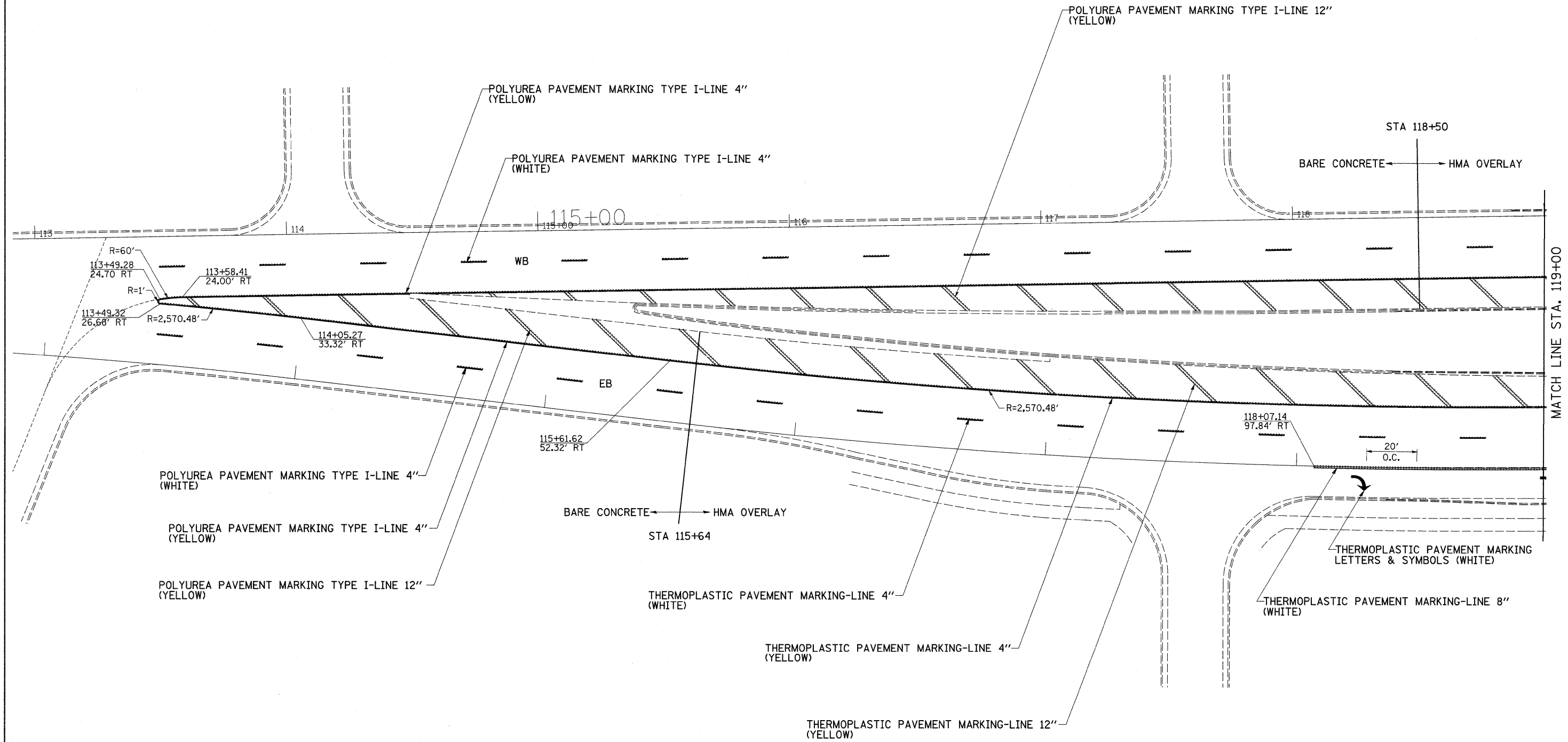
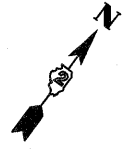

FILE NAME =	USER NAME = duncanfo	DESIGNED -	REVISED -	<b>STATE OF ILLINOIS DEPARTMENT OF TRANSPORTATION</b>	<b>PAVEMENT MARKING DETAILS</b>				F.A. RTE.	SECTION	COUNTY	TOTAL SHEETS	SHEET NO.
ct:\pw_work\PWIDOT\DUNCANFA\dms33952\dms33952-shr-pmk.dgn	DRAWN -	REVISED -	REVISED -									246	116
PLOT SCALE = 20,000' / IN.	CHECKED -	REVISED -	REVISED -		SCALE:	SHEET NO.	OF SHEETS	STA.	TO STA.	CONTRACT NO.			
PLOT DATE = Fri Feb 06 11:01:42 2009	DATE -	REVISED -	REVISED -		ILLINOIS FED. AID PROJECT								



# PAVEMENT MARKING DETAILS

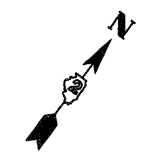

MATCH LINE STA. 119+00

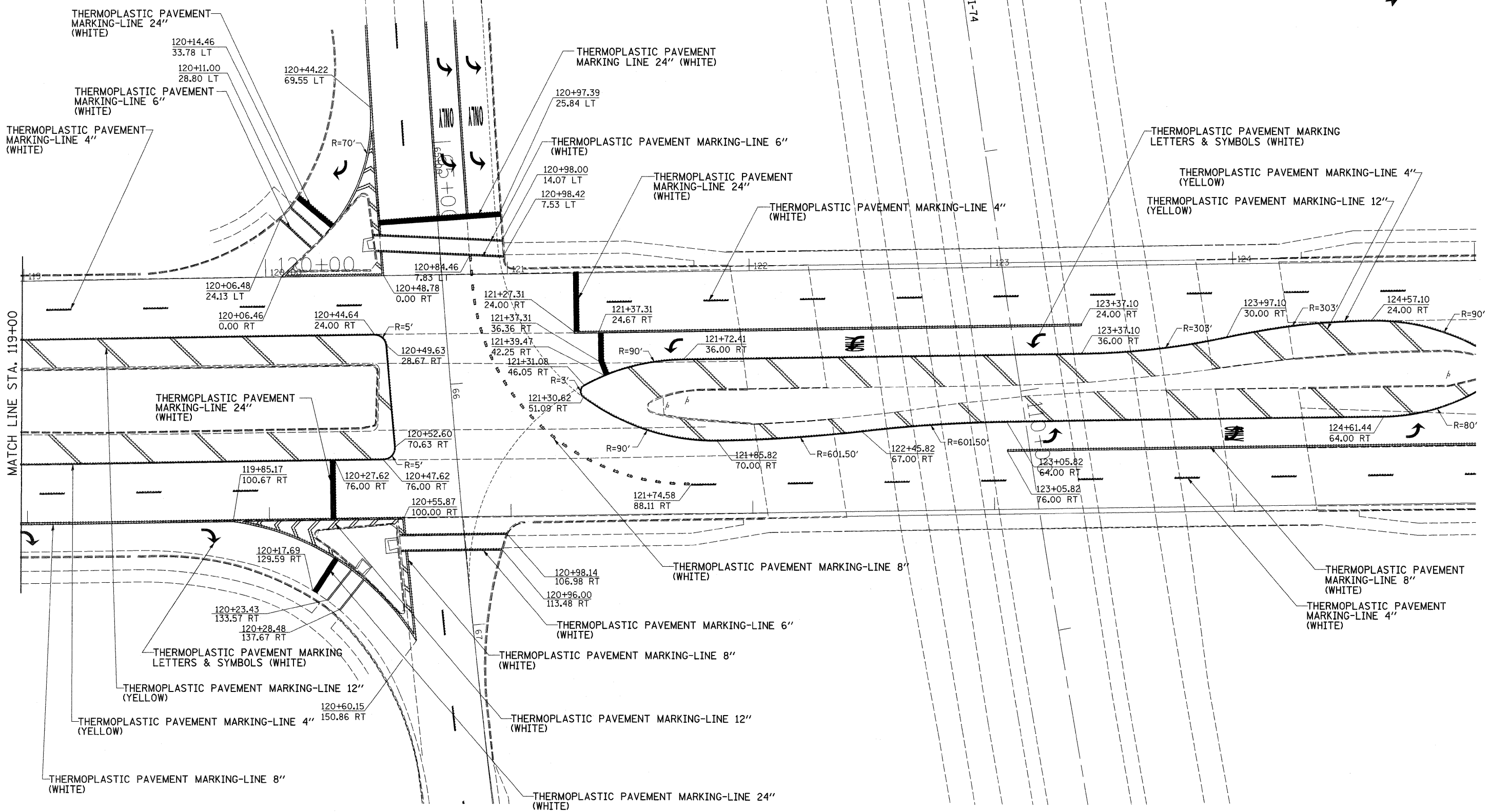

FILE NAME =	USER NAME = dunoanfa	DESIGNED -	REVISED -
ca\pwork\PWIDOT\DUNCANFA\dms33952\0805-shit-pmk.dgn		DRAWN -	REVISED -
	PLOT SCALE = 20.0000' / IN.	CHECKED -	REVISED -
	PLOT DATE = Fri Feb 06 11:01:43 2009	DATE -	REVISED -

**STATE OF ILLINOIS  
DEPARTMENT OF TRANSPORTATION**

**PAVEMENT MARKING DETAILS**

SCALE: SHEET NO. OF SHEETS STA. TO STA.

F.A. RTE.	SECTION	COUNTY	TOTAL SHEETS	SHEET NO.
			246	117
CONTRACT NO.				
ILLINOIS FED. AID PROJECT				

# PAVEMENT MARKING DETAILS

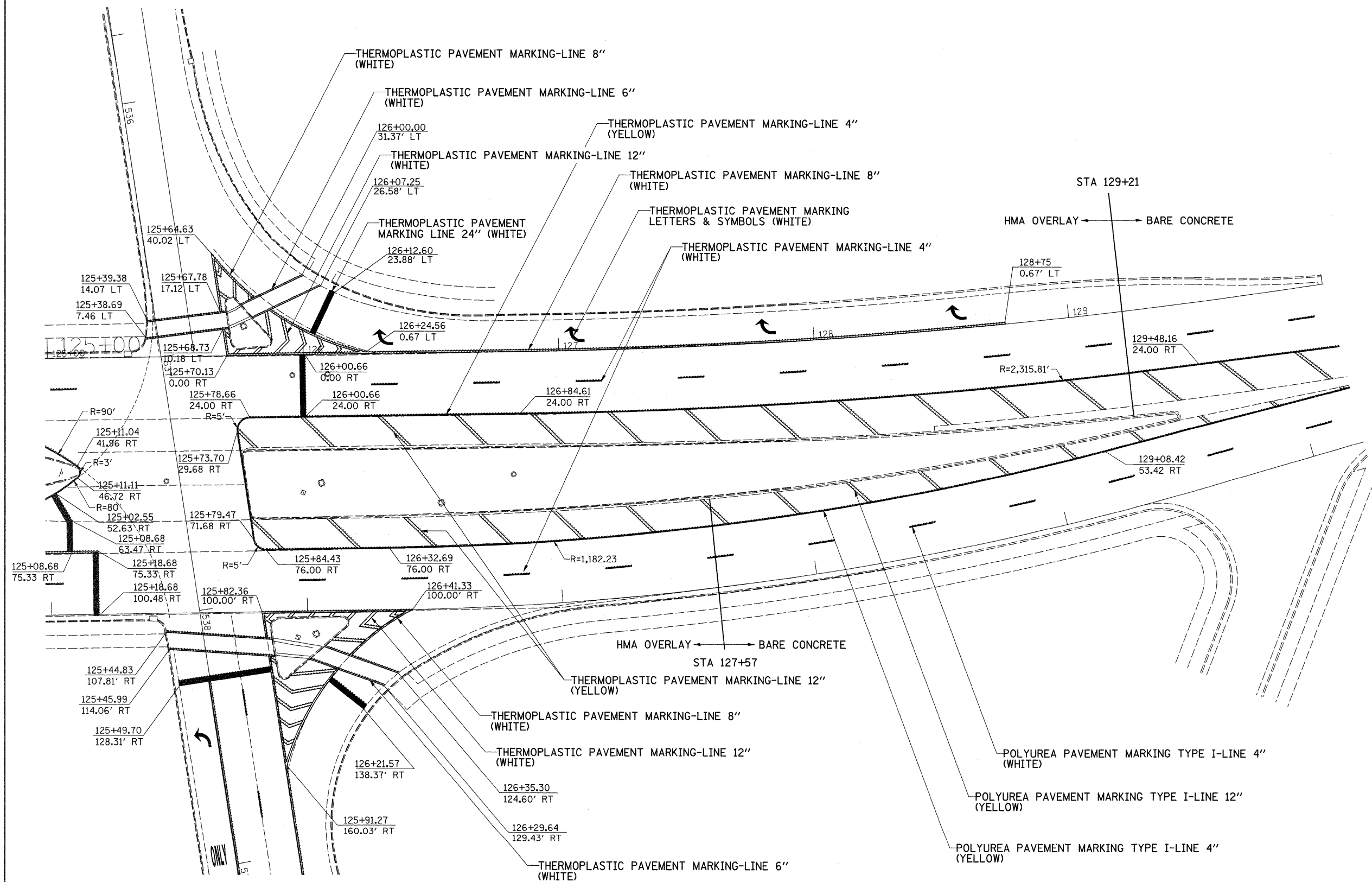
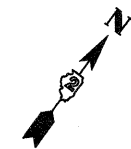

FILE NAME =	USER NAME = dunoanfa	DESIGNED -	REVISED -	<b>STATE OF ILLINOIS DEPARTMENT OF TRANSPORTATION</b>	<b>PAVEMENT MARKING DETAILS</b>				F.A. RTE.	SECTION	COUNTY	TOTAL SHEETS	SHEET NO.
cd:\pw\work\PWIDOT\DUNCANFA\dms33952\0805-shit-pmk.dgn		DRAWN -	REVISED -		SCALE:	SHEET NO.	OF	SHEETS	STA.	TO STA.		246	118
		CHECKED -	REVISED -								CONTRACT NO.		
		DATE	REVISED -								ILLINOIS FED. AID PROJECT		

# PAVEMENT MARKING DETAILS

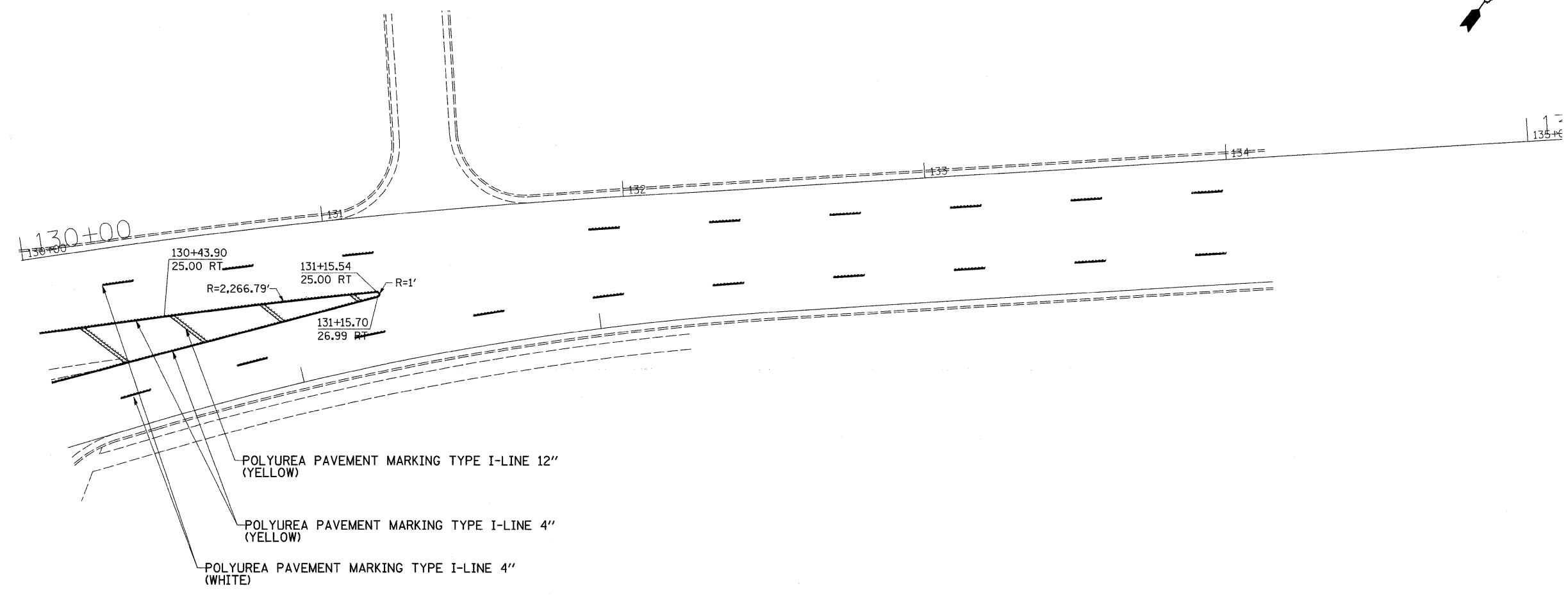
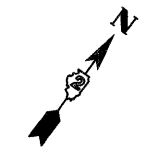

FILE NAME =	USER NAME = duncanfa	DESIGNED -	REVISED -	<b>STATE OF ILLINOIS DEPARTMENT OF TRANSPORTATION</b>	<b>PAVEMENT MARKING DETAILS</b>				F.A. RTE.	SECTION	COUNTY	TOTAL SHEETS	SHEET NO.
ct:\pw_work\PWIDOT\DUNCANFA\dms33952\d0805-shr-pmk.dgn		DRAWN -	REVISED -									246	119
PLOT SCALE = 20,0000' / IN.		CHECKED -	REVISED -		SCALE:	SHEET NO.	OF	SHEETS	STA.	TO STA.	CONTRACT NO.		
PLOT DATE = Fri Feb 06 11:01:46 2009		DATE -	REVISED -		ILLINOIS FED. AID PROJECT								

# SLOTTED DRAINS TO BE ADJUSTED

LT STA 201 + 47.64 – 202 + 58.35

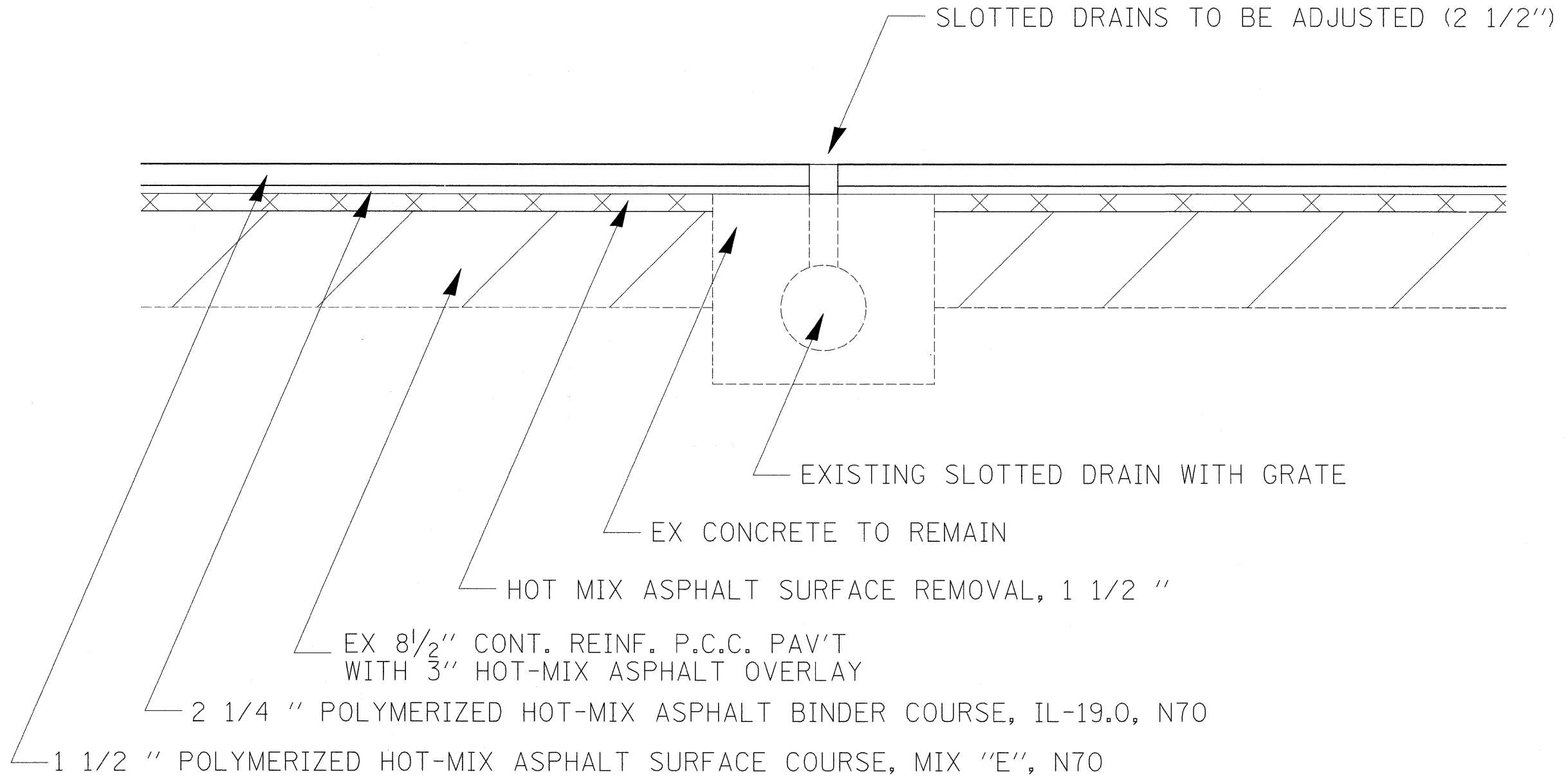

**NOTES:**

A 2 1/2" galvanized grate extension shall be welded to the existing slotted drain grate according to the manufacturer's requirements. The grate shall conform to District Standard 61.2. If the existing slotted drain grate is damaged the contractor shall replace it at their expence.

This work shall be measured lengthwise along the center of the drain. This work shall be paid for at the contract unit price per Foot for SLOTTED DRAINS TO BE ADJUSTED which shall include the grate extension.

FILE NAME =	USER NAME = duncanfa	DESIGNED -	REVISED -	<b>STATE OF ILLINOIS DEPARTMENT OF TRANSPORTATION</b>	<b>SLOTTED DRAINS TO BE ADJUSTED</b>	F.A.I. RTE.	SECTION	COUNTY	TOTAL SHEETS	SHEET NO.	
ca\piv_work\PWIDOT\DUNCANFA\dms33952\dms33952-shr-ts.dgn		DRAWN -	REVISED -			74	81-1-2, 1, 2-2/RS-1&M	ROCK ISLAND	246	120	
PLOT SCALE = 50,0000 ' / IN.		CHECKED -	REVISED -			CONTRACT NO. 64A97					
PLOT DATE = Fri Feb 06 10:55:00 2009		DATE -	REVISED -			FED. ROAD DIST. NO. ILLINOIS FED. AID PROJECT					
						SCALE:	SHEET NO.	OF	SHEETS	STA.	TO STA.

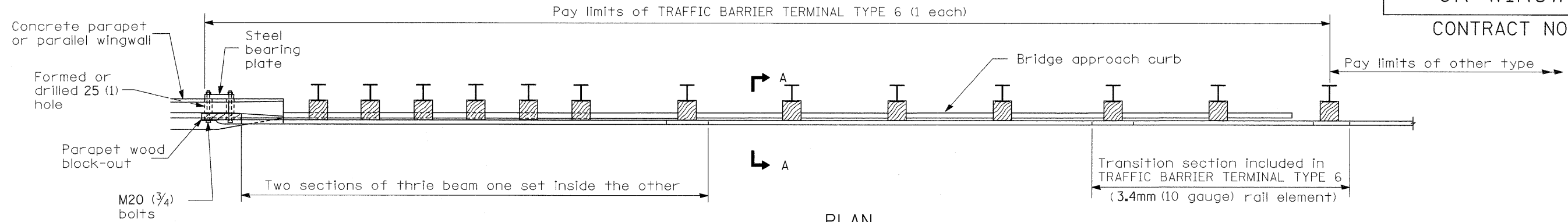

PLAN

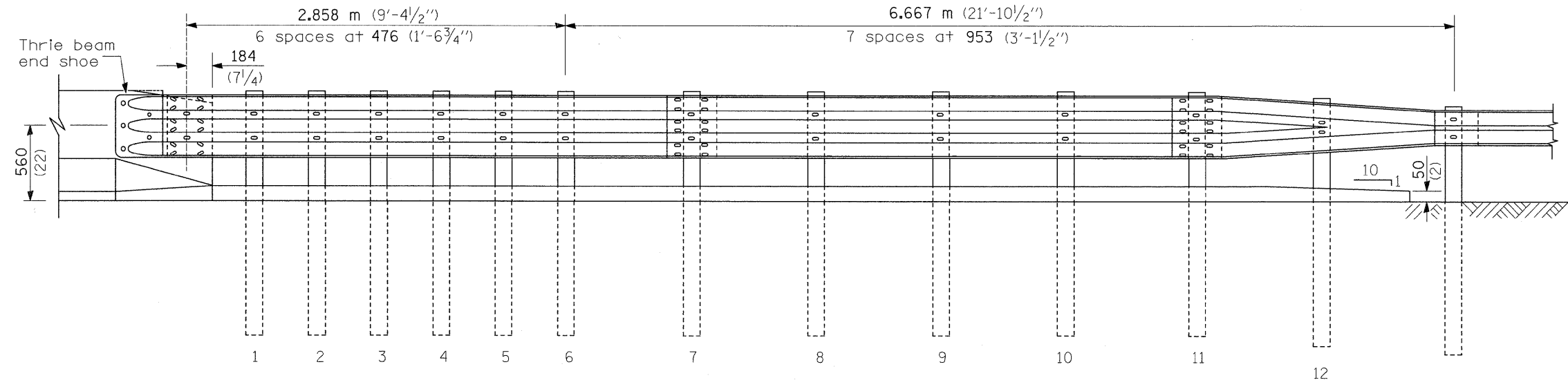

ELEVATION

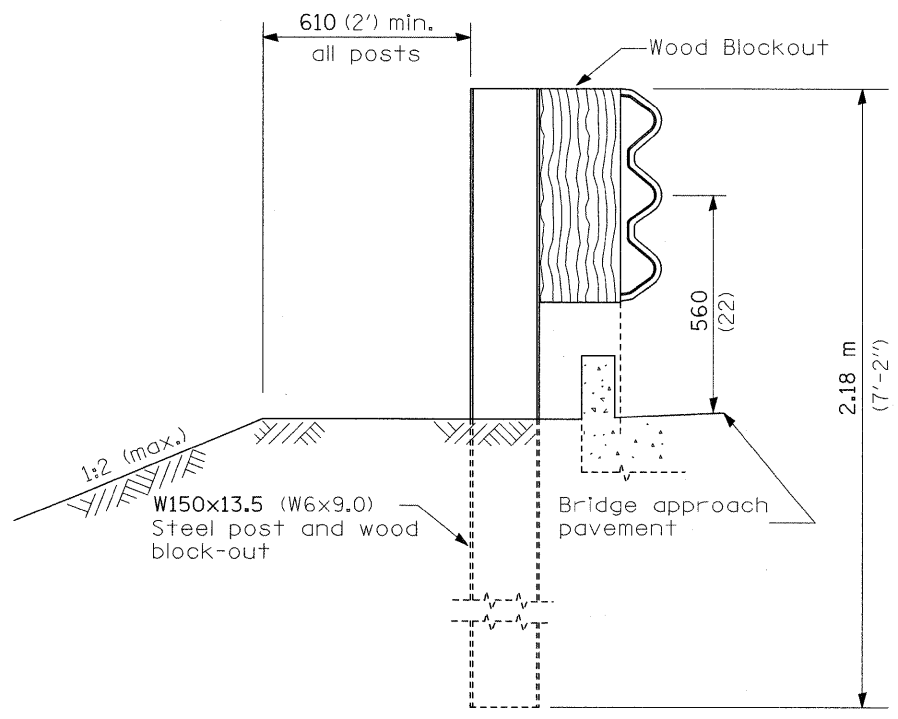

SECTION A-A

GENERAL NOTES

THIS HIGHWAY STANDARD (631031-05, REVISION 207) IS TO BE USED FOR "TRAFFIC BARRIER TERMINAL, TYPE 6 (SPECIAL)".

See District Standard 53.1 for details of guardrail not shown.

Thrie beam rail shall be bolted to block-out at all posts.

All slope ratios are expressed as units of vertical displacement to units of horizontal displacement (V:H).

All dimensions are in millimeters (inches) unless otherwise shown.

TRAFFIC BARRIER  
TERMINAL, TYPE 6  
(SPECIAL)



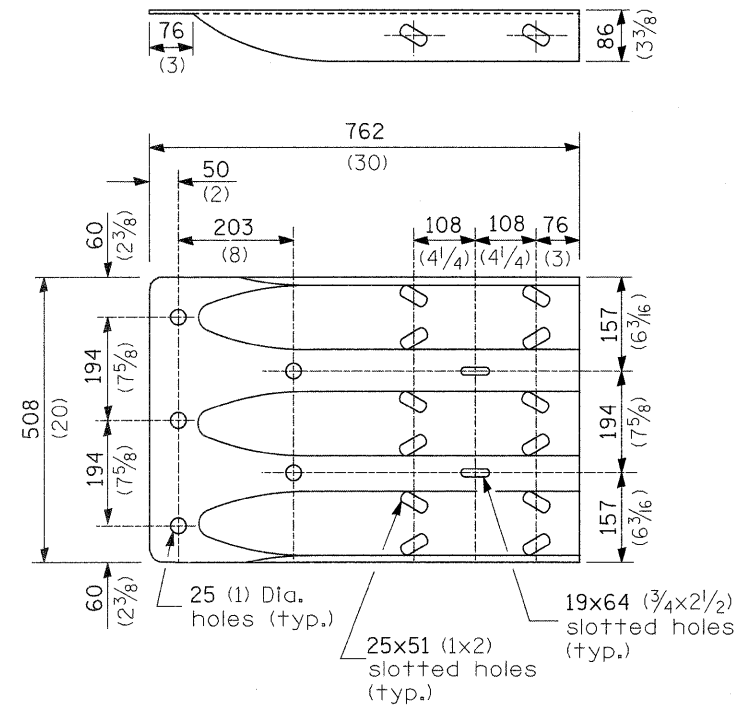

THRIE BEAM END SHOE DETAIL

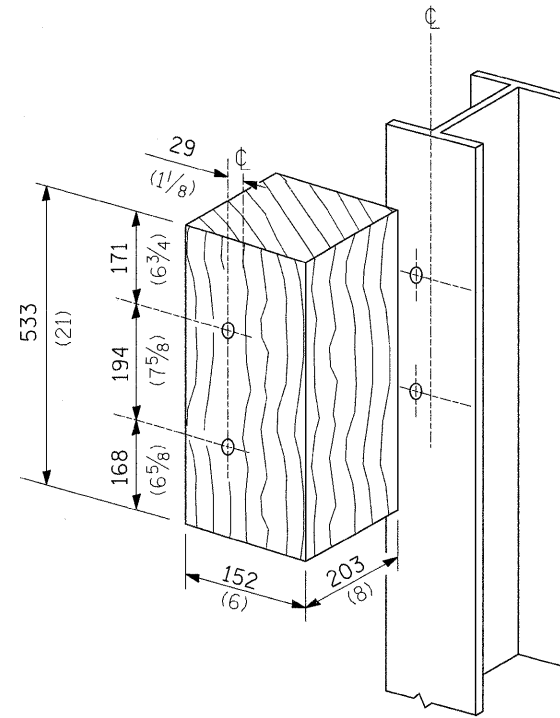

POSTS 1-11 WOOD BLOCKOUT DETAIL

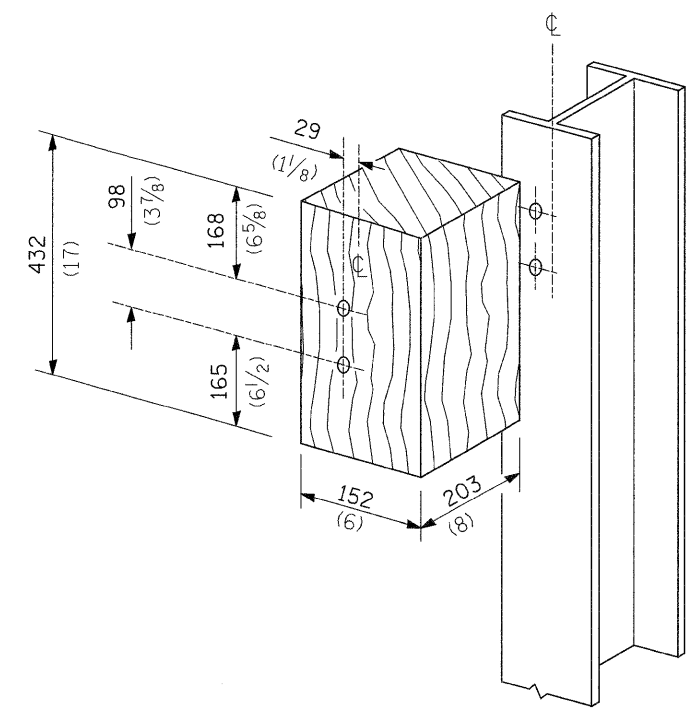

POST 12 WOOD BLOCKOUT DETAIL

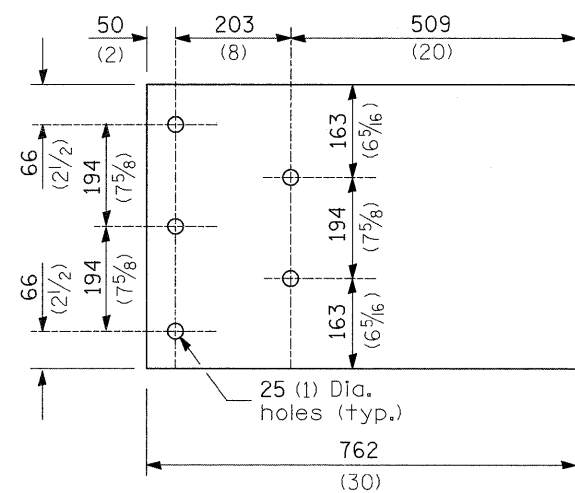

PARAPET WOOD BLOCK-OUT DETAIL

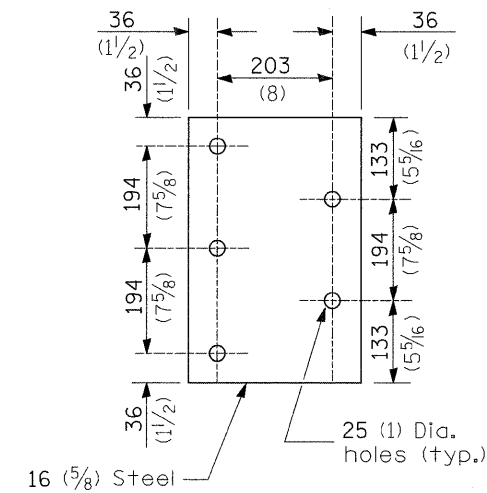
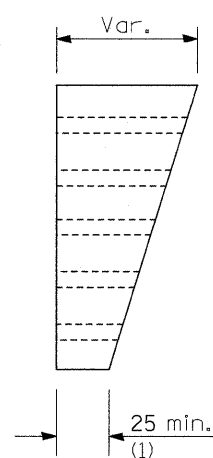

PARAPET STEEL BEARING PLATE DETAIL

(5 each individual 125x125x16 (5x5x5/8) steel plates with centered 25 (1) holes may be substituted for the plate shown.)

TRAFFIC BARRIER  
TERMINAL, TYPE 6  
(SPECIAL)

F.A.I. RTE.	SECTION	COUNTY	TOTAL SHEETS	SHEET NO.
505	81-(1-2,1,2-2)RS-1&M	ROCK ISLAND	246	124
FED. ROAD DIST. NO.	ILLINOIS	CONTRACT NO. 64A97		

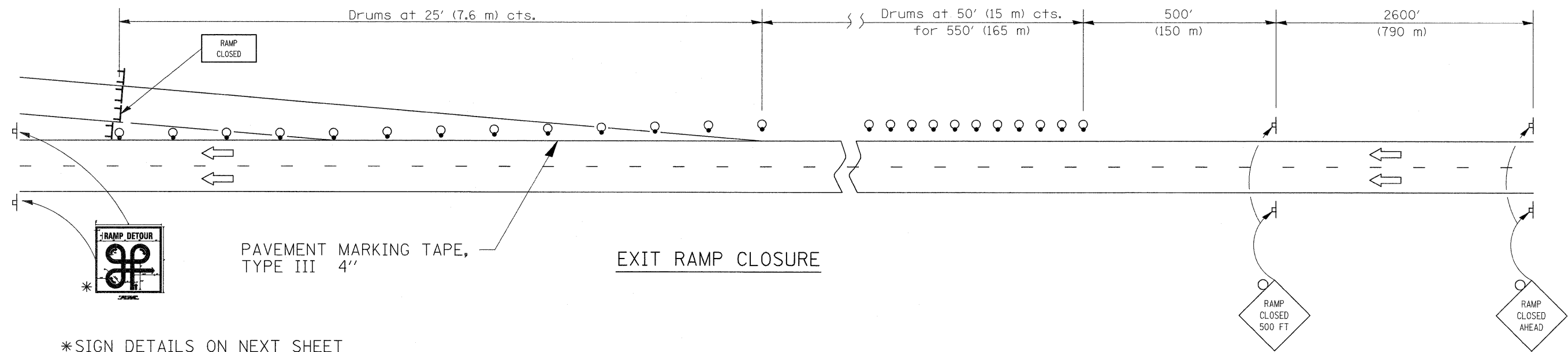

\*SIGN DETAILS ON NEXT SHEET

All dimensions are in inches (millimeters) unless otherwise shown.

RAMP CLOSURE  
FREEWAY/EXPRESSWAY

---



STANDARD 701451 SPL

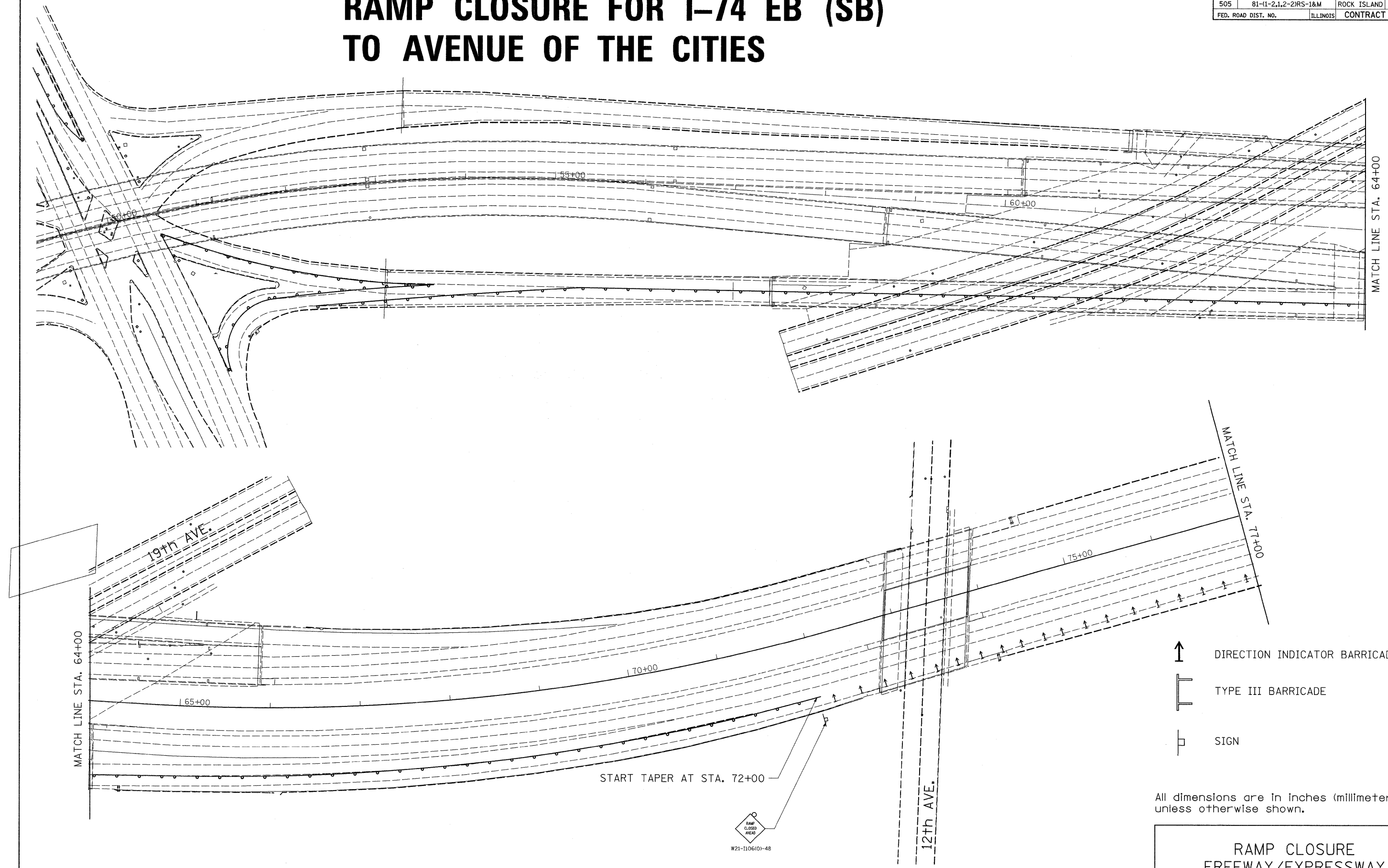

# RAMP CLOSURE FOR I-74 EB (SB) TO AVENUE OF THE CITIES

F.A.T. RTE.	SECTION	COUNTY	TOTAL SHEETS	SHEET NO.
505	81-(1-2,1,2-2)RS-1&M	ROCK ISLAND	246	125
FED. ROAD DIST. NO.	ILLINOIS	CONTRACT NO. 64A97		



-  DIRECTION INDICATOR BARRICADE
-  TYPE III BARRICADE
-  SIGN

All dimensions are in inches (millimeters) unless otherwise shown.

RAMP CLOSURE  
FREEWAY/EXPRESSWAY

---

STANDARD 701451 SPL

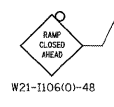

# RAMP CLOSURE FOR I-74 EB (SB) TO AVENUE OF THE CITIES

F.A.I. RTE.	SECTION	COUNTY	TOTAL SHEETS	SHEET NO.
505	81-1-2,1,2-2RS-1&M	ROCK ISLAND	246	126
FED. ROAD DIST. NO.	ILLINOIS	CONTRACT NO. 64A97		

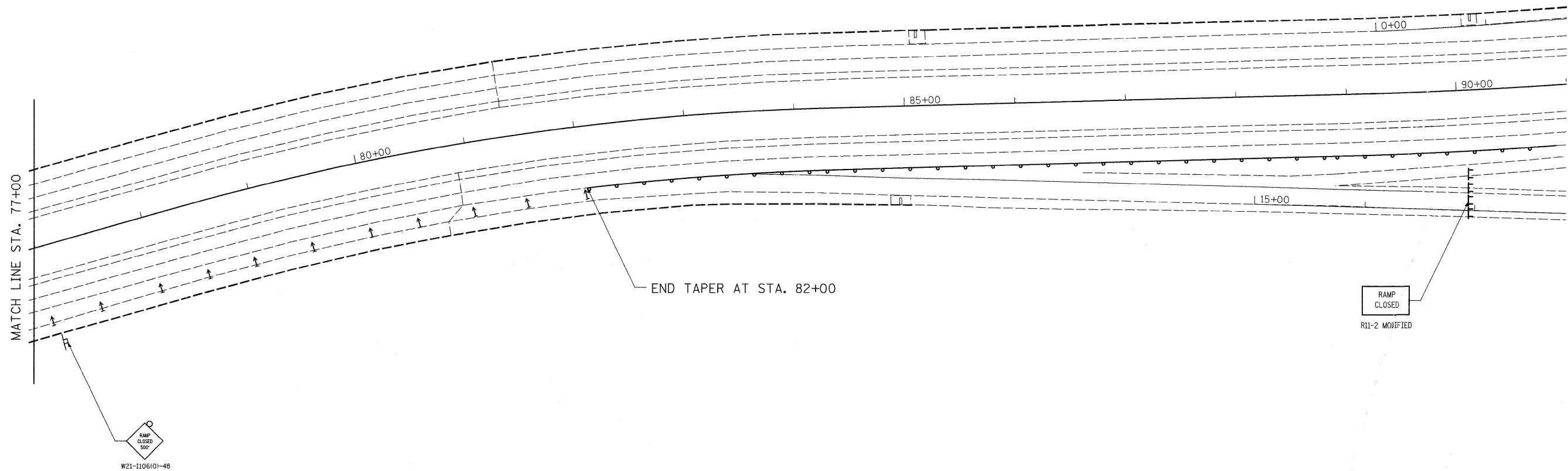

- ↑ DIRECTION INDICATOR BARRICADE
- ┌ TYPE III BARRICADE
- └ SIGN

All dimensions are in inches (millimeters) unless otherwise shown.

RAMP CLOSURE  
FREEWAY/EXPRESSWAY

---

STANDARD 701451 SPL

F.A.I. RTE.	SECTION	COUNTY	TOTAL SHEETS	SHEET NO.
505	81-(1-2,1,2-2)RS-1&M	ROCK ISLAND	246	127
FED. ROAD DIST. NO.	ILLINOIS	CONTRACT NO. 64A97		

# RAMP CLOSURE FOR I-74 WB (NB) TO IL 5 EB

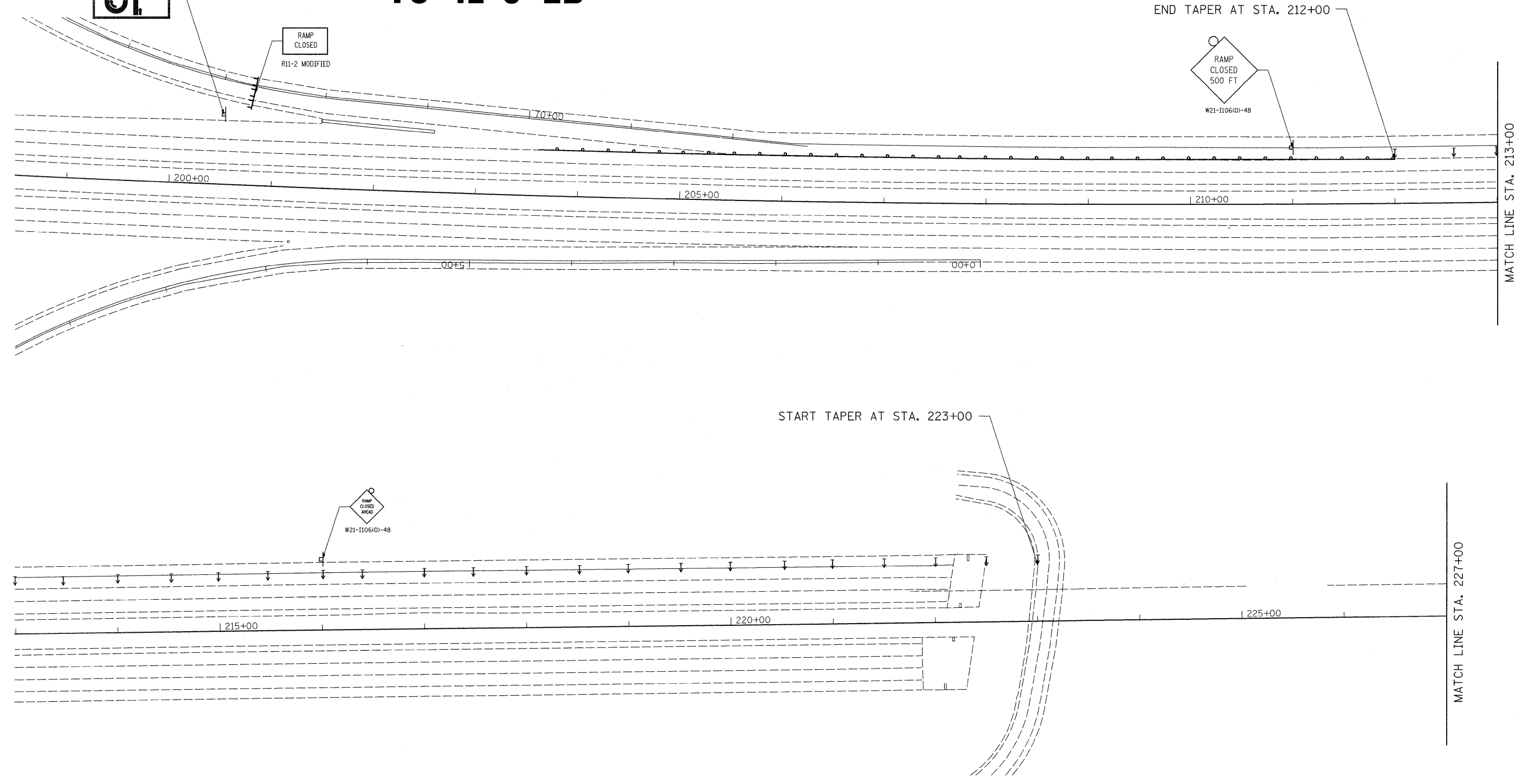
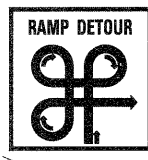

All dimensions are in inches (millimeters) unless otherwise shown.

RAMP CLOSURE  
FREEWAY/EXPRESSWAY

---

STANDARD 701451 SPL

# RAMP CLOSURE FOR I-74 WB (NB) TO IL 5 EB

F.A.I. RTE.	SECTION	COUNTY	TOTAL SHEETS	SHEET NO.
505	81-(1-2,1,2-2)RS-1&M	ROCK ISLAND	246	128
FED. ROAD DIST. NO.	ILLINOIS	CONTRACT NO. 64A97		

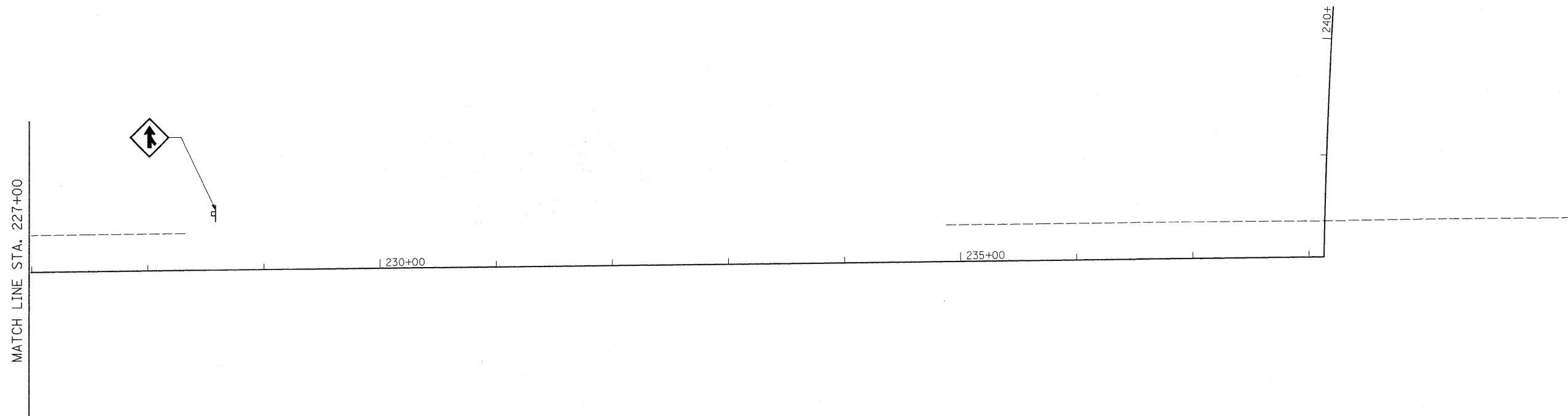

All dimensions are in inches (millimeters) unless otherwise shown.

RAMP CLOSURE  
FREEWAY/EXPRESSWAY

STANDARD 701451 SPL

# SUMMARY OF STRUCTURAL PLANS

CODE NUMBER	ITEM	UNIT	SN 081-0099	SN 081-0100	SN 081-0101	SN 081-0102	SN 081-0103	SN 081-0104	SN 081-0105	SN 081-0108	SN 081-0109	SN 081-0110	TOTALS
28100101	STONE RIPRAP, CLASS A1	SQ YD	---	---	---	---	---	---	---	29.9	---	---	30
40603565	POLYMERIZED HOT-MIX ASPHALT SURFACE COURSE, MIX "E", N70	TON	252.00	268.00	102.00	74.00	122.00	96.00	348.00	---	862.00	66.60	2,191
50102400	CONCRETE REMOVAL	CU YD	37.5	37.5	16.2	12.4	29.9	21.8	27.3	17.6	16.6	15.8	232.6
50104650	SLOPE WALL REMOVAL	SQ YD	---	---	---	---	---	---	554	---	---	---	554
50157300	PROTECTIVE SHIELD	SQ YD	1,011	820	354	252	305	232	1,179	---	354	330	4,837
50300255	CONCRETE SUPERSTRUCTURE	CU YD	37.5	37.5	16.2	12.4	29.9	21.8	27.3	17.6	16.6	15.8	232.6
50800205	REINFORCEMENT BARS, EPOXY COATED	POUND	4530	4580	1,850	1,390	2,720	2,100	3,770	2,170	2,230	2,080	27,420
50800515	BAR SPLICERS	EACH	70	70	22	22	22	22	44	22	22	22	338
51100100	SLOPE WALL 4 INCH	SQ YD	---	---	---	---	---	---	554	---	---	---	554
52000110	PREFORMED JOINT STRIP SEAL	FOOT	170	170	117	86	184	139	240	112	114	107	1,439
58100200	WATERPROOFING MEMBRANE SYSTEM	SQ YD	2,245	2,389	570.7	414.3	1,170	924.0	2,340.0	---	799.2	746.2	11,598
59300100	CONTROLLED LOW-STRENGTH MATERIAL	CU YD	---	---	---	---	---	---	---	1.0	---	---	1.0
60100945	PIPE DRAINS 12"	FOOT	---	---	---	---	---	---	---	---	15	---	15
63300405	REMOVAL AND REINSTALLATION OF EXISTING TRAFFIC BARRIER TERMINAL, TYPE I	EACH	3	3	---	---	---	---	---	---	---	---	6
X0301424	SILICONE JOINT SEALER	FOOT	---	---	---	---	---	---	234	14	---	---	248
X0321316	ACCESS DOOR	EACH	---	---	---	---	---	---	---	2	---	---	2
X0324865	DIAMOND GRINDING (BRIDGE SECTION)	SQ YD	2,245	2,389	570.7	414.3	1,170	924	2,340	---	799.2	746.2	11,598
X0325303	STRUCTURAL REPAIR OF CONCRETE (DEPTH GREATER THAN 5 INCHES)	SQ FT	---	---	---	---	---	---	162	---	18	27	207
Z0006200	BRIDGE DECK SCARIFICATION	SQ YD	2,323	2,466	564.5	409.8	1,160	917	2,330	---	793.1	740.5	11,704
Z0016001	DECK SLAB REPAIR (FULL DEPTH, TYPE I)	SQ YD	25	25	32	22.7	162.5	25	---	---	47.5	70	410
Z0016002	DECK SLAB REPAIR (FULL DEPTH, TYPE II)	SQ YD	400	500	32	22.7	162.5	25	3	---	47.5	70	1,263
Z0016200	DECK SLAB REPAIR (PARTIAL)	SQ YD	450	450	64	50.5	120	120	27	---	10	20	1,312
Z0032470	JOINT SEALER	FOOT	---	---	---	---	---	---	---	62	---	---	62



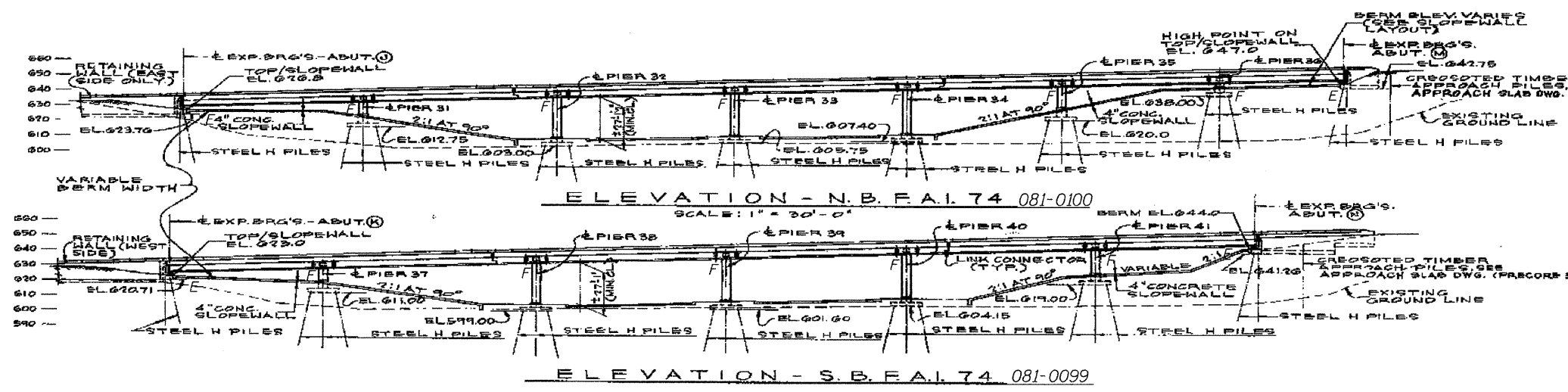

**General Notes**

- Reinforcement bars shall conform to the requirements of ASTM A 706 Gr 60. See Special Provisions.
- Reinforcement bars designated (E) shall be epoxy coated.
- Prior to pouring the new concrete deck, all heavy or loose rust, loose mill scale, and other loose or potentially detrimental foreign material shall be removed from the surfaces in contact with concrete. Tightly adhered paint may remain unless otherwise noted. Removal shall be accomplished by methods that will not damage the steel and the cost will be included in the pay item covering removal of the existing concrete.
- Plan dimensions and details relative to existing plans are subject to nominal construction variations. The Contractor shall field verify existing dimensions and details affecting new construction and make necessary approved adjustments prior to construction or ordering of materials. Such variations shall not be cause for additional compensation for a change in the scope of the work; however, the Contractor will be paid for the quantity actually furnished at the unit price bid for the work.
- The existing structural steel coating contains lead. The Contractor shall take appropriate precautions to deal with the presence of lead on this project.
- Existing reinforcement bars extending into the removal area shall be cleaned, straightened and incorporated into the new construction. Any reinforcement bars that are damaged during concrete removal shall be replaced with an approved bar splicer or anchorage system. Cost included with Concrete Removal.
- Joint openings shall be adjusted according to Article 520.04 of the Standard Specifications when the deck is poured at an ambient temperature other than 50° F.

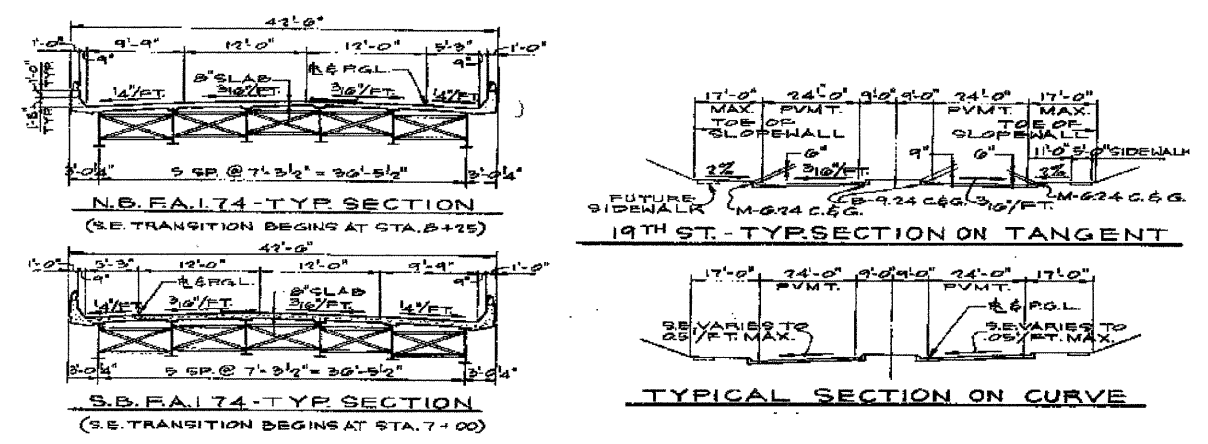
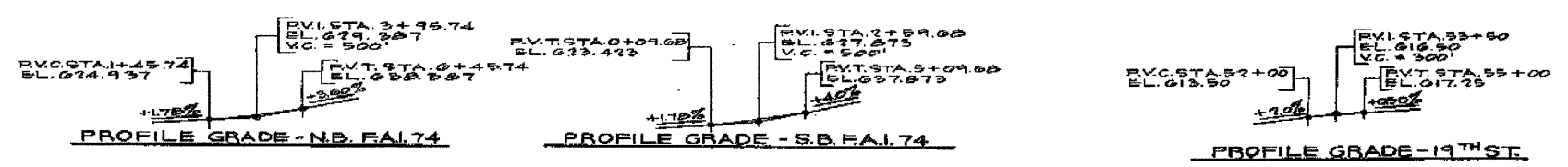

**TOTAL BILL OF MATERIAL**

ITEM	UNIT	TOTAL	081-0099	081-0100
CONCRETE SUPERSTRUCTURE	CU YD	75	37.5	37.5
CONCRETE REMOVAL	CU YD	75	37.5	37.5
REINFORCEMENT BARS, EPOXY COATED	POUND	9110	4530	4580
PREFORMED JOINT STRIP SEAL	FOOT	340	170	170
BAR SPLICERS	EACH	140	70	70
REMOVAL AND REINSTALLATION OF EXISTING TRAFFIC BARRIER TERMINAL, TYPE 1	EACH	6	3	3
WATERPROOFING MEMBRANE SYSTEM	SQ YD	4634	2245	2389
BRIDGE DECK SCARIFICATION	SQ YD	4789	2323	2466
DECK SLAB REPAIR (FULL DEPTH, TYPE I)	SQ YD	50	25	25
DECK SLAB REPAIR (FULL DEPTH, TYPE II)	SQ YD	900	400	500
DECK SLAB REPAIR (PARTIAL)	SQ YD	900	450	450
POLYMERIZED HOT-MIX ASPHALT SURFACE COURSE, MIX "E", N70	TON	520	252	268
PROTECTIVE SHIELD	SQ YD	1831	1011	820
DIAMOND GRINDING (BRIDGE SECTION)	SQ YD	4634	2245	2389

**GENERAL PLAN & ELEVATION**  
**I-74 OVER 19th STREET**  
**FAI 74 (I-74)**  
**SECTION 81-(1-2,1,2-2)RS-1 & M**  
**ROCK ISLAND COUNTY**  
**STRUCTURE NUMBER 081-0099 (SB) &**  
**081-0100 (NB)**

Sheet 2 of 18

FILE NAME = #FILE#	USER NAME = #USER#	DESIGNED - -	REVISED - -	<b>STATE OF ILLINOIS DEPARTMENT OF TRANSPORTATION</b>	<b>GENERAL PLAN &amp; ELEVATION</b>	F.A.I. RTE. 74	SECTION 81-(1-2,1,2-2)RS-1 & M	COUNTY ROCK ISLAND	TOTAL SHEETS 146	SHEET NO. 131	
PLOT SCALE = #SCALE#	CHECKED - -	REVISED - -	SCALE: _____			SHEET NO. ____ OF ____ SHEETS	STA. _____ TO STA. _____	FED. ROAD DIST. NO. _____ ILLINOIS FED. AID PROJECT			
PLOT DATE = #DATE#	DATE - -	REVISED - -									
CONTRACT NO. 64A97											

# STAGING PLAN

STAGE I CONSTRUCTION  
Structure 081-0099 Southbound

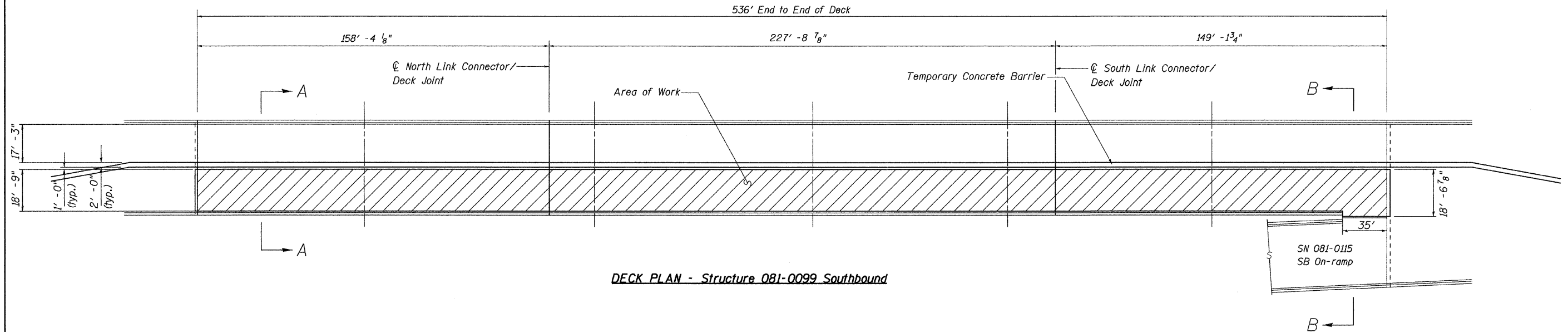

DECK PLAN - Structure 081-0099 Southbound

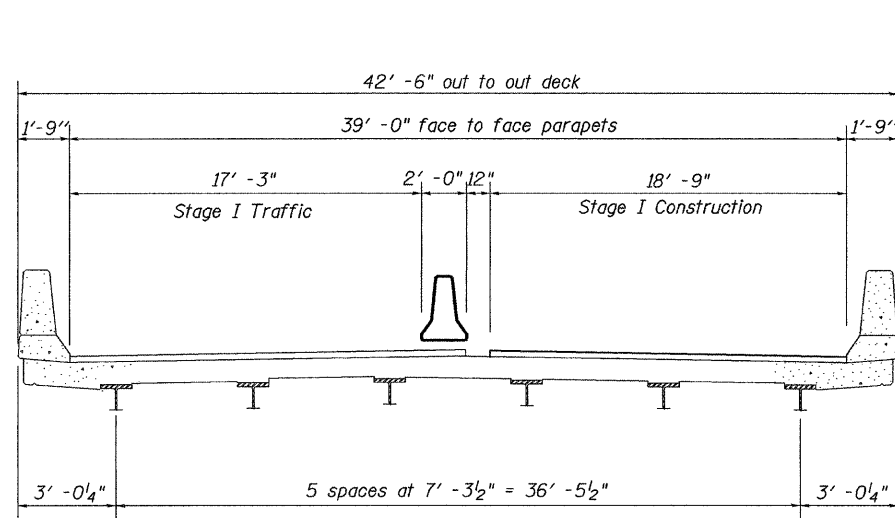

CROSS SECTION A-A Structure 081-0099 Southbound  
(Normal Section - Looking South)

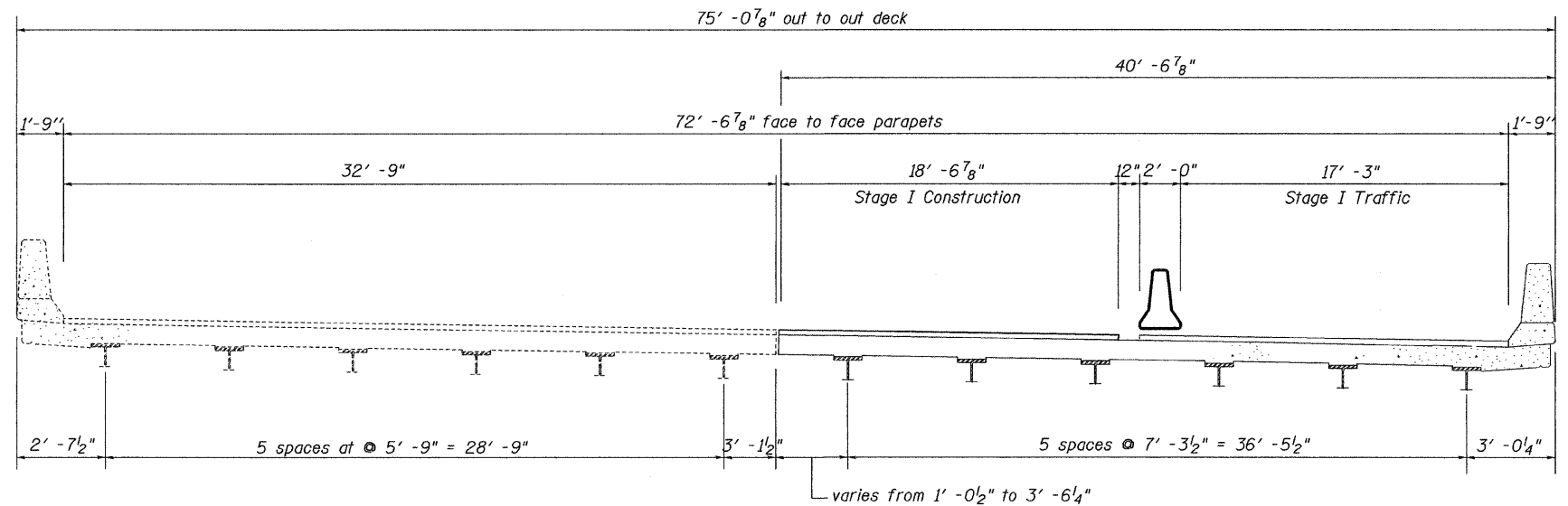

CROSS SECTION B-B Structure 081-0099 Southbound  
(At South Abutment - Looking North)

## STAGE I CONSTRUCTION

- Install Temporary Concrete Barrier.
- Move Traffic to Stage I Traffic.
- Sawcut concrete wearing surface.
- Replace bridge joints & repair deck.
- Install new wearing surface & waterproofing membrane.

## STAGE I CONSTRUCTION

STAGING PLAN  
I-74 OVER 19th STREET  
FAI 74 (I-74)  
SECTION 81-(1-2,1,2-2)RS-1 & M  
ROCK ISLAND COUNTY  
STRUCTURE NUMBER 081-0099 (SB)

Sheet 3 of 18

FILE NAME =	USER NAME = #USER#	DESIGNED - -	REVISED - -	<b>STATE OF ILLINOIS DEPARTMENT OF TRANSPORTATION</b>	<b>STAGING PLAN</b>	F.A.I. RTE.	SECTION	COUNTY	TOTAL SHEETS	SHEET NO.	
#FILEL#		DRAWN - -	REVISED - -			74	81-(1-2,1,2-2)RS-1 & M	ROCK ISLAND	246	132	
		CHECKED - -	REVISED - -			CONTRACT NO. 64A97		FED. ROAD DIST. NO. - ILLINOIS FED. AID PROJECT			
		DATE - -	REVISED - -			SCALE: _____ SHEET NO. ___ OF ___ SHEETS STA. _____ TO STA. _____					





# STAGING PLAN

STAGE II CONSTRUCTION  
Structure 081-0099 Southbound

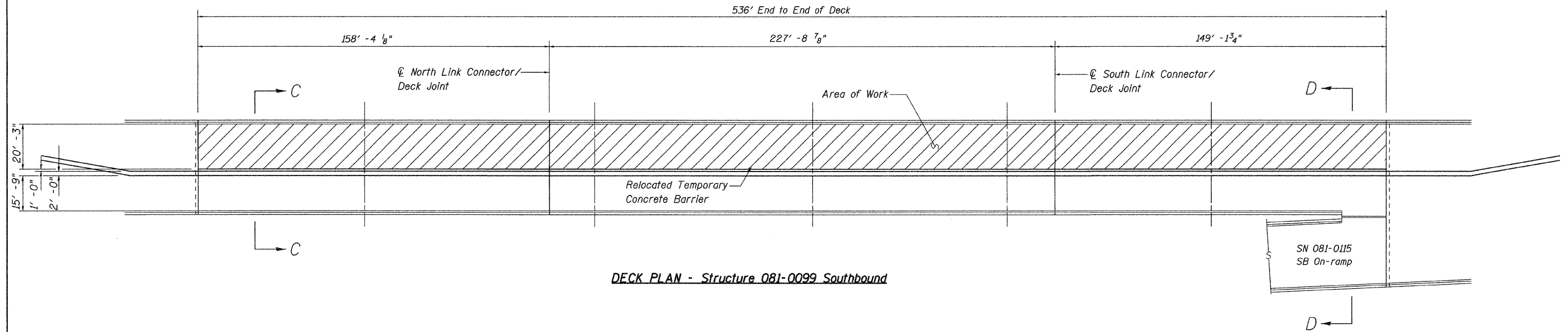

DECK PLAN - Structure 081-0099 Southbound

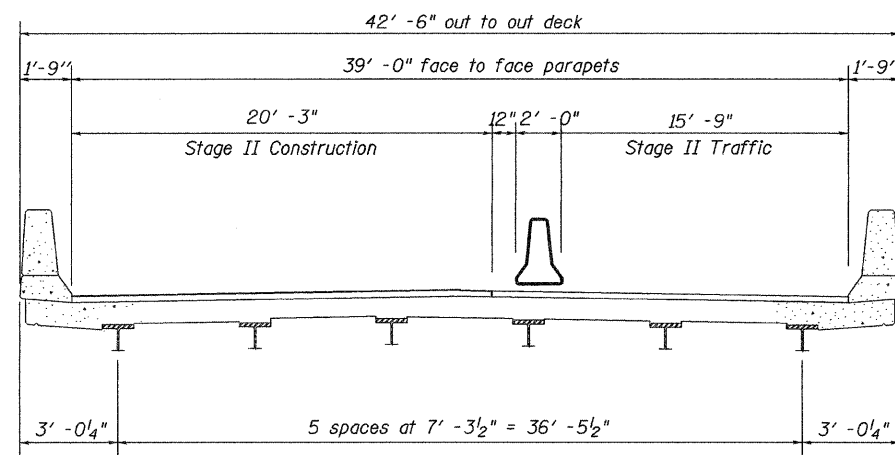

CROSS SECTION C-C Structure 081-0099 Southbound  
(Normal Section - Looking South)

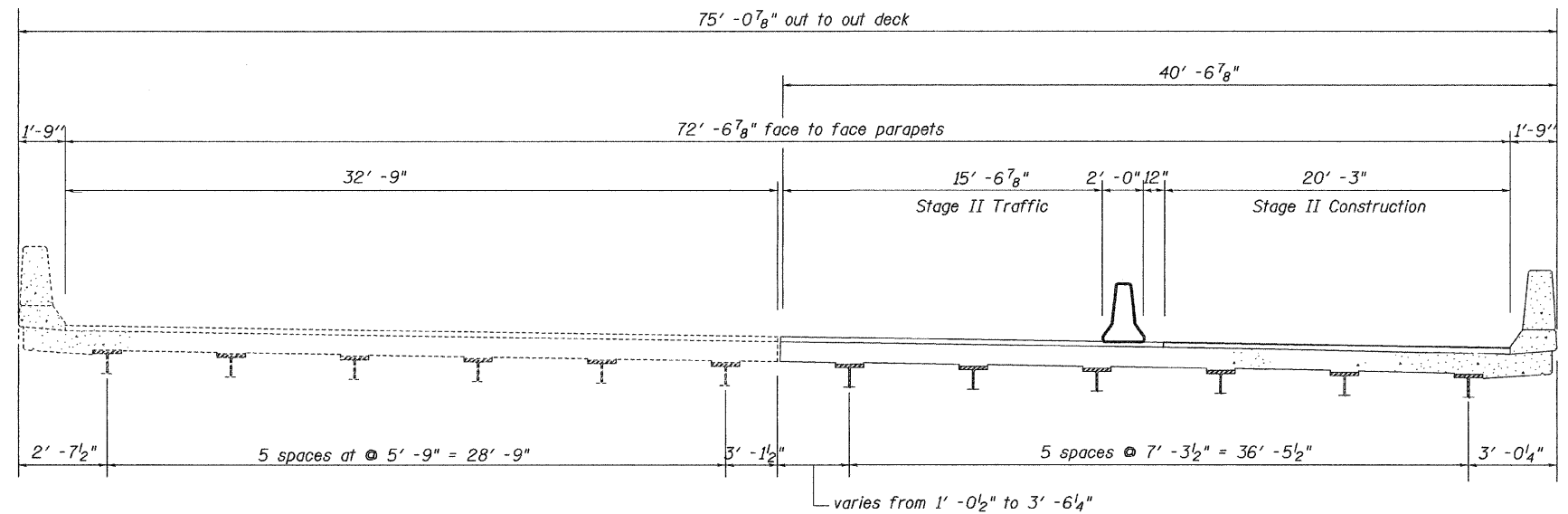

CROSS SECTION D-D Structure 081-0099 Southbound  
(At South Abutment - Looking North)

## STAGE II CONSTRUCTION

- Relocate Temporary Concrete Barrier.
- Move Traffic to Stage II Traffic.
- Remove concrete wearing surface.
- Replace bridge joints & repair deck.
- Install new wearing surface & waterproofing membrane.
- Remove temporary concrete barrier.

Structure 081-0115  
(Not part of this contract)

STAGING PLAN  
I-74 OVER 19th STREET  
FAI 74 (I-74)  
SECTION 81-(1-2,1,2-2)RS-1 & M  
ROCK ISLAND COUNTY  
STRUCTURE NUMBER 081-0099 (SB)

Sheet 4 of 18

FILE NAME = #FILE#	USER NAME = #USER#	DESIGNED - -	REVISED - -	<b>STATE OF ILLINOIS DEPARTMENT OF TRANSPORTATION</b>	<b>STAGING PLAN</b>	F.A.I. RTE. 74	SECTION 81-(1-2,1,2-2)RS-1 & M	COUNTY ROCK ISLAND	TOTAL SHEETS 246	SHEET NO. 131	
	PLOT SCALE = #SCALE#	DRAWN - -	REVISED - -			SCALE: _____	SHEET NO. ____ OF ____ SHEETS	CONTRACT NO. 64A97		FED. ROAD DIST. NO. - [ILLINOIS] FED. AID PROJECT	
	PLOT DATE = #DATE#	CHECKED - -	REVISED - -			STA. _____	TO STA. _____				
		DATE - -	REVISED - -								

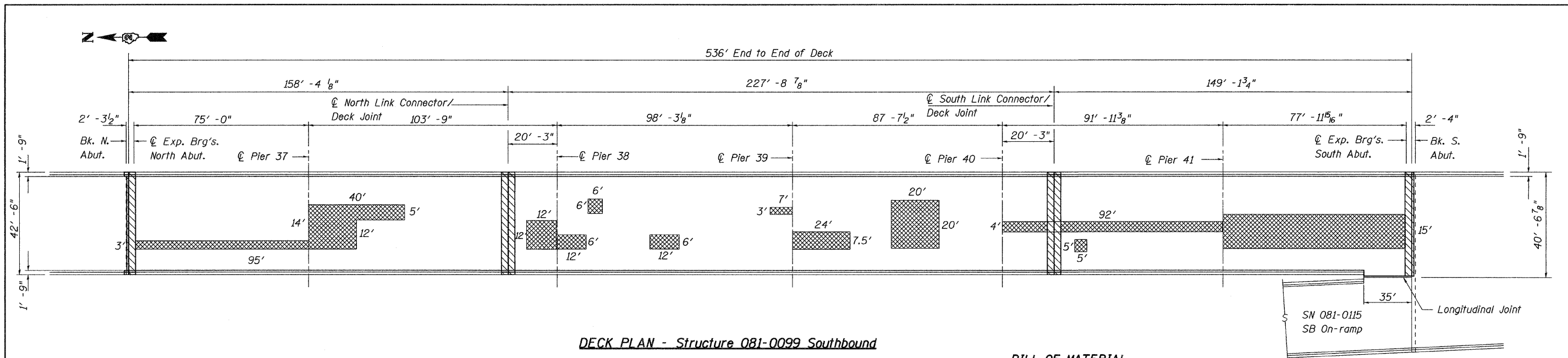

DECK PLAN - Structure 081-0099 Southbound

Legend

- Potential Full Depth Deck Repair
- Concrete Removal

Date of Survey: 05/02/2008

BILL OF MATERIAL

ITEM	UNIT	TOTAL
Polymerized HMA Surface Course Mix "E", N70	Ton	252
Waterproofing Membrane System	Sq Yd	2245
Bridge Deck Scarification	Sq Yd	2323
Protective Shield	Sq Yd	1011

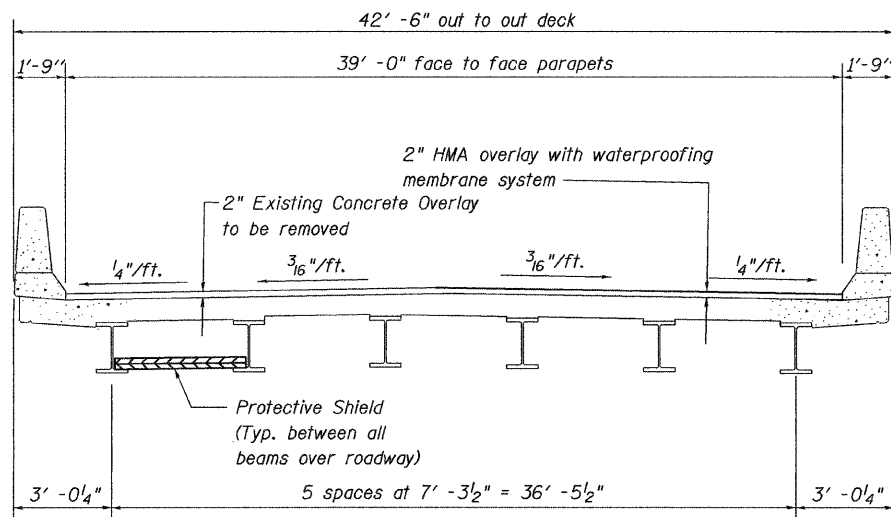

CROSS SECTION - Structure 081-0099 Southbound  
(Normal Section - Looking South)

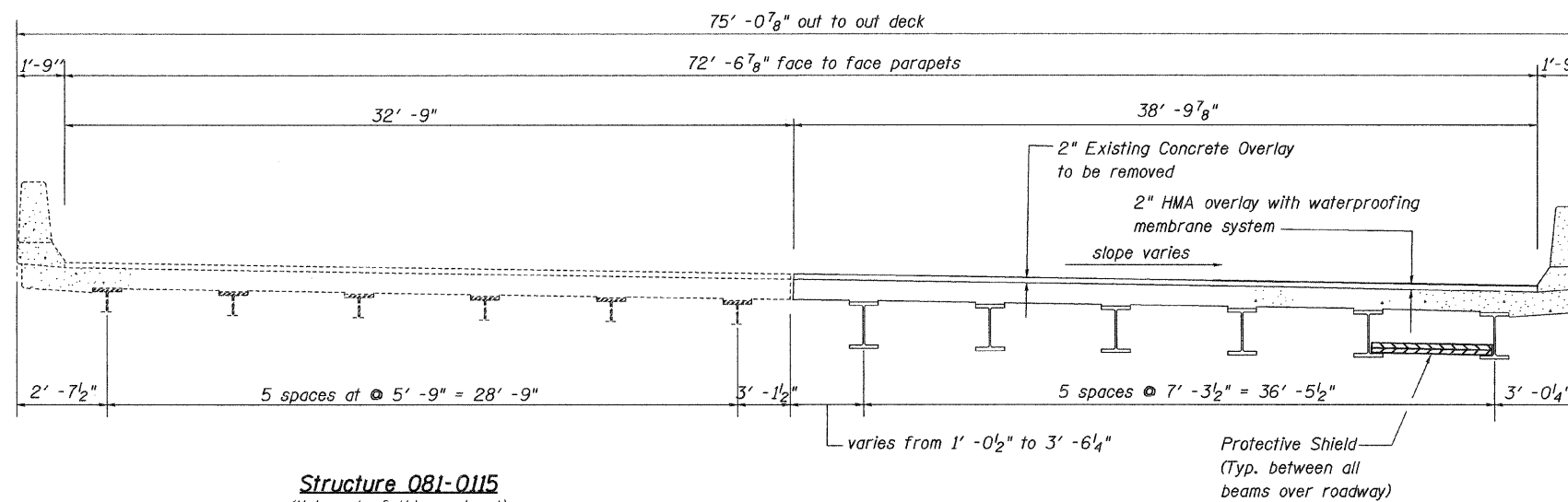

CROSS SECTION - Structure 081-0099 Southbound  
(At South Abutment - Looking North)

DECK PLAN & CROSS-SECTION  
I-74 OVER 19th STREET  
FAI 74 (I-74)  
SECTION 81-(1-2,1,2-2)RS-1 & M  
ROCK ISLAND COUNTY  
STRUCTURE NUMBER 081-0099 (SB)

Sheet 5 of 18

FILE NAME =	USER NAME = #USER#	DESIGNED - -	REVISED - -	<b>STATE OF ILLINOIS DEPARTMENT OF TRANSPORTATION</b>	<b>Deck Plan &amp; Cross Sections</b>	F.A.I. RTE.	SECTION	COUNTY	TOTAL SHEETS	SHEET NO.	
#FILEL#		DRAWN - -	REVISED - -			74	81-(1-2,1,2-2)RS-1 & M	ROCK ISLAND	246	134	
	PLOT SCALE = #SCALE#	CHECKED - -	REVISED - -			CONTRACT NO. 64A97		FED. ROAD DIST. NO. - ILLINOIS FED. AID PROJECT			
	PLOT DATE = #DATE#	DATE - -	REVISED - -			SCALE: _____ SHEET NO. ___ OF ___ SHEETS STA. _____ TO STA. _____					

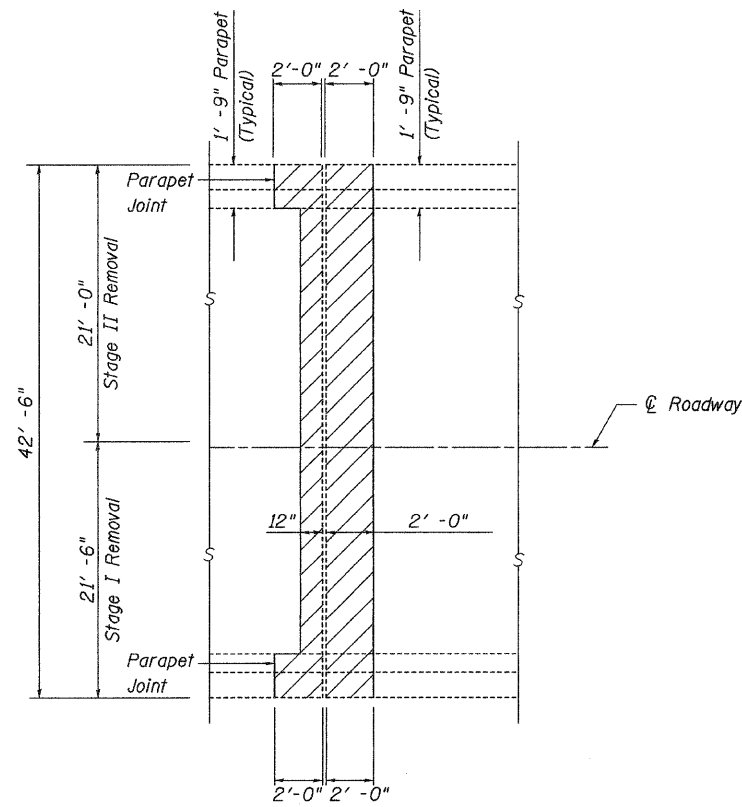

EXISTING PARTIAL PLAN  
(North Abutment)

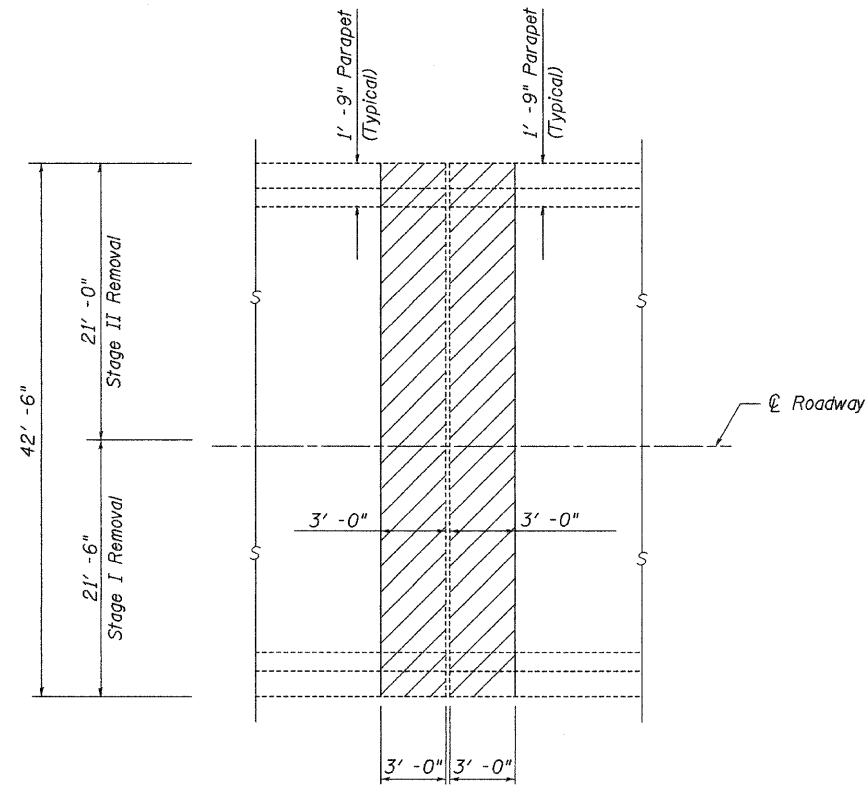

EXISTING PARTIAL PLAN  
(North Link Connection)

See sheet 9 of 18  
for bar details.

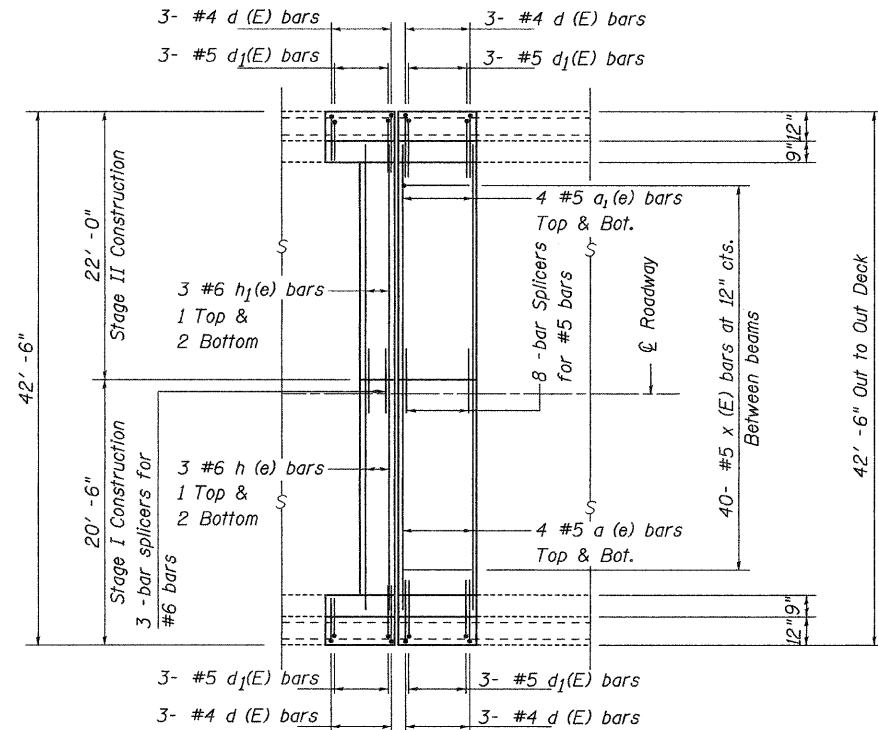

PROPOSED PARTIAL PLAN  
(North Abutment)

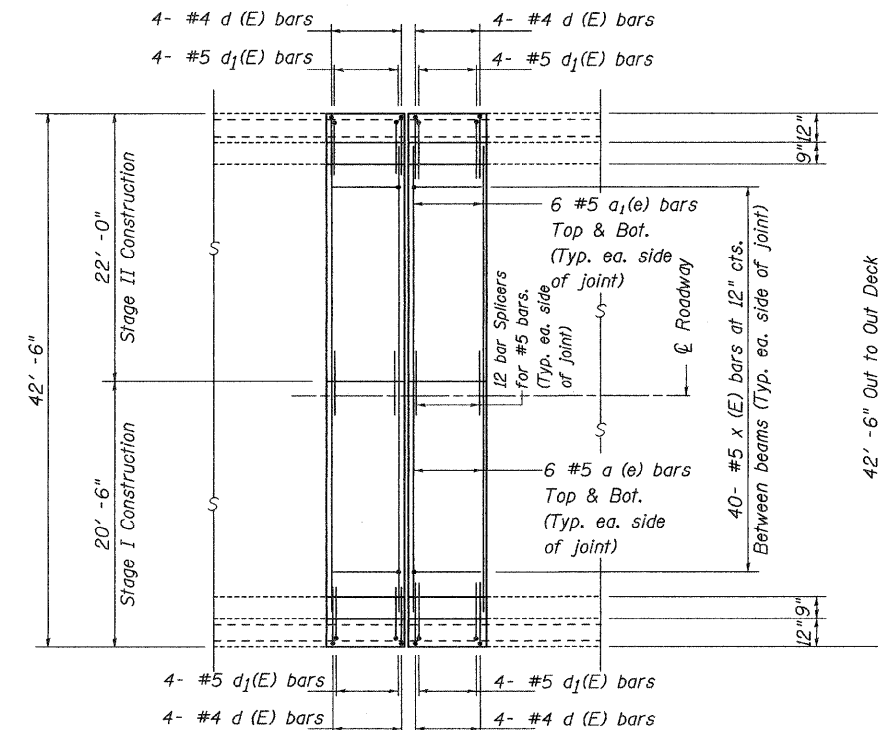

PROPOSED PARTIAL PLAN  
(North Link Connection)

JOINT DETAILS  
I-74 OVER 19th STREET  
FAI 74 (I-74)  
SECTION 81-(1-2,1,2-2)RS-1 & M  
ROCK ISLAND COUNTY  
STRUCTURE NUMBER 081-0099 (SB)

Sheet 6 of 18

FILE NAME =	USER NAME = #USER#	DESIGNED -	REVISED -
#FILEL#		DRAWN -	REVISED -
		CHECKED -	REVISED -
		DATE -	REVISED -

STATE OF ILLINOIS  
DEPARTMENT OF TRANSPORTATION

JOINT DETAILS

SCALE: \_\_\_\_\_ SHEET NO. \_\_\_ OF \_\_\_ SHEETS STA. \_\_\_\_\_ TO STA. \_\_\_\_\_

F.A.I. RTE.	SECTION	COUNTY	TOTAL SHEETS	SHEET NO.
74	81-(1-2,1,2-2)RS-1 & M	ROCK ISLAND	246	135
FED. ROAD DIST. NO. - ILLINOIS FED. AID PROJECT			CONTRACT NO. 64A97	

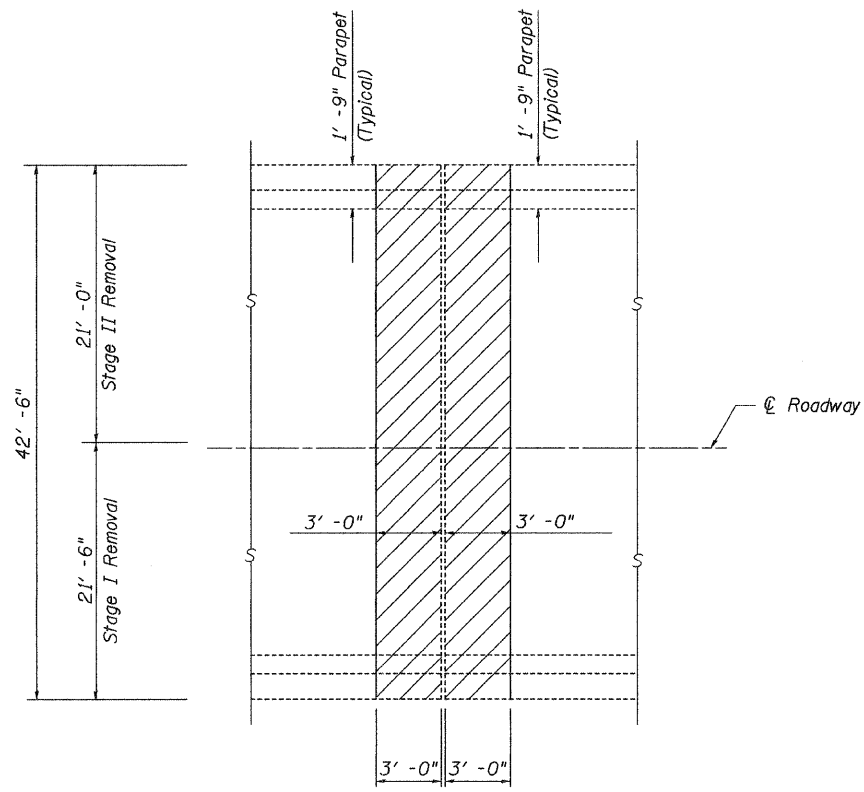

**EXISTING PARTIAL PLAN**  
(South Link Connection)

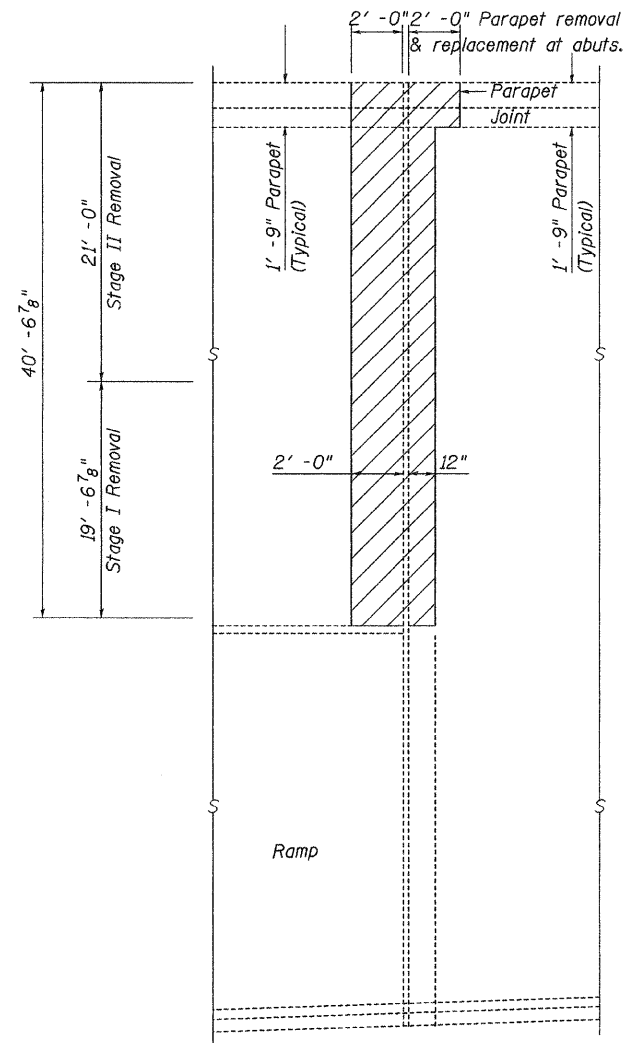

**EXISTING PARTIAL PLAN**  
(South Abutment)

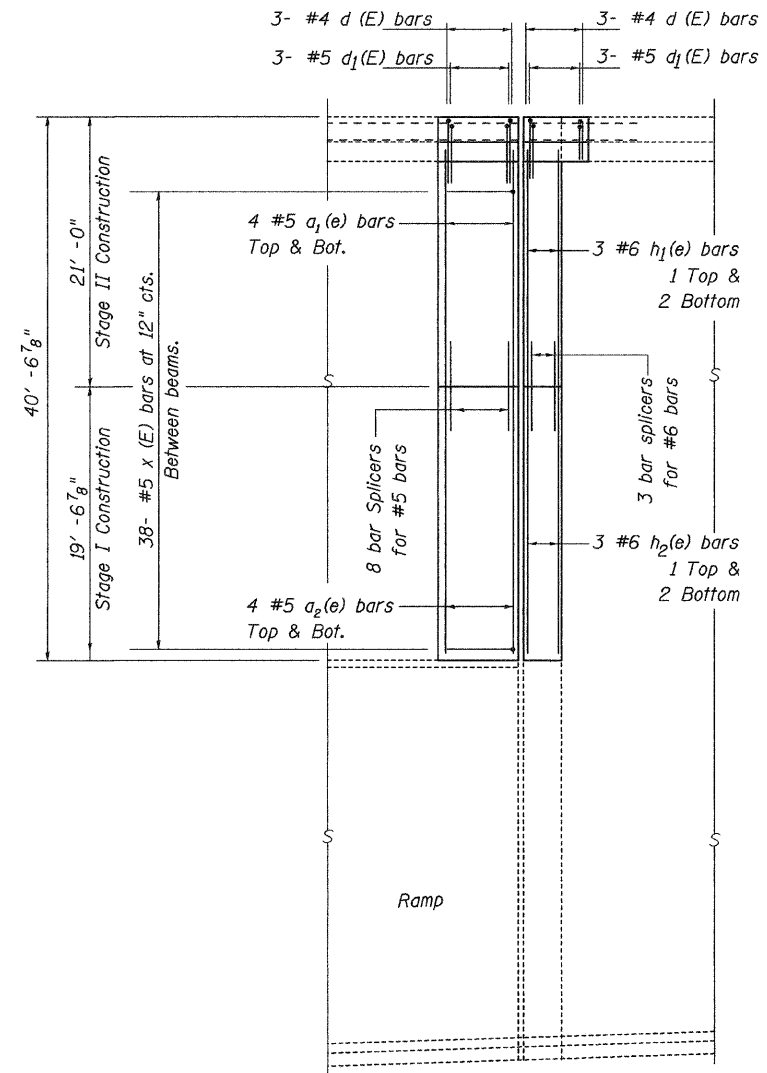

**PROPOSED PARTIAL PLAN**  
(South Abutment)

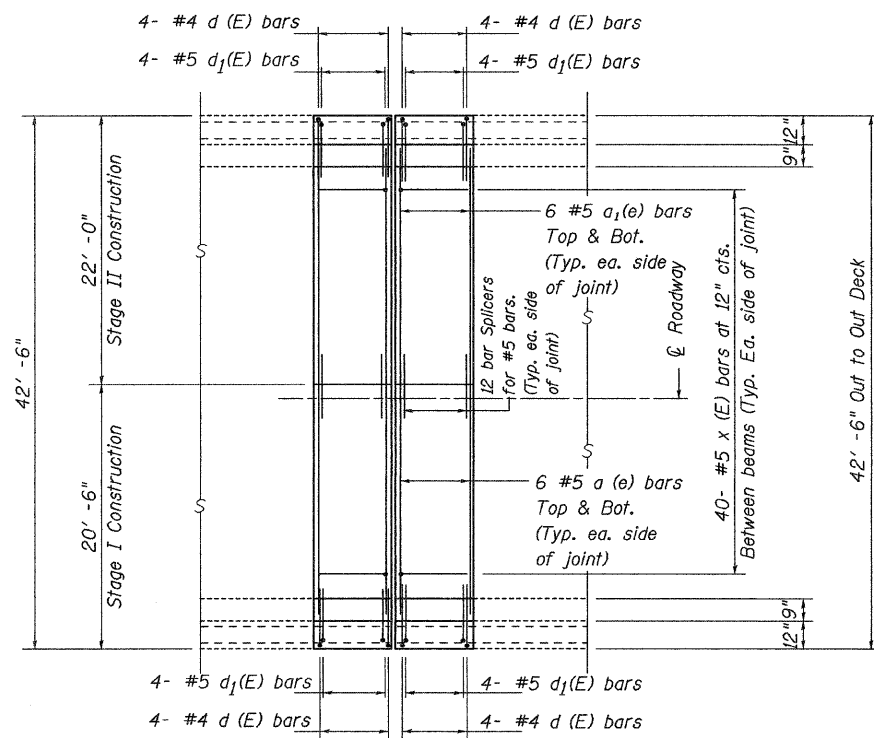

**PROPOSED PARTIAL PLAN**  
(South Link Connection)

See sheet 9 of 18  
for bar details.

**JOINT DETAILS**  
**I-74 OVER 19th STREET**  
**FAI 74 (I-74)**  
**SECTION 81-(1-2,1,2-2)RS-1 & M**  
**ROCK ISLAND COUNTY**  
**STRUCTURE NUMBER 081-0099 (SB)**

Sheet 7 of 18

FILE NAME =	USER NAME = #USER#	DESIGNED -	REVISED -	<b>STATE OF ILLINOIS DEPARTMENT OF TRANSPORTATION</b>	<b>JOINT DETAILS</b>	F.A.I. RTE.	SECTION	COUNTY	TOTAL SHEETS	SHEET NO.	
#FILEL#		DRAWN -	REVISED -			74	81-(1-2,1,2-2)RS-1 & M	ROCK ISLAND	246	126	
PLOT SCALE = #SCALE#		CHECKED -	REVISED -			CONTRACT NO. 64A97		ILLINOIS FED. AID PROJECT			
PLOT DATE = #DATE#		DATE -	REVISED -			SCALE: _____	SHEET NO. _____ OF _____ SHEETS	STA. _____ TO STA. _____			

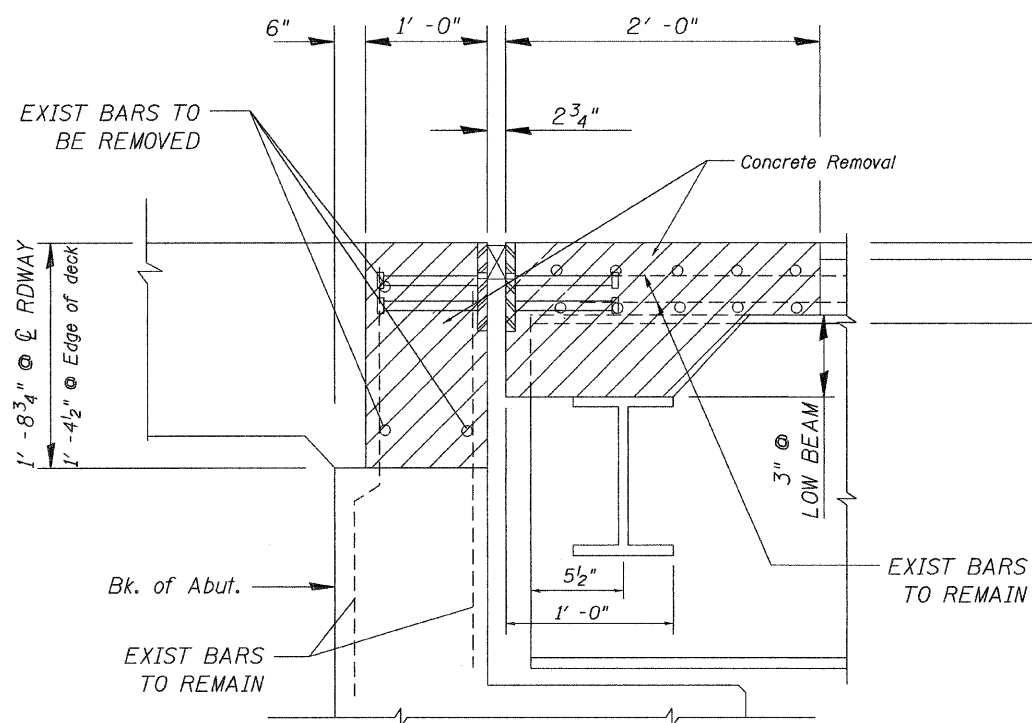

EXIST SECTION THRU ABUTMENTS

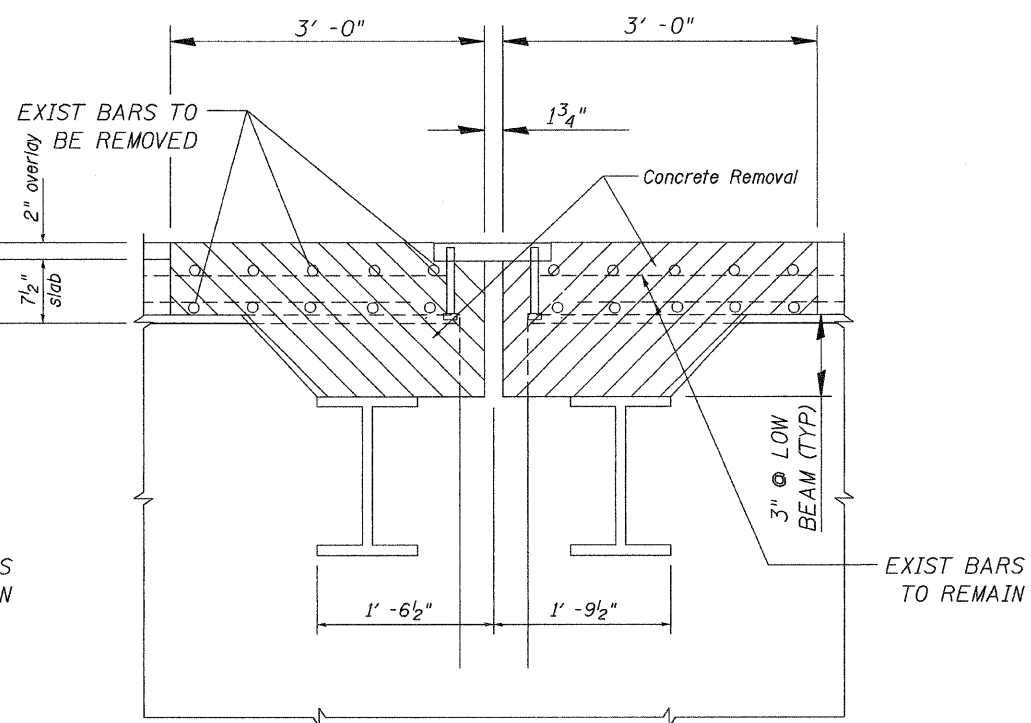

EXIST SECTION THRU DECK JOINTS  
(Looking East)

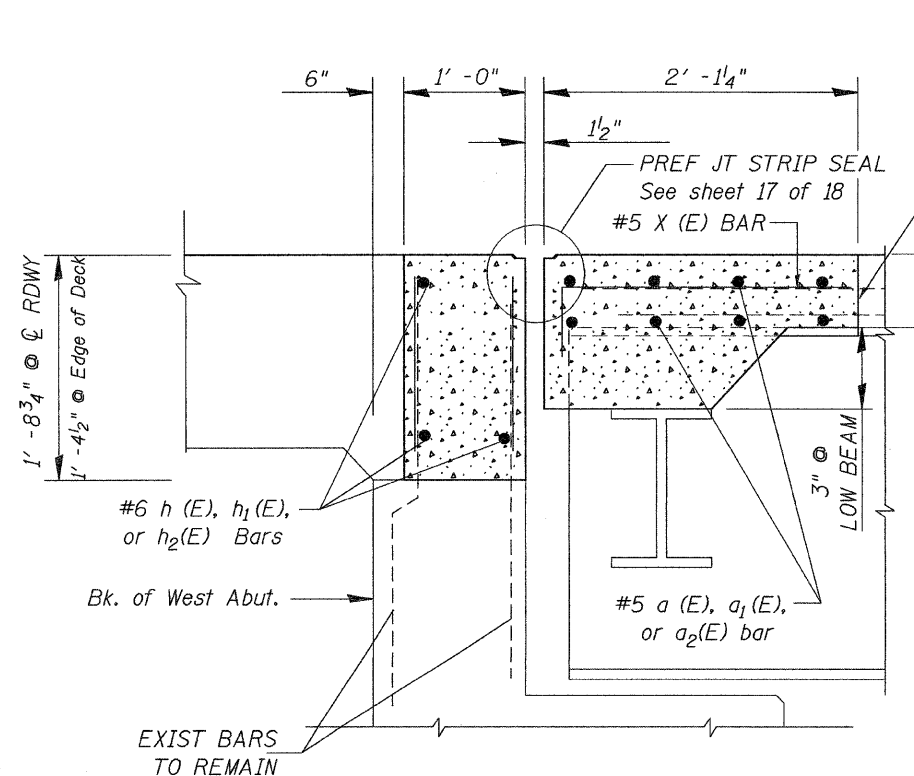

PROP SECTION THRU ABUTMENTS

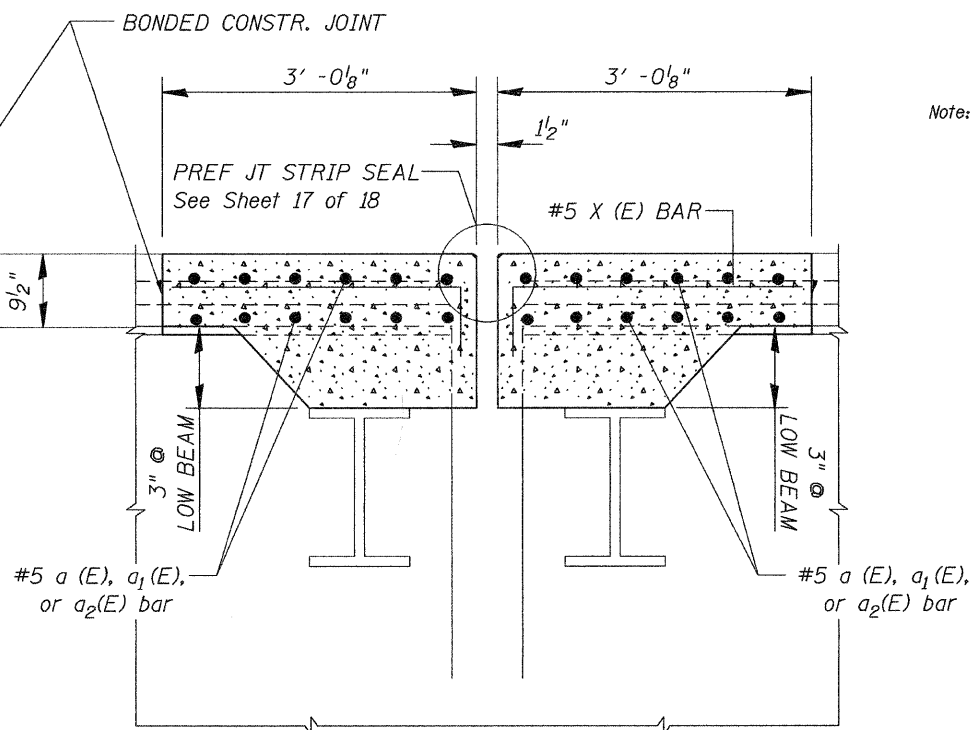

PROP SECTION THRU DECK JOINTS

Note: Dimensions are based on a Rolled Rail Strip Seal Joint. If the contractor elects to use the Welded Rail Strip Seal Joint, deck dimensions may require adjustments to satisfy the details on Base Sheet EJ-SSJ.

See sheet 9 of 18 for bar details.

JOINT DETAILS  
I-74 OVER 19th STREET  
FAI 74 (I-74)  
SECTION 81-(1-2,1,2-2)RS-1 & M  
ROCK ISLAND COUNTY  
STRUCTURE NUMBER 081-0099 (SB)

Sheet 8 of 18

FILE NAME = #FILEL#	USER NAME = #USER#	DESIGNED - -	REVISED - -	<b>STATE OF ILLINOIS DEPARTMENT OF TRANSPORTATION</b>	<b>JOINT DETAILS</b>	F.A.I. RTE.	SECTION	COUNTY	TOTAL SHEETS	SHEET NO.	
		DRAWN - -	REVISED - -			74	81-(1-2,1,2-2)RS-1 & M	ROCK ISLAND	246	137	
		CHECKED - -	REVISED - -			CONTRACT NO. 64A97		FED. ROAD DIST. NO. - ILLINOIS FED. AID PROJECT			
		DATE - -	REVISED - -								



# STAGING PLAN

STAGE I CONSTRUCTION  
Structure 081-0100 Northbound

569' - 3<sup>5</sup>/<sub>8</sub>" End to End of Deck

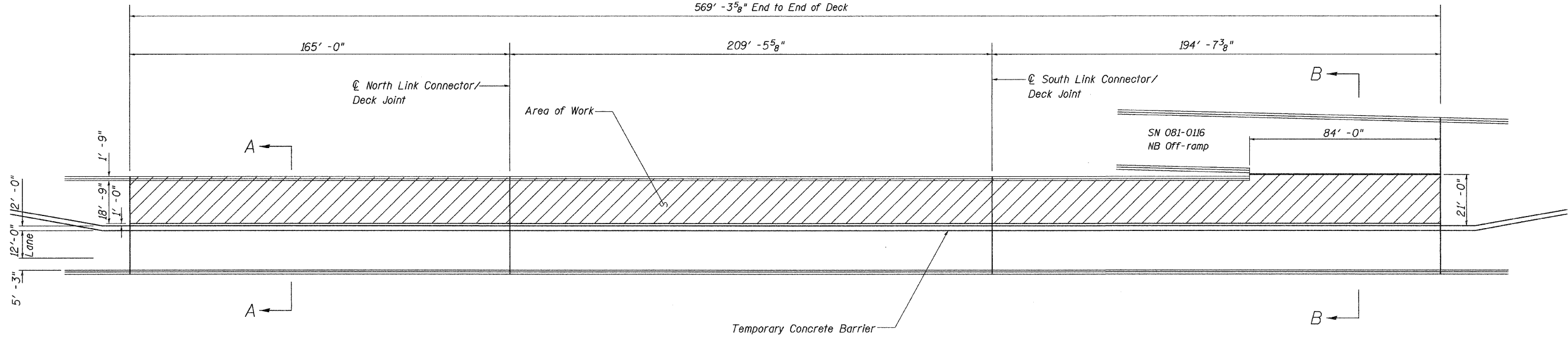

DECK PLAN - Structure 081-0100 Northbound

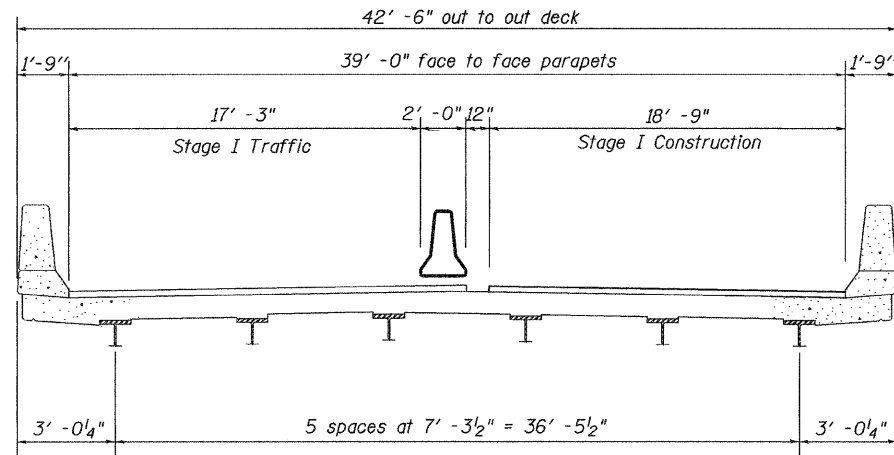

CROSS SECTION A-A Structure 081-0100 Northbound  
(Normal Section - Looking North)

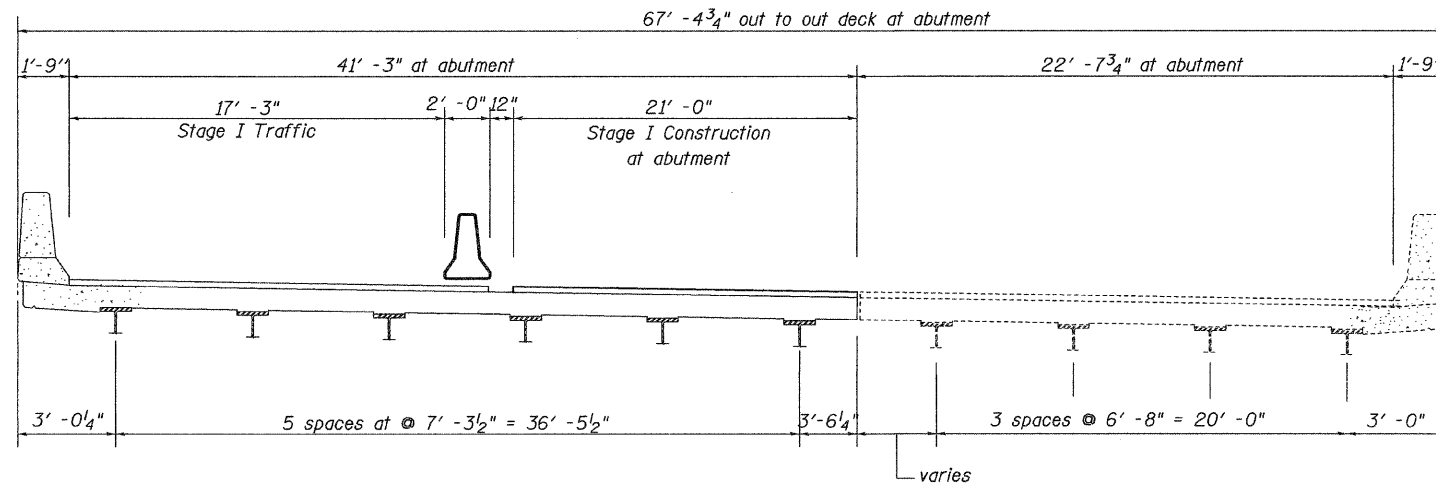

CROSS SECTION B-B Structure 081-0100 Northbound  
(At South Abutment - Looking North)

Structure 081-0116  
(Not part of this contract)

## STAGE I CONSTRUCTION

- Install Temporary Concrete Barrier.
- Move Traffic to Stage I Traffic.
- Sawcut concrete wearing surface.
- Replace bridge joints & repair deck.
- Install new wearing surface & waterproofing membrane.

Sheet 10 of 18

STAGING PLAN  
I-74 OVER 19th STREET  
FAI 74 (I-74)  
SECTION 81-(1-2,1,2-2)RS-1 & M  
ROCK ISLAND COUNTY  
STRUCTURE NUMBER 081-0100 (NB)

FILE NAME = #FILE#	USER NAME = #USER#	DESIGNED - -	REVISED - -	<b>STATE OF ILLINOIS DEPARTMENT OF TRANSPORTATION</b>	<b>STAGING PLAN</b>	F.A.I. RTE. 74	SECTION 81-(1-2,1,2-2)RS-1 & M	COUNTY ROCK ISLAND	TOTAL SHEETS 246	SHEET NO. 129	
	PLOT SCALE = #SCALE#	DRAWN - -	REVISED - -			SCALE: _____	SHEET NO. ____ OF ____ SHEETS	CONTRACT NO. 64A97		ILLINOIS FED. AID PROJECT	
	PLOT DATE = #DATE#	CHECKED - -	REVISED - -			STA. _____	TO STA. _____				
		DATE - -	REVISED - -								

# STAGING PLAN

STAGE II CONSTRUCTION  
Structure 081-0100 Northbound

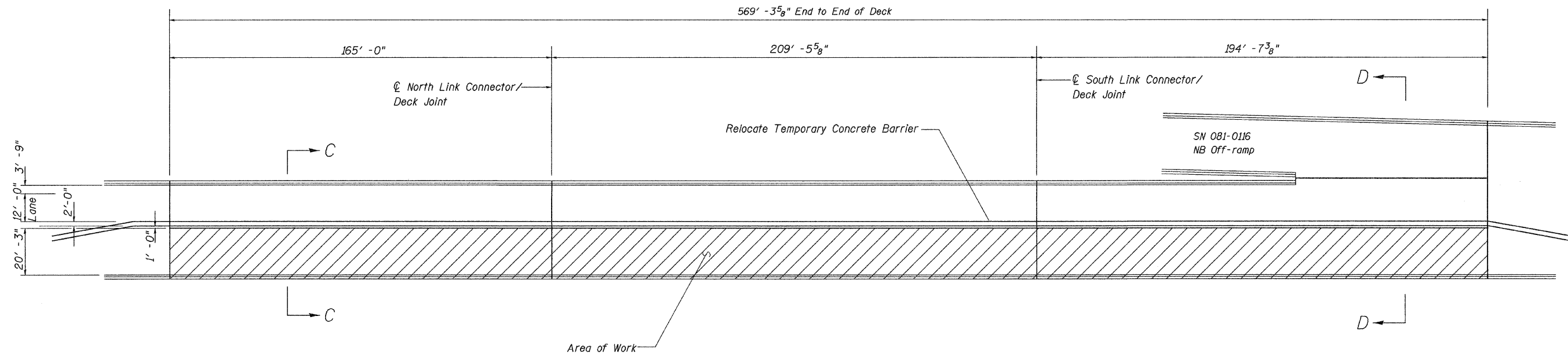

DECK PLAN - Structure 081-0100 Northbound

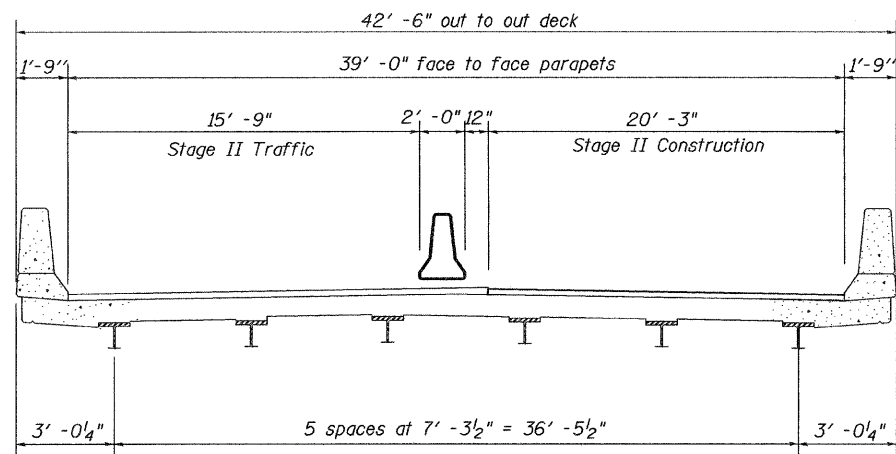

CROSS SECTION C-C Structure 081-0100 Northbound  
(Normal Section - Looking South)

### STAGE II CONSTRUCTION

- Relocate Temporary Concrete Barrier.
- Move Traffic to Stage II Traffic.
- Remove concrete wearing surface.
- Replace bridge joints & repair deck.
- Install new wearing surface & waterproofing membrane.
- Remove temporary concrete barrier.

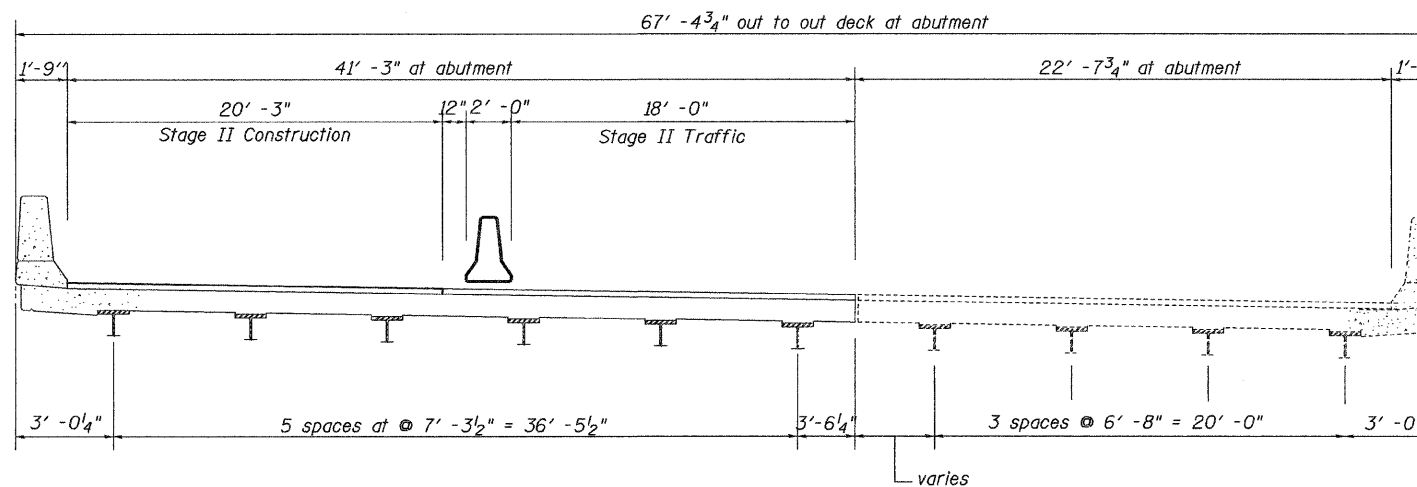

CROSS SECTION D-D Structure 081-0100 Northbound  
(Near South Abutment - Looking North)

Structure 081-0116  
(Not part of this contract)

STAGING PLAN  
I-74 OVER 19th STREET  
FAI 74 (I-74)  
SECTION 81-(1-2,1,2-2)RS-1 & M  
ROCK ISLAND COUNTY  
STRUCTURE NUMBER 081-0100 (NB)

Sheet 11 of 18

FILE NAME = #FILE#	USER NAME = #USER#	DESIGNED - -	REVISED - -	<b>STATE OF ILLINOIS DEPARTMENT OF TRANSPORTATION</b>	<b>STAGING PLAN</b>	F.A.I. RTE. 74	SECTION 81-(1-2,1,2-2)RS-1 & M	COUNTY ROCK ISLAND	TOTAL SHEETS 246	SHEET NO. 146	
	PLOT SCALE = #SCALE#	DRAWN - -	REVISED - -			SCALE: _____	SHEET NO. ____ OF ____ SHEETS	CONTRACT NO. 64A97		FED. ROAD DIST. NO. - [ILLINOIS] FED. AID PROJECT	
	PLOT DATE = #DATE#	CHECKED - -	REVISED - -			STA. _____	TO STA. _____				
		DATE - -	REVISED - -								



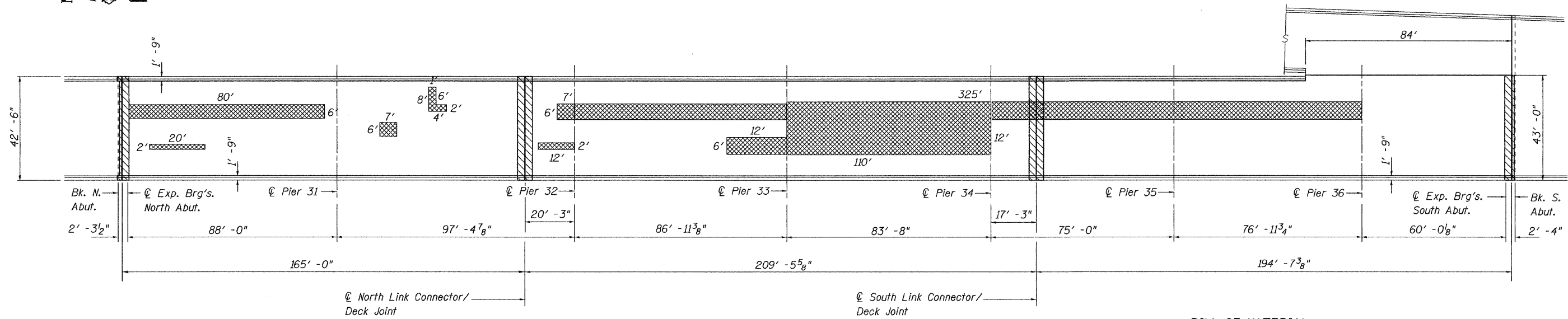

**Legend**

Potential Full Depth Deck Repair

Concrete Removal

Date of Survey: 05/02/2008

**BILL OF MATERIAL**

ITEM	UNIT	TOTAL
Polymerized HMA Surface Course Mix "E", N70	Ton	268
Waterproofing Membrane System	Sq Yd	2389
Bridge Deck Scarification	Sq Yd	2466
Protective Shield	Sq Yd	820

**DECK PLAN - Structure 081-0100 Northbound**

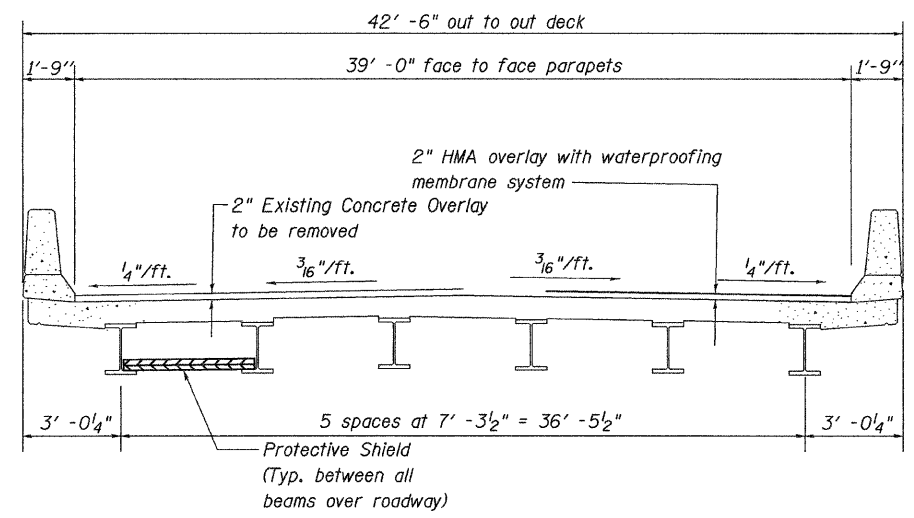

**CROSS SECTION - Structure 081-0100 Northbound**  
(Normal Section - Looking North)

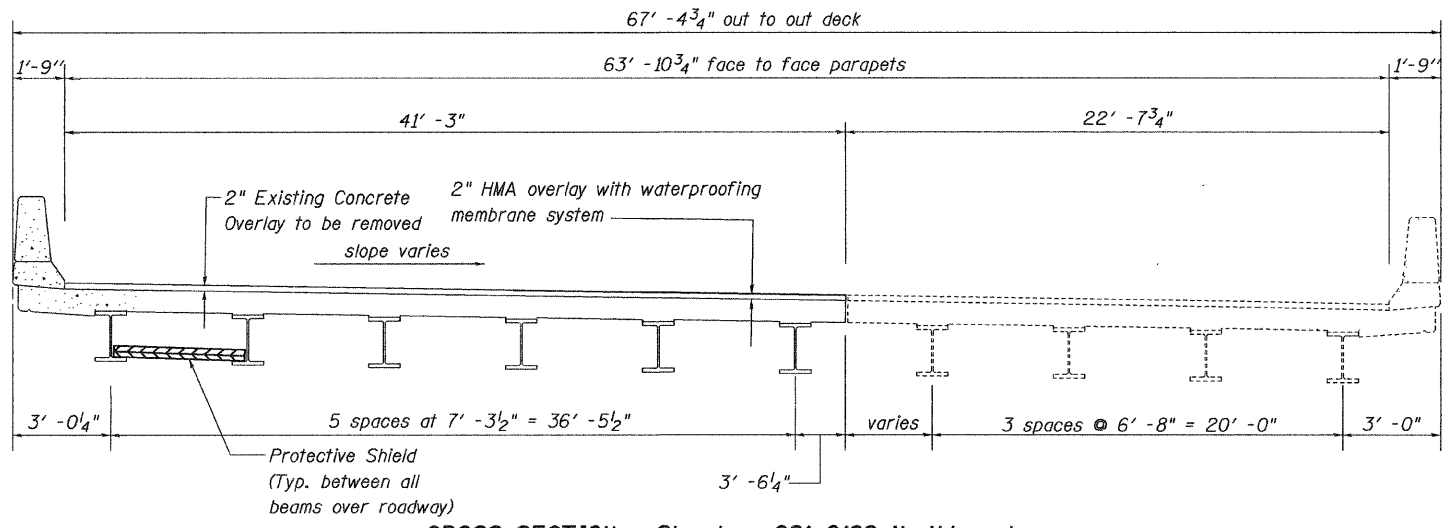

**CROSS SECTION - Structure 081-0100 Northbound**  
(At South Abutment - Looking North)

**DECK PLAN & CROSS-SECTION**  
**I-74 OVER 19th STREET**  
**FAI 74 (I-74)**  
**SECTION 81-(1-2,1,2-2)RS-1 & M**  
**ROCK ISLAND COUNTY**  
**STRUCTURE NUMBER 081-0100 (NB)**

Sheet 12 of 18

FILE NAME = #FILE#	USER NAME = #USER#	DESIGNED - -	REVISED - -	<b>STATE OF ILLINOIS DEPARTMENT OF TRANSPORTATION</b>	<b>STAGING PLAN</b>	F.A.I. RTE. 74	SECTION 81-(1-2,1,2-2)RS-1 & M	COUNTY ROCK ISLAND	TOTAL SHEETS 246	SHEET NO. 141	
	PLOT SCALE = #SCALE#	DRAWN - -	REVISED - -			SCALE: _____	SHEET NO. ____ OF ____ SHEETS	STA. _____ TO STA. _____	CONTRACT NO. 64A97		FED. ROAD DIST. NO. - [ILLINOIS] FED. AID PROJECT
	PLOT DATE = #DATE#	CHECKED - -	REVISED - -								
		DATE - -	REVISED - -								

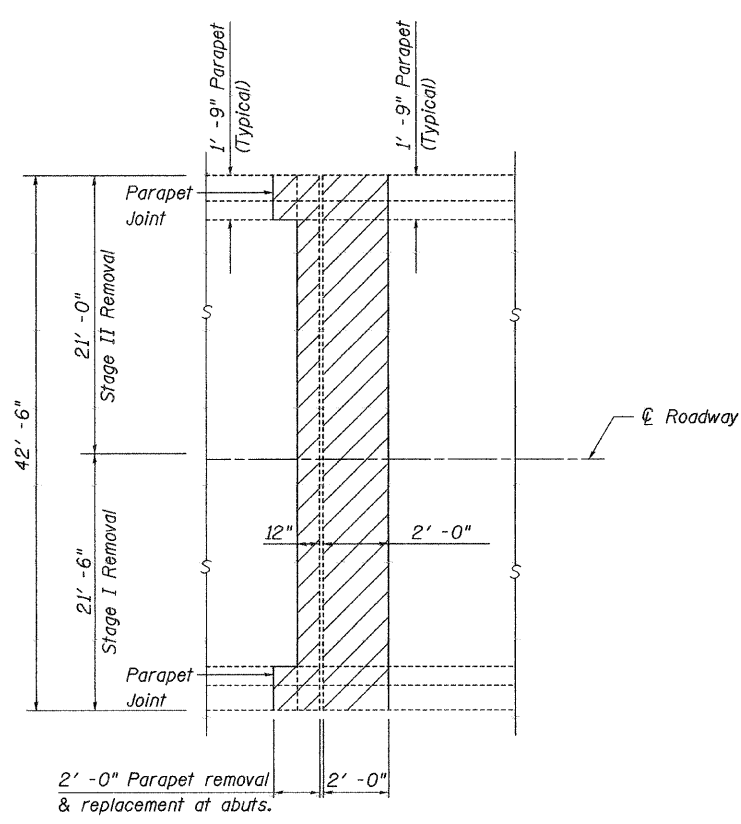

**EXISTING PARTIAL PLAN**  
(North Abutment)

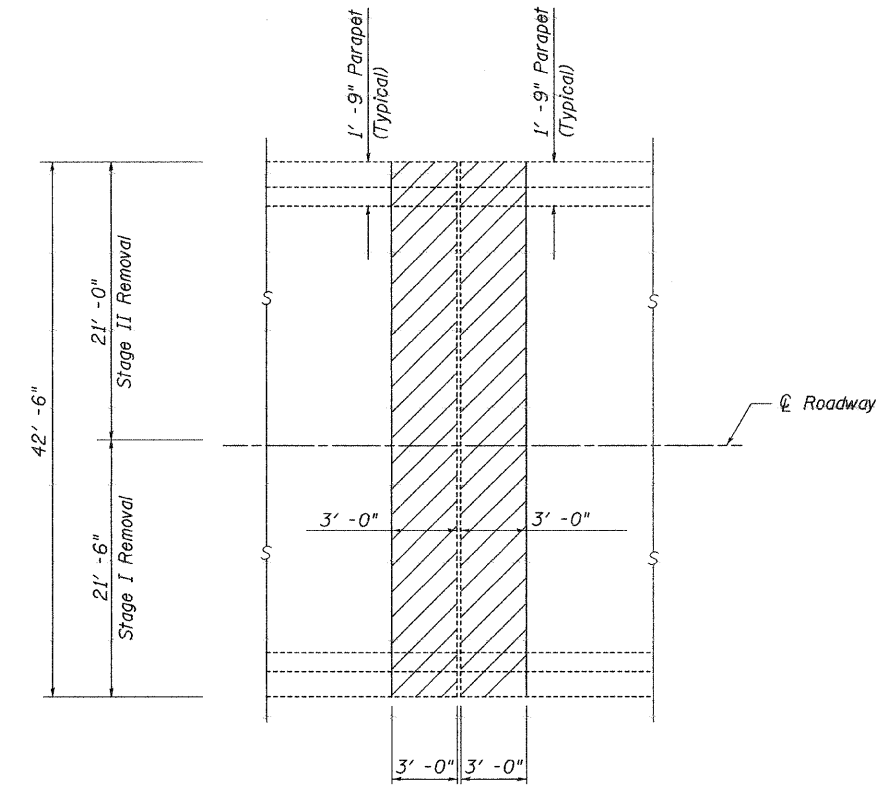

**EXISTING PARTIAL PLAN**  
(North Link Connection)

See sheet 16 of 18 for bar details.

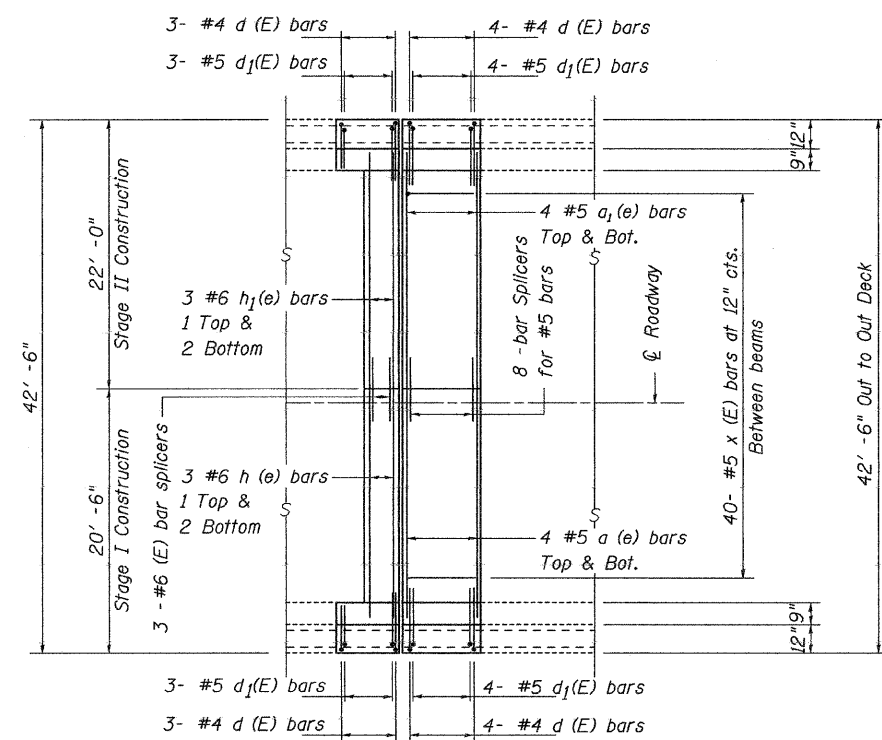

**PROPOSED PARTIAL PLAN**  
(North Abutment)

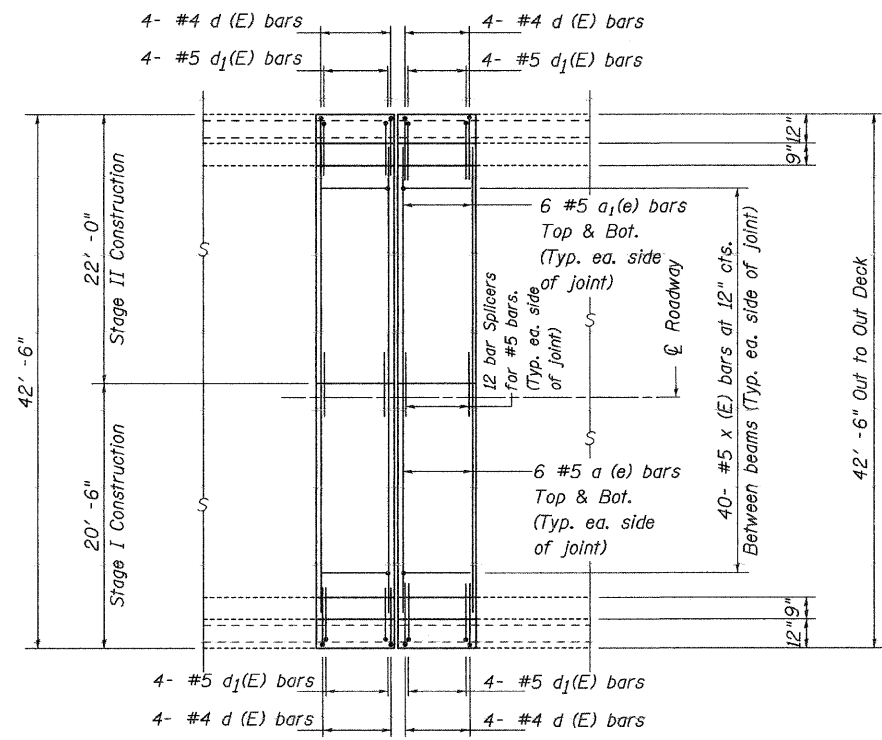

**PROPOSED PARTIAL PLAN**  
(North Link Connection)

**JOINT DETAILS**  
 I-74 OVER 19th STREET  
 FAI 74 (I-74)  
 SECTION 81-(1-2,1,2-2)RS-1 & M  
 ROCK ISLAND COUNTY  
 STRUCTURE NUMBER 081-0100 (NB)

FILE NAME =	USER NAME = #USER#	DESIGNED -	REVISED -	<b>STATE OF ILLINOIS DEPARTMENT OF TRANSPORTATION</b>	<b>JOINT DETAILS</b>	F.A.I. RTE.	SECTION	COUNTY	TOTAL SHEETS	SHEET NO.
#FILE#		DRAWN -	REVISED -			74	81-(1-2,1,2-2)RS-1 & M	ROCK ISLAND	146	142
PLOT SCALE = #SCALE#		CHECKED -	REVISED -			CONTRACT NO. 64A97				
PLOT DATE = #DATE#		DATE -	REVISED -			FED. ROAD DIST. NO. - ILLINOIS FED. AID PROJECT				
						SCALE: _____	SHEET NO. ____ OF ____ SHEETS	STA. _____ TO STA. _____		

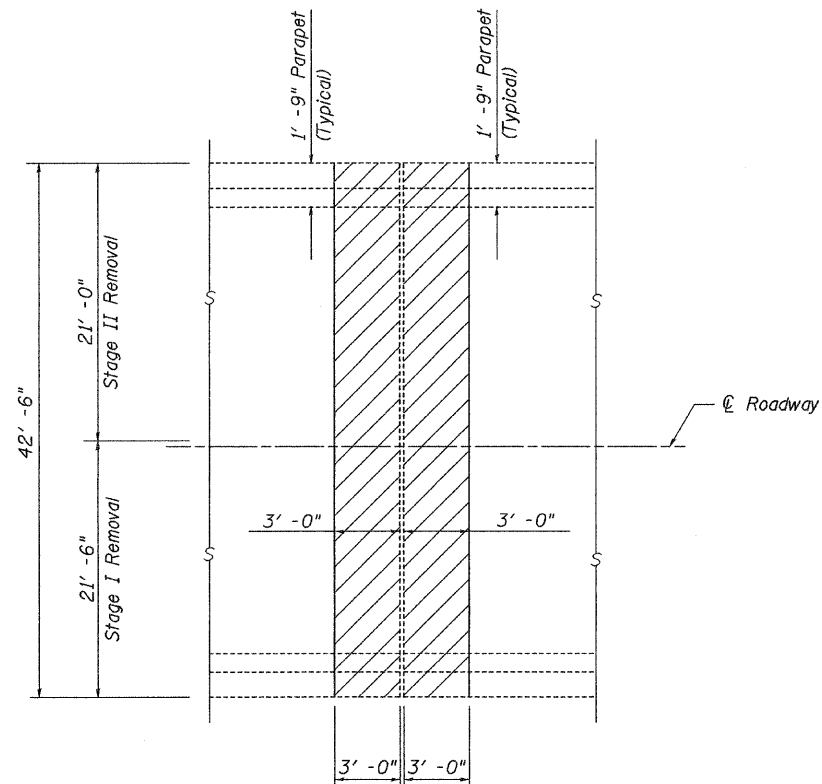

**EXISTING PARTIAL PLAN**  
(South Link Connection)

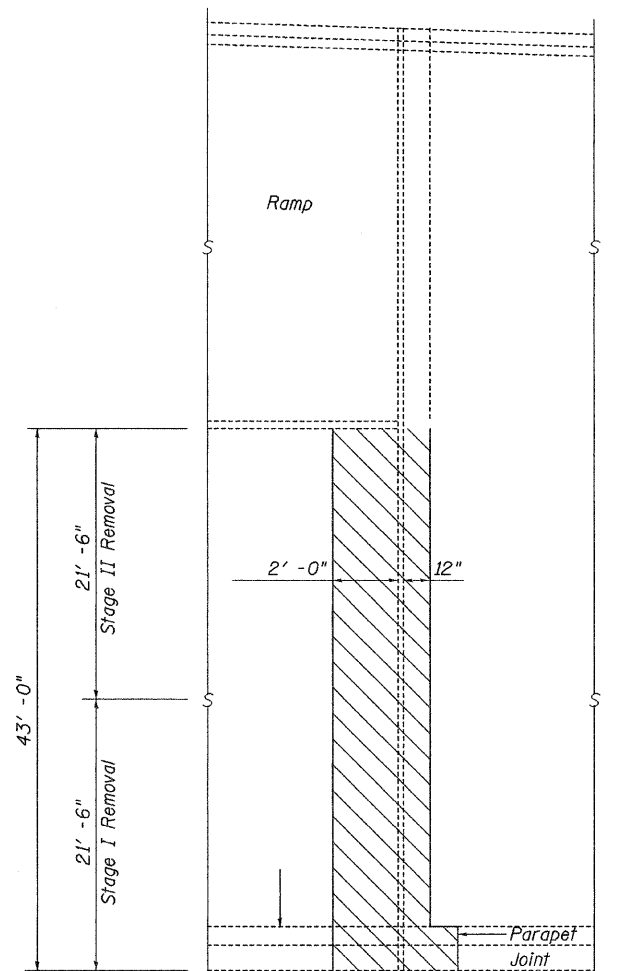

**EXISTING PARTIAL PLAN**  
(South Abutment)

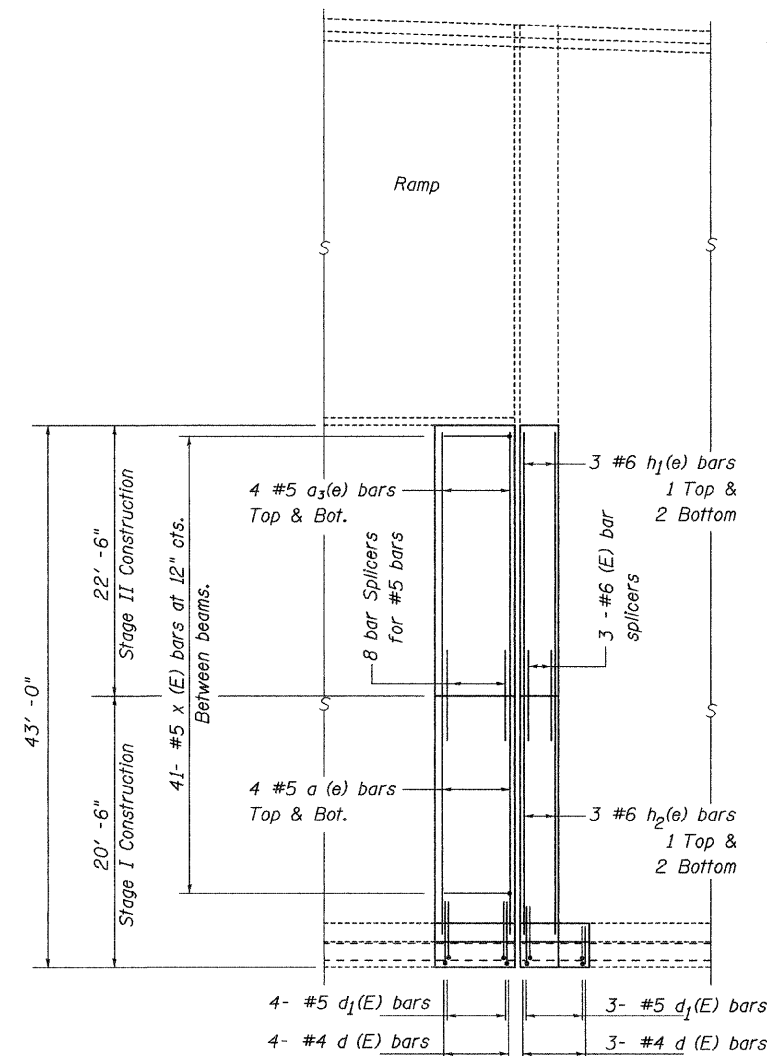

**PROPOSED PARTIAL PLAN**  
(South Abutment)

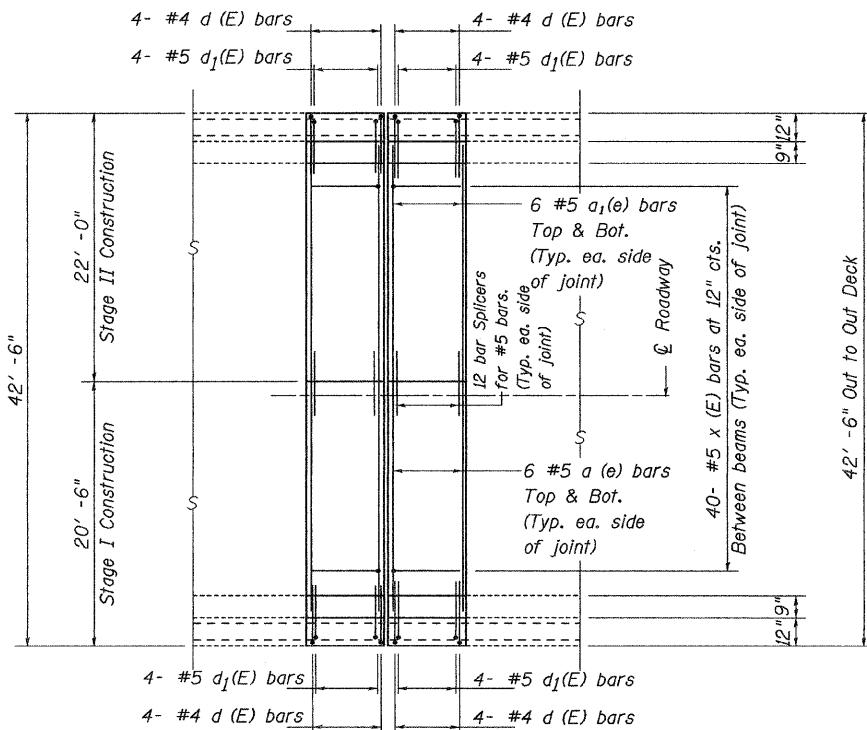

**PROPOSED PARTIAL PLAN**  
(South Link Connection)

See sheet 16 of 18  
for bar details.

**JOINT DETAILS**  
**I-74 OVER 19th STREET**  
**FAI 74 (I-74)**  
**SECTION 81-(1-2,1,2-2)RS-1 & M**  
**ROCK ISLAND COUNTY**  
**STRUCTURE NUMBER 081-0100 (NB)**

Sheet 14 of 18

FILE NAME =	USER NAME = #USER#	DESIGNED - -	REVISED - -	<b>STATE OF ILLINOIS</b> <b>DEPARTMENT OF TRANSPORTATION</b>	<b>Joint Details</b>	F.A.I. RTE.	SECTION	COUNTY	TOTAL SHEETS	SHEET NO.	
#FILE#		DRAWN - -	REVISED - -			74	81-(1-2,1,2-2)RS-1 & M	ROCK ISLAND	146	142	
		CHECKED - -	REVISED - -			CONTRACT NO. 64A97		FED. ROAD DIST. NO. - ILLINOIS FED. AID PROJECT			
		DATE - -	REVISED - -			SCALE: _____ SHEET NO. ___ OF ___ SHEETS STA. _____ TO STA. _____					

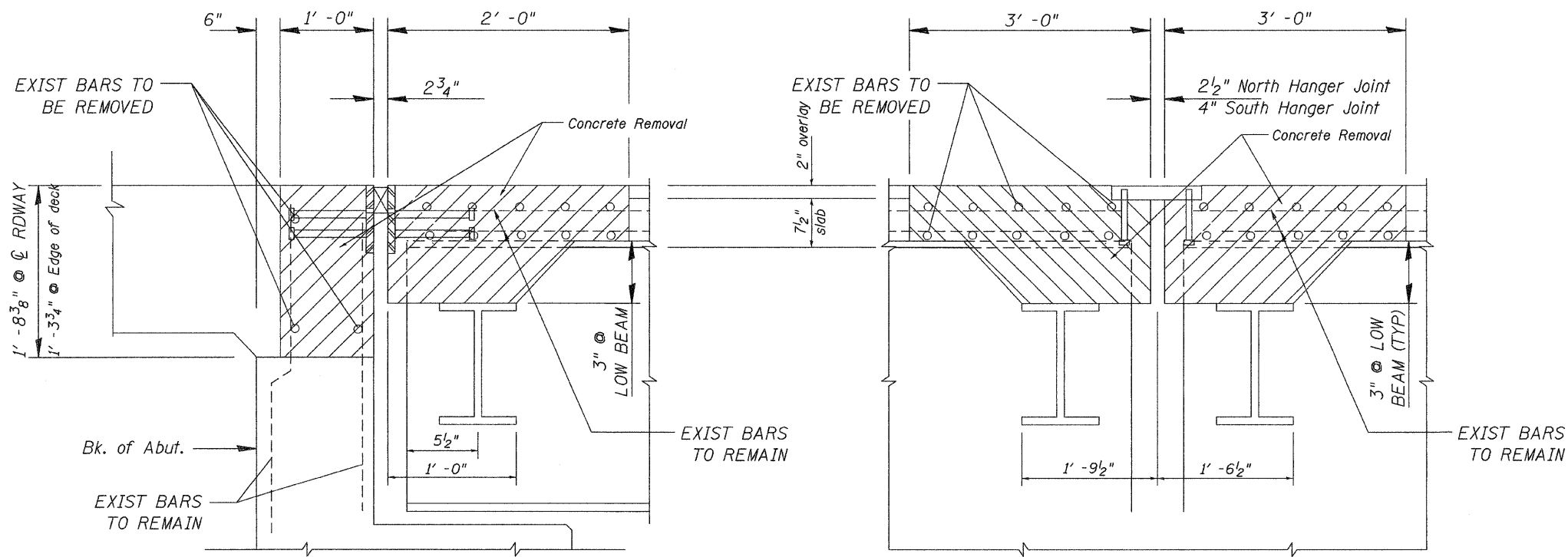

EXIST SECTION THRU ABUTMENTS

EXIST SECTION THRU DECK JOINTS  
(Looking East)

Note: Dimensions are based on a Rolled Rail Strip Seal Joint. If the contractor elects to use the Welded Rail Strip Seal Joint, deck dimensions may require adjustments to satisfy the details on Base Sheet EJ-SSJ.

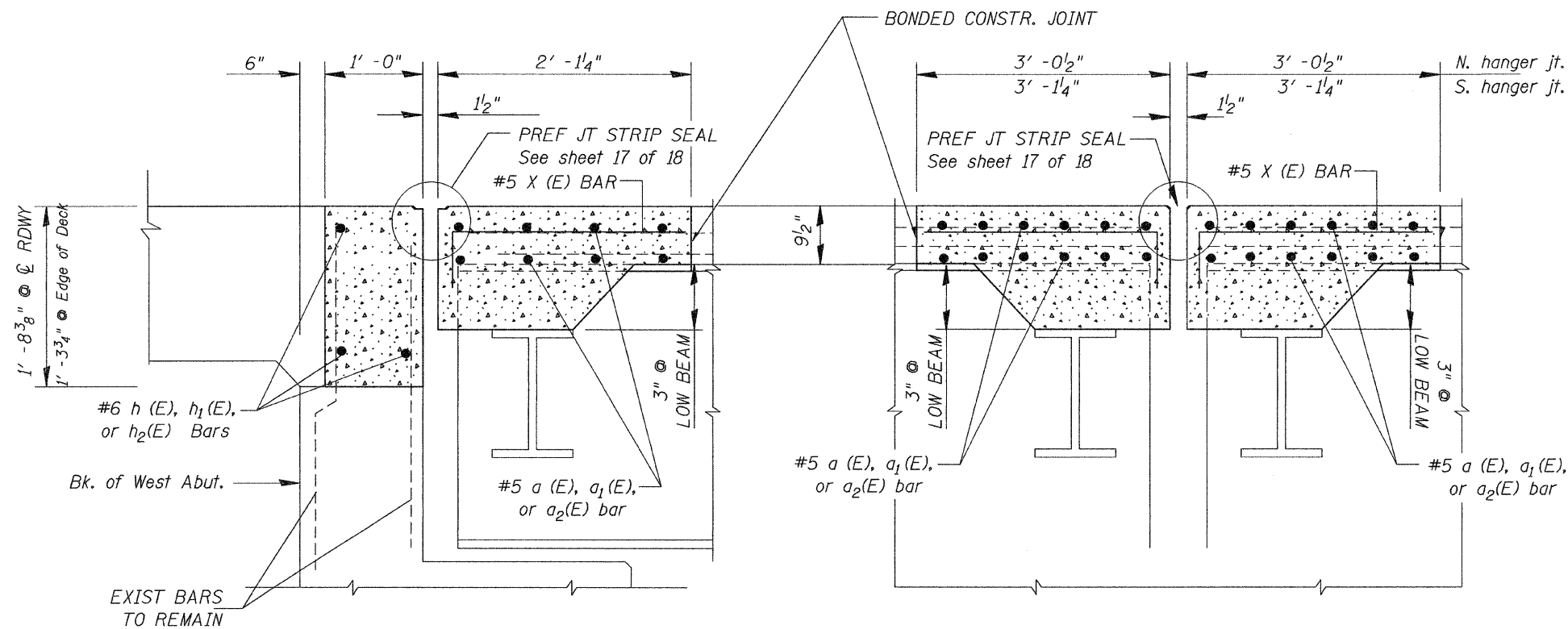

See sheet 16 of 18 for bar details.

PROP SECTION THRU ABUTMENTS

PROP SECTION THRU DECK JOINTS

JOINT DETAILS  
I-74 OVER 19th STREET  
FAI 74 (I-74)  
SECTION 81-(1-2,1,2-2)RS-1 & M  
ROCK ISLAND COUNTY  
STRUCTURE NUMBER 081-0100 (NB)

Sheet 15 of 18

FILE NAME = #FILE#	USER NAME = #USER#	DESIGNED - -	REVISED - -	<b>STATE OF ILLINOIS DEPARTMENT OF TRANSPORTATION</b>	<b>JOINT DETAILS</b>	F.A.I. RTE.	SECTION	COUNTY	TOTAL SHEETS	SHEET NO.	
	PLOT SCALE = #SCALE#	DRAWN - -	REVISED - -			74	81-(1-2,1,2-2)RS-1 & M	ROCK ISLAND	246	144	
	PLOT DATE = #DATE#	CHECKED - -	REVISED - -			CONTRACT NO. 64A97		FED. ROAD DIST. NO. - ILLINOIS FED. AID PROJECT			
		DATE - -	REVISED - -			SCALE: _____	SHEET NO. ____ OF ____ SHEETS	STA. _____ TO STA. _____			

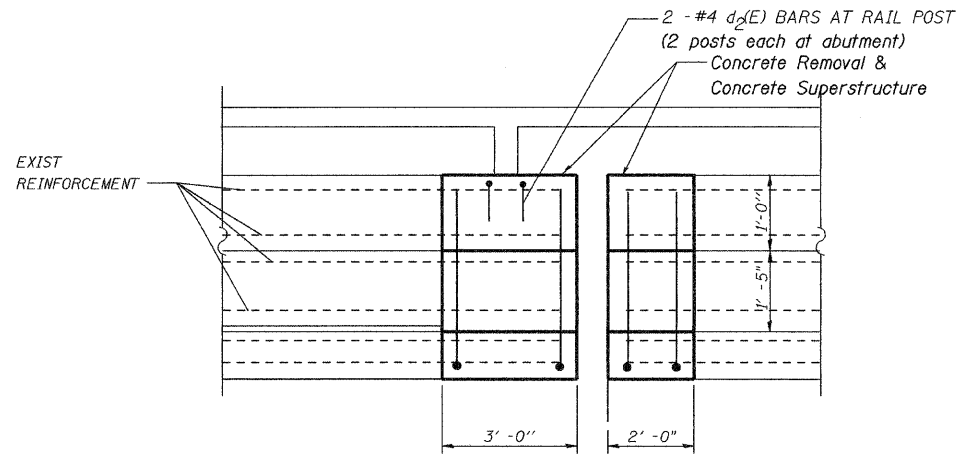

INSIDE VIEW OF PARAPET AT ABUTMENTS

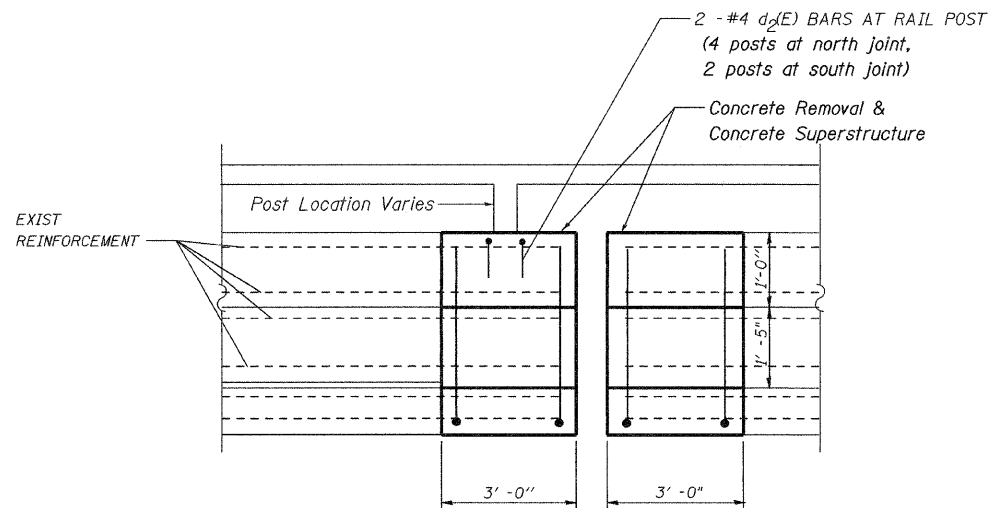

INSIDE VIEW OF PARAPET AT LINK CONNECTOR JOINTS

NOTE: ALL COST FOR REMOVAL OF EXISTING ALUMINUM RAILING AND RAIL ELEMENTS, IF REQUIRED, AND RE-INSTALLATION SHALL BE CONSIDERED INCLUDED IN CONCRETE REMOVAL

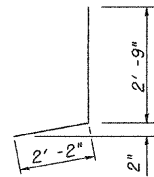

#4 d(E) BAR

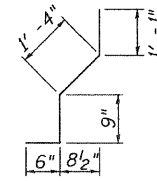

#5 d1(E) BAR

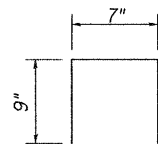

#4 d2(E) BAR

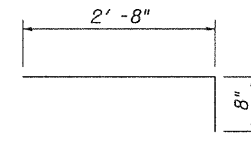

#4 x(E) BAR

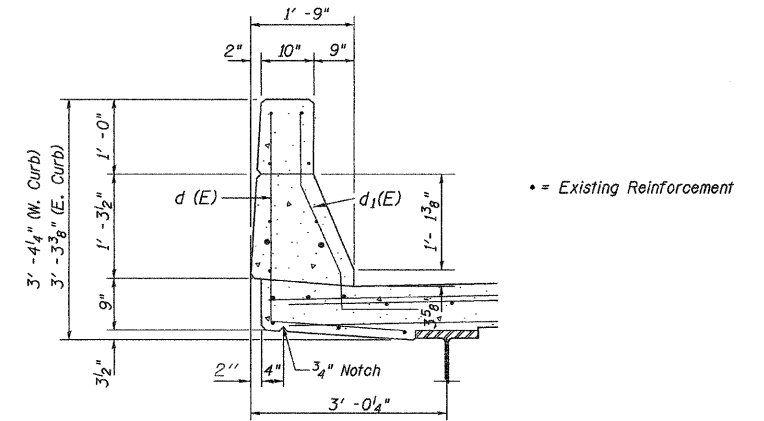

TYPICAL SECTION THRU PARAPET

Bill of Material  
(Northbound structure)

BAR	NO.	SIZE	LENGTH	SHAPE	
a (E)	64	5	20' - 2"	—	
a1(E)	56	5	21' - 8"	—	
a3(E)	8	5	22' - 2"	—	
d (E)	53	4	4' - 11"	┘	
d1(E)	53	5	3' - 8"	┘	
d2(E)	20	4	2' - 1"	┘	
h (E)	6	6	20' - 2"	—	
h1(E)	6	6	21' - 8"	—	
h2(E)	6	6	18' - 2"	—	
x (E)	241	5	3' - 4"	┘	
CONCRETE SUPERSTRUCTURE				CU YD	37.5
CONCRETE REMOVAL				CU YD	37.5
REINFORCEMENT BARS, EPOXY COATED				POUND	4580
PREFORMED JOINT STRIP SEAL				FOOT	170
BAR SPLICERS				EACH	70
REM REIN T B TERM T6				EACH	3

Notes:  
Remove and reuse railing, including posts and anchors, where concrete removal affects existing rail posts. Cost included with Concrete Superstructure. If anchors are damaged during construction, they shall be replaced and are included with Concrete Removal.

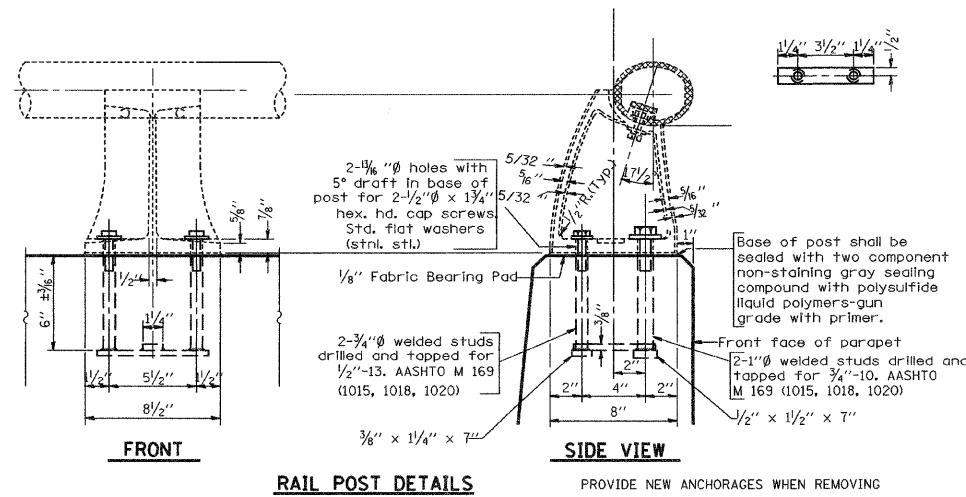

DECK DETAILS  
I-74 OVER 19th STREET  
FAI 74 (I-74)  
SECTION 81-(1-2,1,2-2)RS-1 & M  
ROCK ISLAND COUNTY  
STRUCTURE NUMBER 081-0100 (NB)

FILE NAME = #FILE#	USER NAME = #USER#	DESIGNED - -	REVISED - -	STATE OF ILLINOIS DEPARTMENT OF TRANSPORTATION	DECK DETAILS	F.A.I. RTE. 74	SECTION 81-(1-2,1,2-2)RS-1 & M	COUNTY ROCK ISLAND	TOTAL SHEETS 246	SHEET NO. 145	
PLOT SCALE = #SCALE#	DRAWN - -	REVISOR - -	SCALE: _____			SHEET NO. _____ OF _____ SHEETS	STA. _____ TO STA. _____	CONTRACT NO. 64A97		FED. ROAD DIST. NO. - ILLINOIS FED. AID PROJECT	
PLOT DATE = #DATE#	CHECKED - -	REVISOR - -									
	DATE - -	REVISOR - -									

\* Granular or solid flux filled headed studs conforming to Article 1006.32 of the Std. Specs., automatically end welded.

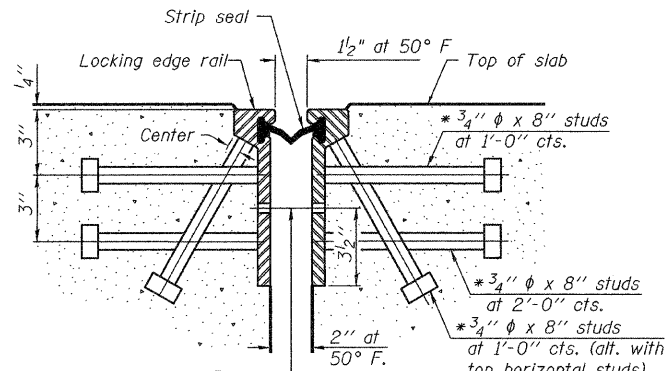

7/16" diameter holes at 4'-0" cts. for 3/8" diameter bolts. All bolts shall be burned, sawed, or chipped off flush with the plates after forms are removed, typ.

**SECTION THRU ROLLED RAIL JOINT**

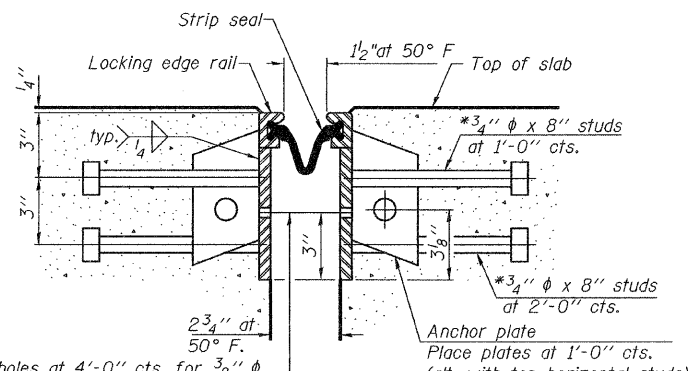

7/16" diameter holes at 4'-0" cts. for 3/8" diameter bolts. All bolts shall be burned, sawed, or chipped off flush with the plates after forms are removed, typ.

**SECTION THRU WELDED RAIL JOINT**

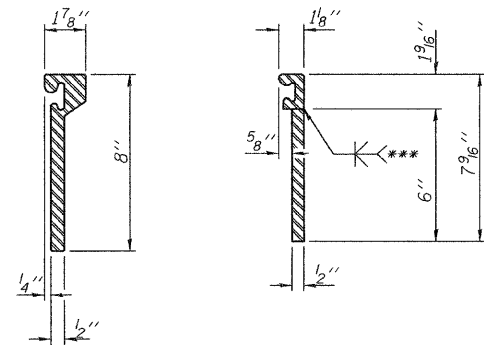

**ROLLED EXTRUDED RAIL WELDED RAIL**

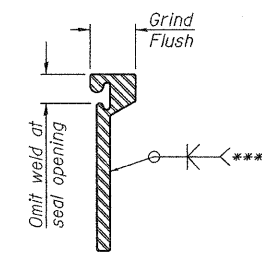

\*\*\*Back gouge not required if complete joint penetration is verified by mock-up.

**LOCKING EDGE RAIL SPLICE**

The inside of the locking edge rail groove shall be free of weld residue.

**LOCKING EDGE RAILS**

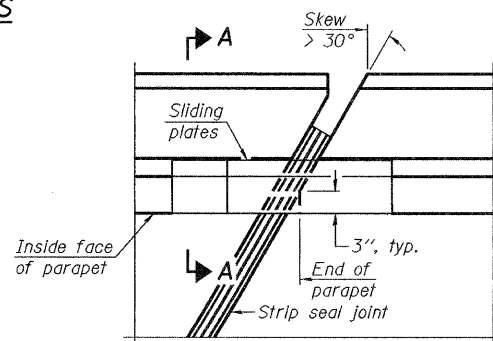

**PLAN**

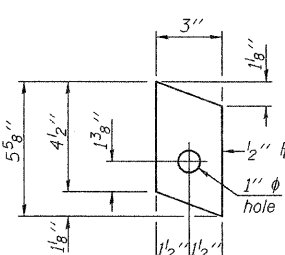

**ANCHOR PLATE (for welded rail)**

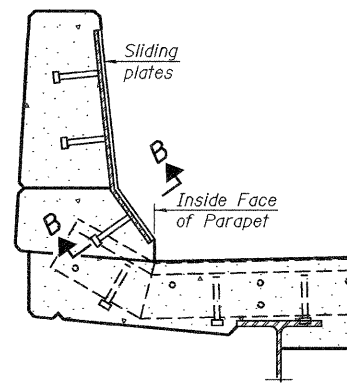

**SECTION A-A**

**POINT BLOCK DETAILS (for skews > 30°)**

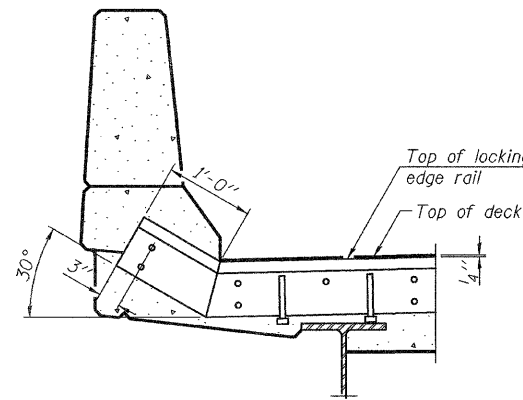

**AT PARAPET**

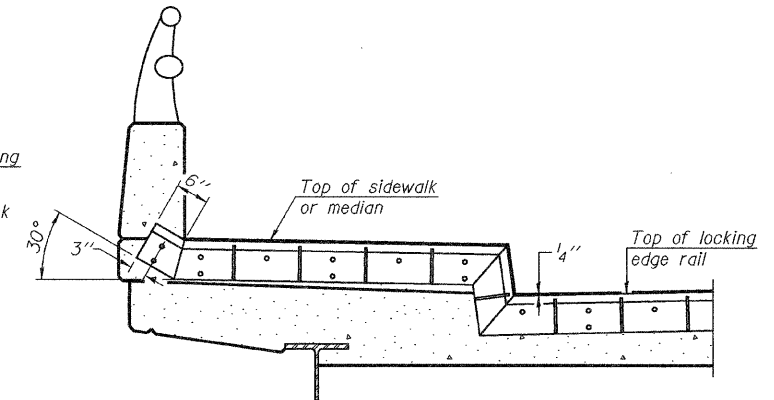

**AT SIDEWALK OR MEDIAN**

Shorter plates with a single row of studs at 12" cts. may be necessary on medians which are shallower than 9". See manufacturer's recommendation.

**TYPICAL END TREATMENTS**

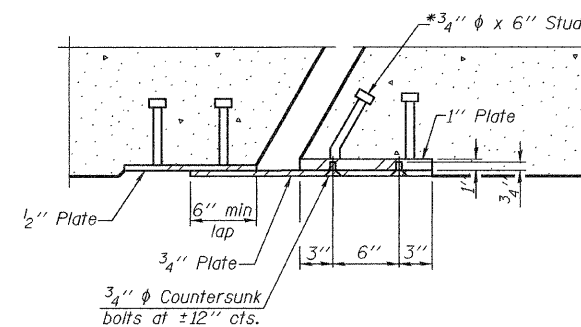

**SECTION B-B**

**BILL OF MATERIAL**

Item	Unit	Total
Preformed Joint Strip Seal	Foot	340

**STRIP SEAL JOINT  
I-74 OVER 19th STREET  
FAI 74 (I-74)  
SECTION 81-(1-2,1,2-2)RS-1 & M  
ROCK ISLAND COUNTY  
STRUCTURE NUMBER 081-0099 (SB) and  
081-0100 (NB)**

FILE NAME =	USER NAME = #USER#	DESIGNED -	REVISED -
#FILE#		DRAWN -	REVISED -
		CHECKED -	REVISED -
		DATE -	REVISED -

F.A.I. RTE.	SECTION	COUNTY	TOTAL SHEETS	SHEET NO.
74	81-(1-2,1,2-2)RS-1 & M	ROCK ISLAND	246	146
		ILLINOIS		CONTRACT NO. 64A97

The diameter of this part is the same as the diameter of the bar spliced.

The diameter of this part is equal or larger than the diameter of bar spliced.

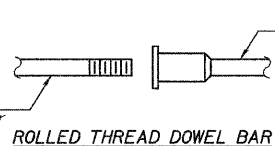

**ROLLED THREAD DOWEL BAR**

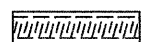

**\*\* ONE PIECE**

Wire Connector

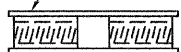

**WELDED SECTIONS**

**BAR SPLICER ASSEMBLY ALTERNATIVES**

\*\*Heavy Hex Nuts conforming to ASTM A 563, Grade C, D or DH may be used.

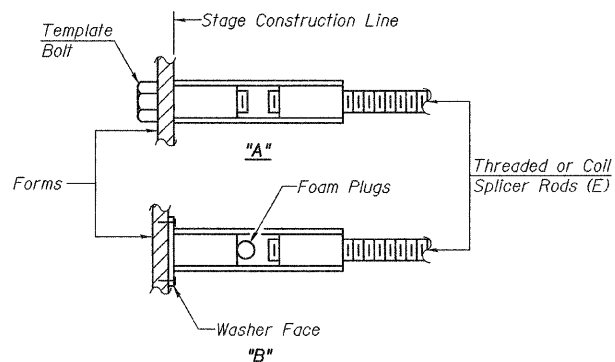

**INSTALLATION AND SETTING METHODS**

"A" : Set bar splicer assembly by means of a template bolt.  
 "B" : Set bar splicer assembly by nailing to wood forms or cementing to steel forms.  
 (E) : Indicates epoxy coating.

**NOTES**  
 Bar splicer assemblies shall be of an approved type and shall develop in tension at least 125 percent of the yield strength of the lapped reinforcement bars.  
 Splicer rods shall be of minimum 60 ksi yield strength, threaded or coiled full length.  
 All reinforcement bars shall be lapped and tied to the splicer rods or dowel bars.  
 Bar splicer assemblies shall be epoxy coated according to the requirements for reinforcement bars.  
 Other systems of similar design may be submitted to the Engineer for approval. Approval shall be based on certified test results from an approved testing laboratory that the proposed bar splicer assembly satisfies the following requirements:

- ① Minimum Capacity =  $1.25 \times f_y \times A_s$   
 (Tension in kips)
  - ② Minimum \*Pull-out Strength =  $0.66 \times f_y \times A_s$   
 (Tension in kips)
- Where  $f_y$  = Yield strength of lapped reinforcement bars in ksi.  
 $A_s$  = Tensile stress area of lapped reinforcement bars.  
 \* = 28 day concrete

BAR SPLICER ASSEMBLIES			
Bar Size to be Spliced	Splicer Rod or Dowel Bar Length	Strength Requirements	
		Min. Capacity kips - tension	Min. Pull-Out Strength kips - tension
#4	1'-8"	14.7	7.9
#5	2'-2"	23.0	12.3
#6	2'-7"	33.1	17.4
#7	3'-5"	45.1	23.8
#8	4'-6"	58.9	31.3
#9	5'-9"	75.0	39.6
#10	7'-3"	95.0	50.3
#11	9'-0"	117.4	61.8

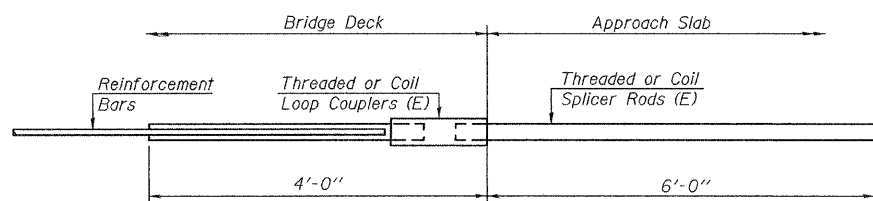

**FOR INTEGRAL OR SEMI-INTEGRAL ABUTMENTS**

Bar Splicer for #5 bar	
Min. Capacity = 23.0 kips - tension	
Min. Pull-out Strength = 12.3 kips - tension	
No. Required =	

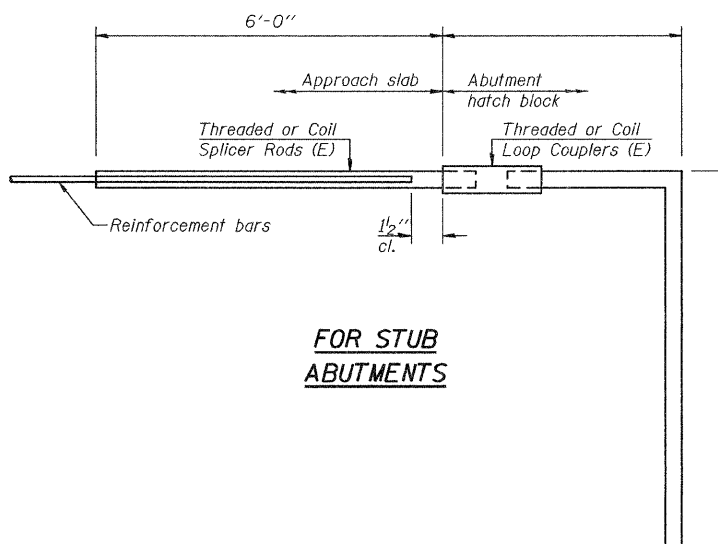

**FOR STUB ABUTMENTS**

Bar Splicer for #5 bar	
Min. Capacity = 23.0 kips - tension	
Min. Pull-out Strength = 12.3 kips - tension	
No. Required =	

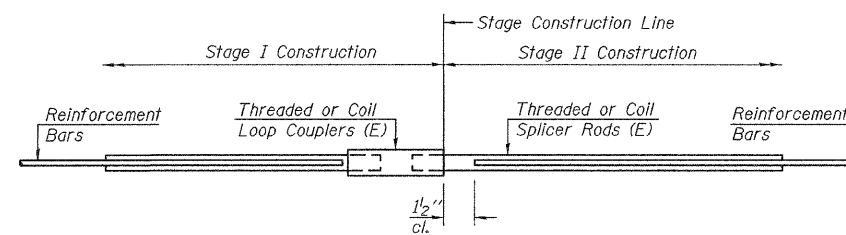

**STANDARD**

Bar Size	No. Assemblies Required	Location
#5	128	Deck
#6	12	Abutments

**BAR SPLICER ASSEMBLY DETAILS**  
**I-74 OVER 19th STREET**  
**FAI 74 (I-74)**  
**SECTION 81-(1-2,1,2-2)RS-1 & M**  
**ROCK ISLAND COUNTY**  
**STRUCTURE NUMBER 081-0099 (SB) and 081-0100 (NB)**

Sheet 18 of 18

STATE OF ILLINOIS  
DEPARTMENT OF TRANSPORTATION

ROUTE NO.	SECTION	COUNTY	TOTAL SHEETS	SHEET NO.	SHEET NO. 1
FAI 74	*	ROCK ISLAND	246	148	10 SHEETS
FED. ROAD DIST. NO. 7	ILLINOIS	FED. AID PROJECT			

\* 81 (1-2, 1, 2-2) RS-1 & M

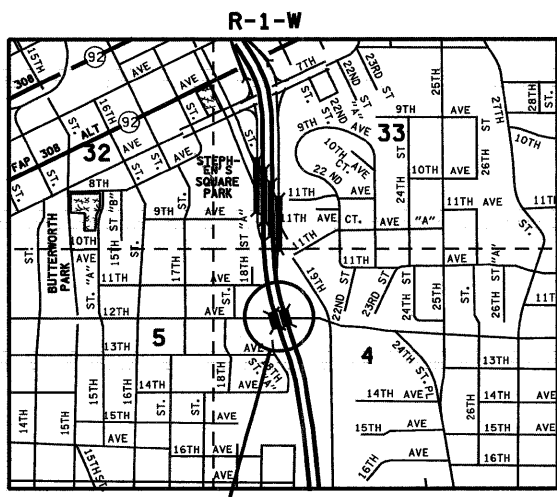
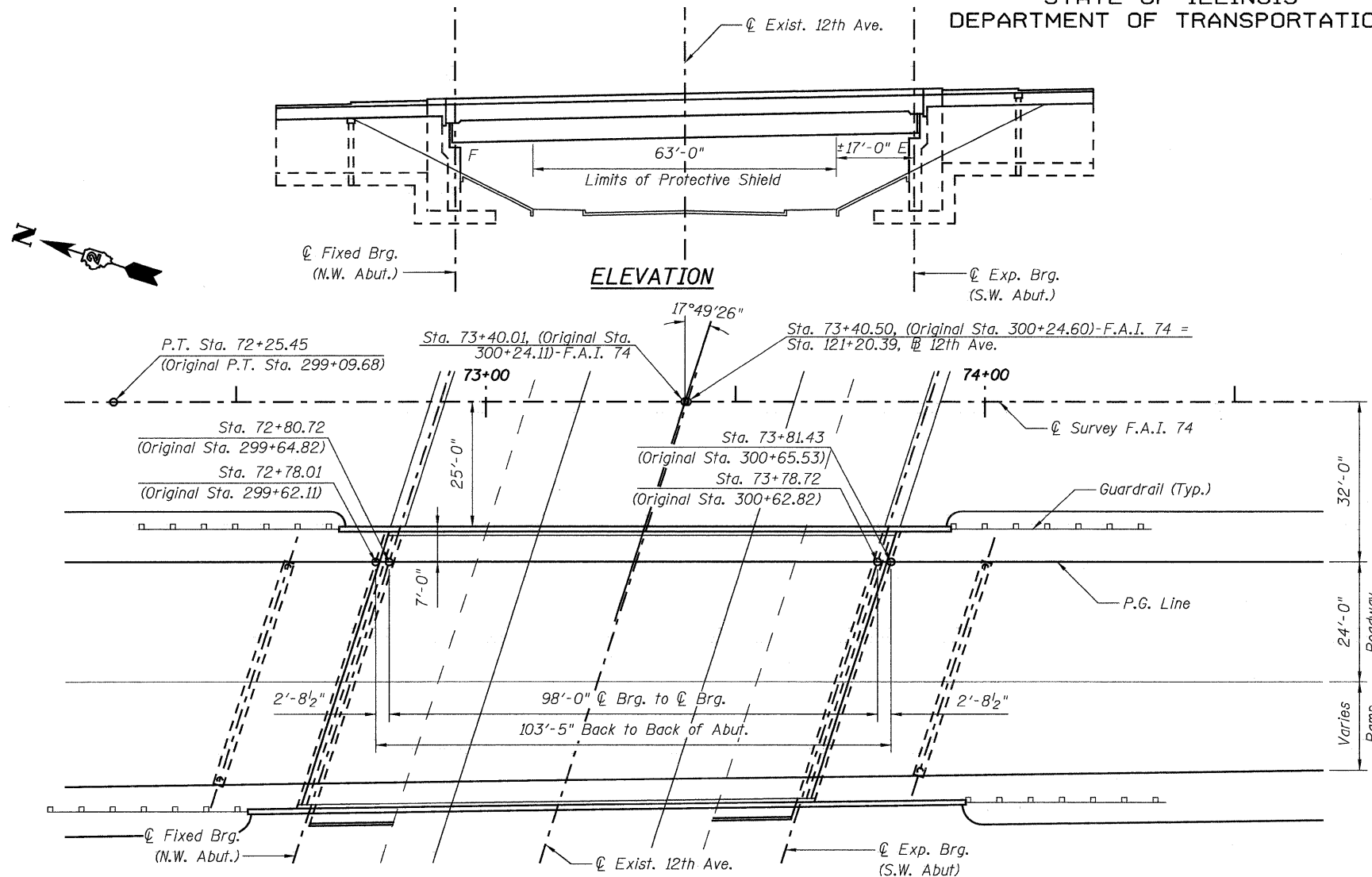

PROJECT LOCATION  
LOCATION PLAN

DESIGNED	DFM
CHECKED	DSG
DRAWN	EBS
CHECKED	DFM

**PLAN**  
**GENERAL NOTES**

Existing reinforcement bars extending into the removal area shall be cleaned, straightened and incorporated into the new construction. Any reinforcement bars that are damaged during concrete removal shall be replaced with approved bar splicer or anchorage system. Cost included with Concrete Removal.

No field welding is permitted except as specified in the contract documents.

Reinforcement bars shall conform to the requirements of ASTM A706 Grade 60. See Special Provisions.

Reinforcement bars designated (E) shall be epoxy coated.

Plan dimensions and details relative to existing plans are subject to routine variations. The Contractor shall field verify existing dimensions and details affecting new construction and make necessary approved adjustments prior to construction or ordering materials. Such variations shall not be cause for additional compensation for a change in scope of work, however, the Contractor will be paid for the quantity actually furnished at the unit price bid for work.

Prior to pouring the new concrete deck, all heavy or loose rust, loose mill scale, and all other loose, potentially detrimental foreign material shall be removed from the surfaces in contact with concrete. Tightly adhered paint may remain unless otherwise noted. Removal shall be accomplished by methods that will not damage the steel and the cost will be included in the pay item covering removal of the existing concrete.

As directed by the Engineer, existing construction accessories welded to the top flange of beams and girders shall be removed. The weld areas shall be ground flush and inspected for cracks using magnetic particle testing (MT) or dye penetrant testing (PT) by an individual acceptable to the Engineer. Any cracks that can not be removed by grinding 1/4" deep shall be identified and reported to the Bureau of Bridges and Structures for further disposition. The cost of removing welded accessories, grinding and inspecting weld areas and grinding cracks will be paid for according to Article 109.04 of the Standard Specifications.

The existing structural steel coating contains lead. The contractor shall take appropriate precautions to deal with the presence of lead on this project.

Quantities of Deck Slab Repair (Full Depth, Type I), Deck Slab Repair (Full Depth, Type II) and Deck Slab Repair (Partial) are approximated. Locations will be determined by the Resident Engineer following removal of the Concrete Deck Overlay. Actual repair locations shall be shown on the as-built plans. Contractor will be paid for the quantities furnished.

Joint openings shall be adjusted according to article 520.04 of the standard specifications when the deck is poured at an ambient temperature other than 50° F.

DAVID F. MAXWELL  
081-005455  
ST. LOUIS, MO.  
LICENSED STRUCTURAL ENGINEER

*David F. Maxwell*  
David F. Maxwell, S.E.  
Date: 9/10/08  
My registration expires November 30, 2010

**TOTAL BILL OF MATERIAL**

ITEM	UNIT	QUANTITY
Polymerized HMA Surface Course Mix "E", N70	TON	102
Concrete Removal	CU. YD.	16.2
Protective Shield	SQ. YD.	354
Concrete Superstructure	CU. YD.	16.2
Reinforcement Bars, Epoxy Coated	POUND	1850
Bar Splicers	EACH	22
Preformed Joint Strip Seal	FOOT	117
Waterproofing Membrane System	SQ. YD.	570.7
Bridge Deck Scarification	SQ. YD.	564.5
Deck Slab Repair (Full Depth, Type I)	SQ. YD.	32
Deck Slab Repair (Full Depth, Type II)	SQ. YD.	32
Deck Slab Repair (Partial)	SQ. YD.	64
Diamond Grinding (Bridge Section)	SQ. YD.	570.7

**PLAN AND ELEVATION**  
**F.A.I. 74 (OVER 12TH AVE.)**  
**ROCK ISLAND COUNTY**  
**STRUCTURE NO. 081-0101**



STATE OF ILLINOIS  
DEPARTMENT OF TRANSPORTATION

ROUTE NO.	SECTION	COUNTY	TOTAL SHEETS	SHEET NO.	SHEET NO. 2 10 SHEETS
F.A.I. 74	*	ROCK ISLAND	246	149	
FED. ROAD DIST. NO. 7	ILLINOIS	FED. AID PROJECT-			

\* 81 (1-2, 1, 2-2) RS-1 & M

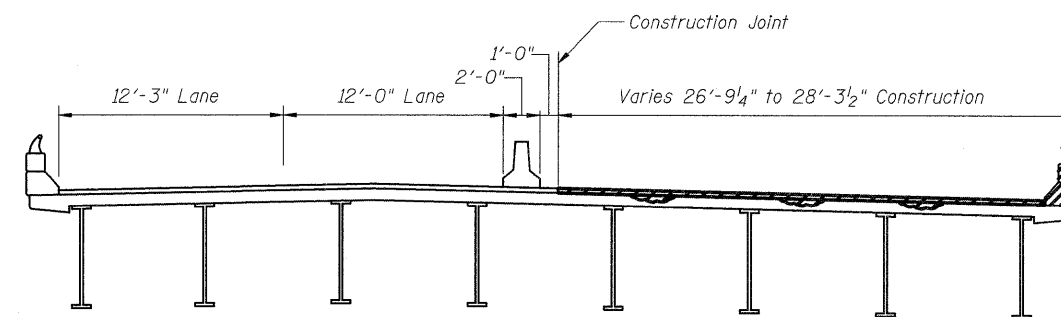
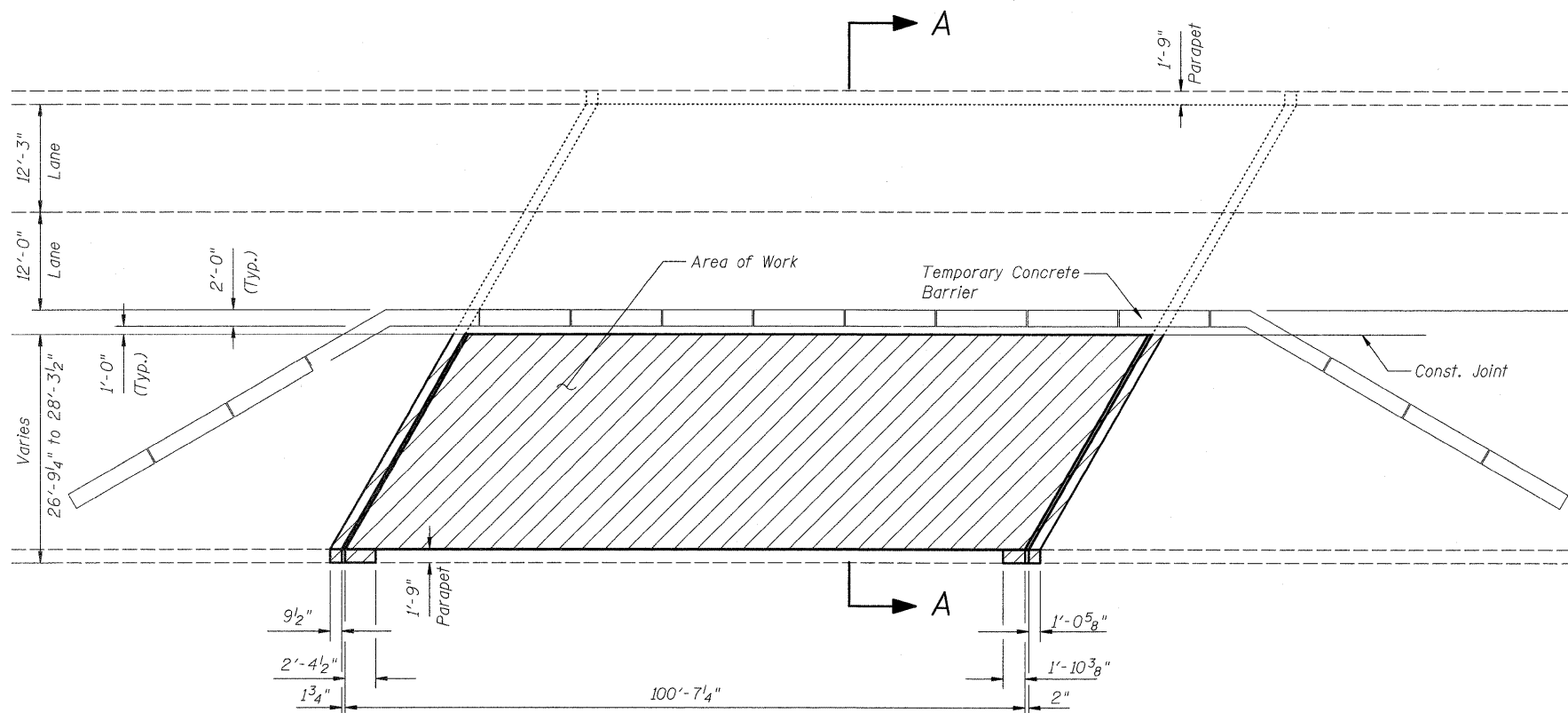

**SECTION A-A**

**STAGE I CONSTRUCTION**

- Install temporary concrete barrier as shown. \*
- Move traffic to Stage I traffic lanes.
- Sawcut concrete wearing surface and remove.
- Replace bridge joints and repair deck.
- Install new wearing surface & waterproofing membrane.

\* For temporary concrete barrier details, see sheet 9 of 10.

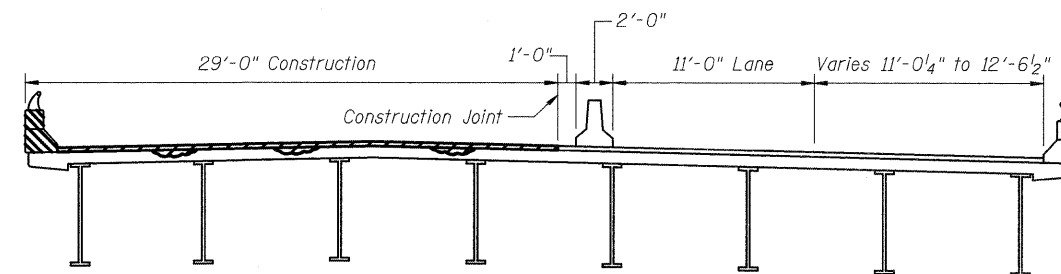
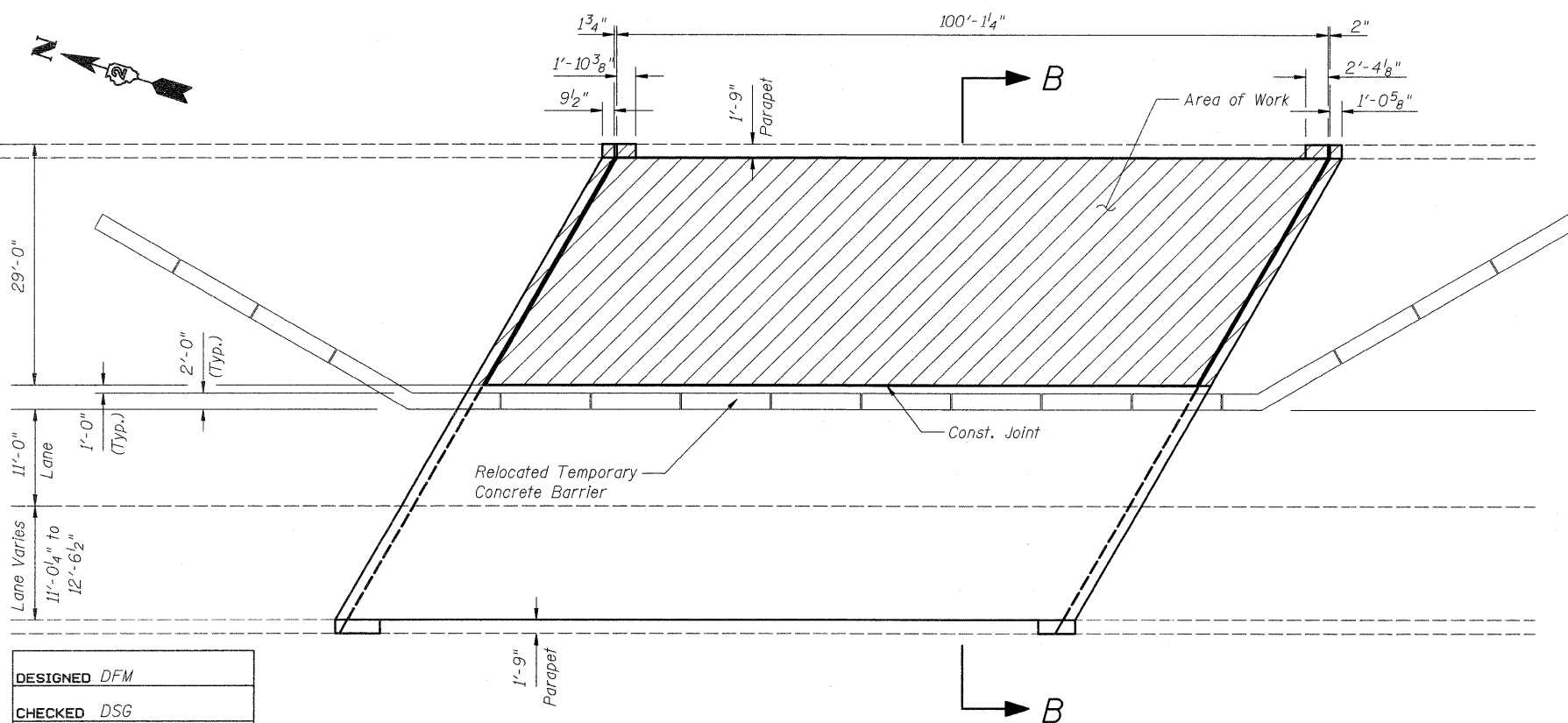

**SECTION B-B**

**STAGE II CONSTRUCTION**

- Relocate temporary concrete barrier as shown. \*
- Move traffic to Stage II traffic lanes.
- Remove concrete wearing surface.
- Replace bridge joints and repair deck.
- Install new wearing surface & waterproofing membrane.
- Remove temporary concrete barrier.

**STAGING PLAN**  
**F.A.I. 74 (OVER 12TH AVE.)**  
**ROCK ISLAND COUNTY**  
**STRUCTURE NO. 081-0101**

DESIGNED	DFM
CHECKED	DSG
DRAWN	EBS
CHECKED	DFM

STATE OF ILLINOIS  
DEPARTMENT OF TRANSPORTATION

ROUTE NO.	SECTION	COUNTY	TOTAL SHEETS	SHEET NO.	SHEET NO. 3 10 SHEETS
FAI 74	#	ROCK ISLAND	246	150	
FED. ROAD DIST. NO. 7		ILLINOIS	FED. AID PROJECT-		

\* 81 (1-2, 1, 2-2) RS-1 & M

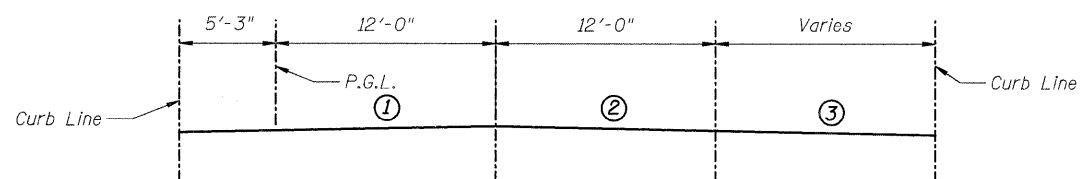

CURRENT STATION	ORIGINAL STATION	SLOPE ①	SLOPE ②	SLOPE ③
72+65.90	299+50	0.032	0.015	-0.0156
73+15.90	300+00	0.0225	0.00	-0.017
73+65.90	300+50	0.017	-0.010	-0.019
73+90.90	300+75	0.0163	-0.013	-0.0196

**BILL OF MATERIAL**

ITEM	UNIT	QUANTITY
Polymerized HMA Surface Course Mix "E", N90	TON	102
Protective Shield	SQ. YD.	354
Waterproofing Membrane System	SQ. YD.	570.7
Bridge Deck Scarification	SQ. YD.	564.5
Diamond Grinding (Bridge Section)	SQ. YD.	570.7

**EXISTING SLOPE CONFIGURATION**

(Looking South)

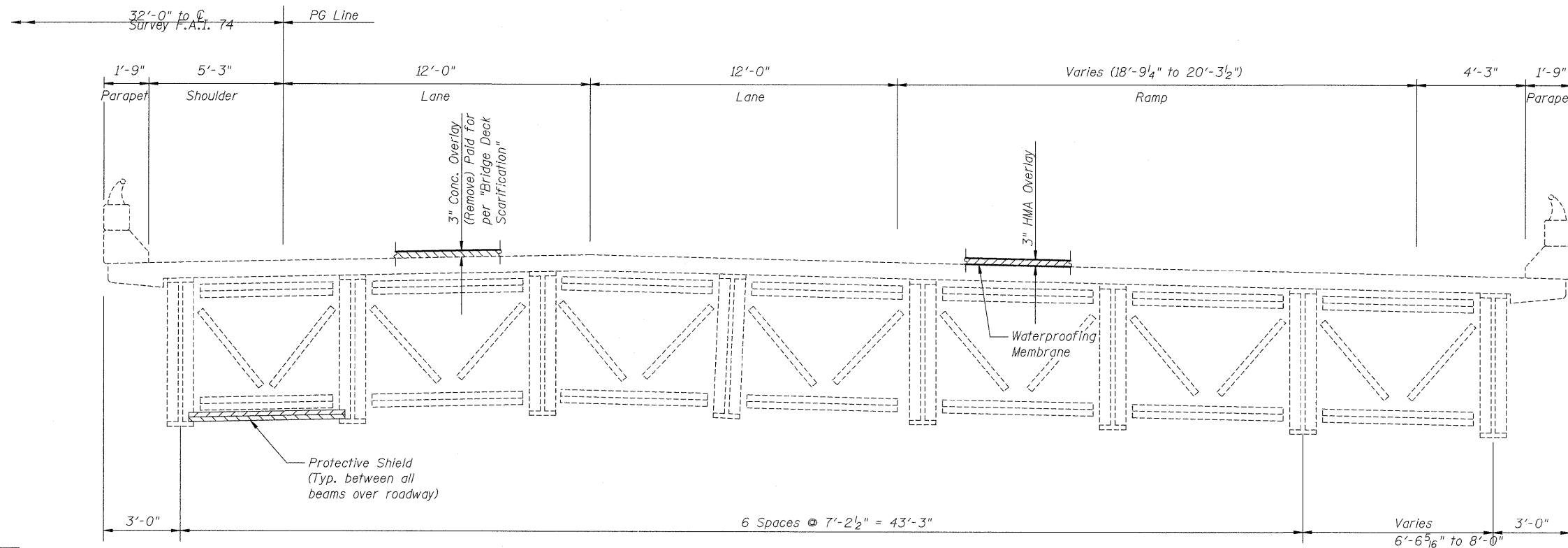

**CROSS SECTION**

(Looking South)

DESIGNED	DFM
CHECKED	DSG
DRAWN	EBS
CHECKED	DFM

**BRIDGE REPAIR DETAILS**  
**F.A.I. 74 (OVER 12TH AVE.)**  
**ROCK ISLAND COUNTY**  
**STRUCTURE NO. 081-0101**

STATE OF ILLINOIS  
DEPARTMENT OF TRANSPORTATION

ROUTE NO. FAT 74	SECTION *	COUNTY ROCK ISLAND	TOTAL SHEETS 246	SHEET NO. 151	SHEET NO. 4 10 SHEETS
FED. ROAD DIST. NO. 7		ILLINOIS FED. AID PROJECT-			

\* 81 (1-2, 1, 2-2) RS-1 & M

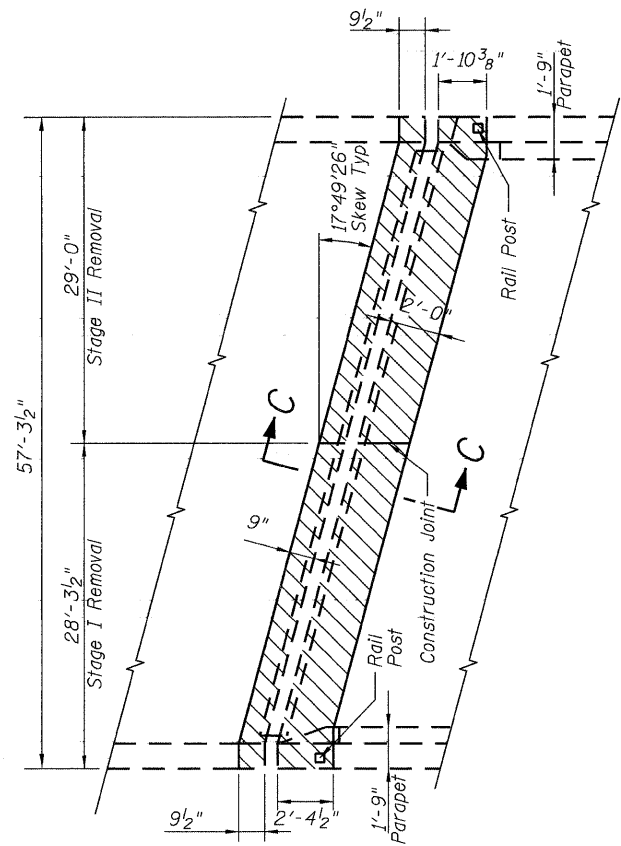

EXISTING PARTIAL PLAN - NORTH ABUTMENT

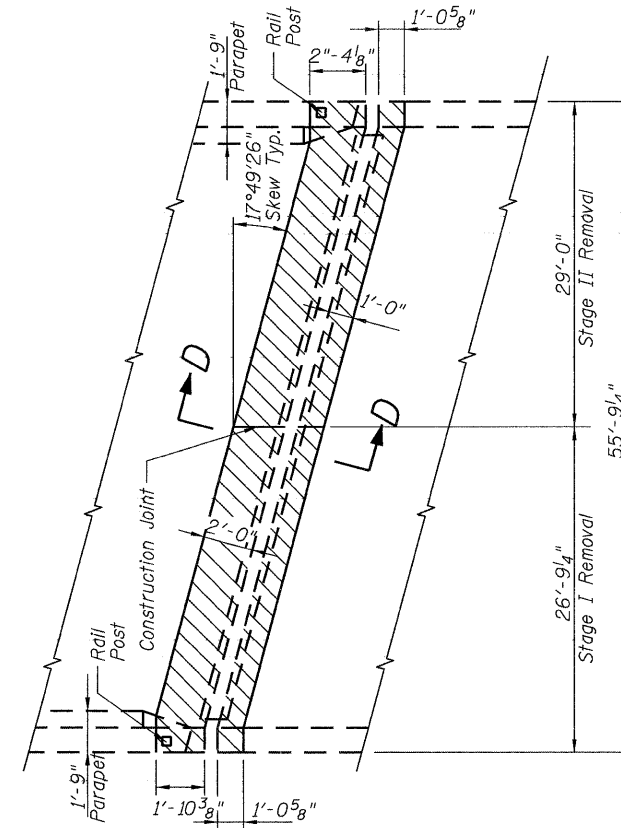

EXISTING PARTIAL PLAN - SOUTH ABUTMENT

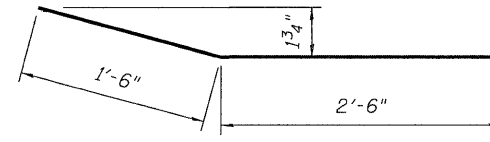

BAR a (E)

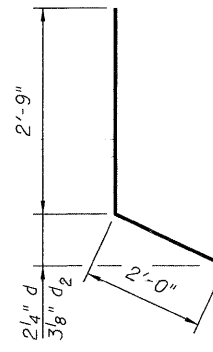

BAR d (E) & d2 (E)

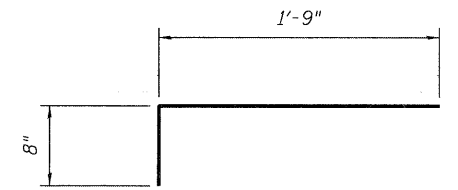

BAR s (E)

BILL OF MATERIAL

BAR	NO.	SIZE	LENGTH	SHAPE
a (E)	10	#6	4'-0"	
a <sub>1</sub> (E)	8	#5	28'-1"	
a <sub>2</sub> (E)	8	#5	29'-3"	
a <sub>3</sub> (E)	3	#6	28'-2"	
a <sub>4</sub> (E)	3	#6	29'-3"	
a <sub>5</sub> (E)	8	#5	26'-6"	
a <sub>6</sub> (E)	8	#5	29'-3"	
a <sub>7</sub> (E)	3	#6	26'-6"	
a <sub>8</sub> (E)	3	#6	29'-3"	
d	5	#4	4'-9"	
d <sub>1</sub>	10	#5	2'-9"	
d <sub>2</sub>	5	#4	4'-9"	
d <sub>3</sub>	8	#4	2'-1"	
s (E)	107	#5	2'-5"	
Reinforcement Bars Epoxy Coated			Pound	1850
Concrete Removal			Cu. Yd.	16.2
Concrete Superstructure			Cu. Yd.	16.2
Bar Splicer			Each	22

For bar splicer assembly details see sheet 8 of 10.  
For Sections C-C & D-D, see sheet 5 of 10.  
For rail post details, see sheet 10 of 10.

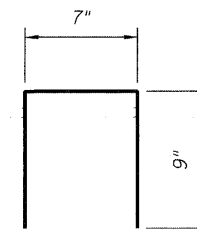

BAR d<sub>3</sub> (E)

LEGEND

- Concrete Removal
- Concrete Superstructure

JOINT RECONSTRUCTION DETAILS  
F.A.I. 74 (OVER 12TH AVE.)  
ROCK ISLAND COUNTY  
STRUCTURE NO. 081-0101

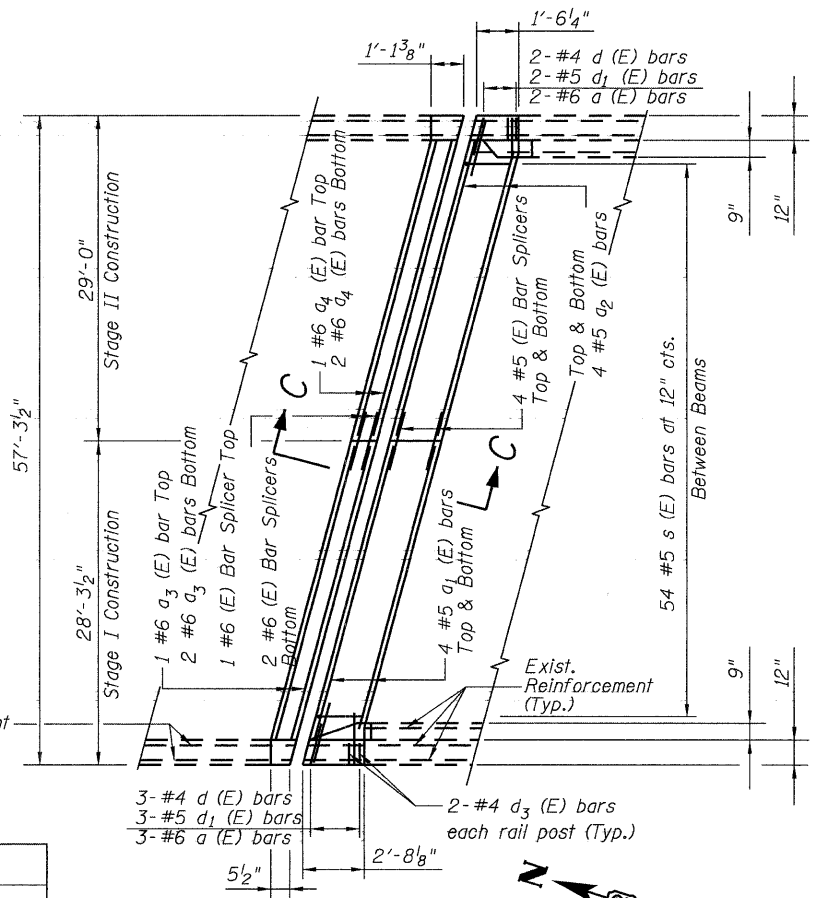

PROPOSED PARTIAL PLAN - NORTH ABUTMENT

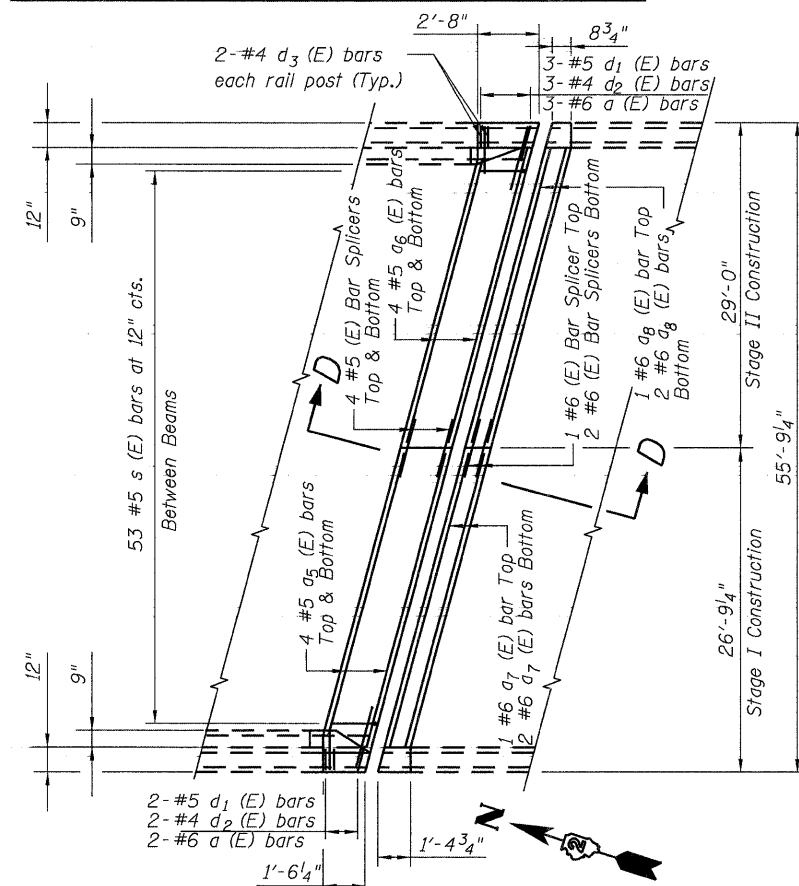

PROPOSED PARTIAL PLAN - SOUTH ABUTMENT

DESIGNED	DFM
CHECKED	DSG
DRAWN	EBS
CHECKED	DFM

STATE OF ILLINOIS  
DEPARTMENT OF TRANSPORTATION

ROUTE NO.	SECTION	COUNTY	TOTAL SHEETS	SHEET NO.	SHEET NO. 5 10 SHEETS
FAI 74	*	ROCK ISLAND	246	152	
FED. ROAD DIST. NO. 7		ILLINOIS	FED. AID PROJECT-		

\* 81 (1-2, 1, 2-2) RS-1 & M

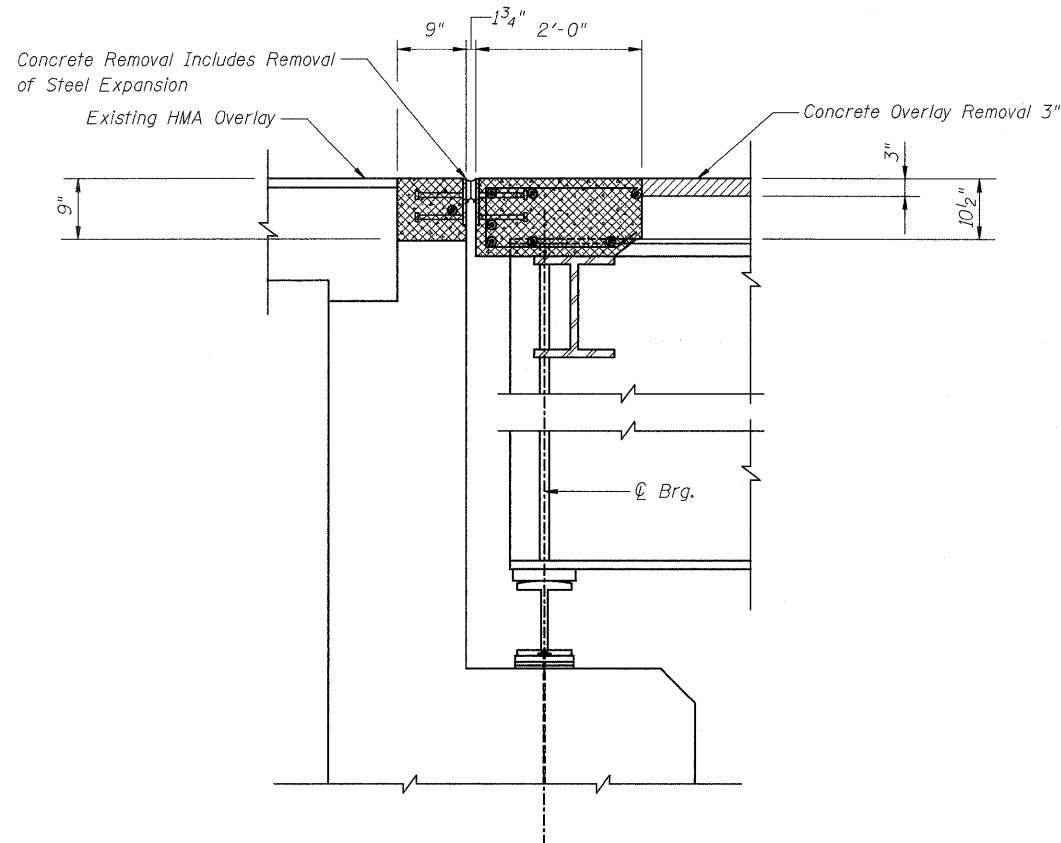

EXISTING SECTION C-C THRU NORTH ABUTMENT

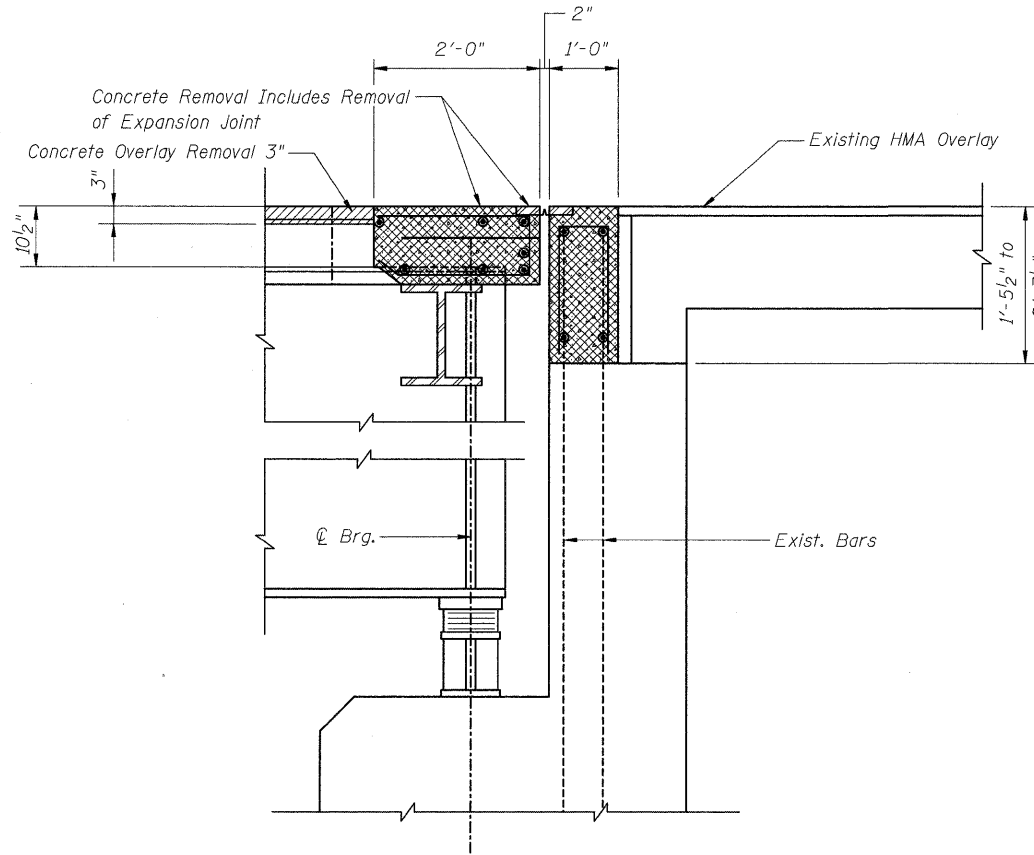

EXISTING SECTION D-D THRU SOUTH ABUTMENT

LEGEND

- Concrete Removal
- Bridge Deck Scarification

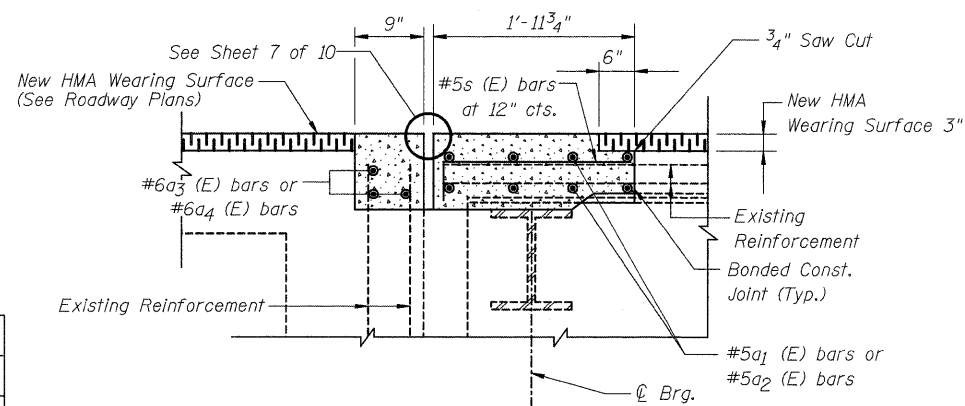

PROPOSED SECTION C-C THRU NORTH ABUTMENT

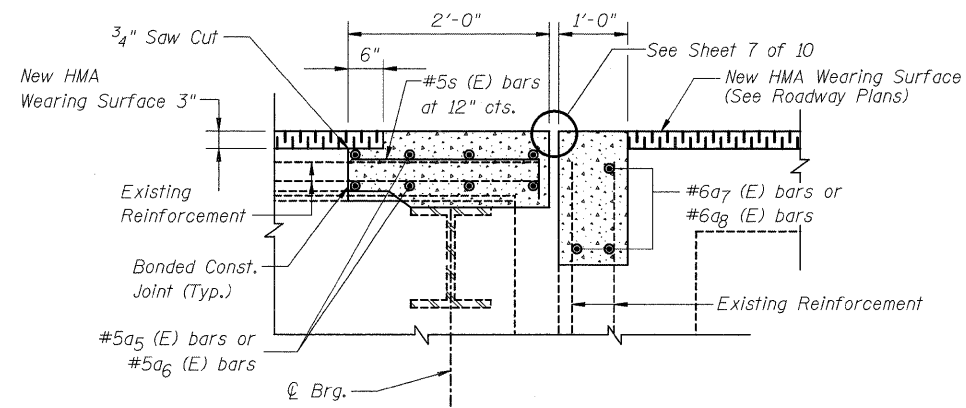

PROPOSED SECTION D-D THRU SOUTH ABUTMENT

DESIGNED	DFM
CHECKED	DSG
DRAWN	EBS
CHECKED	DFM

**JOINT RECONSTRUCTION DETAILS**  
**F.A.I. 74 (OVER 12TH AVE.)**  
**ROCK ISLAND COUNTY**  
**STRUCTURE NO. 081-0101**

STATE OF ILLINOIS  
DEPARTMENT OF TRANSPORTATION

ROUTE NO.	SECTION	COUNTY	TOTAL SHEETS	SHEET NO.	SHEET NO.
FAI 74	*	ROCK ISLAND	246	153	10 SHEETS
FED. ROAD DIST. NO. 7		ILLINOIS		FED. AID PROJECT	

\* 81 (1-2, 1, 2-2) RS-1 & M

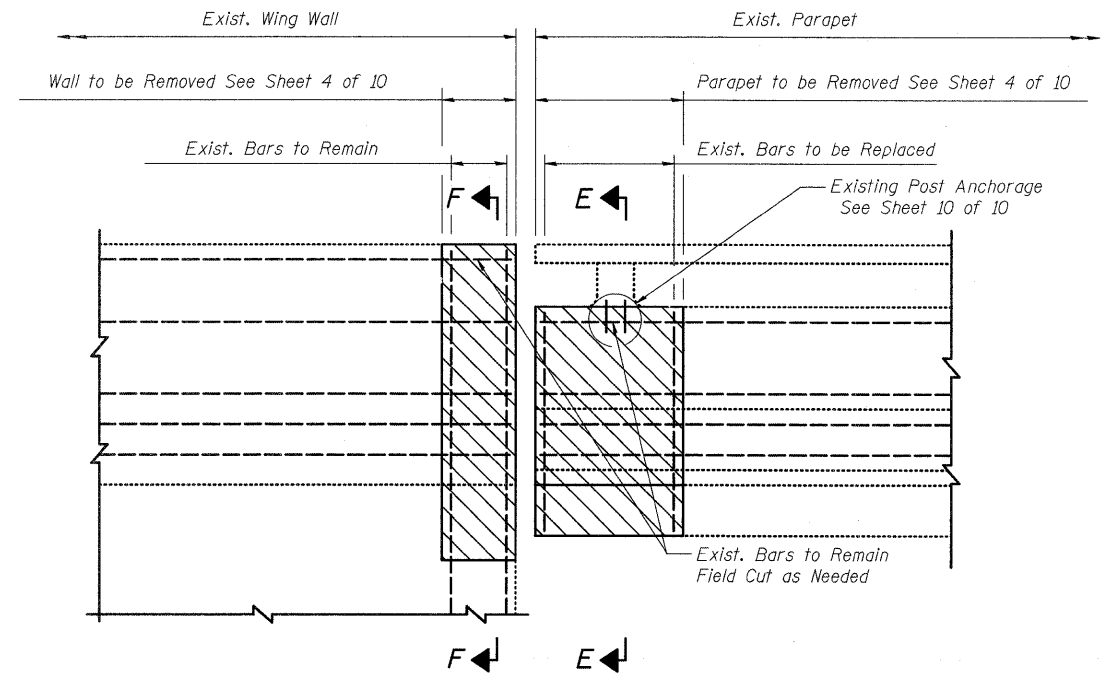

ELEVATION OF CONCRETE REMOVAL THRU PARAPET AND WING WALL

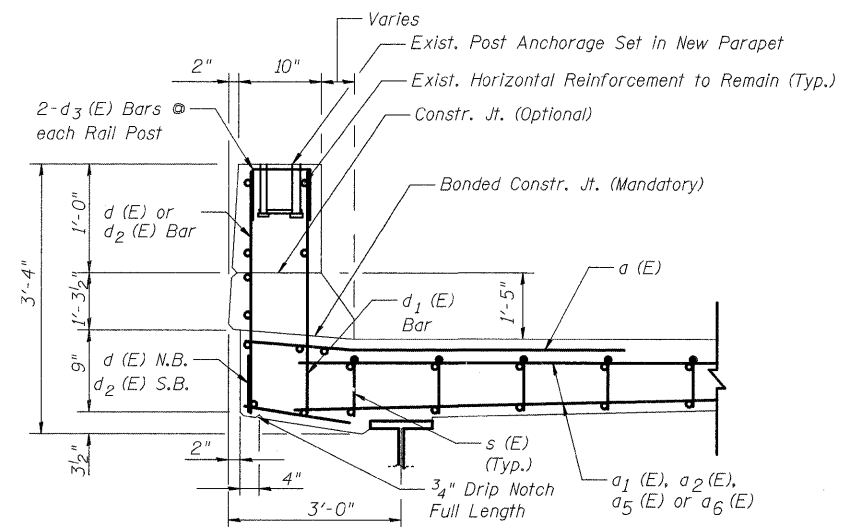

SECTION E-E THRU BRIDGE DECK PARAPET

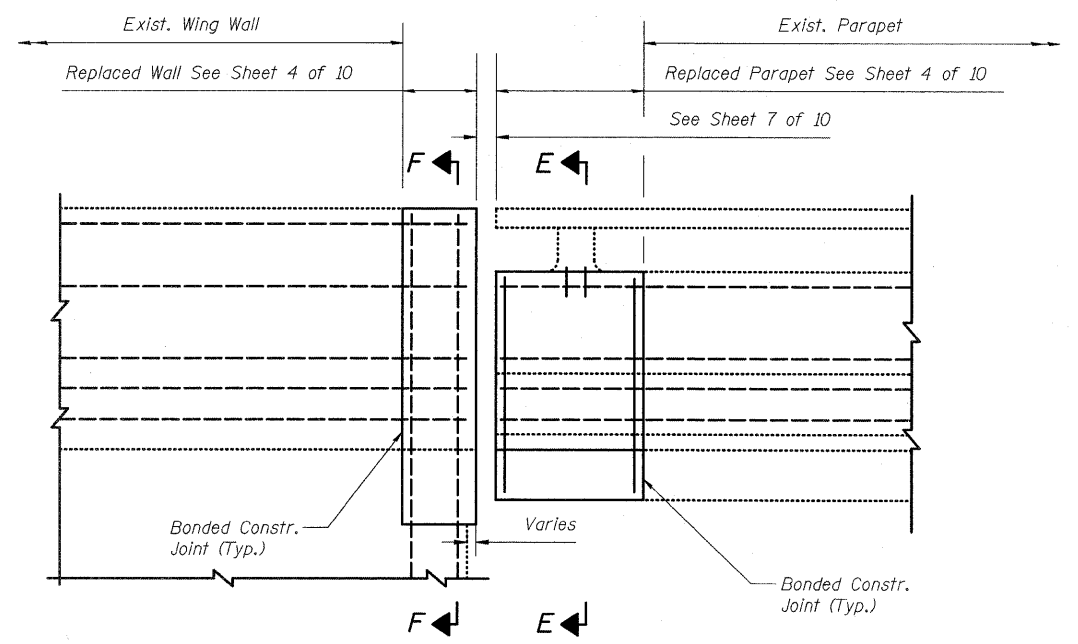

ELEVATION OF CONCRETE REPLACEMENT THRU PARAPET AND WING WALL

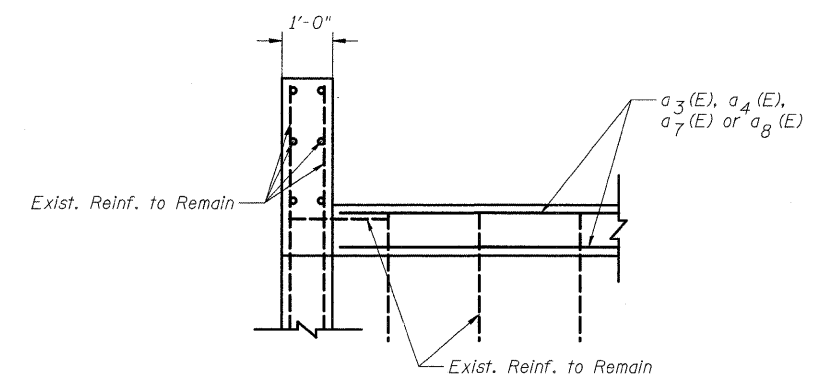

SECTION F-F THRU ABUTMENT BACKWALL AND WING WALL

DESIGNED	DFM
CHECKED	DSG
DRAWN	EBS
CHECKED	DFM

Hatched areas indicate concrete sections to be removed and replaced. Perimeters of concrete removal areas shall be saw cut 3/4" prior to the removal of concrete.

PARAPET AND RETAINING WALL DETAILS  
F.A.I. 74 (OVER 12TH AVE.)  
ROCK ISLAND COUNTY  
STRUCTURE NO. 081-0101

STATE OF ILLINOIS  
DEPARTMENT OF TRANSPORTATION

ROUTE NO.	SECTION	COUNTY	TOTAL SHEETS	SHEET NO.	SHEET NO. 7
FAI 74	*	ROCK ISLAND	246	154	10 SHEETS
FED. ROAD DIST. NO. 7	ILLINOIS	FED. AID PROJECT-			

\*Granular or solid flux filled headed studs conforming to Article 1006.32 of the Std. Specs., automatically end welded.

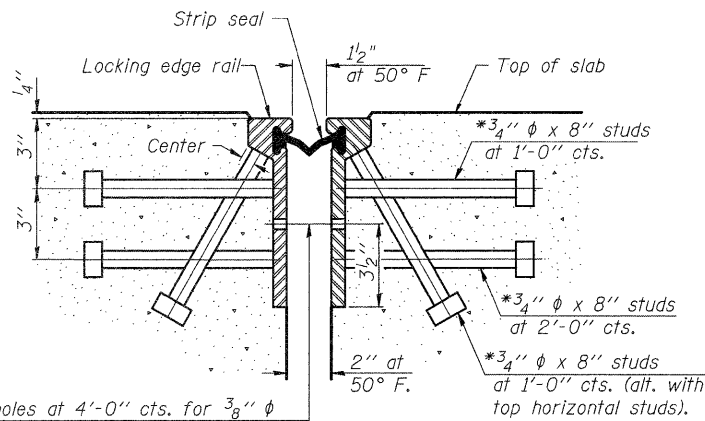

7/16"  $\phi$  holes at 4'-0" cts. for 3/8"  $\phi$  bolts. All bolts shall be burned, sawed, or chipped off flush with the plates after forms are removed, typ.

SECTION THRU ROLLED RAIL JOINT

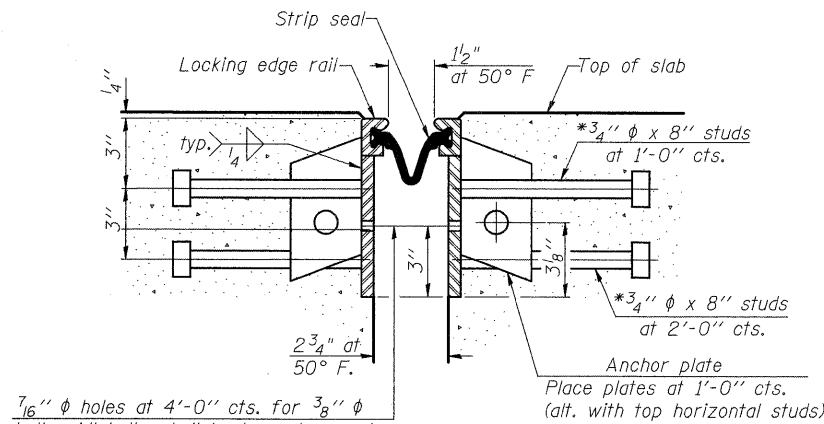

7/16"  $\phi$  holes at 4'-0" cts. for 3/8"  $\phi$  bolts. All bolts shall be burned, sawed, or chipped off flush with the plates after forms are removed, typ.

SECTION THRU WELDED RAIL JOINT

Notes:

The strip seal shall be made continuous and shall have a minimum thickness of 1/4". The configuration of the strip seal shall match the configuration of the Locking Edge Rails. Open or "webbed" strip seal gland configurations are not permitted. The gland shall be sized for a maximum rated movement of 4 inches.

The height and thickness of the Locking Edge Rails shown are minimum dimensions. The actual configuration of the Locking Edge Rails and matching strip seal may vary from manufacturer to manufacturer. Flanged edge rails will not be allowed. Locking Edge Rails may be spliced at slope discontinuities and stage construction joints.

The manufacturer's recommended installation methods shall be followed.

The joint opening and deck dimensions detailed on the superstructure are based on a rolled rail expansion joint. If the Contractor elects to use the welded rail expansion joint, the opening and deck dimensions shall be modified according to the dimensions detailed on this sheet. Required modifications shall be made at no additional cost to the State.

All steel components shall be galvanized after fabrication according to Article 520.03 of the Standard Specifications.

\* 81 (1-2, 1, 2-2) RS-1 & M

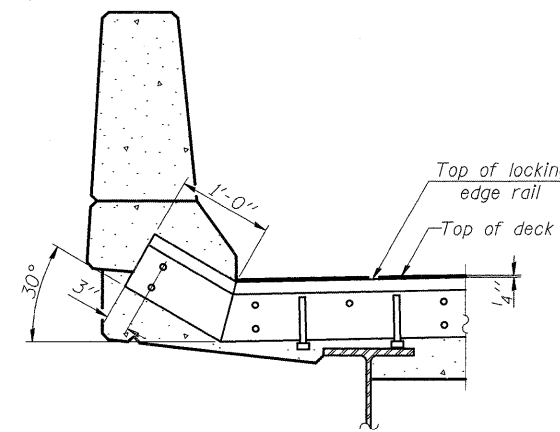

AT PARAPET

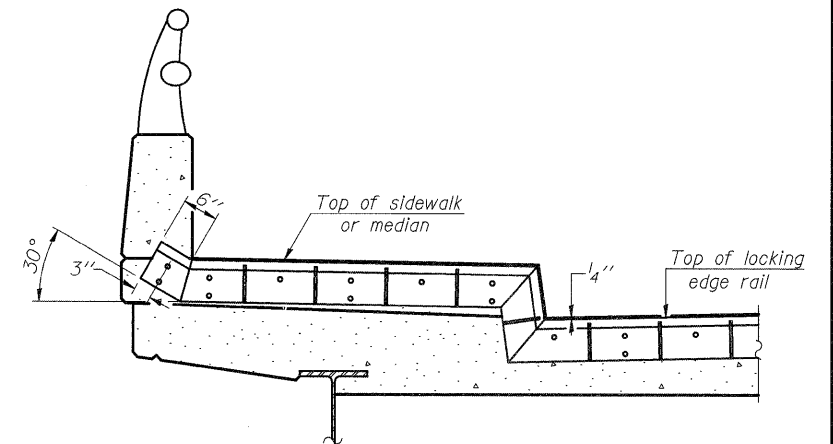

AT SIDEWALK OR MEDIAN

Shorter plates with a single row of studs at 12" cts. may be necessary on medians which are shallower than 9'. See manufacturer's recommendation.

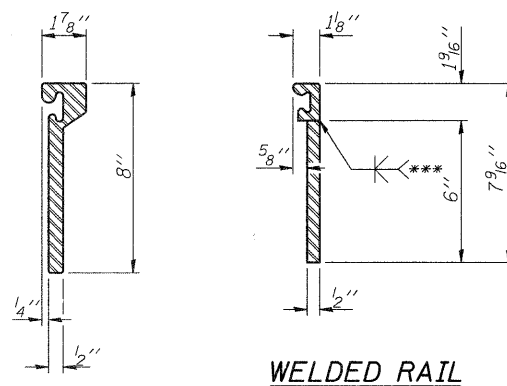

ROLLED EXTRUDED RAIL

WELDED RAIL

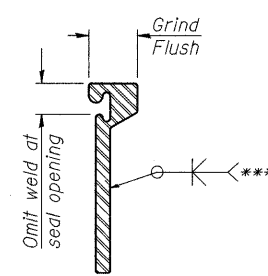

\*\*\*Back gouge not required if complete joint penetration is verified by mock-up.

LOCKING EDGE RAIL SPLICE

The inside of the locking edge rail groove shall be free of weld residue.

LOCKING EDGE RAILS

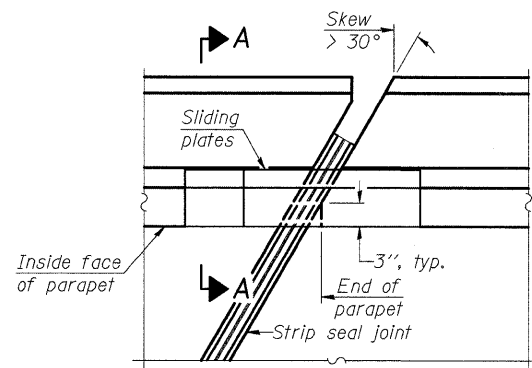

PLAN

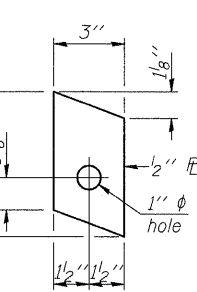

ANCHOR PLATE  
(for welded rail)

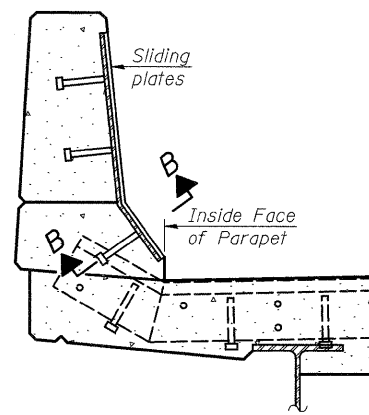

SECTION A-A

POINT BLOCK DETAILS  
(for skews > 30°)

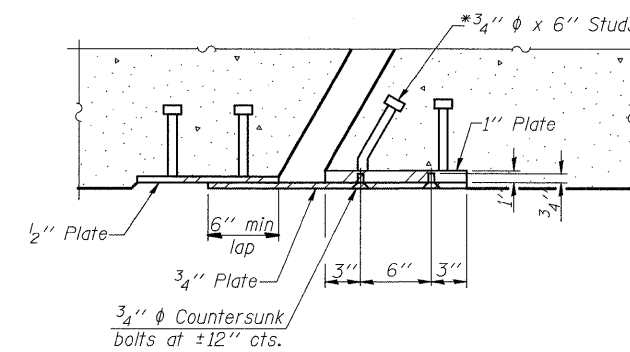

SECTION B-B

TYPICAL END TREATMENTS

BILL OF MATERIAL

Item	Unit	Total
Preformed Joint Strip Seal	Foot	117

DESIGNED	DFM
CHECKED	DSG
DRAWN	EBS
CHECKED	DFM

EJ-SSJ

5-16-08

PREFORMED JOINT STRIP SEAL  
F.A.I. 74 (OVER 12TH AVE.)  
ROCK ISLAND COUNTY  
STRUCTURE NO. 081-0101

\* 81 (1-2, 1, 2-2) RS-1 & M

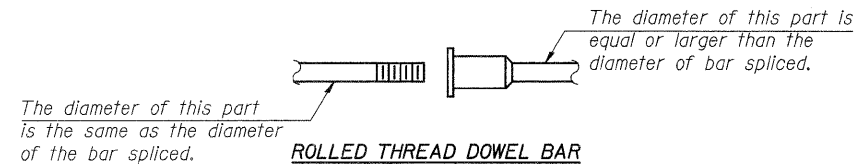

Wire Connector

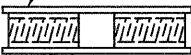

**BAR SPLICER ASSEMBLY ALTERNATIVES**

\*\*Heavy Hex Nuts conforming to ASTM A 563, Grade C, D or DH may be used.

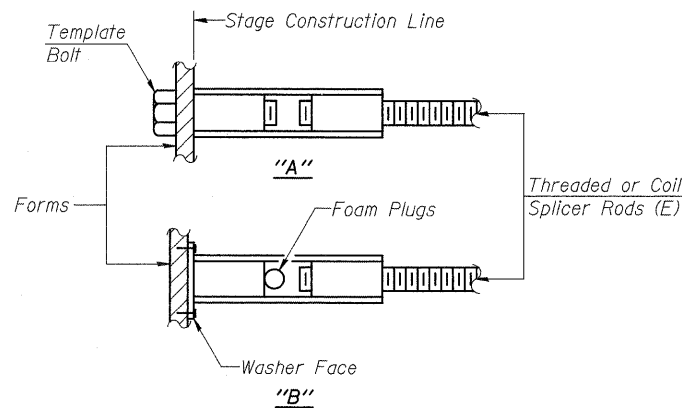

**INSTALLATION AND SETTING METHODS**

"A" :Set bar splicer assembly by means of a template bolt.  
"B" :Set bar splicer assembly by nailing to wood forms or cementing to steel forms.  
(E) : Indicates epoxy coating.

**NOTES**

Bar splicer assemblies shall be of an approved type and shall develop in tension at least 125 percent of the yield strength of the lapped reinforcement bars.  
Splicer rods shall be of minimum 60 ksi yield strength, threaded or coiled full length.  
All reinforcement bars shall be lapped and tied to the splicer rods or dowel bars.  
Bar splicer assemblies shall be epoxy coated according to the requirements for reinforcement bars.  
Other systems of similar design may be submitted to the Engineer for approval. Approval shall be based on certified test results from an approved testing laboratory that the proposed bar splicer assembly satisfies the following requirements:

- Minimum Capacity =  $1.25 \times f_y \times A_t$   
(Tension in kips)
  - Minimum \*Pull-out Strength =  $0.66 \times f_y \times A_t$   
(Tension in kips)
- Where  $f_y$  = Yield strength of lapped reinforcement bars in ksi.  
 $A_t$  = Tensile stress area of lapped reinforcement bars.  
\* = 28 day concrete

BAR SPLICER ASSEMBLIES			
Bar Size to be Spliced	Splicer Rod or Dowel Bar Length	Strength Requirements	
		Min. Capacity kips - tension	Min. Pull-Out Strength kips - tension
#4	1'-8"	14.7	7.9
#5	2'-0"	23.0	12.3
#6	2'-7"	33.1	17.4
#7	3'-5"	45.1	23.8
#8	4'-6"	58.9	31.3
#9	5'-9"	75.0	39.6
#10	7'-3"	95.0	50.3
#11	9'-0"	117.4	61.8

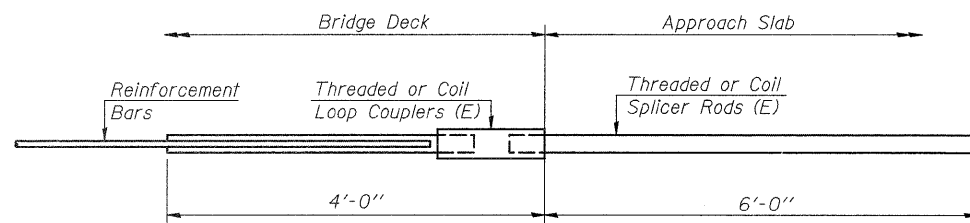

**FOR INTEGRAL OR SEMI-INTEGRAL ABUTMENTS**

Bar Splicer for #5 bar
Min. Capacity = 23.0 kips - tension
Min. Pull-out Strength = 12.3 kips - tension
No. Required =

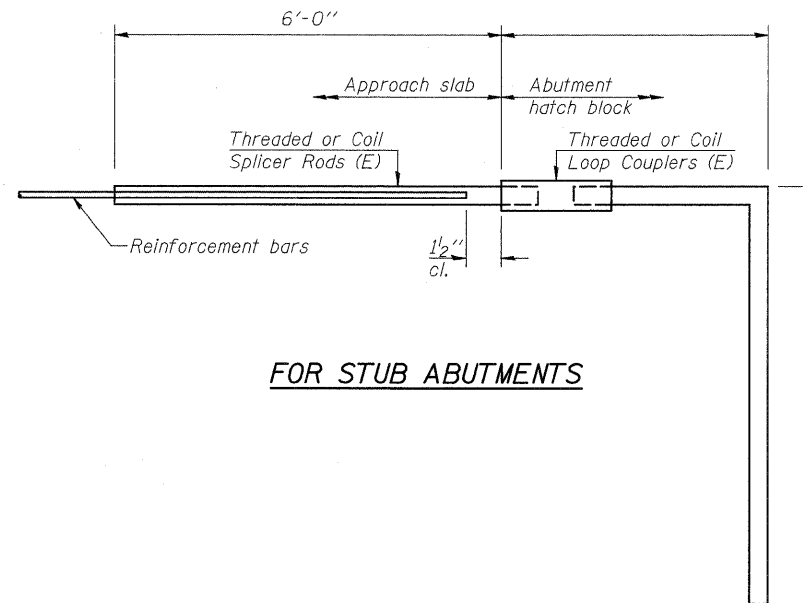

**FOR STUB ABUTMENTS**

Bar Splicer for #5 bar
Min. Capacity = 23.0 kips - tension
Min. Pull-out Strength = 12.3 kips - tension
No. Required =

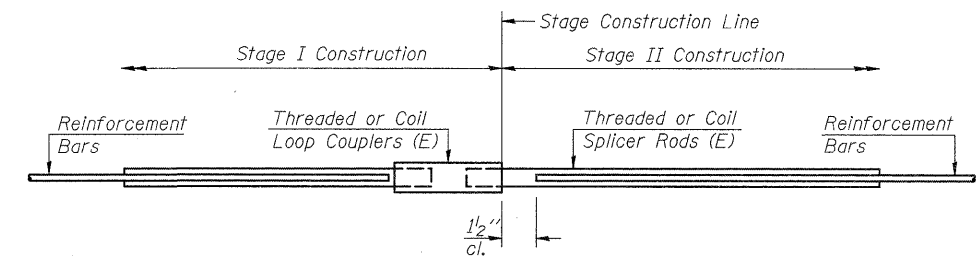

**STANDARD**

Bar Size	No. Assemblies Required	Location
#5	8	Bridge Deck at South Abutment
#5	8	Bridge Deck at North Abutment
#6	3	South Abutment Backwall
#6	3	North Abutment Backwall

**BAR SPLICER ASSEMBLY DETAILS**  
F.A.I. 74 (OVER 12TH AVE.)  
ROCK ISLAND COUNTY  
STRUCTURE NO. 081-0101

DESIGNED DFM
CHECKED DSG
DRAWN EBS
CHECKED DFM

BSD-1

5-16-08

STATE OF ILLINOIS  
DEPARTMENT OF TRANSPORTATION

ROUTE NO.	SECTION	COUNTY	TOTAL SHEETS	SHEET NO.	SHEET NO. 9
FAI 74	*	ROCK ISLAND	246	156	10 SHEETS
FED. ROAD DIST. NO. 7	ILLINOIS	FED. AID PROJECT-			

\* 81 (1-2, 1, 2-2) RS-1 & M

When "A" is 3'-6" or less, the temporary concrete barrier shall be anchored to the new slab according to Detail I or Detail II. No anchorage is required when "A" is greater than 3'-6".

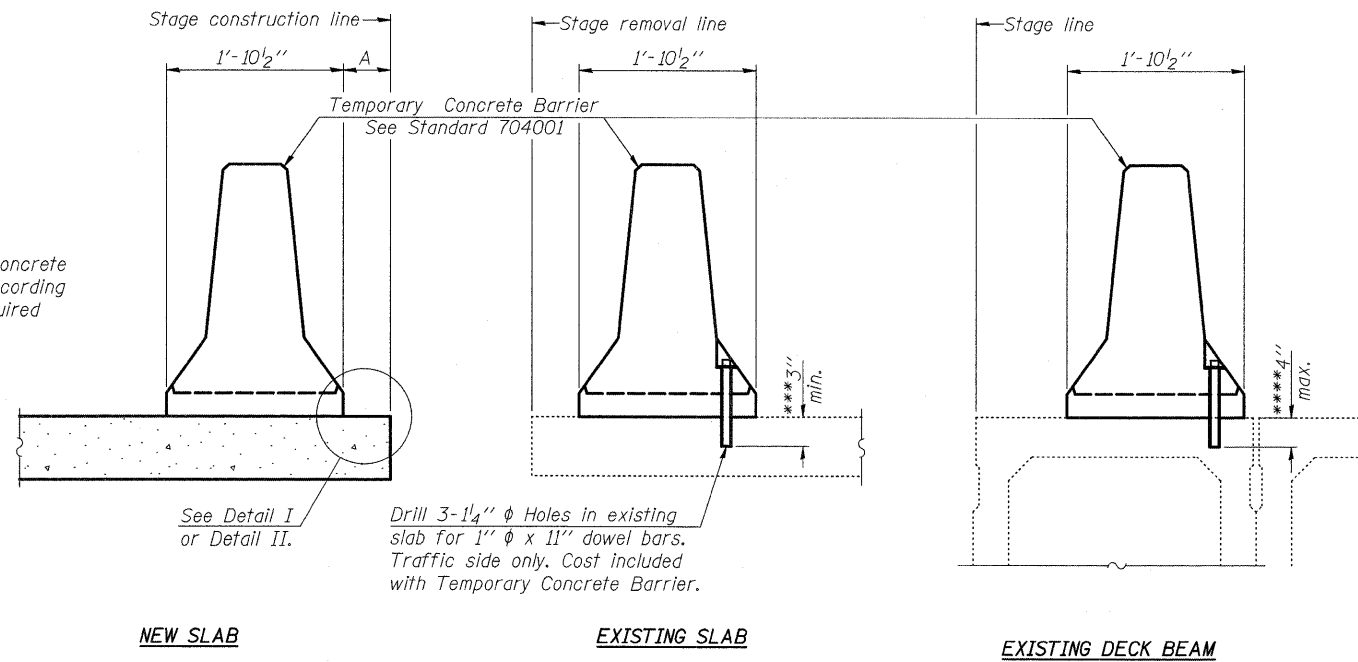

Drill 3-1 1/4"  $\phi$  Holes in existing slab for 1"  $\phi$  x 11" dowel bars. Traffic side only. Cost included with Temporary Concrete Barrier.

**NOTES**

**Detail I - With Bar Splicer or Couplers:**  
Connect one (1) 1"x7"x10" steel  $\bar{P}$  to the top layer of couplers with 2-5/8"  $\phi$  bolts screwed to coupler at approximate  $\bar{C}$  of each barrier panel.

**Detail II - With Extended Reinforcement Bars:**  
Connect one (1) 1"x7"x10" steel  $\bar{P}$  to the concrete slab or concrete wearing surface with 2-5/8"  $\phi$  Expansion Anchors or cast in place inserts spaced between the top layer of reinforcement at approximate  $\bar{C}$  of each barrier panel.

Cost of anchorage is included with Temporary Concrete Barrier. The 1" x 7" x 10" plate shall not be removed until stage II construction forms and all reinforcement bars are in place and the concrete is ready to be placed.

**SECTIONS THRU SLAB OR DECK BEAM**

\*\*\*Dimension shown is minimum required embedment into concrete. If hot-mix asphalt wearing surface is present, minimum embedment shall be in addition to wearing surface depth.

\*\*\*\*If existing deck beam is to remain in place after stage construction, embedment shall only be into wearing surface and not into existing deck beam concrete.

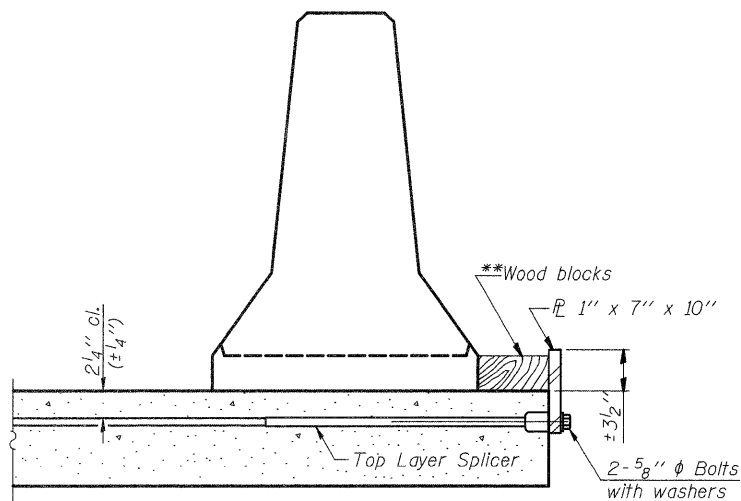

**DETAIL I**

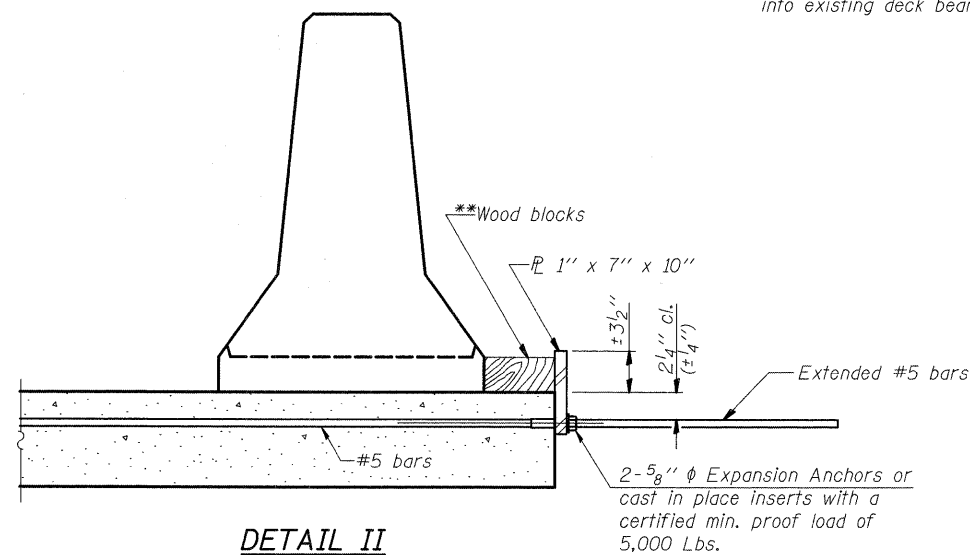

**DETAIL II**

\*\*Wood blocks may be omitted when required to provide minimum stage traffic lane width. When the wood blocks are omitted, the concrete barrier shall be in direct contact with the steel retainer plate.

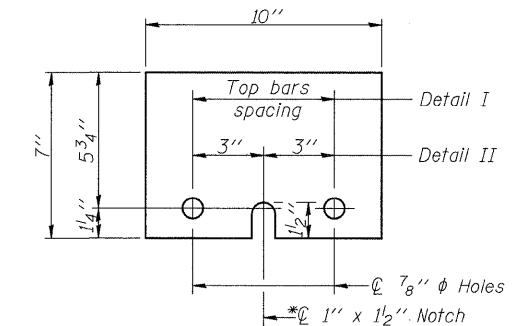

**STEEL RETAINER 1" x 7" x 10"**

\*Required only with Detail II

**TEMPORARY CONCRETE BARRIER  
FOR STAGE CONSTRUCTION  
F.A.I. 74 (OVER 12TH AVE.)  
ROCK ISLAND COUNTY  
STRUCTURE NO. 081-0101**

DESIGNED	DFM
CHECKED	DSG
DRAWN	EBS
CHECKED	DFM



STATE OF ILLINOIS  
DEPARTMENT OF TRANSPORTATION

ROUTE NO.	SECTION	COUNTY	TOTAL SHEETS	SHEET NO.	SHEET NO. 10
FAI 74	#	ROCK ISLAND	246	157	10 SHEETS
FED. ROAD DIST. NO. 7	ILLINOIS	FED. AID PROJECT-			

\* B1 (1-2, 1, 2-2) RS-1 & M

**NOTE:**  
Seal perimeter of post to parapet with two component non-staining gray sealing compound with polysulfide liquid polymers-gun grade with primer.

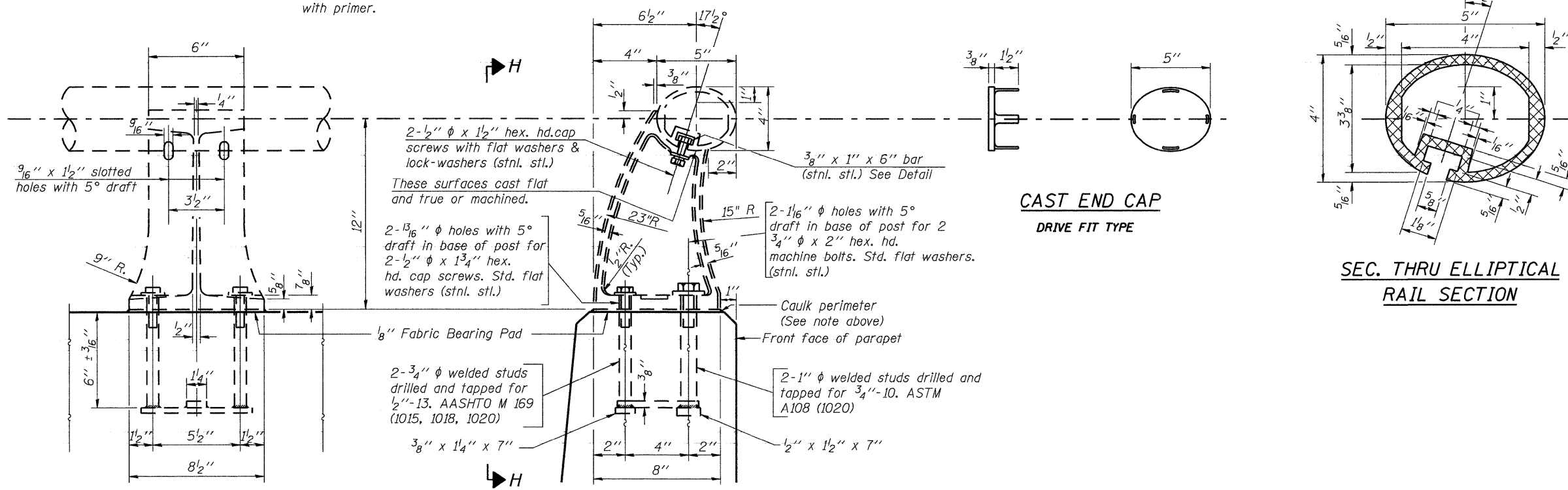

VIEW H-H

SECTION G-G

RAIL POST DETAILS

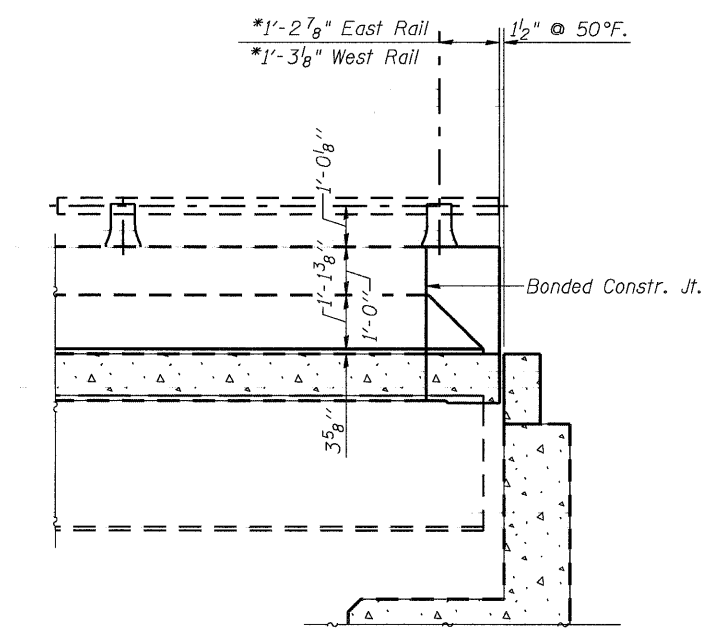
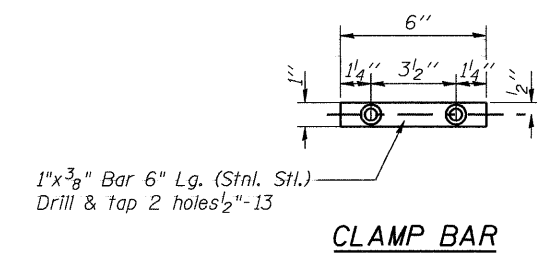

INSIDE VIEW AT PROPOSED ABUTMENTS

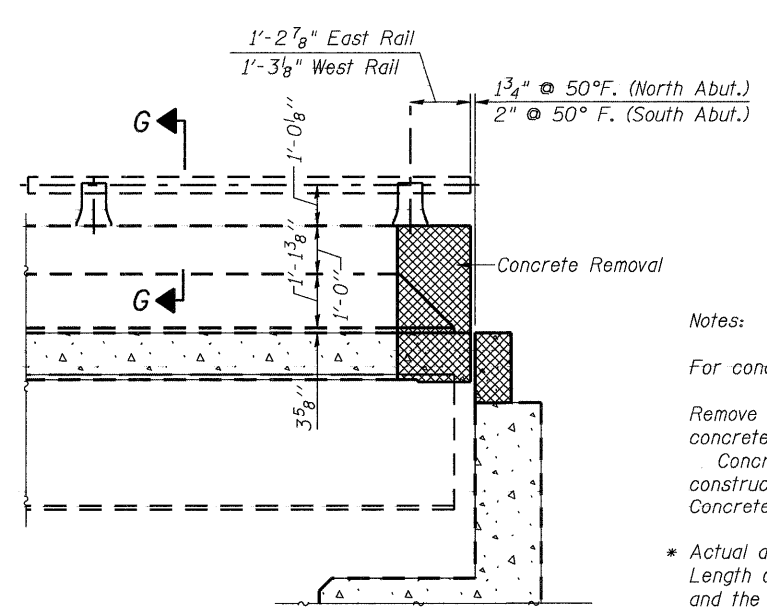

INSIDE VIEW AT EXISTING ABUTMENTS

**Notes:**  
For concrete removal limits See Sheet 4 of 10.  
Remove and reuse railing, including posts and anchors, where concrete removal affects existing rail posts. Cost included with Concrete Superstructure. If anchors are damaged during construction, they shall be replaced and are included with Concrete Removal.  
\* Actual distance varies. New Joints are skewed through Parapet. Length of rail shall be adjusted as necessary with a flush cut and the cast end cap shall be reused.

DESIGNED	DFM
CHECKED	DSG
DRAWN	EBS
CHECKED	DFM

RAILING DETAILS  
F.A.I. 74 (OVER 12TH AVE.)  
ROCK ISLAND COUNTY  
STRUCTURE NO. 081-0101

STATE OF ILLINOIS  
DEPARTMENT OF TRANSPORTATION

ROUTE NO.	SECTION	COUNTY	TOTAL SHEETS	SHEET NO.	SHEET NO. 1
FAI 74	*	ROCK ISLAND	246	158	10 SHEETS
FED. ROAD DIST. NO. 7		ILLINOIS	FED. AID PROJECT-		

\* 81 (1-2, 1, 2-2) RS-1 & M

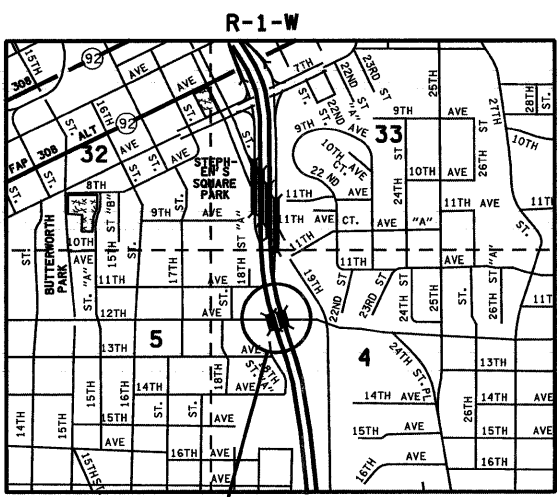
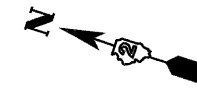
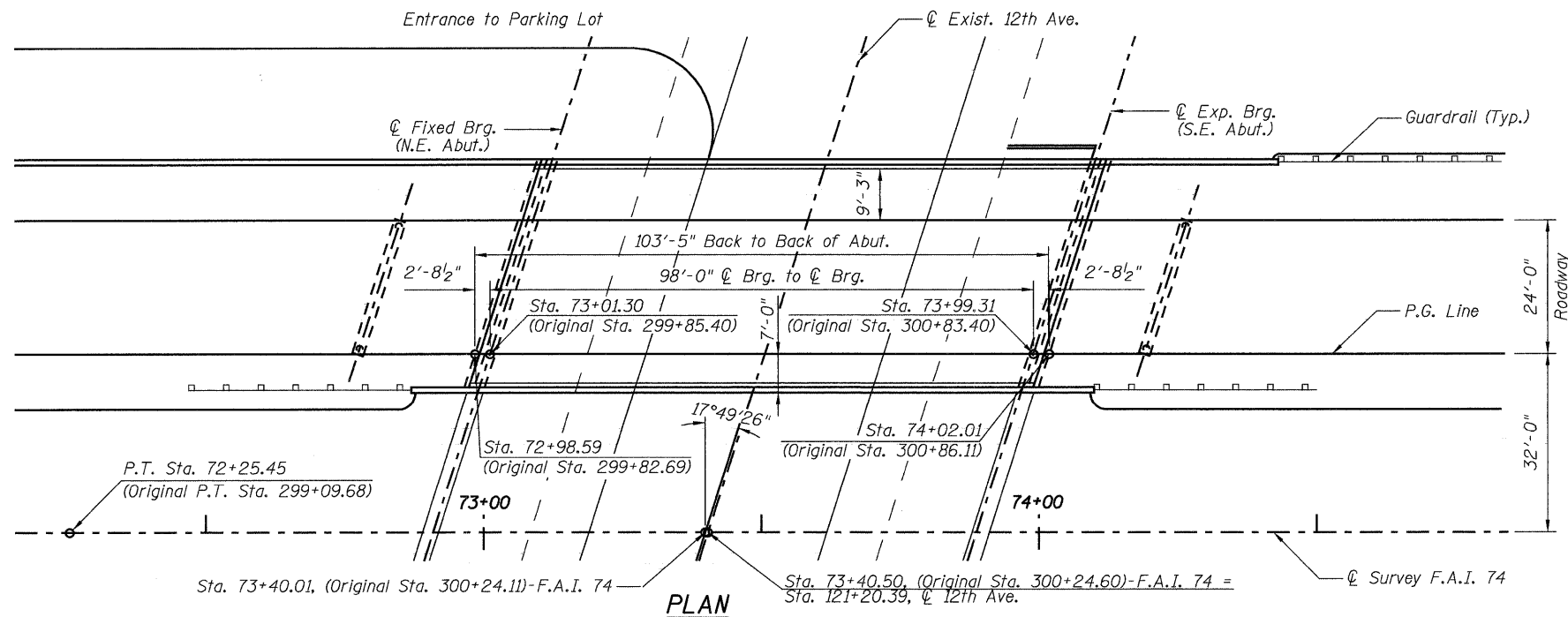
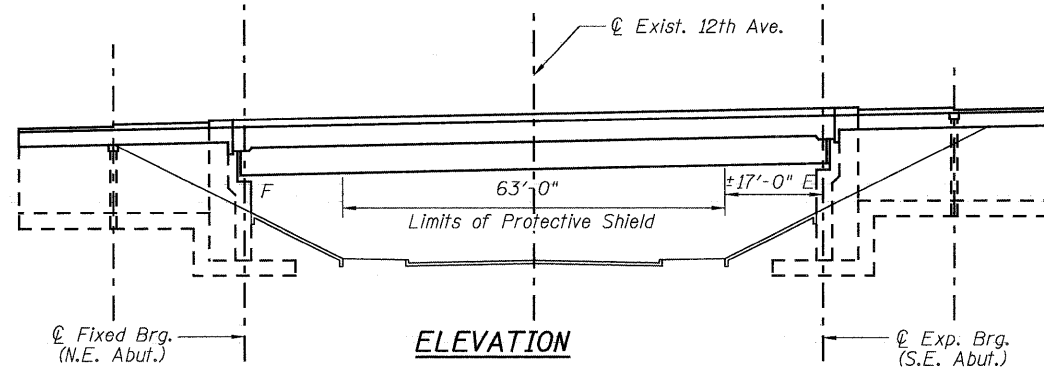

PROJECT LOCATION

DESIGNED	DFM
CHECKED	DSG
DRAWN	EBS
CHECKED	DFM

**GENERAL NOTES**

No field welding is permitted except as specified in the contract documents.

Reinforcement bars shall conform to the requirements of ASTM A706 Grade 60. See Special Provisions.

Reinforcement bars designated (E) shall be epoxy coated.

Plan dimensions and details relative to existing plans are subject to routine variations. The Contractor shall field verify existing dimensions and details affecting new construction and make necessary approved adjustments prior to construction or ordering materials. Such variations shall not be cause for additional compensation for a change in scope of work, however, the Contractor will be paid for the quantity actually furnished at the unit price bid for work.

Existing reinforcement bars extending into the removal area shall be cleaned, straightened and incorporated into the new construction. Any reinforcement bars that are damaged during concrete removal shall be replaced with approved bar splicer or anchorage system. Cost included with Concrete Removal.

Prior to pouring the new concrete deck, all heavy or loose rust, loose mill scale, and all other loose, potentially detrimental foreign material shall be removed from the surfaces in contact with concrete. Tightly adhered paint may remain unless otherwise noted. Removal shall be accomplished by methods that will not damage the steel and the cost will be included in the pay item covering removal of the existing concrete.

As directed by the Engineer, existing construction accessories welded to the top flange of beams and girders shall be removed. The weld areas shall be ground flush and inspected for cracks using magnetic particle testing (MT) or dye penetrant testing (PT) by an individual acceptable to the Engineer. Any cracks that can not be removed by grinding 1/4" deep shall be identified and reported to the Bureau of Bridges and Structures for further disposition. The cost of removing welded accessories, grinding and inspecting weld areas and grinding cracks will be paid for according to Article 109.04 of the Standard Specifications.

The existing structural steel coating contains lead. The contractor shall take appropriate precautions to deal with the presence of lead on this project.

Quantities of Deck Slab Repair (Full Depth, Type I), Deck Slab Repair (Full Depth, Type II) and Deck Slab Repair (Partial) are approximated. Locations will be determined by the Resident Engineer following removal of the Concrete Deck Overlay. Actual repair locations shall be shown on the as-built plans. Contractor will be paid for the quantities furnished.

Joint openings shall be adjusted according to article 520.04 of the standard specifications when the deck is poured at an ambient temperature other than 50° F.

STATE OF ILLINOIS  
DAVID F. MAXWELL  
081-005455  
ST. LOUIS, MO.  
LICENSED STRUCTURAL ENGINEER

*David F. Maxwell*  
David F. Maxwell, S.E. Reg. No. 061-005455  
Date: 9/10/08  
My registration expires November 30, 2010

**TOTAL BILL OF MATERIAL**

ITEM	UNIT	QUANTITY
Polymerized HMA Surface Course Mix "E", N70	TON	74
Concrete Removal	CU. YD.	12.4
Protective Shield	SQ. YD.	252
Concrete Superstructure	CU. YD.	12.4
Reinforcement Bars, Epoxy Coated	POUND	1390
Bar Splicers	EACH	22
Preformed Joint Strip Seal	FOOT	86
Waterproofing Membrane System	SQ. YD.	414.3
Bridge Deck Scarification	SQ. YD.	409.8
Deck Slab Repair (Full Depth, Type I)	SQ. YD.	22.7
Deck Slab Repair (Full Depth, Type II)	SQ. YD.	22.7
Deck Slab Repair (Partial)	SQ. YD.	50.5
Diamond Grinding (Bridge Section)	SQ. YD.	414.3

**PLAN AND ELEVATION**  
**F.A.I. 74 (OVER 12TH AVE.)**  
**ROCK ISLAND COUNTY**  
**STRUCTURE NO. 081-0102**

STATE OF ILLINOIS  
DEPARTMENT OF TRANSPORTATION

ROUTE NO.	SECTION	COUNTY	TOTAL SHEETS	SHEET NO.	SHEET NO. 2 10 SHEETS
FAI 74	*	ROCK ISLAND	246	159	
FED. ROAD DIST. NO. 7	ILLINOIS	FED. AID PROJECT-			

\* 81 (1-2, 1, 2-2) RS-1 & M

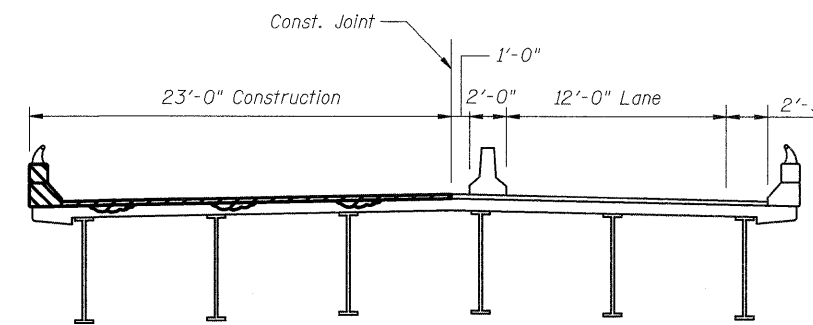
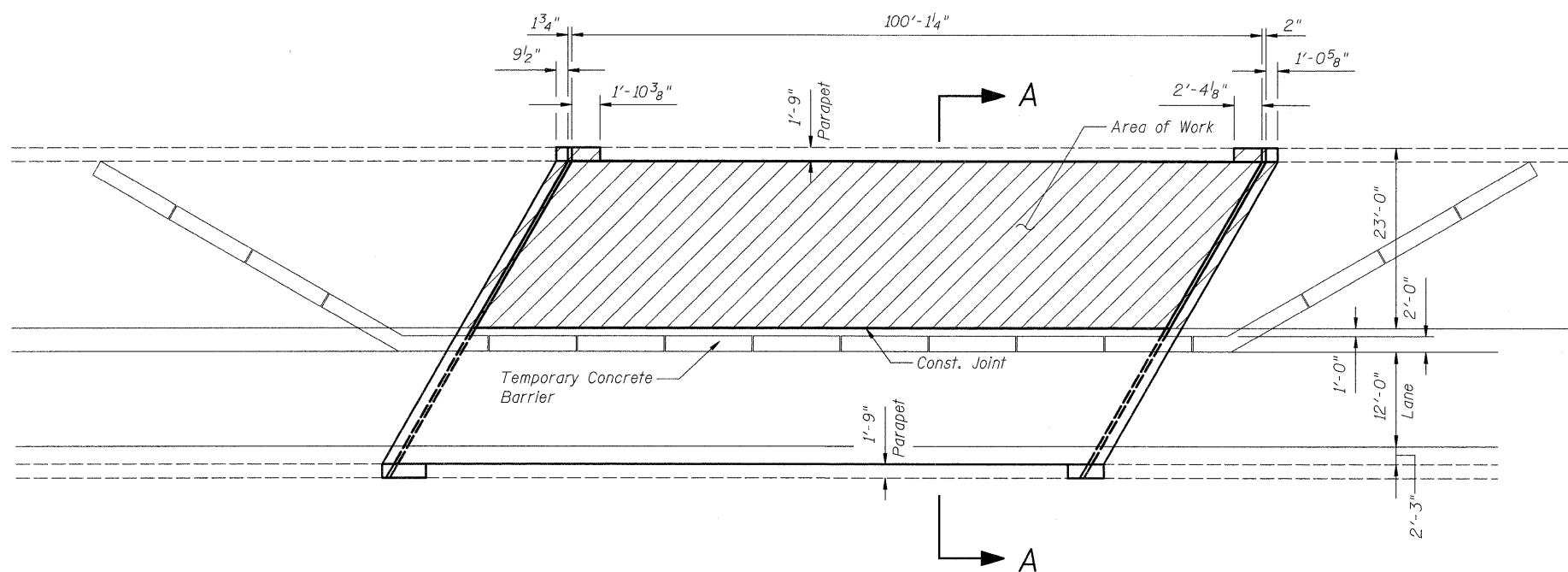

SECTION A-A

**STAGE I CONSTRUCTION**

- Install temporary concrete barrier as shown. \*
- Move traffic to Stage I traffic lane.
- Sawcut concrete wearing surface and remove.
- Replace Bridge Joints and repair deck.
- Install new wearing surface & waterproofing membrane.
- \* For temporary concrete barrier details, see sheet 9 of 10.

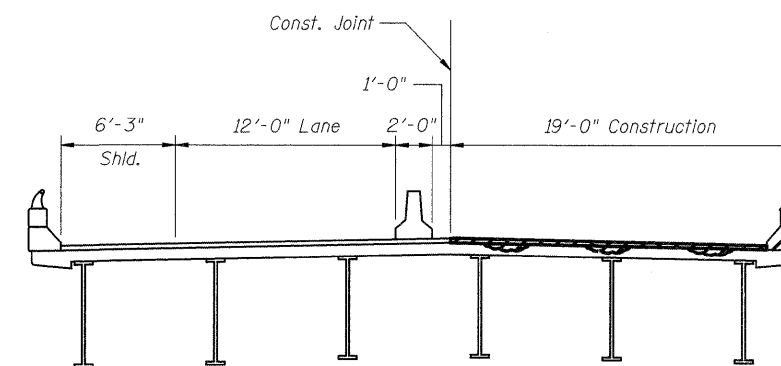
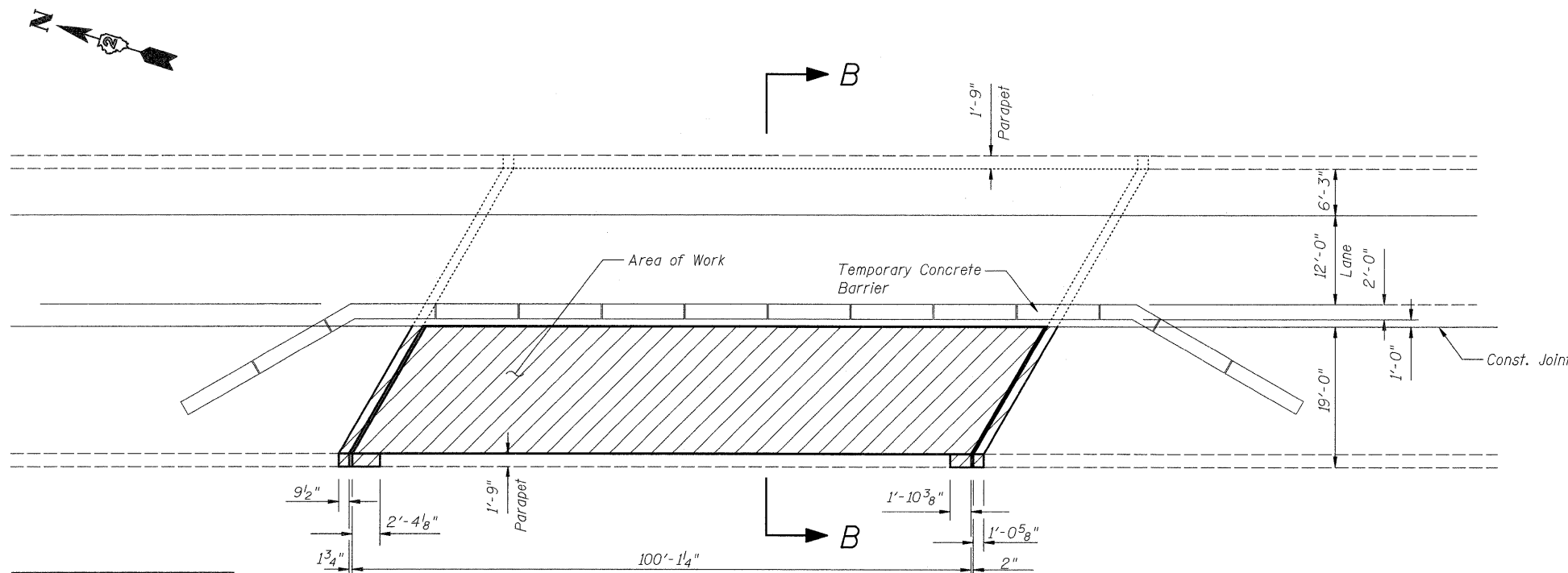

SECTION B-B

**STAGE II CONSTRUCTION**

- Relocate temporary concrete barrier as shown. \*
- Move traffic to Stage II traffic lane.
- Remove concrete wearing surface.
- Replace bridge joints and repair deck.
- Install new wearing surface & waterproofing membrane.
- Remove temporary concrete barrier.

DESIGNED	DFM
CHECKED	DSG
DRAWN	EBS
CHECKED	DFM

**STAGING PLAN**  
**F.A.I. 74 (OVER 12TH AVE.)**  
**ROCK ISLAND COUNTY**  
**STRUCTURE NO. 081-0102**

STATE OF ILLINOIS  
DEPARTMENT OF TRANSPORTATION

ROUTE NO.	SECTION	COUNTY	TOTAL SHEETS	SHEET NO.	SHEET NO. 3
FAI 74	*	ROCK ISLAND	246	160	10 SHEETS
FED. ROAD DIST. NO. 7	ILLINOIS	FED. AID PROJECT-			

\* 81 (1-2, 1, 2-2) RS-1 & M

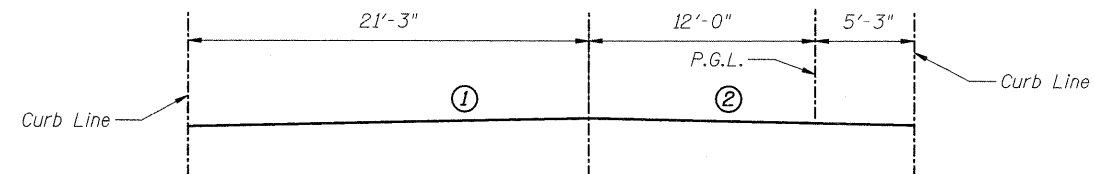

CURRENT STATION	ORIGINAL STATION	SLOPE ①	SLOPE ②
72+90.90	299+75	0.0238	0.007
73+15.90	300+00	0.0192	-0.0007
73+40.90	300+25	0.0167	-0.008
73+65.90	300+50	0.0158	-0.012
73+90.90	300+75	0.0156	-0.0156

**BILL OF MATERIAL**

ITEM	UNIT	QUANTITY
Polymerized HMA Surface Course Mix "E", N90	TON	74
Protective Shield	SQ. YD.	252
Waterproofing Membrane System	SQ. YD.	414.3
Bridge Deck Scarification	SQ. YD.	409.8

**EXISTING SLOPE CONFIGURATION**

(Looking South)

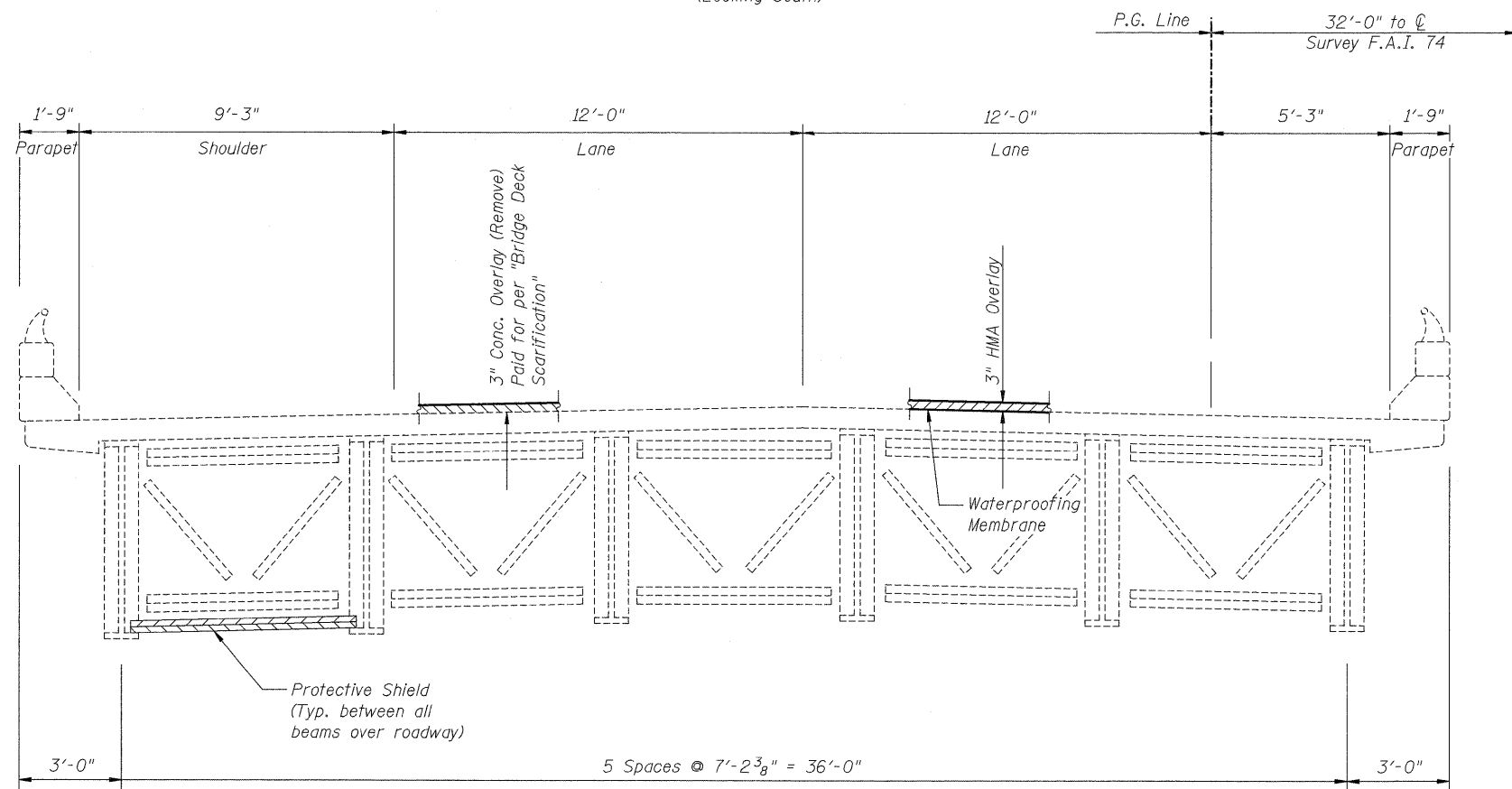

**CROSS SECTION**

(Looking South)

DESIGNED	DFM
CHECKED	DSG
DRAWN	EBS
CHECKED	DFM

**BRIDGE REPAIR DETAILS**  
**F.A.I. 74 (OVER 12TH AVE.)**  
**ROCK ISLAND COUNTY**  
**STRUCTURE NO. 081-0102**

STATE OF ILLINOIS  
DEPARTMENT OF TRANSPORTATION

ROUTE NO. FAI 74	SECTION *	COUNTY ROCK ISLAND	TOTAL SHEETS 246	SHEET NO. 161	SHEET NO. 4 10 SHEETS
FED. ROAD DIST. NO. 7		ILLINOIS		FED. AID PROJECT	

\* 81 (1-2, 1, 2-2) RS-1 & M

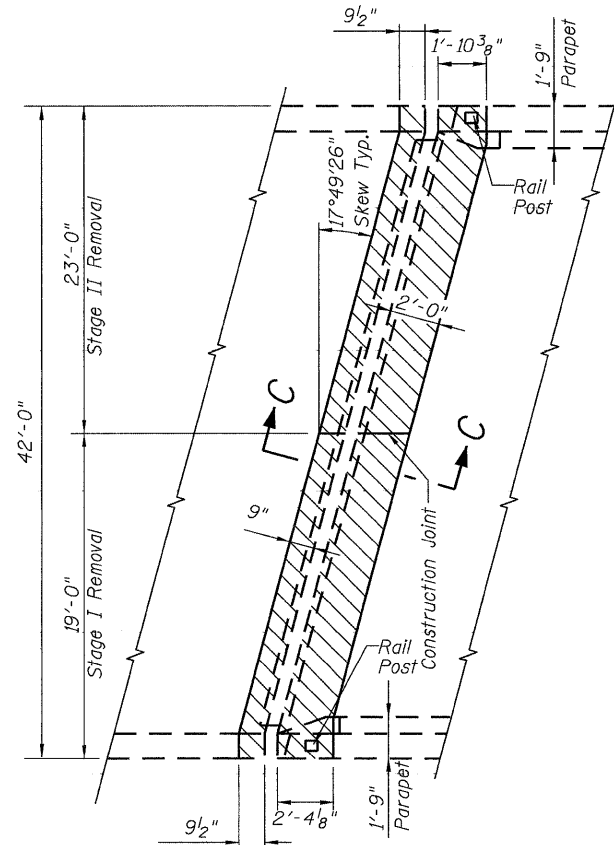

EXISTING PARTIAL PLAN - NORTH ABUTMENT

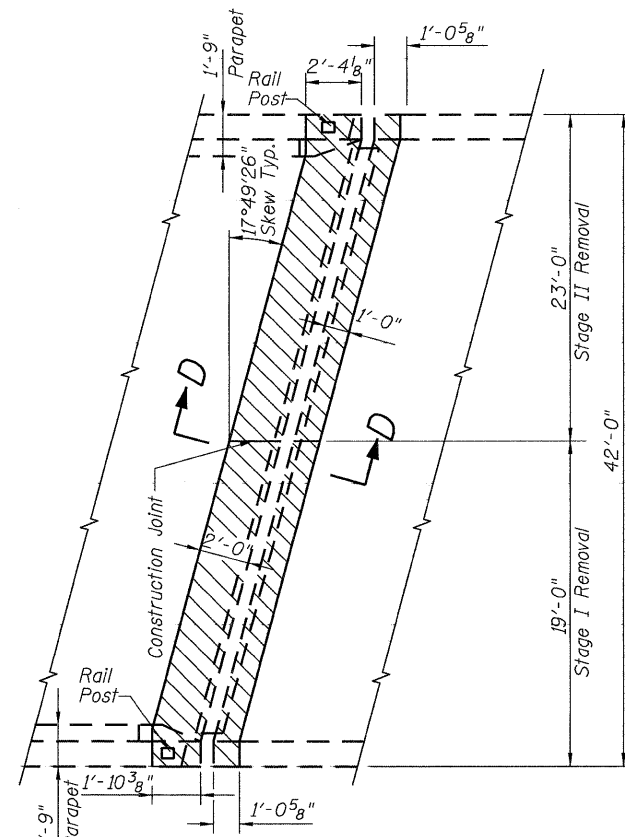

EXISTING PARTIAL PLAN - SOUTH ABUTMENT

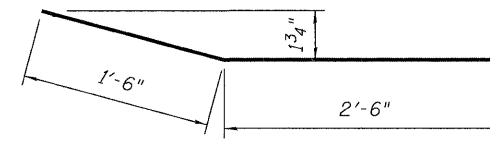

BAR a (E)

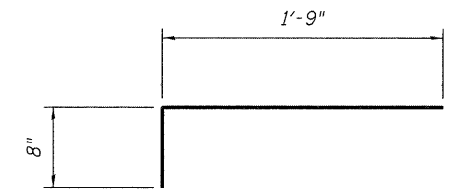

BAR s (E)

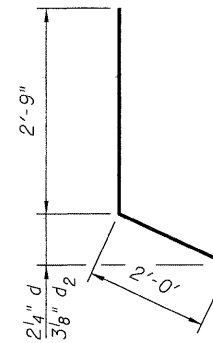

BAR d (E) & d<sub>2</sub> (E)

BILL OF MATERIAL

BAR	NO.	SIZE	LENGTH	SHAPE
a (E)	10	#6	4'-0"	
a <sub>1</sub> (E)	16	#5	18'-5"	
a <sub>2</sub> (E)	16	#5	23'-0"	
a <sub>3</sub> (E)	6	#6	18'-5"	
a <sub>4</sub> (E)	6	#6	23'-0"	
d	5	#4	4'-9"	
d <sub>1</sub>	10	#5	2'-9'	
d <sub>2</sub>	5	#4	4'-9"	
d <sub>3</sub>	8	#4	2'-1'	
s (E)	78	#5	2'-5"	└┘
Reinforcement Bars Epoxy Coated			Pound	1390
Concrete Removal			Cu. Yd.	12.4
Concrete Superstructure			Cu. Yd.	12.4
Bar Splicer			Each	22

For bar splicer assembly details see sheet 8 of 10.

For Sections C-C & D-D, see sheet 5 of 10.

For rail post details, see sheet 10 of 10.

LEGEND

- Concrete Removal
- Concrete Superstructure

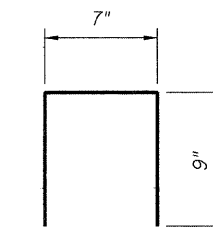

BAR d<sub>3</sub> (E)

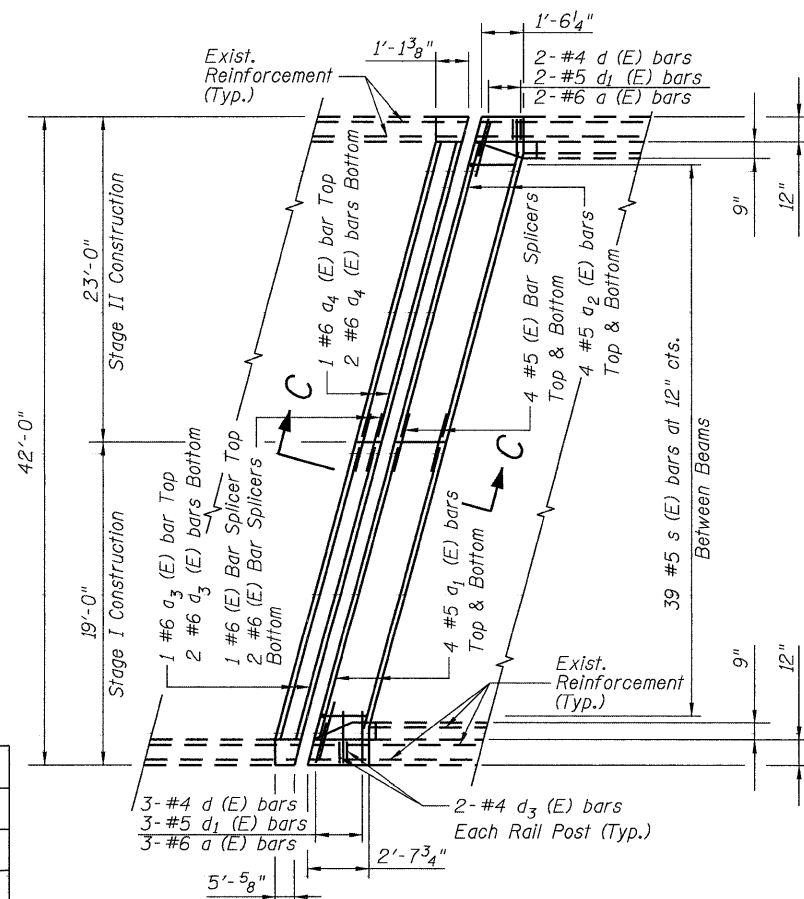

PROPOSED PARTIAL PLAN - NORTH ABUTMENT

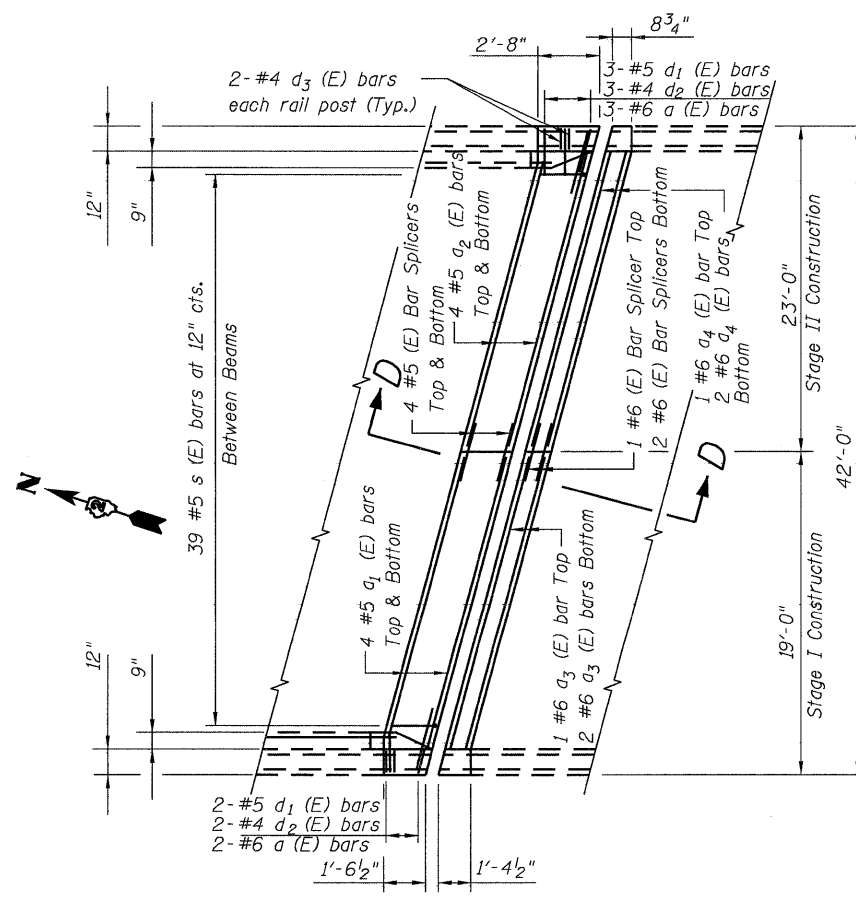

PROPOSED PARTIAL PLAN - SOUTH ABUTMENT

DESIGNED	DFM
CHECKED	DSG
DRAWN	EBS
CHECKED	DFM

JOINT RECONSTRUCTION DETAILS  
F.A.I. 74 (OVER 12TH AVE.)  
ROCK ISLAND COUNTY  
STRUCTURE NO. 081-0102

STATE OF ILLINOIS  
DEPARTMENT OF TRANSPORTATION

ROUTE NO.	SECTION	COUNTY	TOTAL SHEETS	SHEET NO.	SHEET NO. 5 10 SHEETS
FAI 74	*	ROCK ISLAND	246	162	
FED. ROAD DIST. NO. 7		ILLINOIS	FED. AID PROJECT-		

\* 81 (1-2, 1, 2-2) RS-1 & M

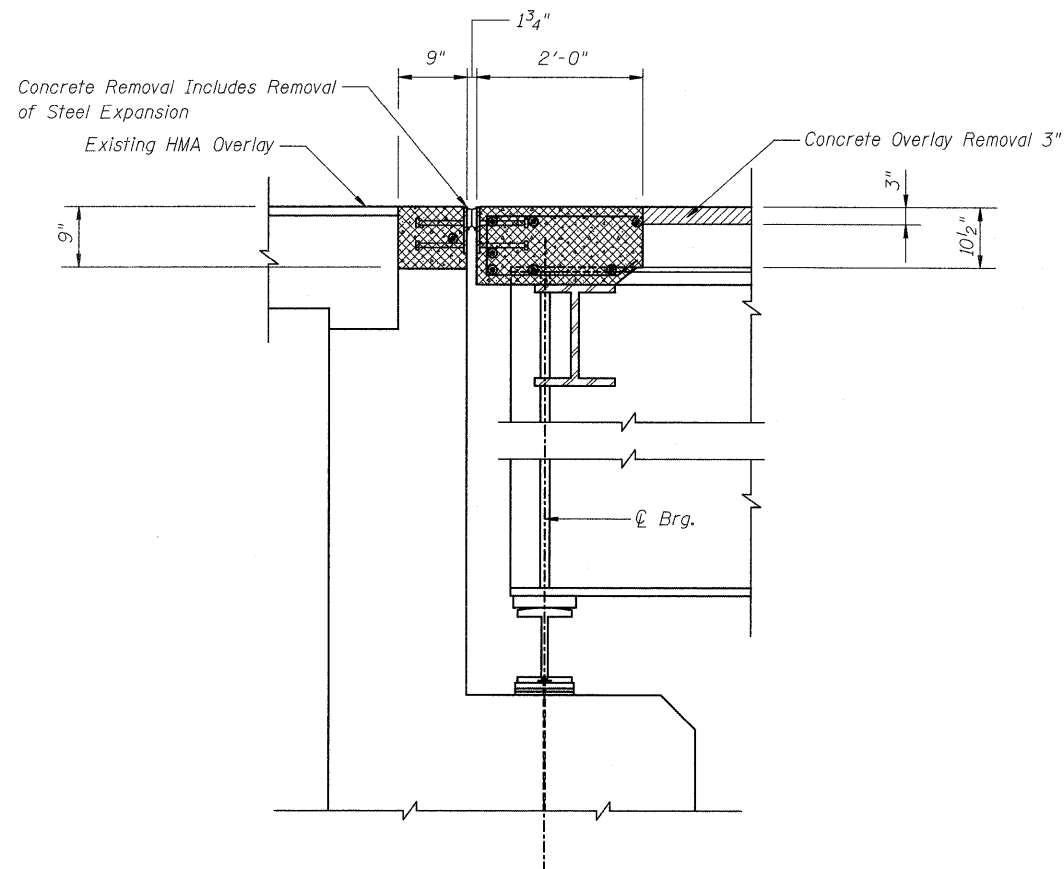

EXISTING SECTION C-C THRU NORTH ABUTMENT

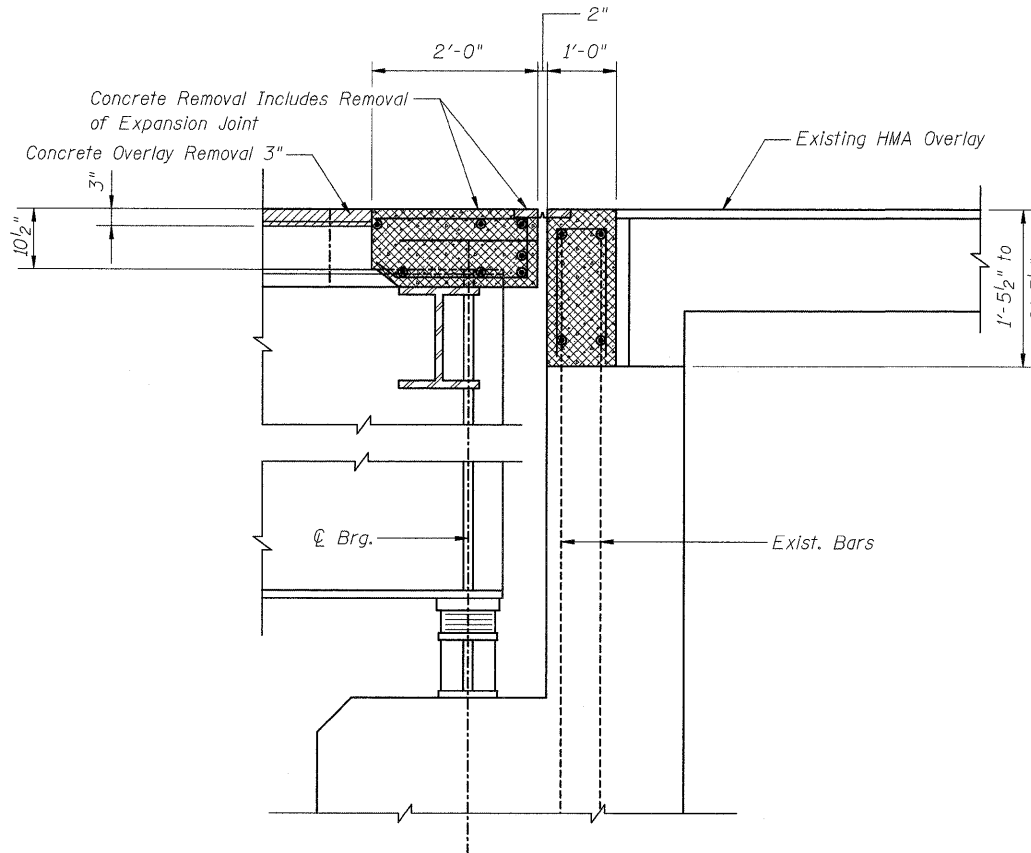

EXISTING SECTION D-D THRU SOUTH ABUTMENT

LEGEND

- Concrete Removal
- Bridge Deck Scarification

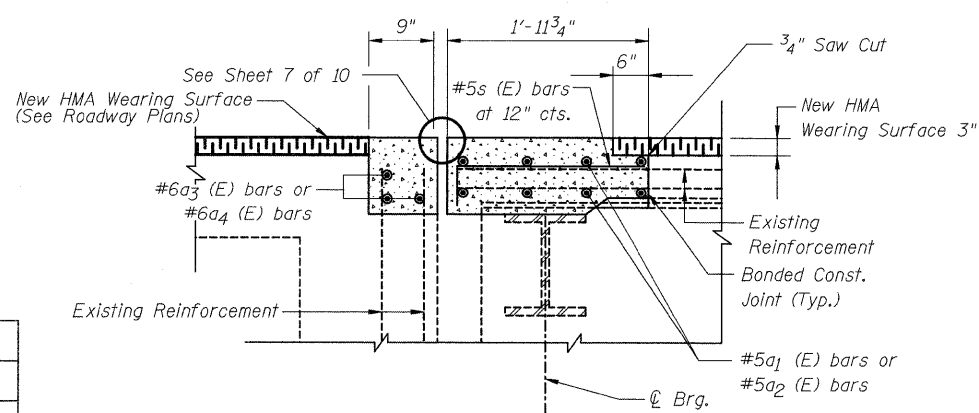

PROPOSED SECTION C-C THRU NORTH ABUTMENT

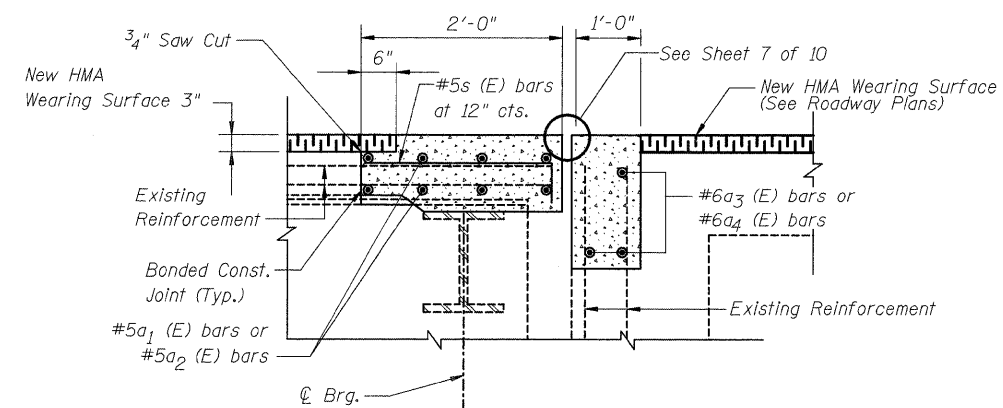

PROPOSED SECTION D-D THRU SOUTH ABUTMENT

DESIGNED	DFM
CHECKED	DSG
DRAWN	EBS
CHECKED	DFM

JOINT RECONSTRUCTION DETAILS  
F.A.I. 74 (OVER 12TH AVE.)  
ROCK ISLAND COUNTY  
STRUCTURE NO. 081-0102

STATE OF ILLINOIS  
DEPARTMENT OF TRANSPORTATION

ROUTE NO.	SECTION	COUNTY	TOTAL SHEETS	SHEET NO.	SHEET NO. 6 10 SHEETS
FAI 74	*	ROCK ISLAND	246	163	
FED. ROAD DIST. NO. 7		ILLINOIS	FED. AID PROJECT-		

\* 81 (1-2, 1, 2-2) RS-1 & M

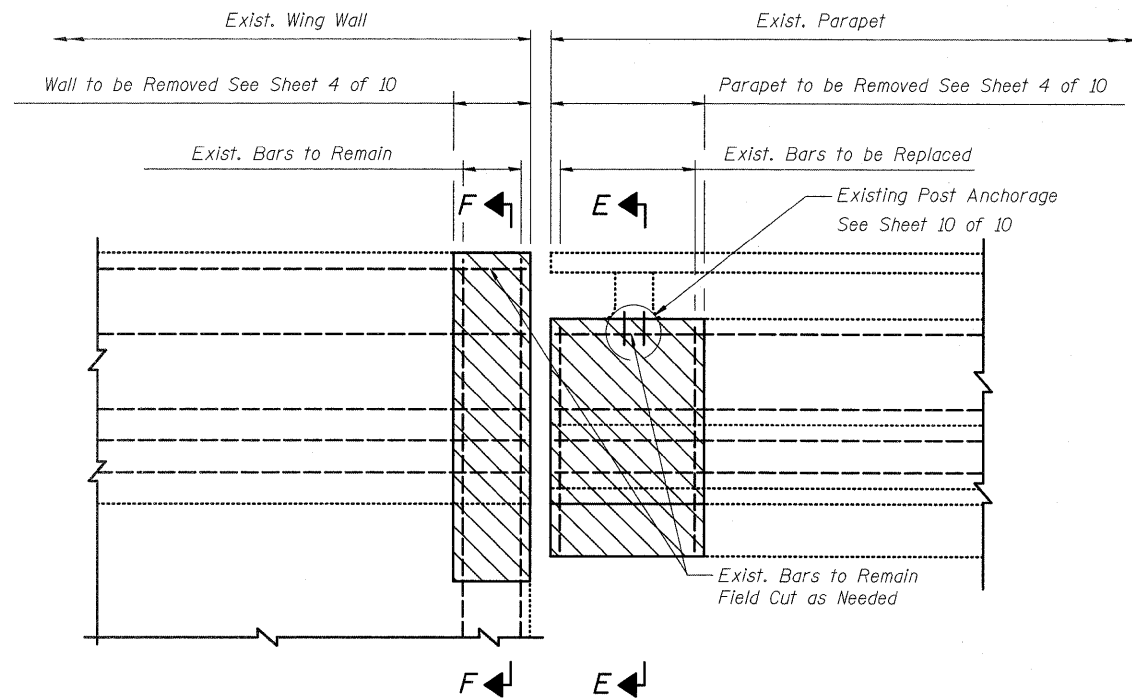

**ELEVATION OF CONCRETE REMOVAL THRU PARAPET AND WING WALL**

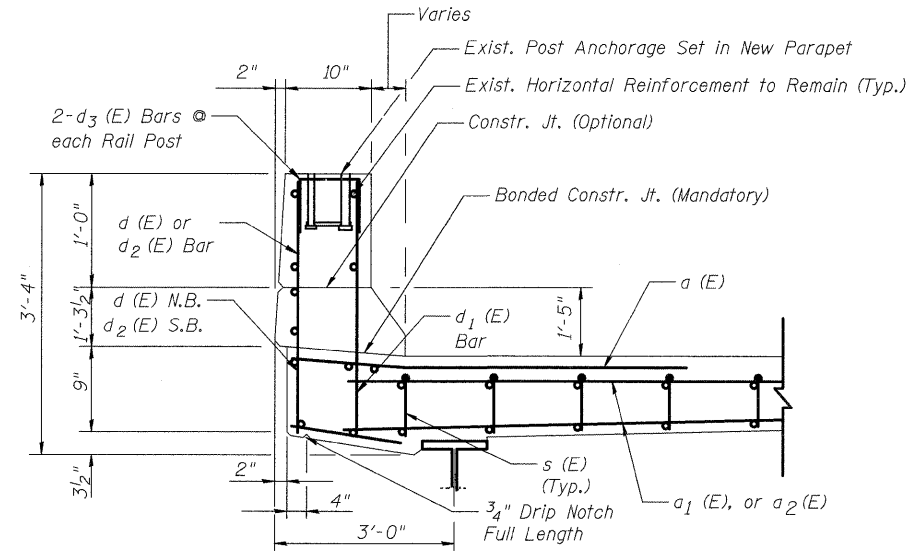

**SECTION E-E THRU BRIDGE DECK PARAPET**

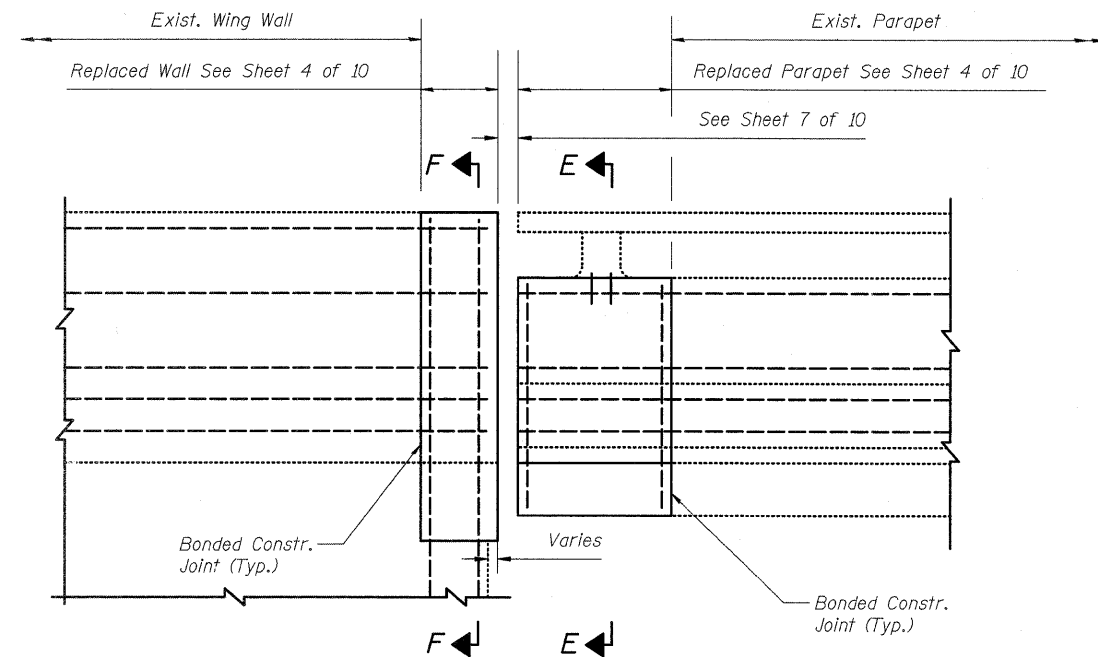

**ELEVATION OF CONCRETE REPLACEMENT THRU PARAPET AND WING WALL**

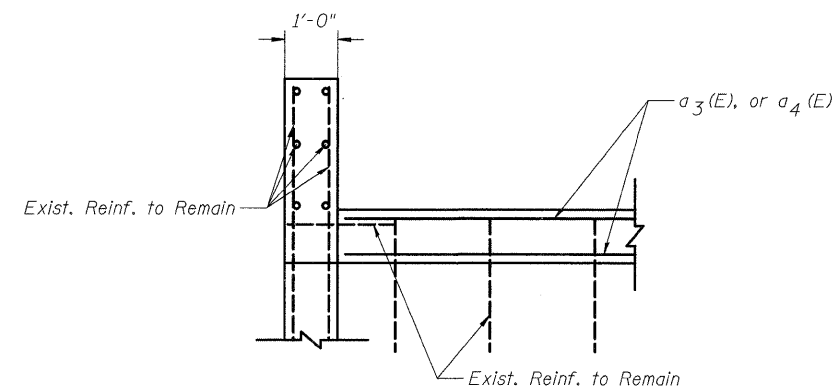

**SECTION F-F THRU ABUTMENT BACKWALL AND WING WALL**

DESIGNED	DFM
CHECKED	DSG
DRAWN	EBS
CHECKED	DFM

Hatched areas indicate concrete sections to be removed and replaced. Perimeters of concrete removal areas shall be saw cut  $\frac{3}{4}$ " prior to the removal of concrete.

**PARAPET AND RETAINING WALL DETAILS**  
**F.A.I. 74 (OVER 12TH AVE.)**  
**ROCK ISLAND COUNTY**  
**STRUCTURE NO. 081-0102**

STATE OF ILLINOIS  
DEPARTMENT OF TRANSPORTATION

ROUTE NO.	SECTION	COUNTY	TOTAL SHEETS	SHEET NO.	SHEET NO. 7
FAI 74	*	ROCK ISLAND	246	164	10 SHEETS
FED. ROAD DIST. NO. 7	ILLINOIS	FED. AID PROJECT-			

\*Granular or solid flux filled headed studs conforming to Article 1006.32 of the Std. Specs., automatically end welded.

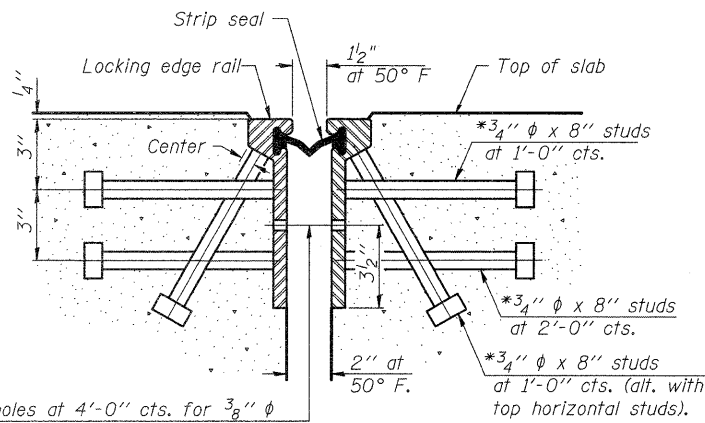

7/16" φ holes at 4'-0" cts. for 3/8" φ bolts. All bolts shall be burned, sawed, or chipped off flush with the plates after forms are removed, typ.

SECTION THRU ROLLED RAIL JOINT

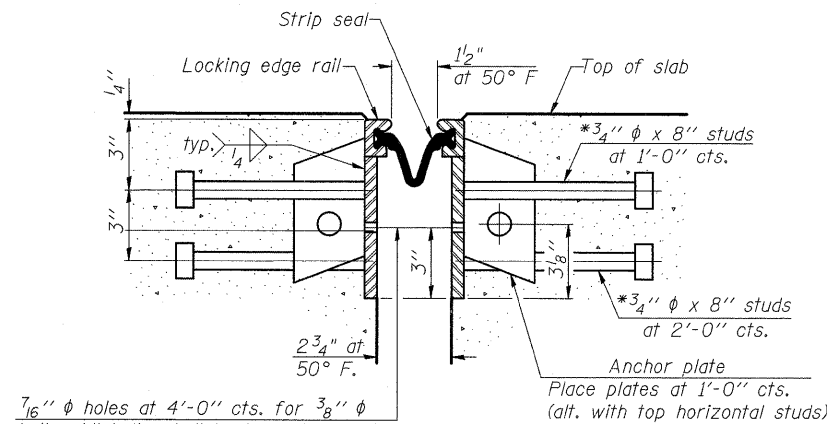

7/16" φ holes at 4'-0" cts. for 3/8" φ bolts. All bolts shall be burned, sawed, or chipped off flush with the plates after forms are removed, typ.

SECTION THRU WELDED RAIL JOINT

Notes:

The strip seal shall be made continuous and shall have a minimum thickness of 1/4". The configuration of the strip seal shall match the configuration of the Locking Edge Rails. Open or "webbed" strip seal gland configurations are not permitted. The gland shall be sized for a maximum rated movement of 4 inches.

The height and thickness of the Locking Edge Rails shown are minimum dimensions. The actual configuration of the Locking Edge Rails and matching strip seal may vary from manufacturer to manufacturer. Flanged edge rails will not be allowed. Locking Edge Rails may be spliced at slope discontinuities and stage construction joints.

The manufacturer's recommended installation methods shall be followed. The joint opening and deck dimensions detailed on the superstructure are based on a rolled rail expansion joint. If the Contractor elects to use the welded rail expansion joint, the opening and deck dimensions shall be modified according to the dimensions detailed on this sheet. Required modifications shall be made at no additional cost to the State.

All steel components shall be galvanized after fabrication according to Article 520.03 of the Standard Specifications.

\* 81 (1-2, 1, 2-2) RS-1 & M

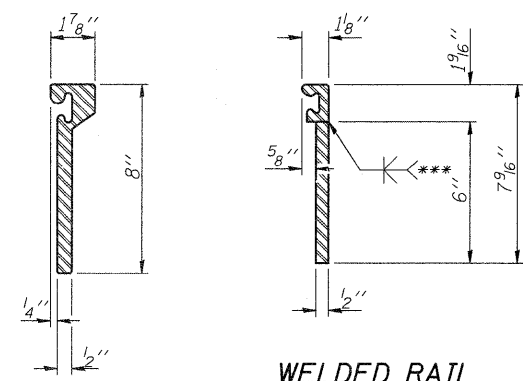

ROLLED EXTRUDED RAIL

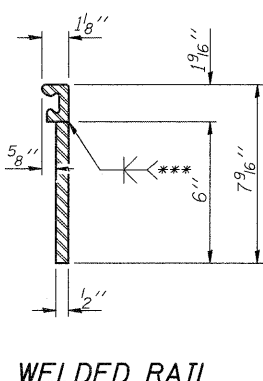

WELDED RAIL

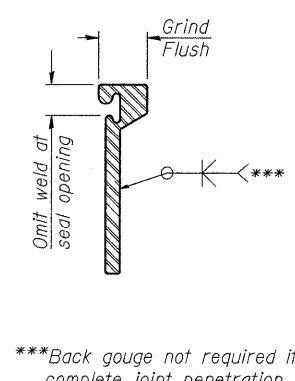

LOCKING EDGE RAIL SPLICE

The inside of the locking edge rail groove shall be free of weld residue.

\*\*\*Back gouge not required if complete joint penetration is verified by mock-up.

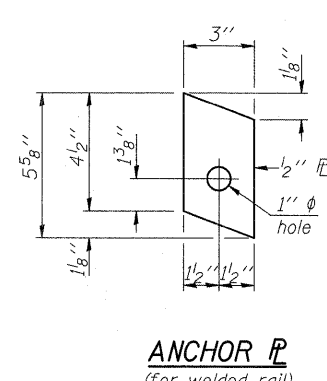

ANCHOR PLATE  
(for welded rail)

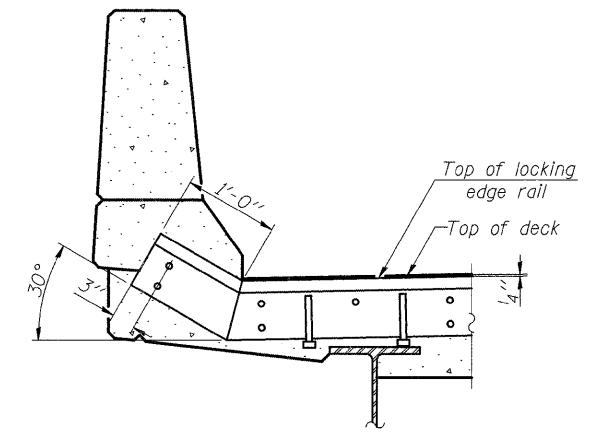

AT PARAPET

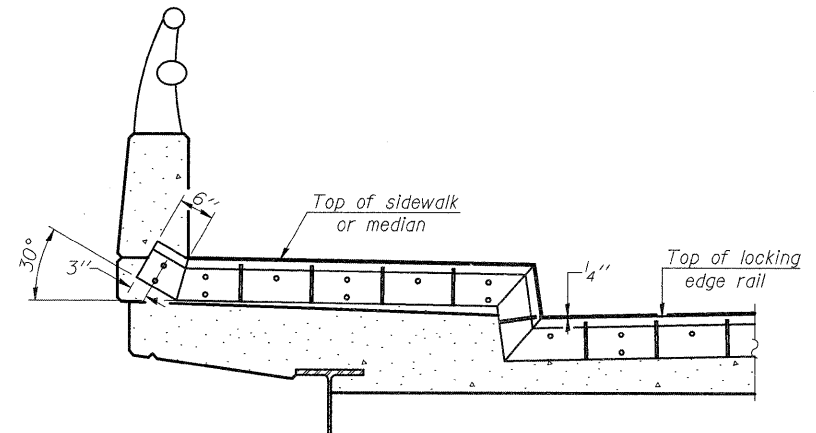

AT SIDEWALK OR MEDIAN

Shorter plates with a single row of studs at 12" cts. may be necessary on medians which are shallower than 9". See manufacturer's recommendation.

LOCKING EDGE RAILS

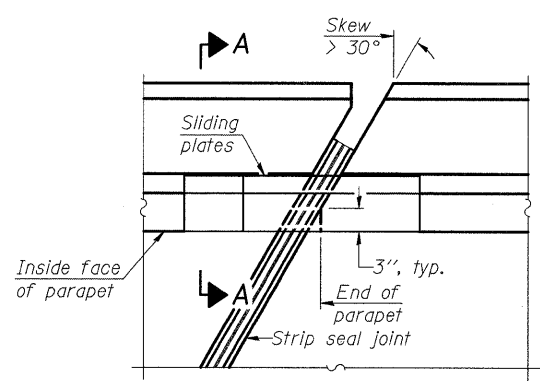

PLAN

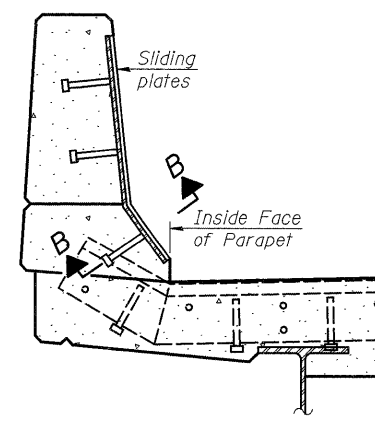

SECTION A-A

POINT BLOCK DETAILS  
(for skews > 30°)

TYPICAL END TREATMENTS

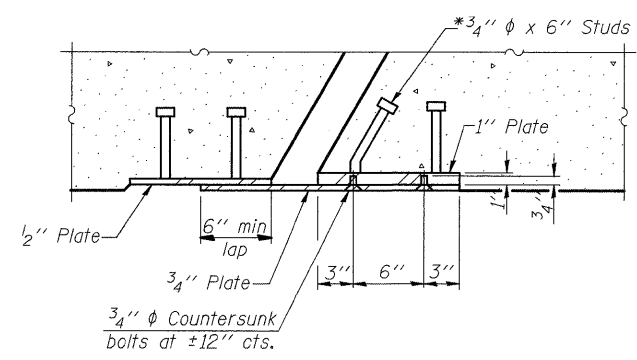

SECTION B-B

BILL OF MATERIAL

Item	Unit	Total
Preformed Joint Strip Seal	Foot	86

DESIGNED	DFM
CHECKED	DSG
DRAWN	EBS
CHECKED	DFM
EJ-SSJ	

PREFORMED JOINT STRIP SEAL  
F.A.I. 74 (OVER 12TH AVE.)  
ROCK ISLAND COUNTY  
STRUCTURE NO. 081-0102



STATE OF ILLINOIS  
DEPARTMENT OF TRANSPORTATION

ROUTE NO.	SECTION	COUNTY	TOTAL SHEETS	SHEET NO.	SHEET NO. 8
FAI 74	*	ROCK ISLAND	246	165	10 SHEETS
FED. ROAD DIST. NO. 7	ILLINOIS	FED. AID PROJECT-			

\* 81 (1-2, 1, 2-2) RS-1 & M

**NOTES**

Bar splicer assemblies shall be of an approved type and shall develop in tension at least 125 percent of the yield strength of the lapped reinforcement bars.  
Splicer rods shall be of minimum 60 ksi yield strength, threaded or coiled full length.  
All reinforcement bars shall be lapped and tied to the splicer rods or dowel bars.  
Bar splicer assemblies shall be epoxy coated according to the requirements for reinforcement bars.  
Other systems of similar design may be submitted to the Engineer for approval. Approval shall be based on certified test results from an approved testing laboratory that the proposed bar splicer assembly satisfies the following requirements:

- ① Minimum Capacity =  $1.25 \times f_y \times A_t$   
(Tension in kips)
  - ② Minimum \*Pull-out Strength =  $0.66 \times f_y \times A_t$   
(Tension in kips)
- Where  $f_y$  = Yield strength of lapped reinforcement bars in ksi.  
 $A_t$  = Tensile stress area of lapped reinforcement bars.  
\* = 28 day concrete

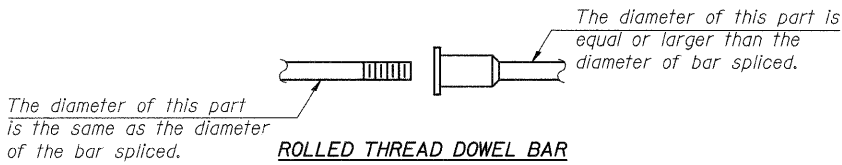

ROLLED THREAD DOWEL BAR



\*\* ONE PIECE

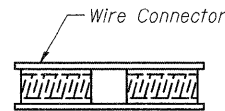

WELDED SECTIONS

**BAR SPLICER ASSEMBLY ALTERNATIVES**

\*\*Heavy Hex Nuts conforming to ASTM A 563, Grade C, D or DH may be used.

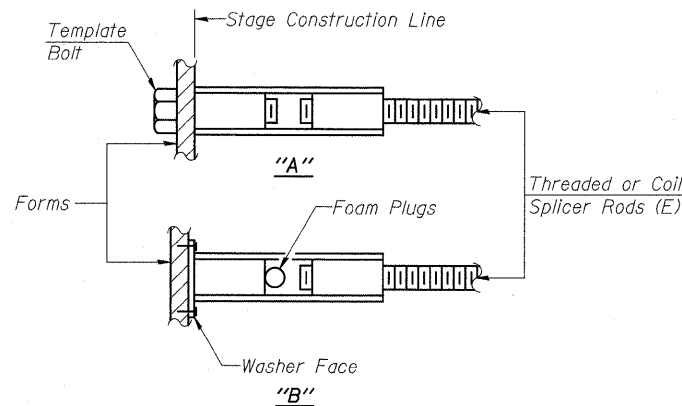

**INSTALLATION AND SETTING METHODS**

"A" :Set bar splicer assembly by means of a template bolt.  
"B" :Set bar splicer assembly by nailing to wood forms or cementing to steel forms.  
(E) : Indicates epoxy coating.

BAR SPLICER ASSEMBLIES			
Bar Size to be Spliced	Splicer Rod or Dowel Bar Length	Strength Requirements	
		Min. Capacity kips - tension	Min. Pull-Out Strength kips - tension
#4	1'-8"	14.7	7.9
#5	2'-0"	23.0	12.3
#6	2'-7"	33.1	17.4
#7	3'-5"	45.1	23.8
#8	4'-6"	58.9	31.3
#9	5'-9"	75.0	39.6
#10	7'-3"	95.0	50.3
#11	9'-0"	117.4	61.8

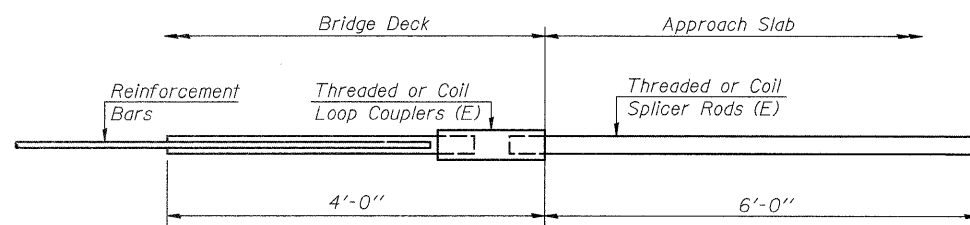

FOR INTEGRAL OR SEMI-INTEGRAL ABUTMENTS

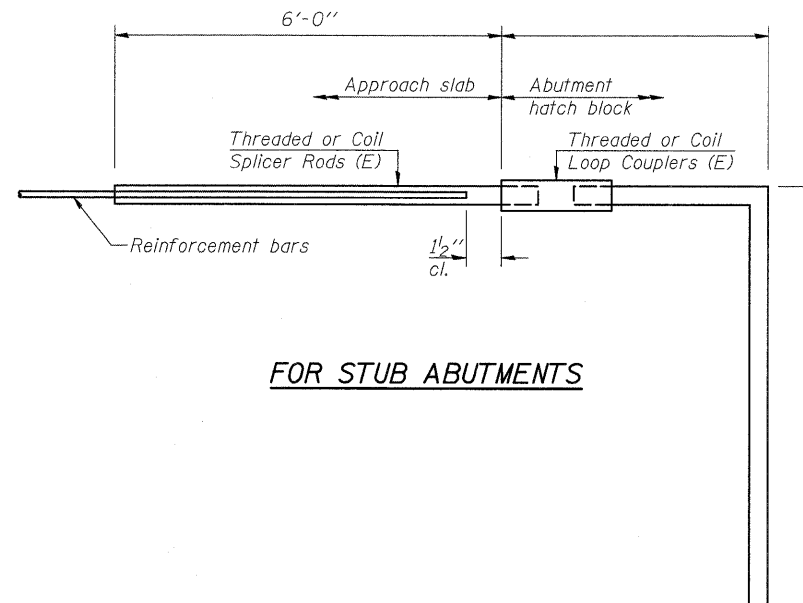

FOR STUB ABUTMENTS

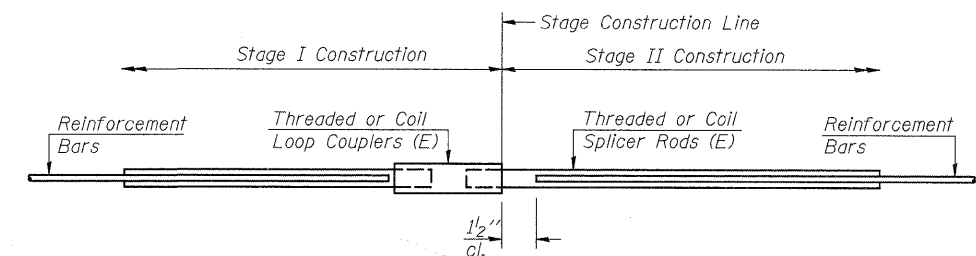

STANDARD

Bar Splicer for #5 bar
Min. Capacity = 23.0 kips - tension
Min. Pull-out Strength = 12.3 kips - tension
No. Required =

Bar Splicer for #5 bar
Min. Capacity = 23.0 kips - tension
Min. Pull-out Strength = 12.3 kips - tension
No. Required =

Bar Size	No. Assemblies Required	Location
#5	8	Bridge Deck at South Abutment
#5	8	Bridge Deck at North Abutment
#6	3	South Abutment Backwall
#6	3	North Abutment Backwall

DESIGNED	DFM
CHECKED	DSG
DRAWN	EBS
CHECKED	DFM

BSD-1

5-16-08

**BAR SPLICER ASSEMBLY DETAILS**  
F.A.I. 74 (OVER 12TH AVE.)  
ROCK ISLAND COUNTY  
STRUCTURE NO. 081-0102

STATE OF ILLINOIS  
DEPARTMENT OF TRANSPORTATION

ROUTE NO.	SECTION	COUNTY	TOTAL SHEETS	SHEET NO.	SHEET NO. 9
FAI 74	*	ROCK ISLAND	246	166	10 SHEETS
FED. ROAD DIST. NO. 7	ILLINOIS	FED. AID PROJECT-			

\* 81 (1-2, 1, 2-2) RS-1 & M

When "A" is 3'-6" or less, the temporary concrete barrier shall be anchored to the new slab according to Detail I or Detail II. No anchorage is required when "A" is greater than 3'-6".

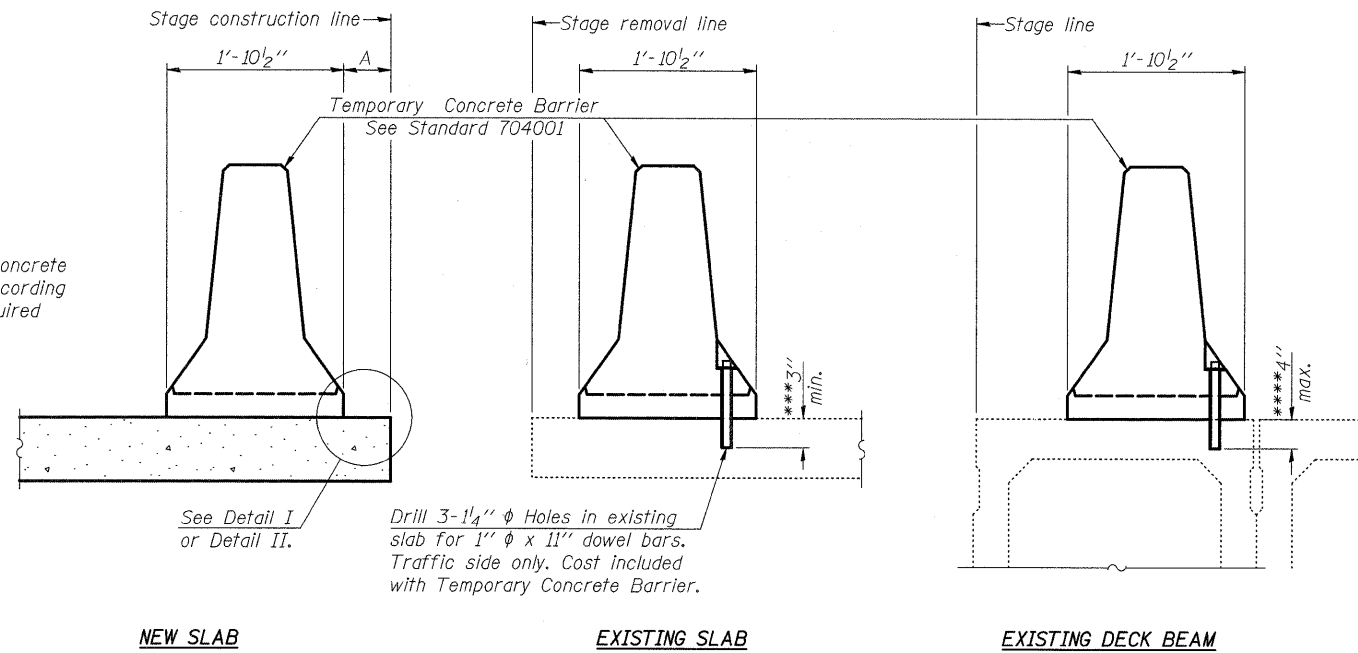

SECTIONS THRU SLAB OR DECK BEAM

NOTES

Detail I - With Bar Splicer or Couplers:  
Connect one (1) 1"x7"x10" steel PL to the top layer of couplers with 2-5/8" φ bolts screwed to coupler at approximate C of each barrier panel.

Detail II - With Extended Reinforcement Bars:  
Connect one (1) 1"x7"x10" steel PL to the concrete slab or concrete wearing surface with 2-5/8" φ Expansion Anchors or cast in place inserts spaced between the top layer of reinforcement at approximate C of each barrier panel.

Cost of anchorage is included with Temporary Concrete Barrier. The 1" x 7" x 10" plate shall not be removed until stage II construction forms and all reinforcement bars are in place and the concrete is ready to be placed.

\*\*\*Dimension shown is minimum required embedment into concrete. If hot-mix asphalt wearing surface is present, minimum embedment shall be in addition to wearing surface depth.

\*\*\*\*If existing deck beam is to remain in place after stage construction, embedment shall only be into wearing surface and not into existing deck beam concrete.

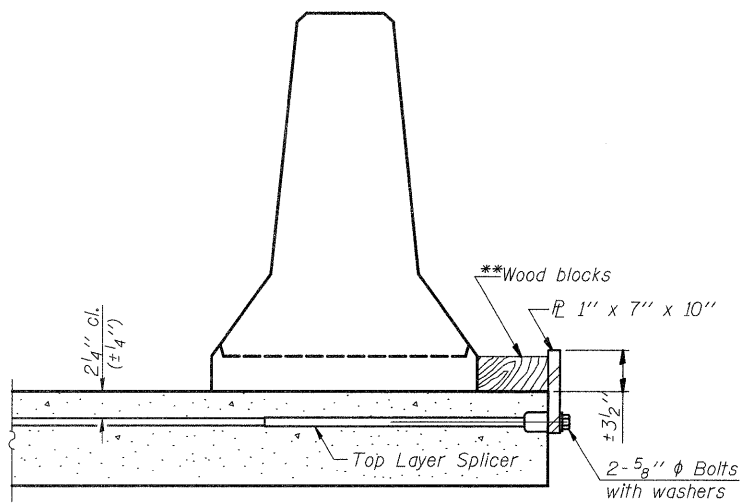

DETAIL I

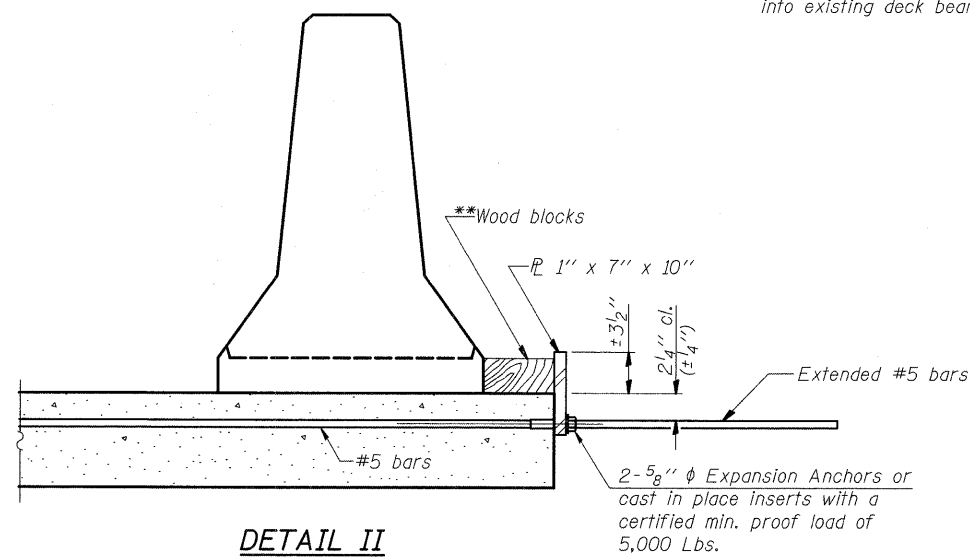

DETAIL II

\*\*Wood blocks may be omitted when required to provide minimum stage traffic lane width. When the wood blocks are omitted, the concrete barrier shall be in direct contact with the steel retainer plate.

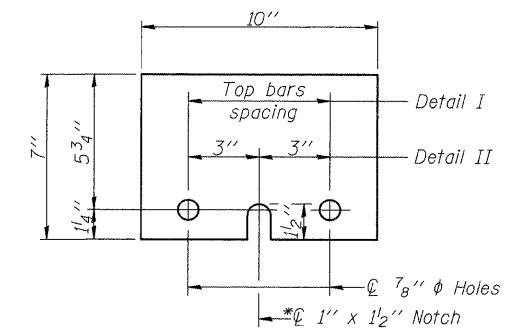

STEEL RETAINER PL 1" x 7" x 10"

\*Required only with Detail II

TEMPORARY CONCRETE BARRIER  
FOR STAGE CONSTRUCTION  
F.A.I. 74 (OVER 12TH AVE.)  
ROCK ISLAND COUNTY  
STRUCTURE NO. 081-0102

DESIGNED	DFM
CHECKED	DSG
DRAWN	EBS
CHECKED	DFM

STATE OF ILLINOIS  
DEPARTMENT OF TRANSPORTATION

ROUTE NO.	SECTION	COUNTY	TOTAL SHEETS	SHEET NO.	SHEET NO.
FAI 74	*	ROCK ISLAND	246	167	10 SHEETS
FED. ROAD DIST. NO. 7	ILLINOIS	FED. AID PROJECT-			

\* 81 (1-2, 1, 2-2) RS-1 & M

**NOTE:**  
Seal perimeter of post to parapet with two component non-staining gray sealing compound with polysulfide liquid polymers-gun grade with primer.

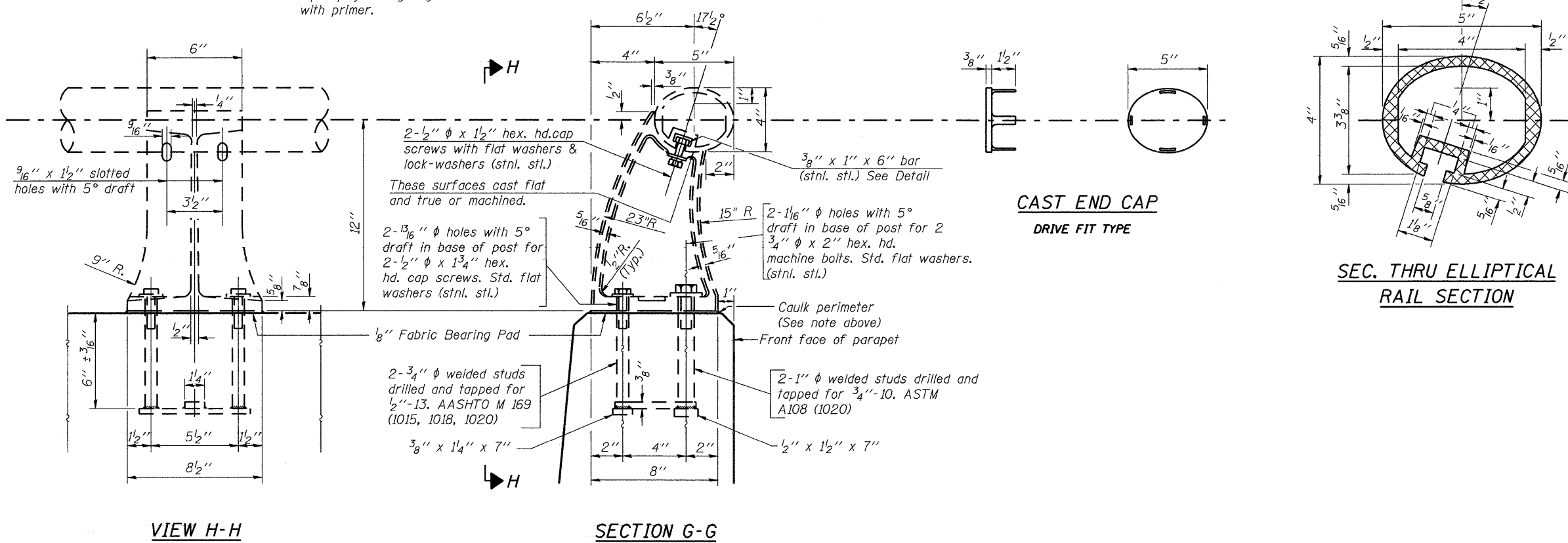

**RAIL POST DETAILS**

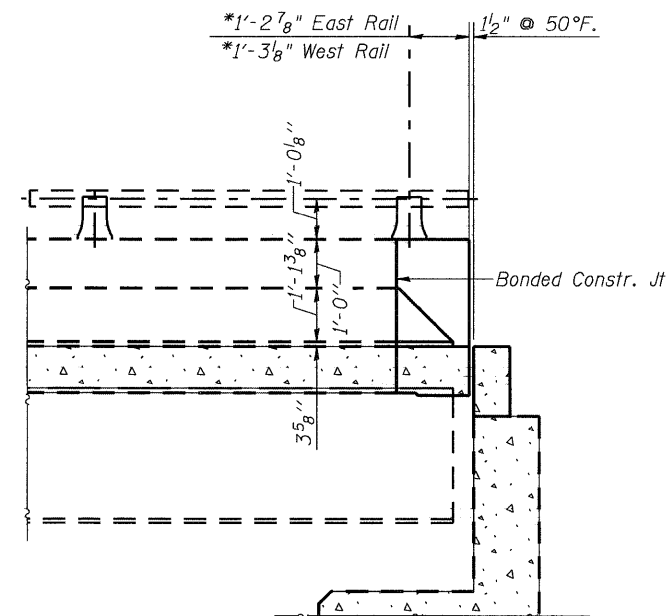
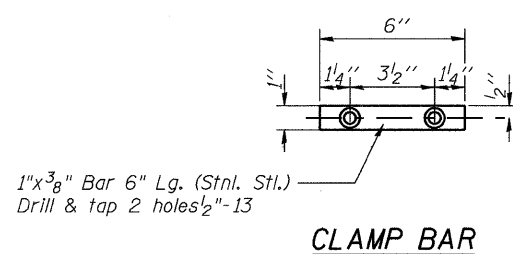

**INSIDE VIEW AT PROPOSED ABUTMENTS**

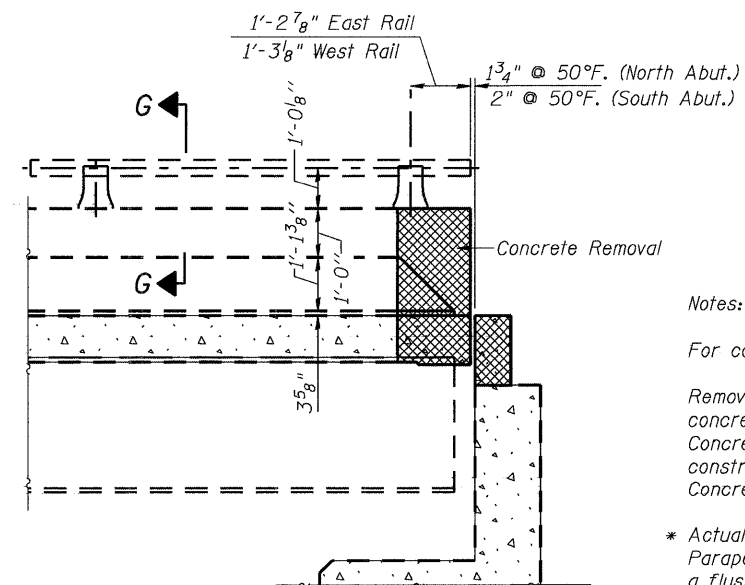

**INSIDE VIEW AT EXISTING ABUTMENTS**

Notes:

For concrete removal limits See Sheet 4 of 10.

Remove and reuse railing, including posts and anchors, where concrete removal affects existing rail posts. Cost included with Concrete Superstructure. If anchors are damaged during construction, they shall be replaced and are included with Concrete Removal.

\* Actual distance varies. New Joints are skewed through Parapet. Length of rail shall be adjusted as necessary with a flush cut and the cast end cap shall be reused.

DESIGNED	DFM
CHECKED	DSG
DRAWN	EBS
CHECKED	DFM

**RAILING DETAILS**  
**F.A.I. 74 (OVER 12TH AVE.)**  
**ROCK ISLAND COUNTY**  
**STRUCTURE NO. 081-0102**

STATE OF ILLINOIS  
DEPARTMENT OF TRANSPORTATION

ROUTE NO. FAI 74	SECTION *	COUNTY ROCK ISLAND	TOTAL SHEETS 246	SHEET NO. 168
FED. ROAD DIST. NO. 7		ILLINOIS	FED. AID PROJECT-	

SHEET NO. 1  
10 SHEETS

\* 81 (1-2, 1, 2-2) RS-1 & M

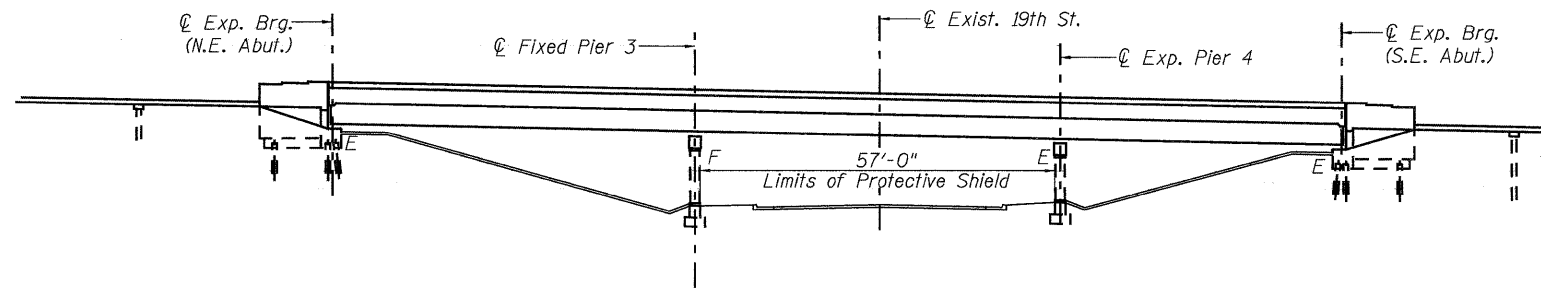

ELEVATION

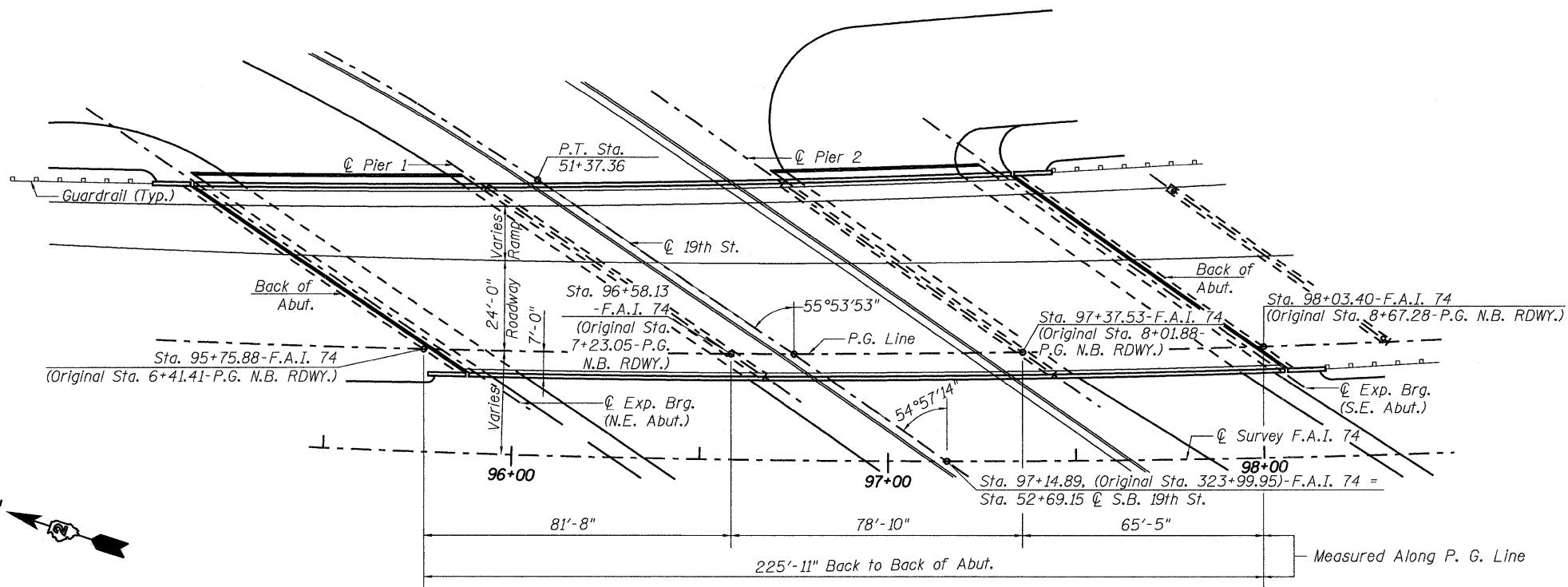

PLAN

GENERAL NOTES

No field welding is permitted except as specified in the contract documents.

Reinforcement bars shall conform to the requirements of ASTM A706 Grade 60. See Special Provisions.

Reinforcement bars designated (E) shall be epoxy coated.

Plan dimensions and details relative to existing plans are subject to routine variations. The Contractor shall field verify existing dimensions and details affecting new construction and make necessary approved adjustments prior to construction or ordering materials. Such variations shall not be cause for additional compensation for a change in scope of work, however, the Contractor will be paid for the quantity actually furnished at the unit price bid for work.

Exist. reinforcement bars extending into the removal areas shall be cleaned, straightened and incorporated into the new construction. Any reinforcement bars that are damaged during concrete removal shall be replaced with approval bar splicer or anchorage system. Cost included with Concrete Removal.

Prior to pouring the new concrete deck, all heavy or loose rust, loose mill scale, and all other loose, potentially detrimental foreign material shall be removed from the surfaces in contact with concrete. Tightly adhered paint may remain unless otherwise noted. Removal shall be accomplished by methods that will not damage the steel and the cost will be included in the pay item covering removal of the existing concrete.

As directed by the Engineer, existing construction accessories welded to the top flange of beams and girders shall be removed. The weld areas shall be ground flush and inspected for cracks using magnetic particle testing (MT) or dye penetrant testing (PT) by an individual acceptable to the Engineer. Any cracks that can not be removed by grinding 1/4 in. deep shall be identified and reported to the Bureau of Bridges and Structures for further disposition. The cost of removing welded accessories, grinding and inspecting weld areas and grinding cracks will be paid for according to Article 109.04 of the Standard Specifications.

The existing structural steel coating contains lead. The contractor shall take appropriate precautions to deal with the presence of lead on this project.

Quantities of Deck Slab Repair (Full Depth, Type I), Deck Slab Repair (Full Depth, Type II) and Deck Slab Repair (Partial) are approximated. Locations will be determined by the Resident Engineer following removal of the Concrete Deck Overlay. Actual repair locations shall be shown on the as-built plans. Contractor will be paid for the quantities furnished.

Joint openings shall be adjusted according to article 520.04 of the standard specifications when the deck is poured at an ambient temperature other than 50° F.

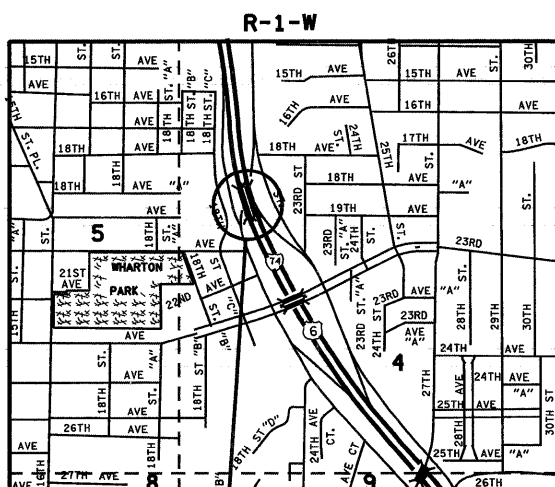

PROJECT LOCATION LOCATION PLAN

DESIGNED	DFM
CHECKED	DSG
DRAWN	EBS
CHECKED	DFM

*David F. Maxwell*  
David F. Maxwell, S.E. Reg. No. 081-005455  
Date: 9/10/08  
My registration expires November 30, 2010

TOTAL BILL OF MATERIAL

ITEM	UNIT	QUANTITY
Polymerized HMA Surface Course Mix "E", N70	TON	122
Concrete Removal	CU.YD.	29.9
Protective Shield	SQ.YD.	305
Concrete Superstructure	CU.YD.	29.9
Reinforcement Bars, Epoxy Coated	POUND	2720
Bar Splicers	EACH	22
Preformed Joint Strip Seal	FOOT	184
Waterproofing Membrane System	SQ.YD.	1170
Bridge Deck Scarification	SQ.YD.	1160
Deck Slab Repair (Full Depth Type I)	SQ.YD.	162.5
Deck Slab Repair (Full Depth Type II)	SQ.YD.	162.5
Deck Slab Repair (Partial)	SQ.YD.	120
Diamond Grinding (Bridge Section)	SQ.YD.	1170

PLAN AND ELEVATION  
F.A.I. 74 (OVER 19TH ST.)  
ROCK ISLAND COUNTY  
STRUCTURE NO. 081-0103

STATE OF ILLINOIS  
DEPARTMENT OF TRANSPORTATION

ROUTE NO.	SECTION	COUNTY	TOTAL SHEETS	SHEET NO.	SHEET NO. 2 10 SHEETS
FAI 74	*	ROCK ISLAND	246	169	
FED. ROAD DIST. NO. 7	ILLINOIS	FED. AID PROJECT-			

\* 81 (1-2, 1, 2-2) RS-1 & M

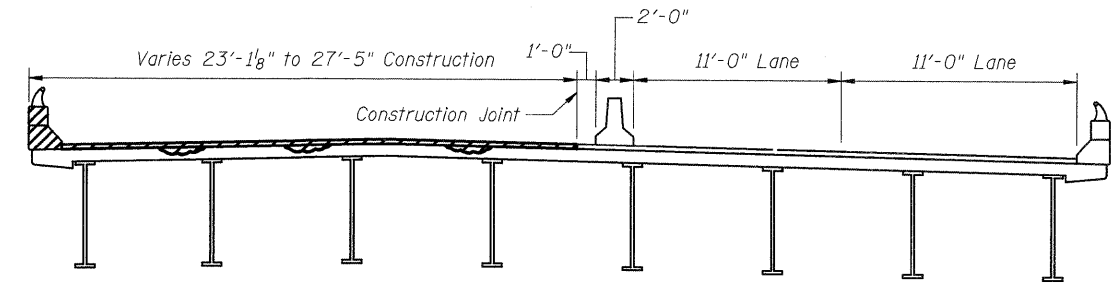
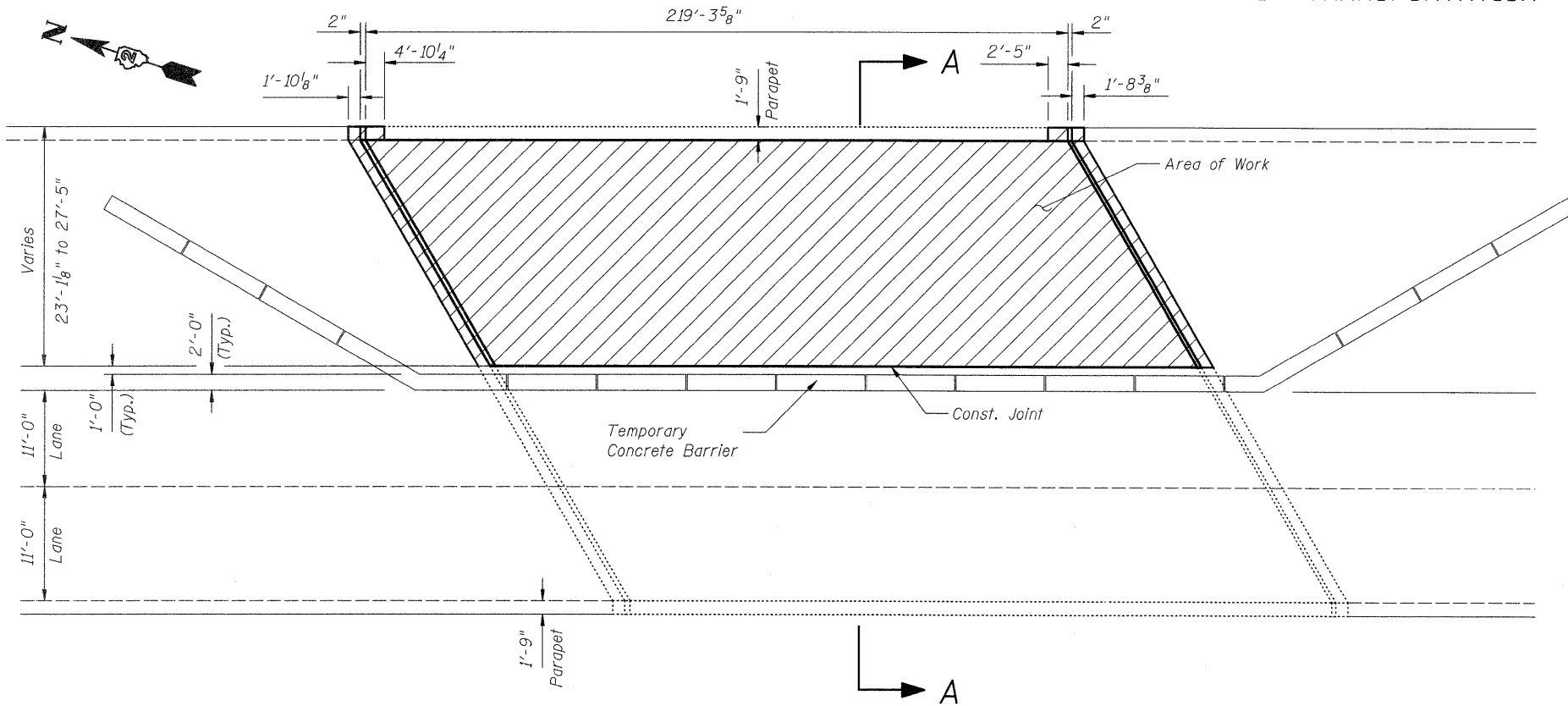

SECTION A-A

**STAGE I CONSTRUCTION**

- Install temporary concrete barrier as shown.\*
- Move traffic to Stage I traffic lanes.
- Sawcut concrete wearing surface and remove.
- Replace bridge joints and repair deck.
- Install new wearing surface & waterproofing membrane.
- \*For temporary concrete barrier details, see sheet 9 of 10.

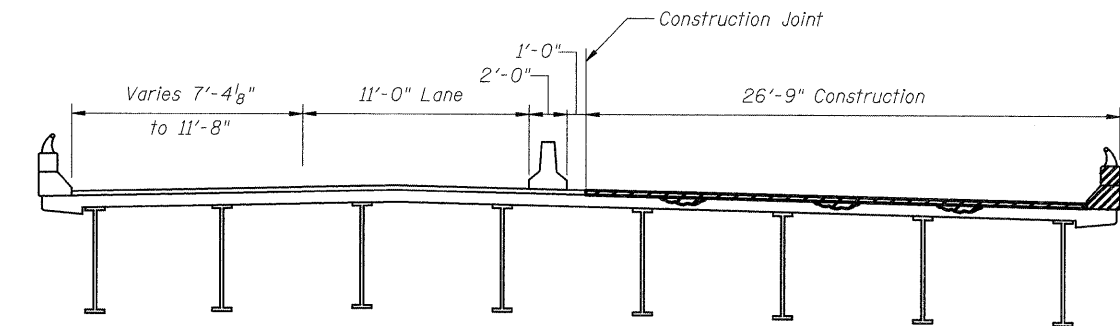
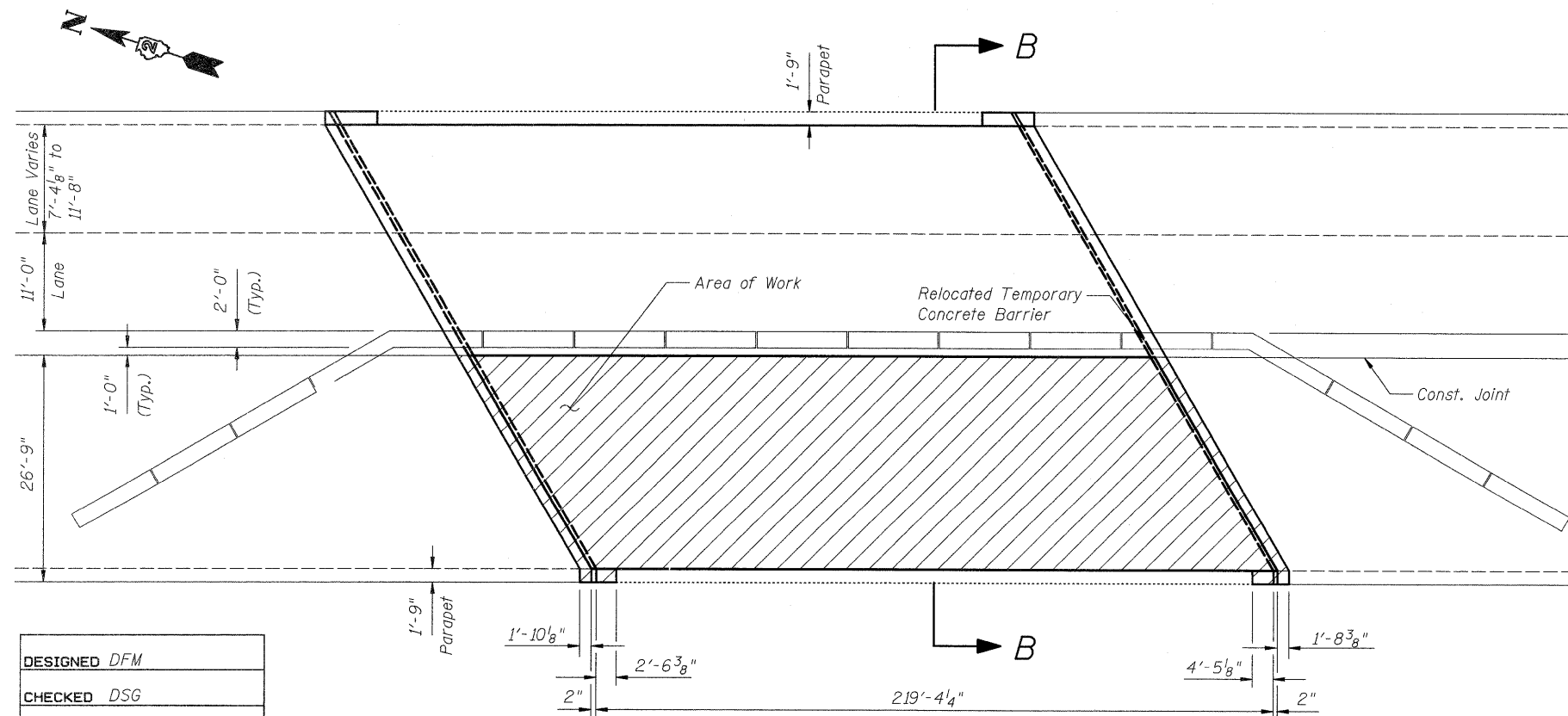

SECTION B-B

**STAGE II CONSTRUCTION**

- Relocate temporary concrete barrier as shown.\*
- Move traffic to Stage II traffic lanes.
- Remove concrete wearing surface.
- Replace bridge joints and repair deck.
- Install new wearing surface & waterproofing membrane.
- Remove temporary concrete barrier.

DESIGNED	DFM
CHECKED	DSG
DRAWN	EBS
CHECKED	DFM

**STAGING PLAN**  
**F.A.I. 74 (OVER 19TH ST.)**  
**ROCK ISLAND COUNTY**  
**STRUCTURE NO. 081-0103**

STATE OF ILLINOIS  
DEPARTMENT OF TRANSPORTATION

ROUTE NO.	SECTION	COUNTY	TOTAL SHEETS	SHEET NO.	SHEET NO. 3
FAI 74	*	ROCK ISLAND	246	170	10 SHEETS
FED. ROAD DIST. NO. 7	ILLINOIS	FED. AID PROJECT-			

\* 81 (1-2, 1, 2-2) RS-1 & M

**BILL OF MATERIAL**

ITEM	UNIT	QUANTITY
Polymerized HMA Surface Course Mix "E", N90	TON	122
Protective Shield	SQ.YD.	305
Waterproofing Membrane System	SQ.YD.	1170
Bridge Deck Scarification	SQ.YD.	1160

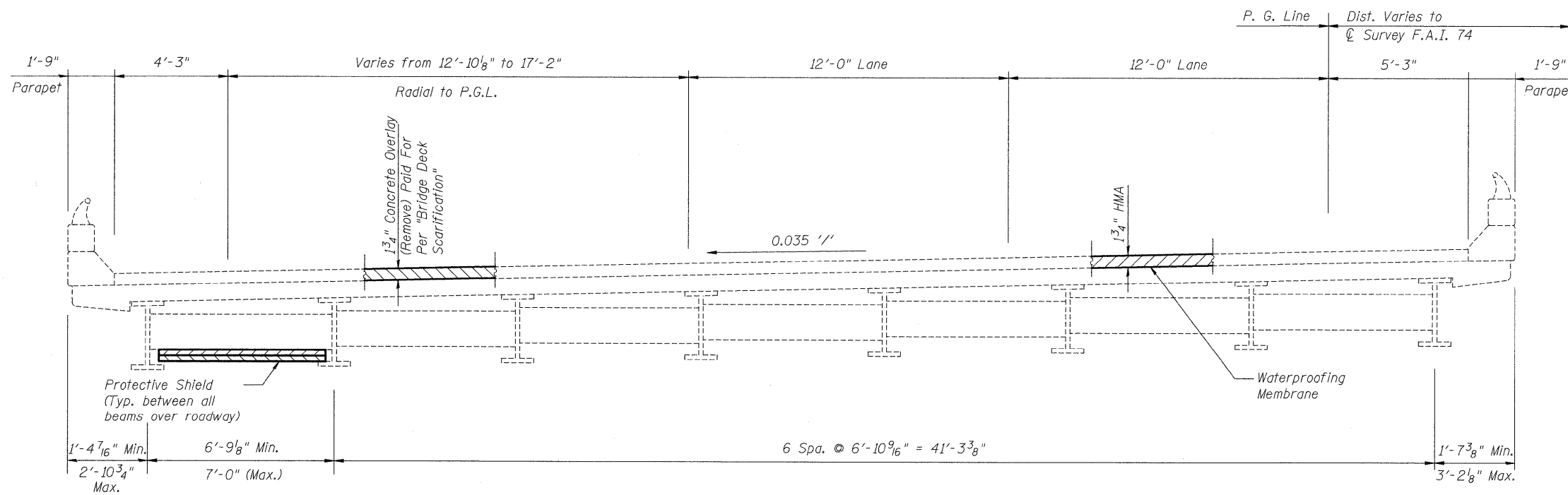

**CROSS SECTION**  
(Looking South)

DESIGNED	DFM
CHECKED	DFM
DRAWN	EBS
CHECKED	DFM

**BRIDGE REPAIR DETAILS**  
F.A.I. 74 (OVER 19TH ST.)  
ROCK ISLAND COUNTY  
STRUCTURE NO. 081-0103

STATE OF ILLINOIS  
DEPARTMENT OF TRANSPORTATION

ROUTE NO.	SECTION	COUNTY	TOTAL SHEETS	SHEET NO.	SHEET NO. 4 10 SHEETS
FAI 74	*	ROCK ISLAND	246	141	
FED. ROAD DIST. NO. 7	ILLINOIS	FED. AID PROJECT-			

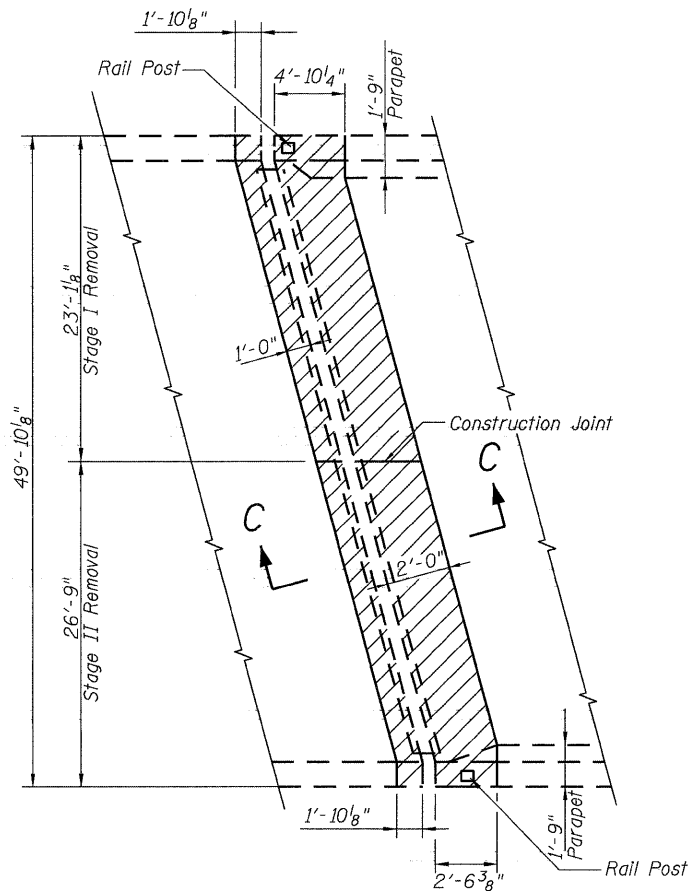

EXISTING PARTIAL PLAN - NORTH ABUTMENT

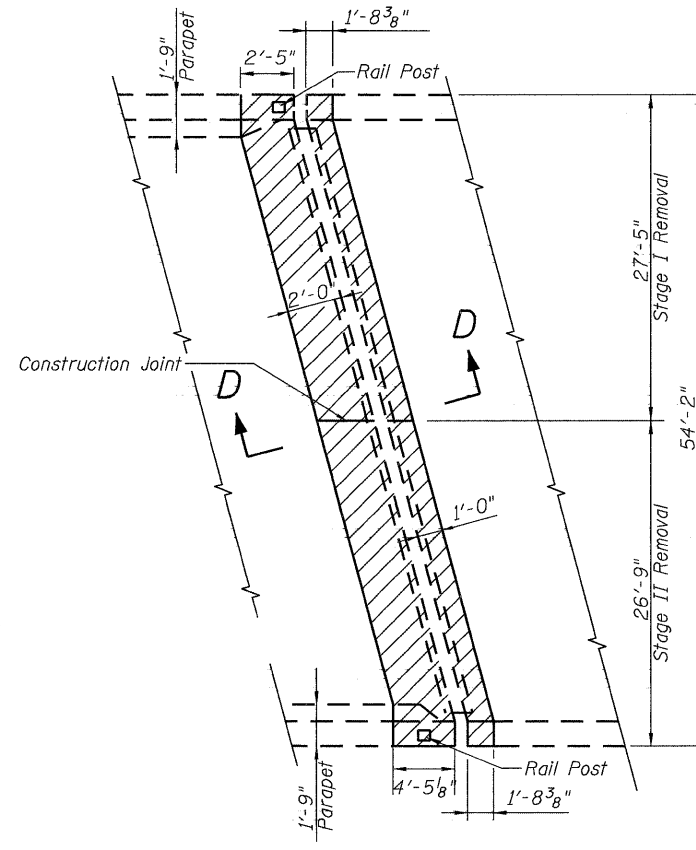

EXISTING PARTIAL PLAN - SOUTH ABUTMENT

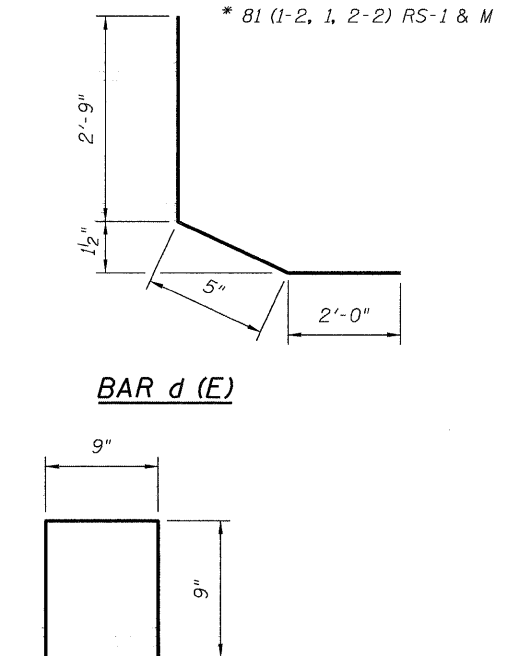
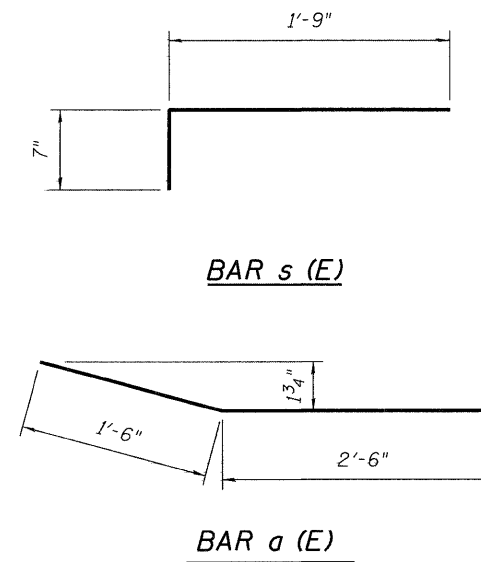

BAR d<sub>2</sub> (E)

BILL OF MATERIAL

BAR	NO.	SIZE	LENGTH	SHAPE
a (E)	16	#6	4'-0"	
a <sub>1</sub> (E)	8	#5	42'-2"	
a <sub>2</sub> (E)	8	#5	46'-3"	
a <sub>3</sub> (E)	3	#6	42'-2"	
a <sub>4</sub> (E)	3	#6	46'-3"	
a <sub>5</sub> (E)	8	#5	46'-0"	
a <sub>6</sub> (E)	8	#5	42'-6"	
a <sub>7</sub> (E)	3	#6	46'-0"	
a <sub>8</sub> (E)	3	#6	42'-5"	
d (E)	16	#4	4'-0"	└┘
d <sub>1</sub> (E)	16	#5	2'-9"	└┘
d <sub>2</sub> (E)	8	#4	2'-3"	└┘
s (E)	99	#5	2'-4"	└┘
Reinforcement Bars Epoxy Coated			Pound	2720
Concrete Removal			Cu. Yd.	29.9
Concrete Superstructure			Cu. Yd.	29.9
Bar Splicer			Each	22

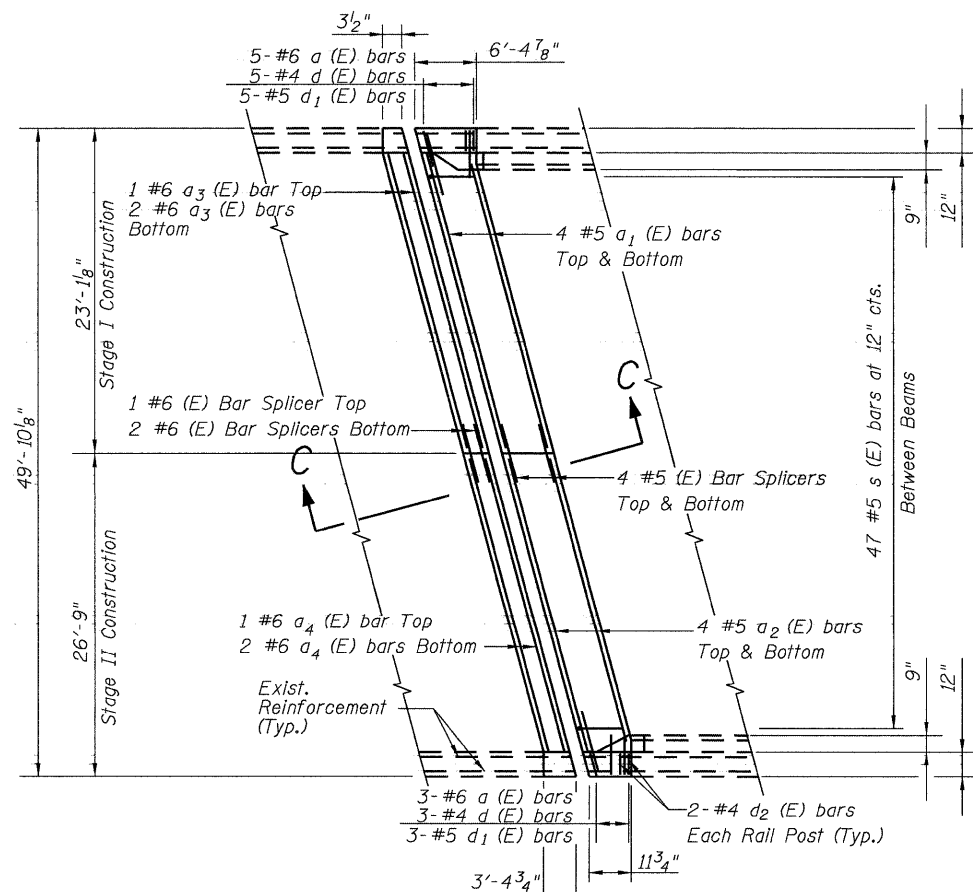

PROPOSED PARTIAL PLAN - NORTH ABUTMENT

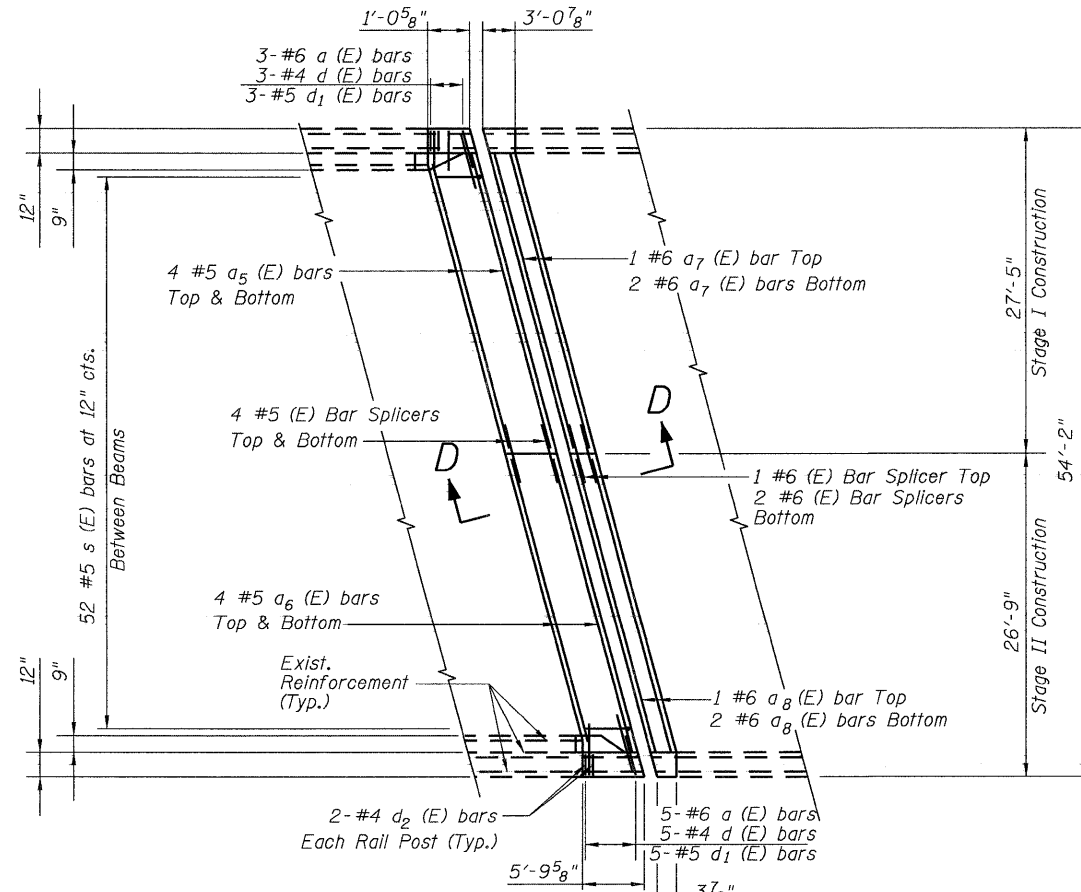

PROPOSED PARTIAL PLAN - SOUTH ABUTMENT

DESIGNED	DFM
CHECKED	DSG
DRAWN	EBS
CHECKED	DFM

For bar splicer assembly details see sheet 8 of 10.  
For Rail Post Details see sheet 10 of 10.  
For sections C-C and D-D see sheet 5 of 10.

LEGEND

- Concrete Removal
- Concrete Superstructure

JOINT RECONSTRUCTION DETAILS  
F.A.I. 74 (OVER 19TH ST.)  
ROCK ISLAND COUNTY  
STRUCTURE NO. 081-0103

STATE OF ILLINOIS  
DEPARTMENT OF TRANSPORTATION

ROUTE NO.	SECTION	COUNTY	TOTAL SHEETS	SHEET NO.	SHEET NO.
FAI 74	*	ROCK ISLAND	246	172	10 SHEETS
FED. ROAD DIST. NO. 7	ILLINOIS	FED. AID PROJECT-			

\* 81 (1-2, 1, 2-2) RS-1 & M

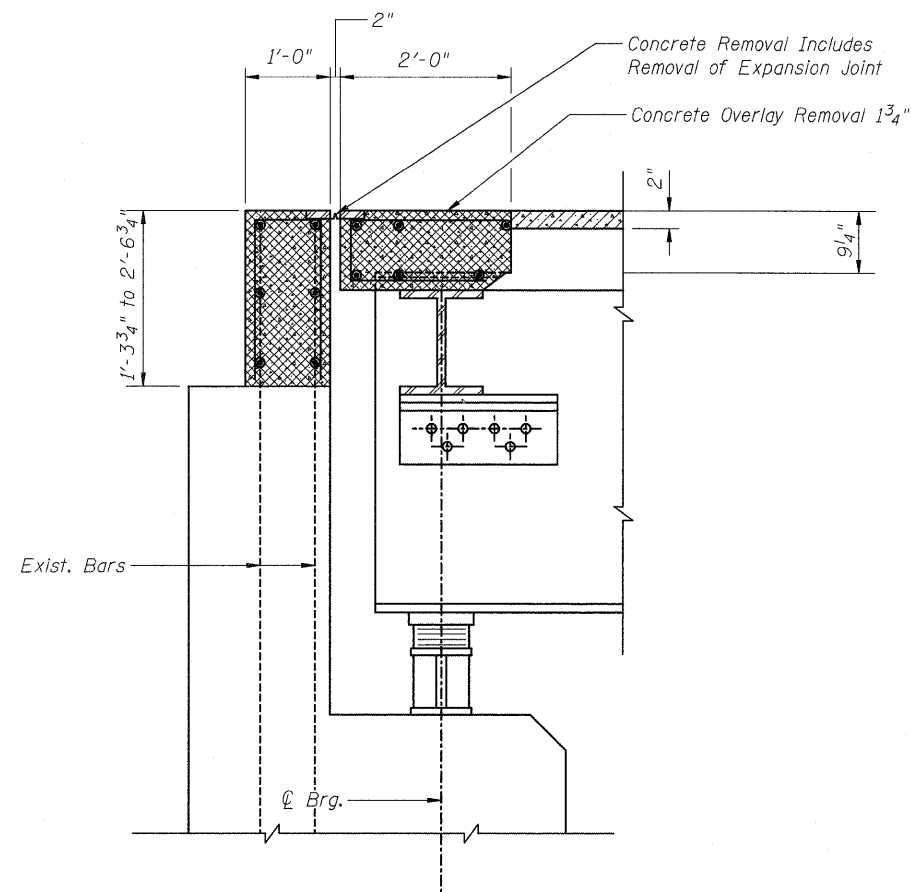

EXISTING SECTION C-C THRU NORTH ABUTMENT

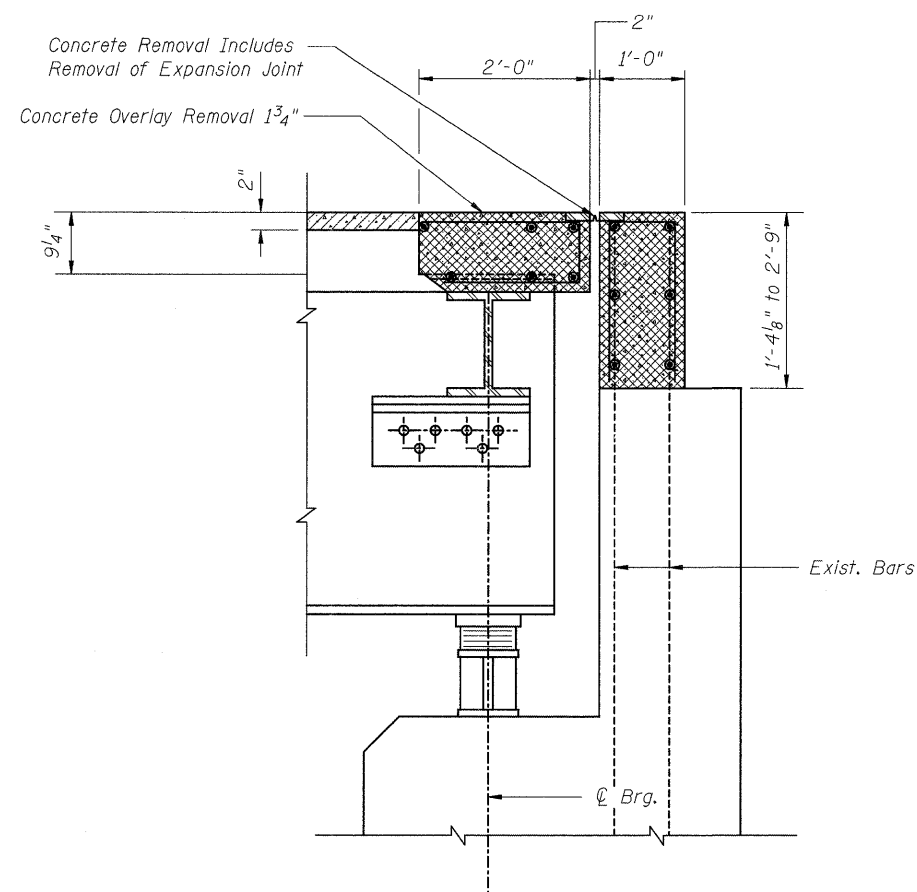

EXISTING SECTION D-D THRU SOUTH ABUTMENT

LEGEND

-  Concrete Removal
-  Bridge Deck Scarification

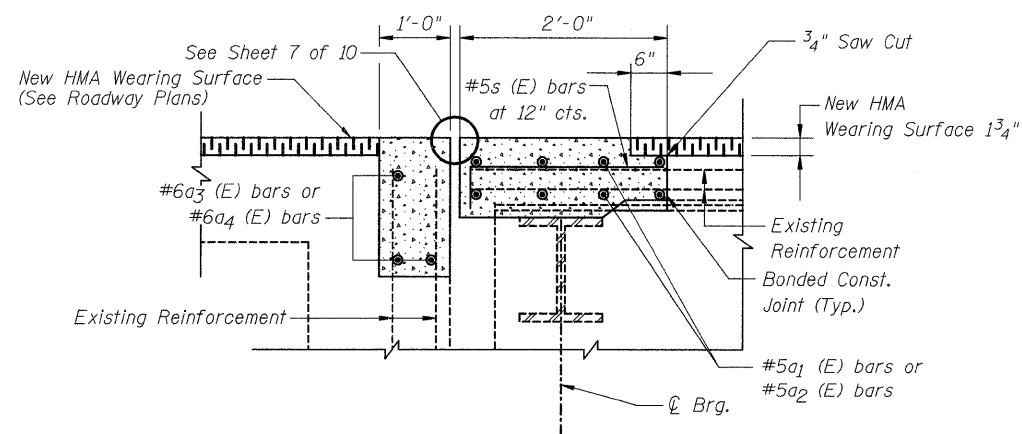

PROPOSED SECTION C-C THRU NORTH ABUTMENT

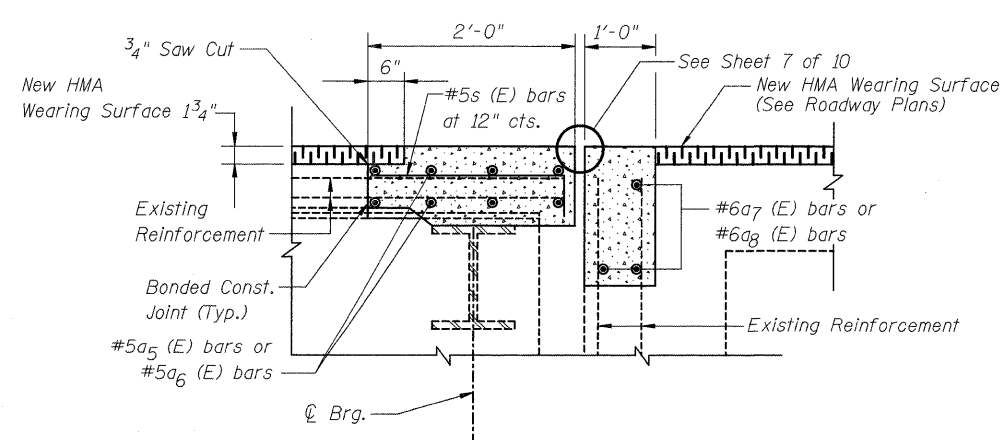

PROPOSED SECTION D-D THRU SOUTH ABUTMENT

DESIGNED	DFM
CHECKED	DFM
DRAWN	EBS
CHECKED	DFM

JOINT RECONSTRUCTION DETAILS  
F.A.I. 74 (OVER 19TH ST.)  
ROCK ISLAND COUNTY  
STRUCTURE NO. 081-0103



STATE OF ILLINOIS  
DEPARTMENT OF TRANSPORTATION

ROUTE NO.	SECTION	COUNTY	TOTAL SHEETS	SHEET NO.	SHEET NO. 6
FAI 74	*	ROCK ISLAND	246	173	10 SHEETS
FED. ROAD DIST. NO. 7	SLD#08	FED. AID PROJECT#			

\* 81 (1-2, 1, 2-2) RS-1 & M

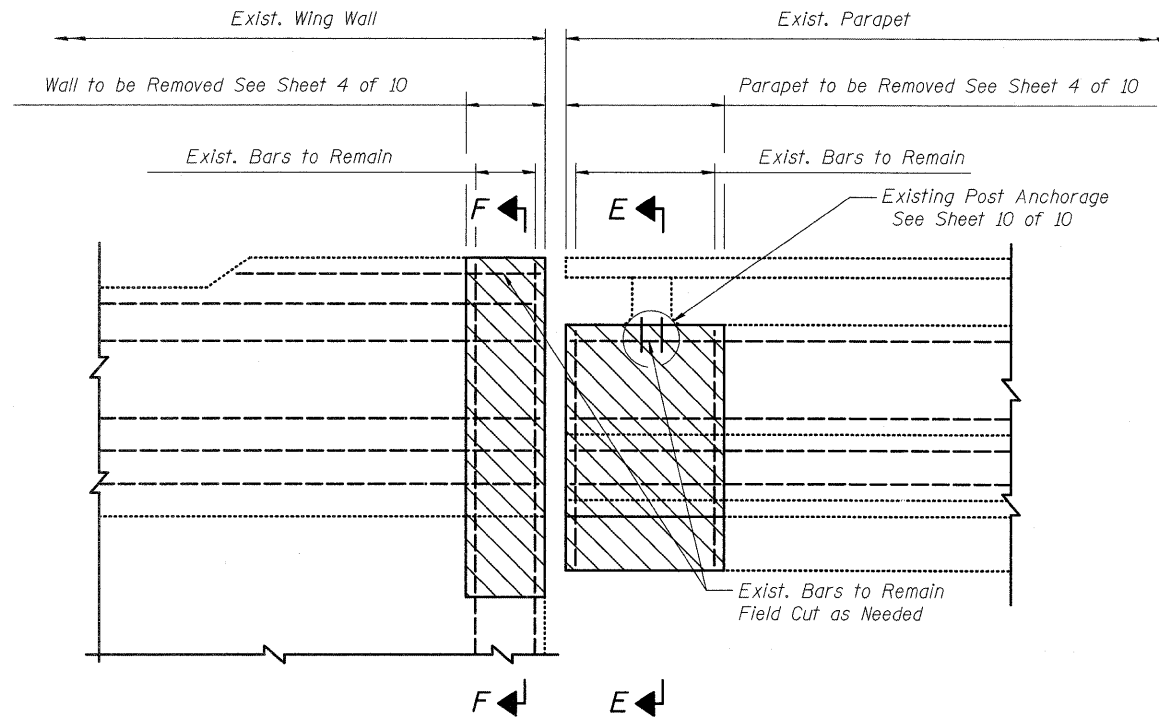

ELEVATION OF CONCRETE REMOVAL THRU PARAPET AND WING WALL

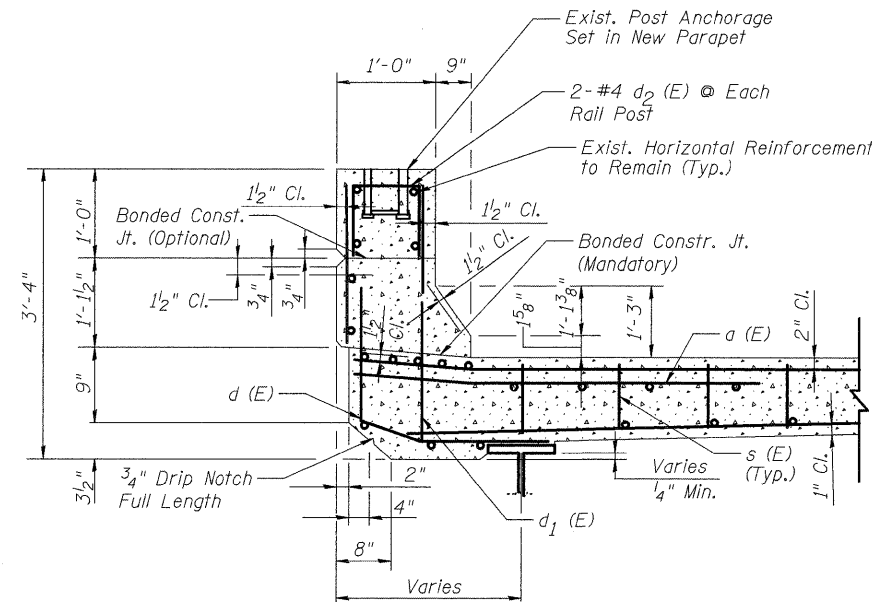

SECTION E-E THRU BRIDGE DECK PARAPET

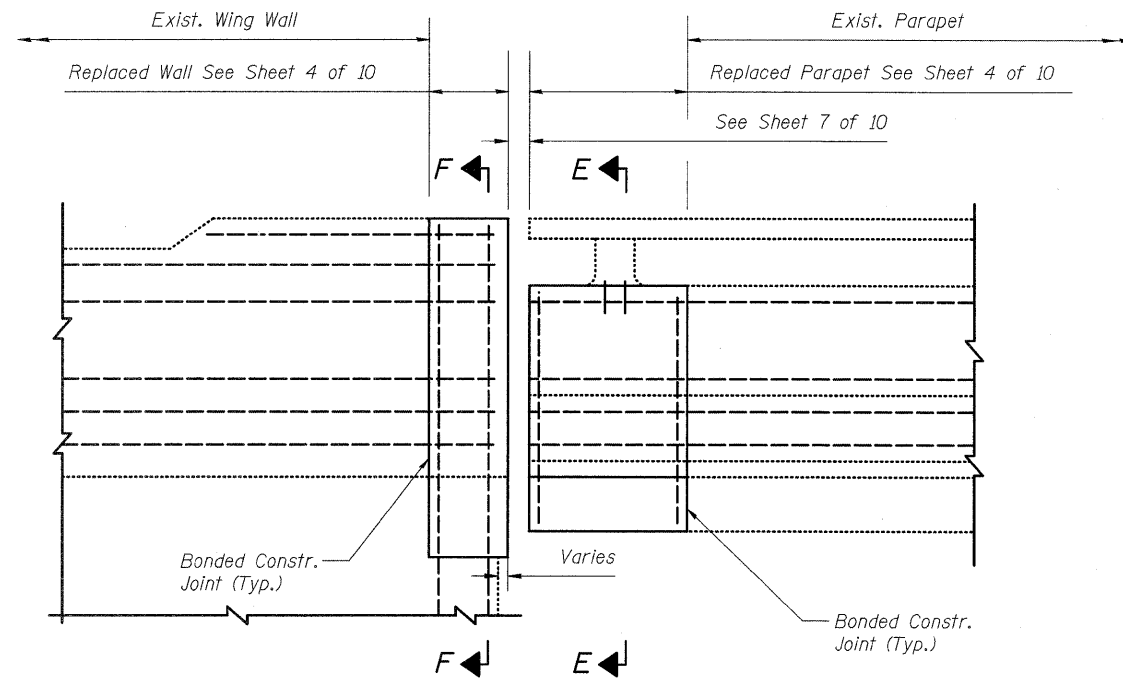

ELEVATION OF CONCRETE REPLACEMENT THRU PARAPET AND WING WALL

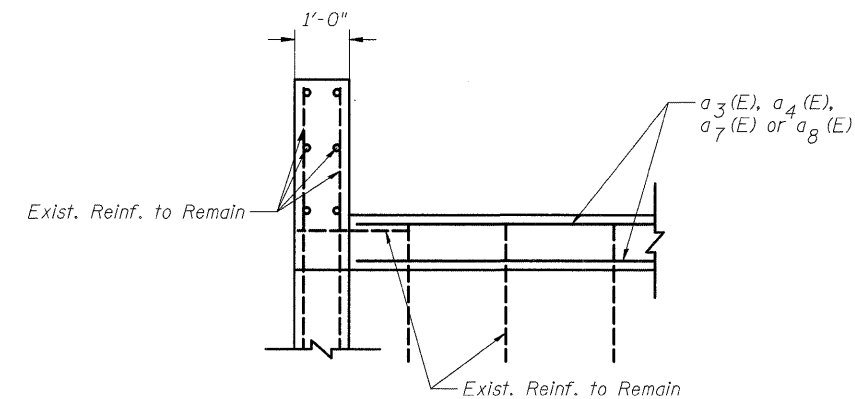

SECTION F-F THRU ABUTMENT BACKWALL AND WING WALL

DESIGNED	DFM
CHECKED	DSG
DRAWN	EBS
CHECKED	DFM

Note:

Hatched areas indicate concrete sections to be removed and replaced. Perimeters of concrete removal areas shall be saw cut 3/4" prior to the removal of concrete.

PARAPET AND RETAINING WALL DETAILS  
F.A.I. 74 (OVER 19TH ST.)  
ROCK ISLAND COUNTY  
STRUCTURE NO. 081-0103

STATE OF ILLINOIS  
DEPARTMENT OF TRANSPORTATION

ROUTE NO.	SECTION	COUNTY	TOTAL SHEETS	SHEET NO.	SHEET NO. 7
FAI 74	*	ROCK ISLAND	246	174	10 SHEETS
FED. ROAD DIST. NO. 7	ILLINOIS	FED. AID PROJECT			

\*Granular or solid flux filled headed studs conforming to Article 1006.32 of the Std. Specs., automatically end welded.

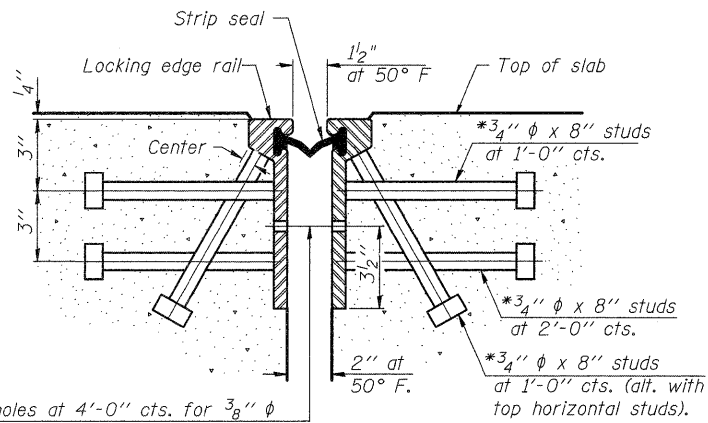

$\frac{7}{16}$ "  $\phi$  holes at 4'-0" cts. for  $\frac{3}{8}$ "  $\phi$  bolts. All bolts shall be burned, sawed, or chipped off flush with the plates after forms are removed, typ.

SECTION THRU ROLLED RAIL JOINT

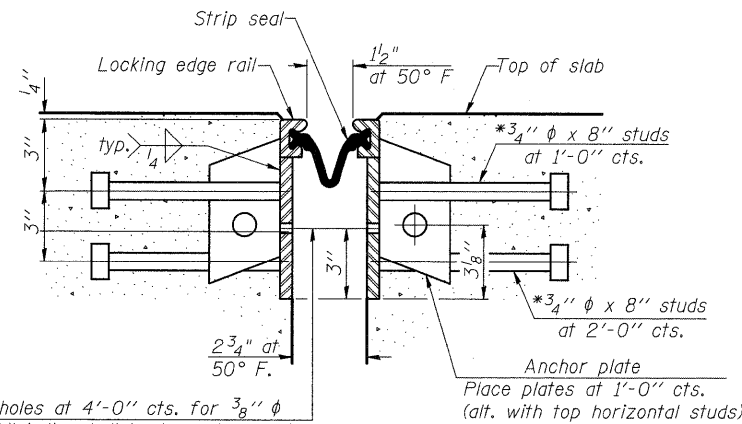

$\frac{7}{16}$ "  $\phi$  holes at 4'-0" cts. for  $\frac{3}{8}$ "  $\phi$  bolts. All bolts shall be burned, sawed, or chipped off flush with the plates after forms are removed, typ.

SECTION THRU WELDED RAIL JOINT

Notes:

The strip seal shall be made continuous and shall have a minimum thickness of  $\frac{1}{4}$ ". The configuration of the strip seal shall match the configuration of the Locking Edge Rails. Open or "webbed" strip seal gland configurations are not permitted. The gland shall be sized for a maximum rated movement of 4 inches.

The height and thickness of the Locking Edge Rails shown are minimum dimensions. The actual configuration of the Locking Edge Rails and matching strip seal may vary from manufacturer to manufacturer. Flanged edge rails will not be allowed. Locking Edge Rails may be spliced at slope discontinuities and stage construction joints.

The manufacturer's recommended installation methods shall be followed.

The joint opening and deck dimensions detailed on the superstructure are based on a rolled rail expansion joint. If the Contractor elects to use the welded rail expansion joint, the opening and deck dimensions shall be modified according to the dimensions detailed on this sheet. Required modifications shall be made at no additional cost to the State.

All steel components shall be galvanized after fabrication according to Article 520.03 of the Standard Specifications.

\* 81 (1-2, 1, 2-2) RS-1 & M

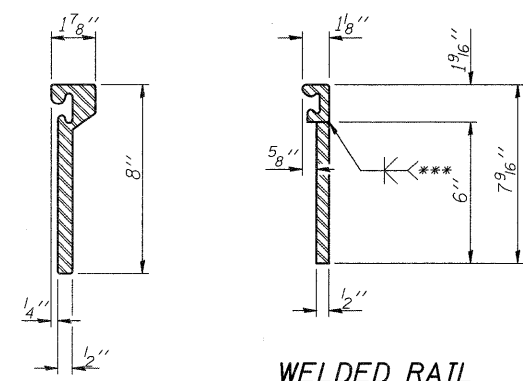

WELDED RAIL

\*\*\*Back gouge not required if complete joint penetration is verified by mock-up.

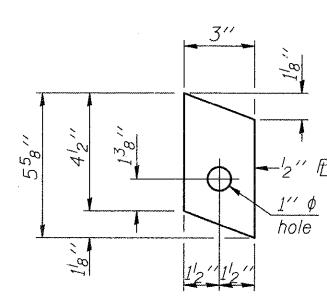

ANCHOR PLATE  
(for welded rail)

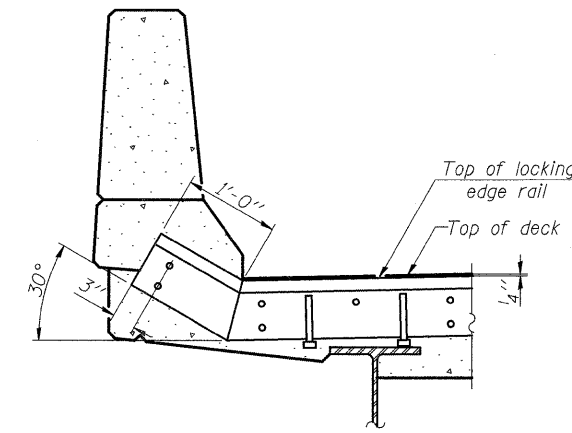

AT PARAPET

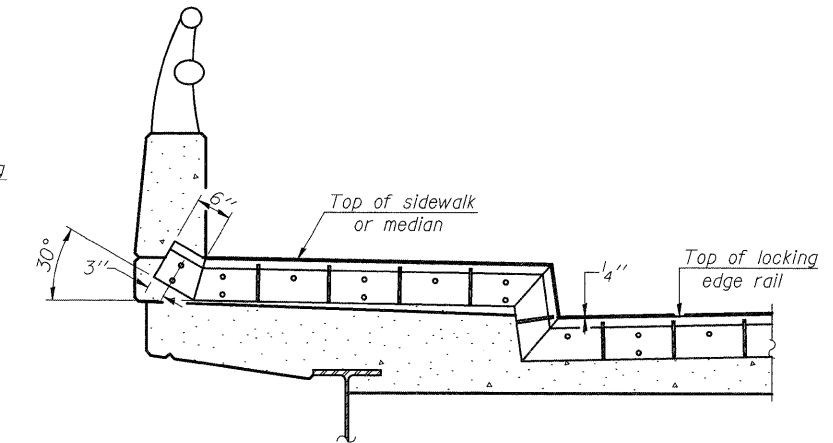

AT SIDEWALK OR MEDIAN

Shorter plates with a single row of studs at 12" cts. may be necessary on medians which are shallower than 9". See manufacturer's recommendation.

ROLLED EXTRUDED RAIL

LOCKING EDGE RAIL SPLICE

The inside of the locking edge rail groove shall be free of weld residue.

LOCKING EDGE RAILS

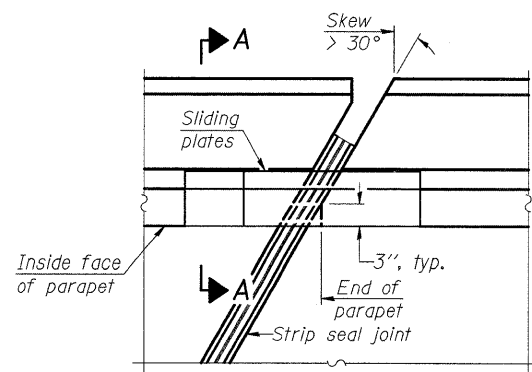

PLAN

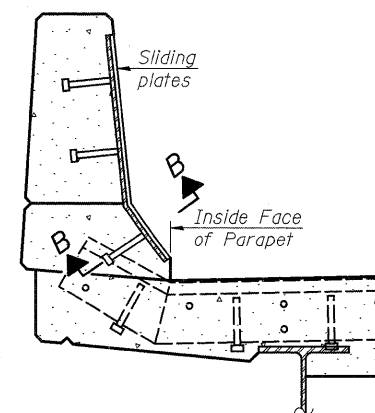

SECTION A-A

POINT BLOCK DETAILS  
(for skews > 30°)

TYPICAL END TREATMENTS

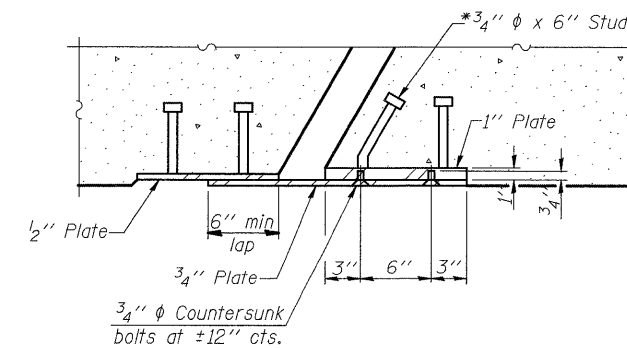

SECTION B-B

BILL OF MATERIAL

Item	Unit	Total
Preformed Joint Strip Seal	Foot	184

DESIGNED	DFM
CHECKED	DSG
DRAWN	EBS
CHECKED	DFM

EJ-SSJ 5-16-08

PREFORMED JOINT STRIP SEAL  
F.A.I. 74 (OVER 19TH ST.)  
ROCK ISLAND COUNTY  
STRUCTURE NO. 081-0103

STATE OF ILLINOIS  
DEPARTMENT OF TRANSPORTATION

ROUTE NO.	SECTION	COUNTY	TOTAL SHEETS	SHEET NO.	SHEET NO. 8
FAI 74	*	ROCK ISLAND	246	175	10 SHEETS
FED. ROAD DIST. NO. 7	ILLINOIS	FED. AID PROJECT-			

\* 81 (1-2, 1, 2-2) RS-1 & M

**NOTES**

Bar splicer assemblies shall be of an approved type and shall develop in tension at least 125 percent of the yield strength of the lapped reinforcement bars.  
Splicer rods shall be of minimum 60 ksi yield strength, threaded or coiled full length.  
All reinforcement bars shall be lapped and tied to the splicer rods or dowel bars.  
Bar splicer assemblies shall be epoxy coated according to the requirements for reinforcement bars.  
Other systems of similar design may be submitted to the Engineer for approval. Approval shall be based on certified test results from an approved testing laboratory that the proposed bar splicer assembly satisfies the following requirements:

- ① Minimum Capacity =  $1.25 \times f_y \times A_t$   
(Tension in kips)
  - ② Minimum \*Pull-out Strength =  $0.66 \times f_y \times A_t$   
(Tension in kips)
- Where  $f_y$  = Yield strength of lapped reinforcement bars in ksi.  
 $A_t$  = Tensile stress area of lapped reinforcement bars.  
\* = 28 day concrete

**BAR SPLICER ASSEMBLIES**

Bar Size to be Spliced	Splicer Rod or Dowel Bar Length	Strength Requirements	
		Min. Capacity kips - tension	Min. Pull-Out Strength kips - tension
#4	1'-8"	14.7	7.9
#5	2'-0"	23.0	12.3
#6	2'-7"	33.1	17.4
#7	3'-5"	45.1	23.8
#8	4'-6"	58.9	31.3
#9	5'-9"	75.0	39.6
#10	7'-3"	95.0	50.3
#11	9'-0"	117.4	61.8

The diameter of this part is equal or larger than the diameter of bar spliced.

The diameter of this part is the same as the diameter of the bar spliced.

**ROLLED THREAD DOWEL BAR**



\*\* ONE PIECE

Wire Connector

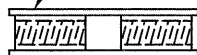

**WELDED SECTIONS**

**BAR SPLICER ASSEMBLY ALTERNATIVES**

\*\*Heavy Hex Nuts conforming to ASTM A 563, Grade C, D or DH may be used.

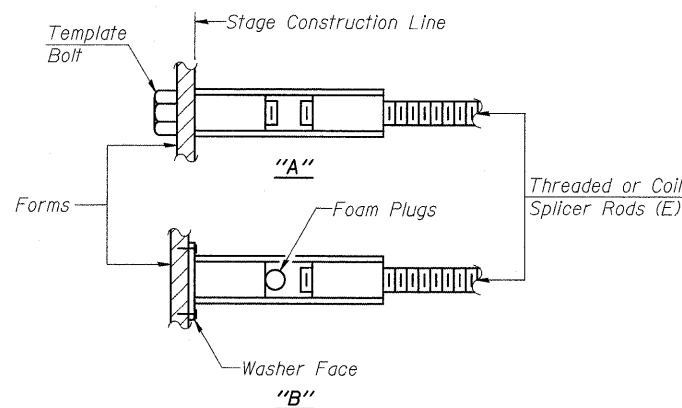

**INSTALLATION AND SETTING METHODS**

"A" :Set bar splicer assembly by means of a template bolt.  
"B" :Set bar splicer assembly by nailing to wood forms or cementing to steel forms.  
(E) : Indicates epoxy coating.

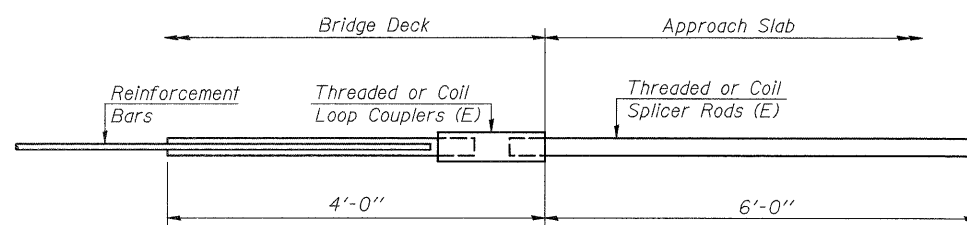

**FOR INTEGRAL OR SEMI-INTEGRAL ABUTMENTS**

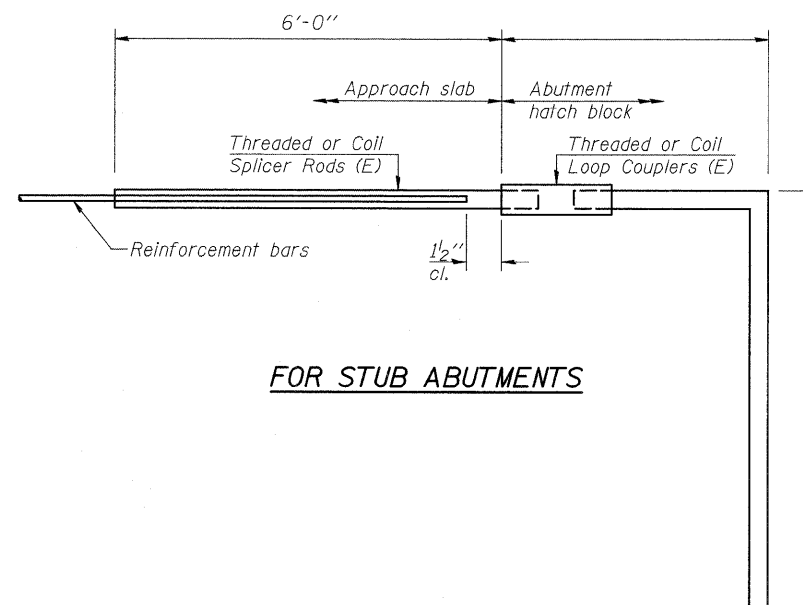

**FOR STUB ABUTMENTS**

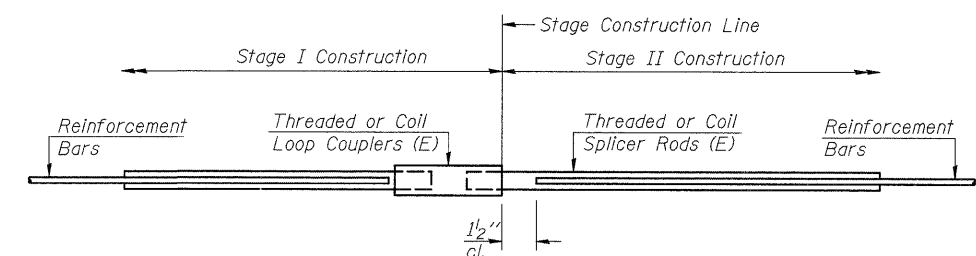

**STANDARD**

Bar Splicer for #5 bar
Min. Capacity = 23.0 kips - tension
Min. Pull-out Strength = 12.3 kips - tension
No. Required =

Bar Splicer for #5 bar
Min. Capacity = 23.0 kips - tension
Min. Pull-out Strength = 12.3 kips - tension
No. Required =

Bar Size	No. Assemblies Required	Location
#5	8	Bridge Deck at South Abutment
#5	8	Bridge Deck at North Abutment
#6	3	South Abutment Backwall
#6	3	North Abutment Backwall

DESIGNED DFM
CHECKED DSG
DRAWN EBS
CHECKED DFM

BSD-1

5-16-08

**BAR SPLICER ASSEMBLY DETAILS**  
**F.A.I. 74 (OVER 19TH ST.)**  
**ROCK ISLAND COUNTY**  
**STRUCTURE NO. 081-0103**

STATE OF ILLINOIS  
DEPARTMENT OF TRANSPORTATION

ROUTE NO.	SECTION	COUNTY	TOTAL SHEETS	SHEET NO.	SHEET NO. 9
FAI 74	*	ROCK ISLAND	246	176	10 SHEETS
FED. ROAD DIST. NO. 7	ILLINOIS	FED. AID PROJECT-			

\* 81 (1-2, 1, 2-2) RS-1 & M

When "A" is 3'-6" or less, the temporary concrete barrier shall be anchored to the new slab according to Detail I or Detail II. No anchorage is required when "A" is greater than 3'-6".

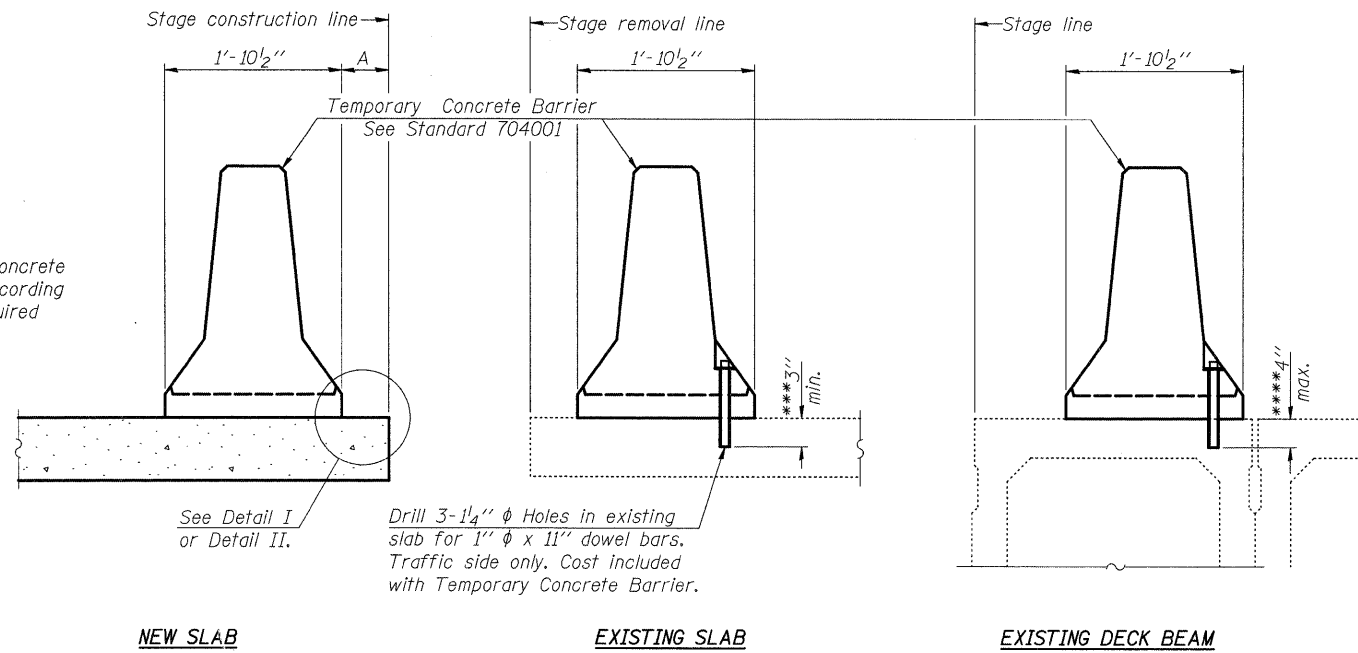

NEW SLAB

EXISTING SLAB

EXISTING DECK BEAM

SECTIONS THRU SLAB OR DECK BEAM

NOTES

Detail I - With Bar Splicer or Couplers:  
Connect one (1) 1"x7"x10" steel PL to the top layer of couplers with 2-5/8" φ bolts screwed to coupler at approximate C of each barrier panel.

Detail II - With Extended Reinforcement Bars:  
Connect one (1) 1"x7"x10" steel PL to the concrete slab or concrete wearing surface with 2-5/8" φ Expansion Anchors or cast in place inserts spaced between the top layer of reinforcement at approximate C of each barrier panel.

Cost of anchorage is included with Temporary Concrete Barrier. The 1" x 7" x 10" plate shall not be removed until stage II construction forms and all reinforcement bars are in place and the concrete is ready to be placed.

\*\*\*Dimension shown is minimum required embedment into concrete. If hot-mix asphalt wearing surface is present, minimum embedment shall be in addition to wearing surface depth.

\*\*\*\*If existing deck beam is to remain in place after stage construction, embedment shall only be into wearing surface and not into existing deck beam concrete.

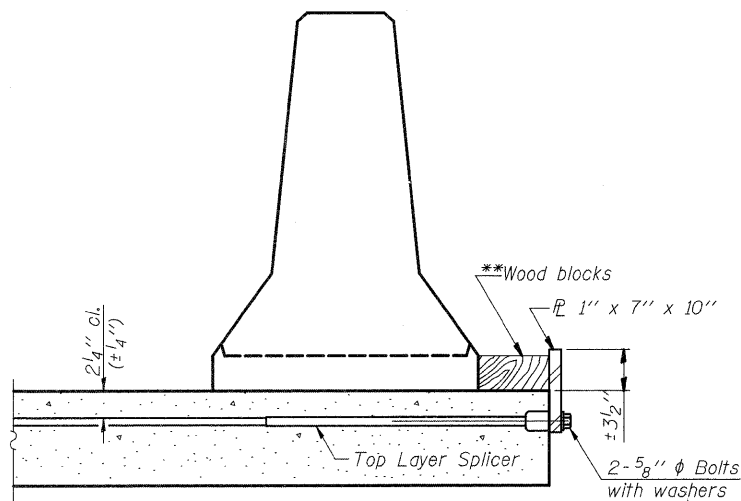

DETAIL I

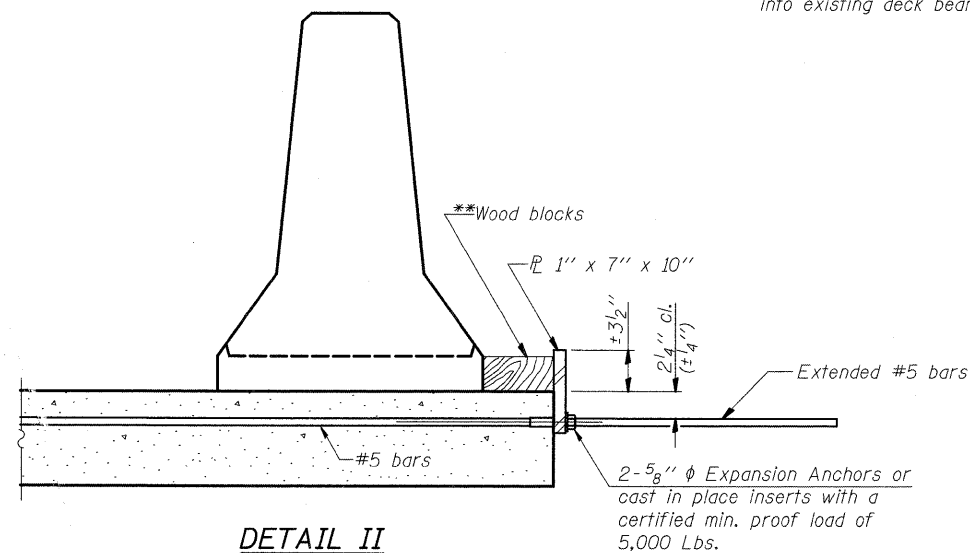

DETAIL II

\*\*Wood blocks may be omitted when required to provide minimum stage traffic lane width. When the wood blocks are omitted, the concrete barrier shall be in direct contact with the steel retainer plate.

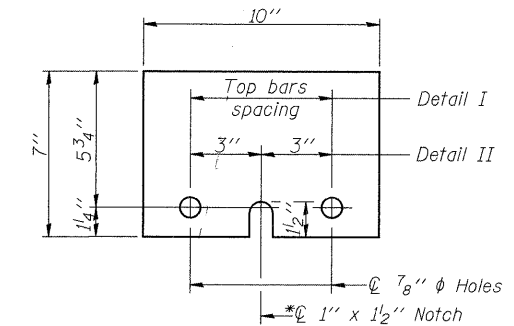

STEEL RETAINER PL 1" x 7" x 10"

\*Required only with Detail II

DESIGNED	DFM
CHECKED	DSG
DRAWN	EBS
CHECKED	DFM

R-27

5-16-08

TEMPORARY CONCRETE BARRIER  
FOR STAGE CONSTRUCTION  
F.A.I. 74 (OVER 19TH ST.)  
ROCK ISLAND COUNTY  
STRUCTURE NO. 081-0103

STATE OF ILLINOIS  
DEPARTMENT OF TRANSPORTATION

ROUTE NO.	SECTION	COUNTY	TOTAL SHEETS	SHEET NO.
FAT 74	#	ROCK ISLAND	246	177
FED. ROAD DIST. NO. 7		ILLINOIS	FED. AID PROJECT-	

SHEET NO. 10

10 SHEETS

\* 81 (1-2, 1, 2-2) RS-1 & M

NOTE:

Seal perimeter of post to parapet with two component non-staining gray sealing compound with polysulfide liquid polymers-gun grade with primer.

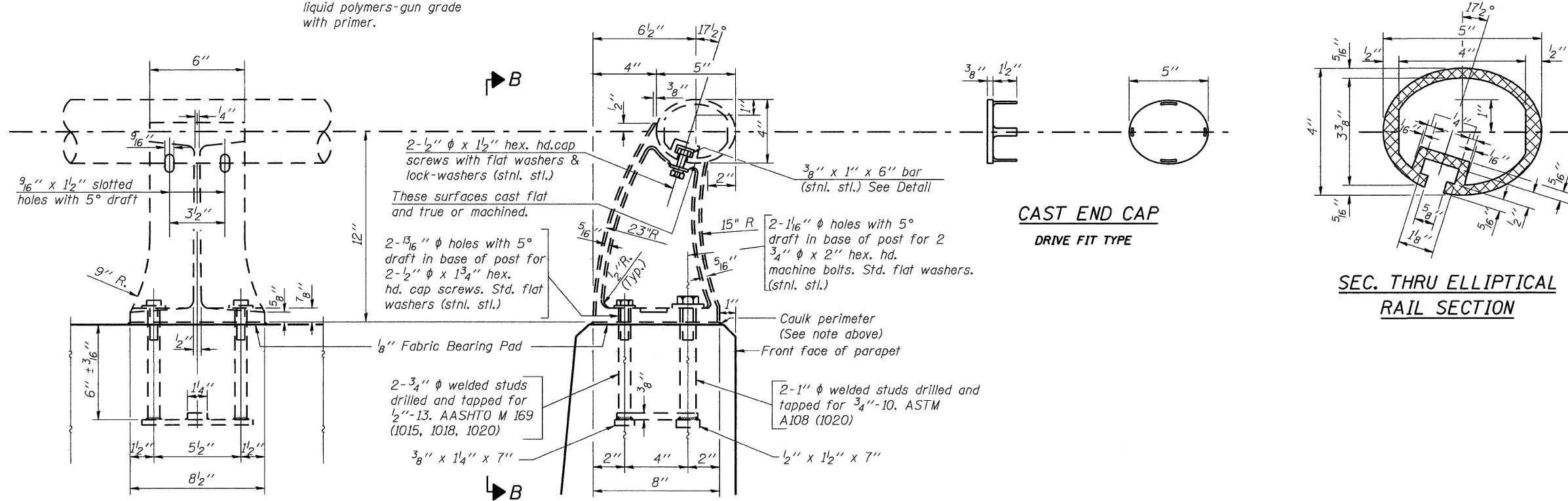

VIEW B-B

SECTION A-A

RAIL POST DETAILS

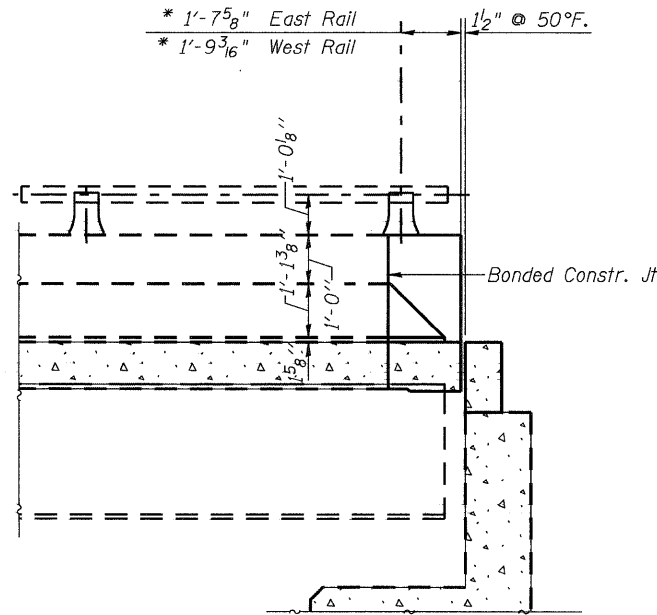
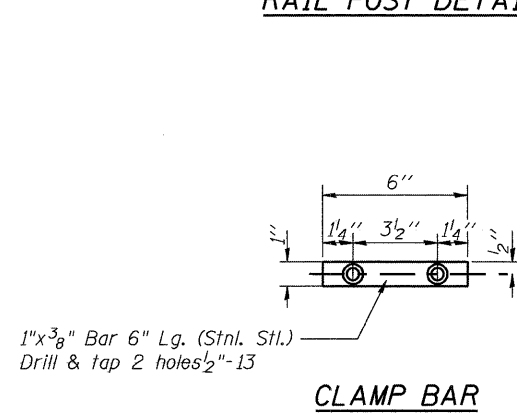

INSIDE VIEW AT PROPOSED ABUTMENTS

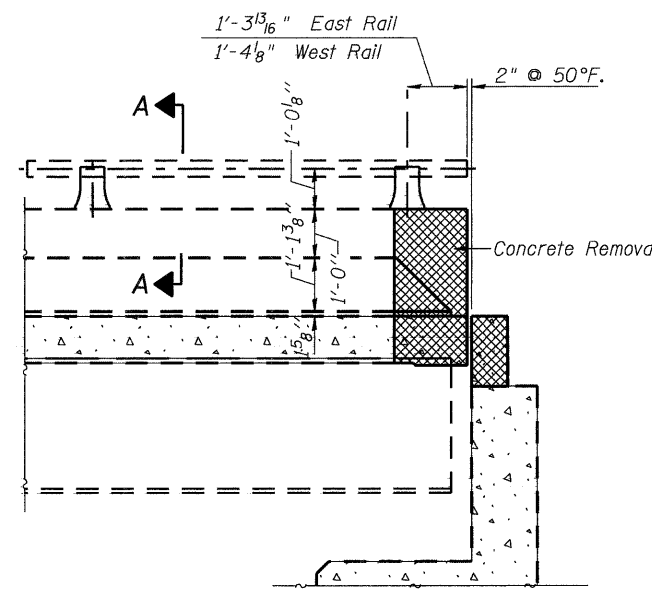

INSIDE VIEW AT EXISTING ABUTMENTS

Notes:

For concrete removal limits See Sheet 4 of 10.

Remove and reuse railing, including posts and anchors, where concrete removal affects existing rail posts. Cost included with Concrete Superstructure. If anchors are damaged during construction, they shall be replaced and are included with Concrete Removal.

\* Actual distance varies. New Joints are skewed through Parapet. Length of rail shall be adjusted as necessary with a flush cut and the cast end cap shall be reused.

DESIGNED	DFM
CHECKED	DSG
DRAWN	EBS
CHECKED	DFM

RAILING DETAILS  
F.A.I. 74 (OVER 19TH ST.)  
ROCK ISLAND COUNTY  
STRUCTURE NO. 081-0103

STATE OF ILLINOIS  
DEPARTMENT OF TRANSPORTATION

ROUTE NO.	SECTION	COUNTY	TOTAL SHEETS	SHEET NO.	SHEET NO. 1
FAI 74	*	ROCK ISLAND	246	178	10 SHEETS
FED. ROAD DIST. NO. 7	ILLINOIS	FED. AID PROJECT-			

\* 81 (1-2, 1, 2-2) RS-1 & M

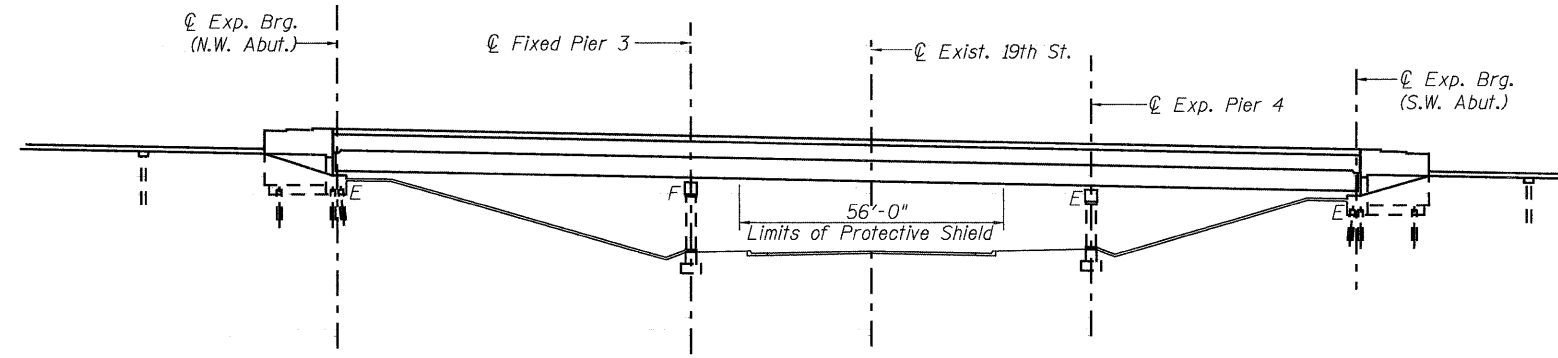

ELEVATION

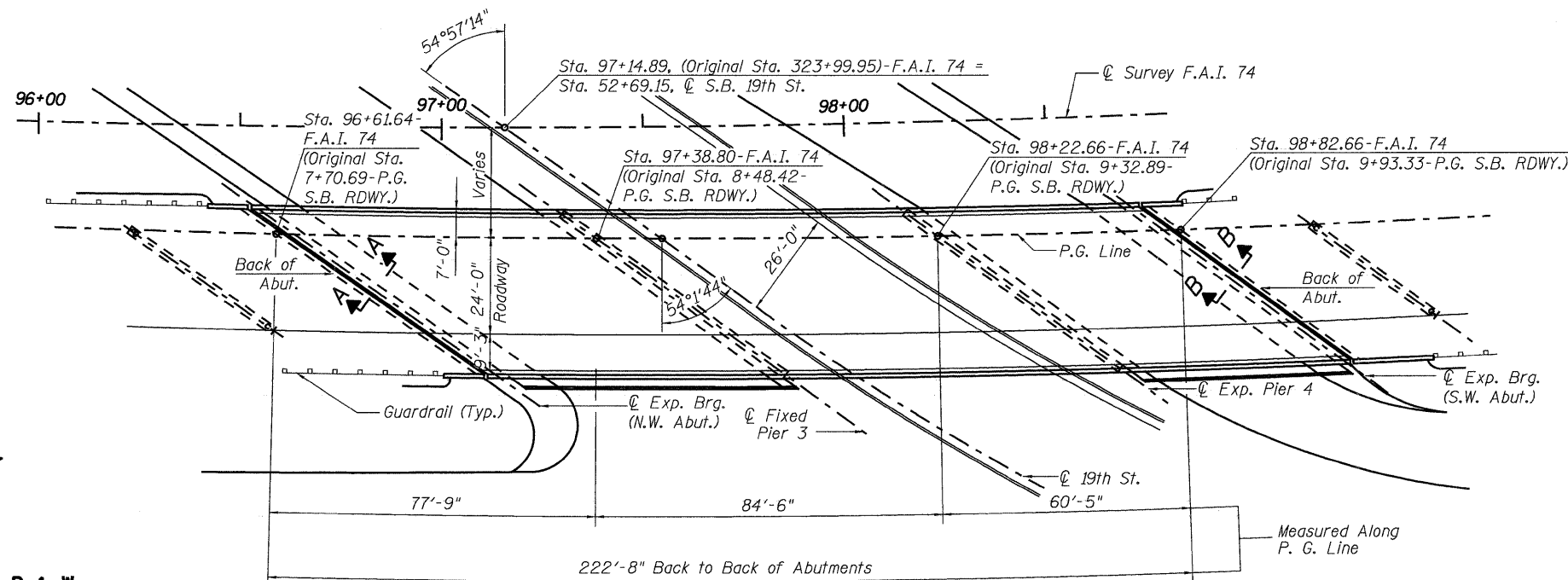

PLAN

GENERAL NOTES

No field welding is permitted except as specified in the contract documents.

Reinforcement bars shall conform to the requirements of ASTM A706 Grade 60. See Special Provisions.

Reinforcement bars designated (E) shall be epoxy coated.

Plan dimensions and details relative to existing plans are subject to routine variations. The Contractor shall field verify existing dimensions and details affecting new construction and make necessary approved adjustments prior to construction or ordering materials. Such variations shall not be cause for additional compensation for a change in scope of work, however, the Contractor will be paid for the quantity actually furnished at the unit price bid for work.

Exist. reinforcement bars extending into the removal areas shall be cleaned, straightened and incorporated into the new construction. Any reinforcement bars that are damaged during concrete removal shall be replaced with approval bar splicer or anchorage system. Cost included with Concrete Removal.

Prior to pouring the new concrete deck, all heavy or loose rust, loose mill scale, and all other loose, potentially detrimental foreign material shall be removed from the surfaces in contact with concrete. Tightly adhered paint may remain unless otherwise noted. Removal shall be accomplished by methods that will not damage the steel and the cost will be included in the pay item covering removal of the existing concrete.

As directed by the Engineer, existing construction accessories welded to the top flange of beams and girders shall be removed. The weld areas shall be ground flush and inspected for cracks using magnetic particle testing (MT) or dye penetrant testing (PT) by an individual acceptable to the Engineer. Any cracks that can not be removed by grinding 1/4 in. deep shall be identified and reported to the Bureau of Bridges and Structures for further disposition. The cost of removing welded accessories, grinding and inspecting weld areas and grinding cracks will be paid for according to Article 109.04 of the Standard Specifications.

The existing structural steel coating contains lead. The contractor shall take appropriate precautions to deal with the presence of lead on this project.

Quantities of Deck Slab Repair (Full Depth, Type I), Deck Slab Repair (Full Depth, Type II) and Deck Slab Repair (Partial) are approximated. Locations will be determined by the Resident Engineer following removal of the Concrete Deck Overlay. Actual repair locations shall be shown on the as-built plans. Contractor will be paid for the quantities furnished.

Joint openings shall be adjusted according to article 520.04 of the standard specifications when the deck is poured at an ambient temperature other than 50° F.

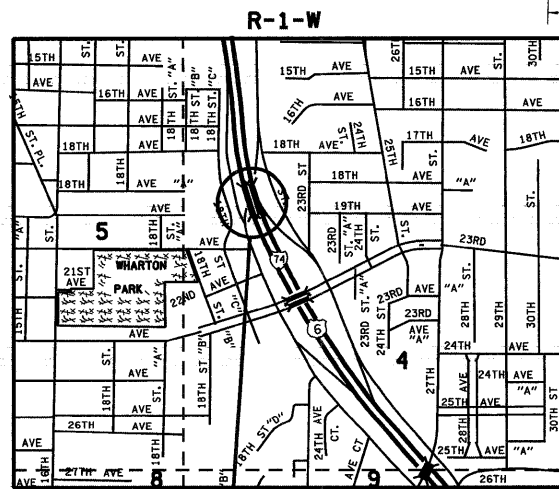

PROJECT LOCATION  
LOCATION PLAN

DESIGNED	DFM
CHECKED	DSG
DRAWN	EBS
CHECKED	DFM

STATE OF ILLINOIS  
DAVID  
F. MAXWELL  
081-005455  
ST. LOUIS, MO.  
LICENSED STRUCTURAL ENGINEER

*David F. Maxwell*  
David F. Maxwell, S.E. Reg. No. 081-005455  
Date: 9/10/08  
My registration expires November 30, 2010

TOTAL BILL OF MATERIAL

ITEM	UNIT	QUANTITY
Polymerized HMA Surface Course Mix "E", N70	TON	96
Concrete Removal	CU. YD.	21.8
Protective Shield	SQ. YD.	232
Concrete Superstructure	CU. YD.	21.8
Reinforcement Bars, Epoxy Coated	POUND	2100
Bar Splicers	EACH	22
Preformed Joint Strip Seal	FOOT	139
Waterproofing Membrane System	SQ. YD.	924
Bridge Deck Scarification	SQ. YD.	917
Deck Slab Repair (Full Depth Type I)	SQ. YD.	25
Deck Slab Repair (Full Depth Type II)	SQ. YD.	25
Deck Slab Repair (Partial)	SQ. YD.	120
Diamond Grinding (Bridge Section)	SQ. YD.	924

PLAN AND ELEVATION  
F.A.I. 74 (OVER 19TH ST.)  
ROCK ISLAND COUNTY  
STRUCTURE NO. 081-0104

STATE OF ILLINOIS  
DEPARTMENT OF TRANSPORTATION

ROUTE NO.	SECTION	COUNTY	TOTAL SHEETS	SHEET NO.
FAI 74	*	ROCK ISLAND	246	179
FED. ROAD DIST. NO. 7	ILLINOIS	FED. AID PROJECT-		

SHEET NO. 2  
10 SHEETS

\* 81 (1-2, 1, 2-2) RS-1 & M

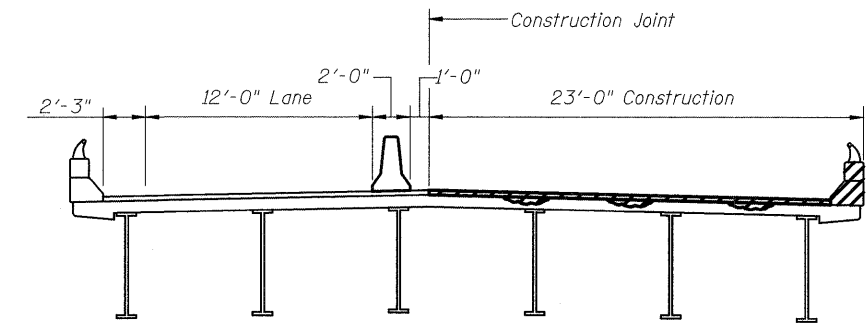
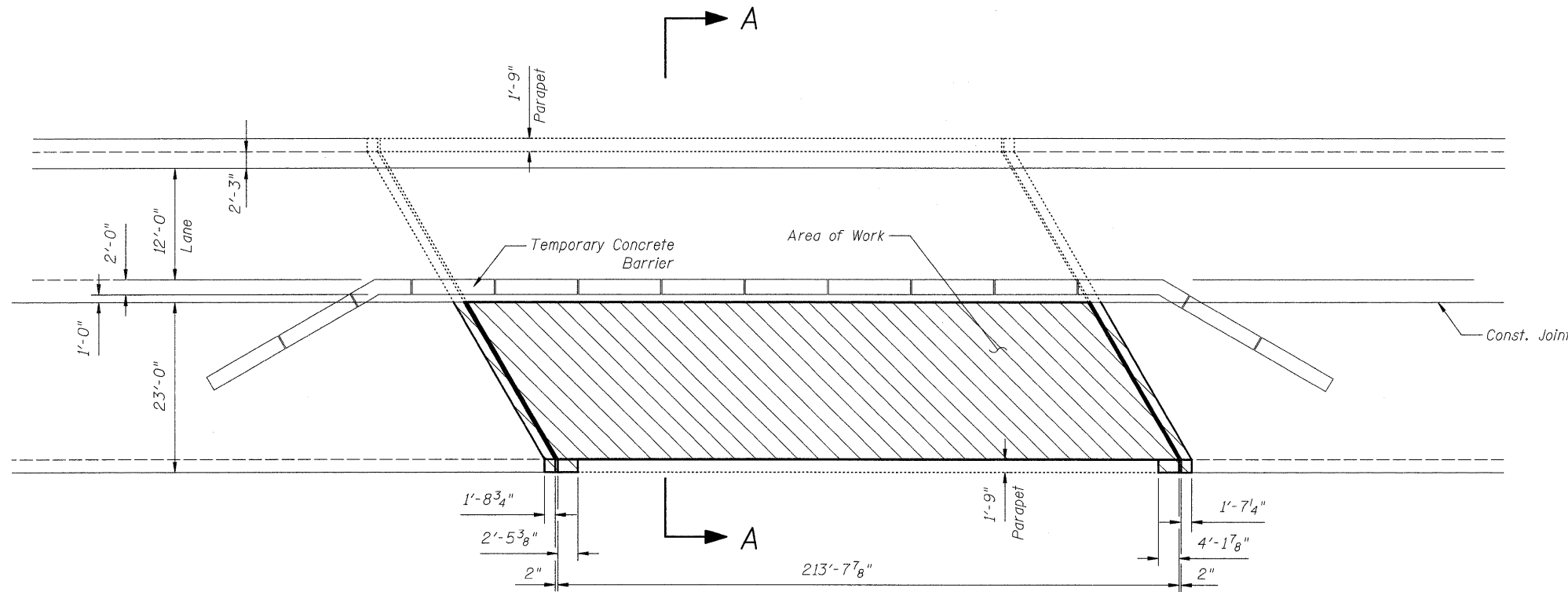

SECTION A-A

**STAGE I CONSTRUCTION**

- Install temporary concrete barrier as shown.\*
- Move traffic to Stage I traffic lanes.
- Sawcut concrete wearing surface and remove.
- Replace bridge joints and repair deck.
- Install new wearing surface & waterproofing membrane.
- \*For temporary concrete barrier details, see sheet 9 of 10.

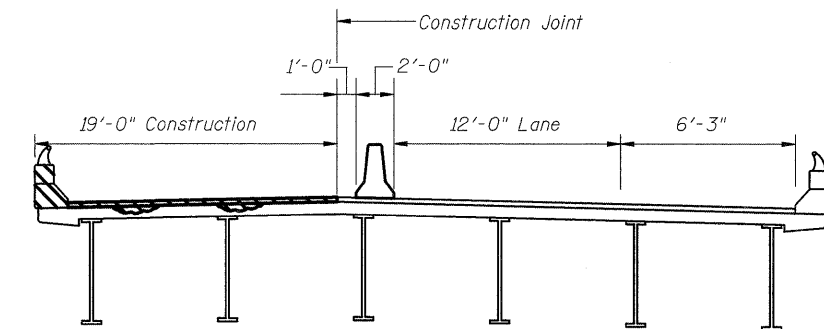
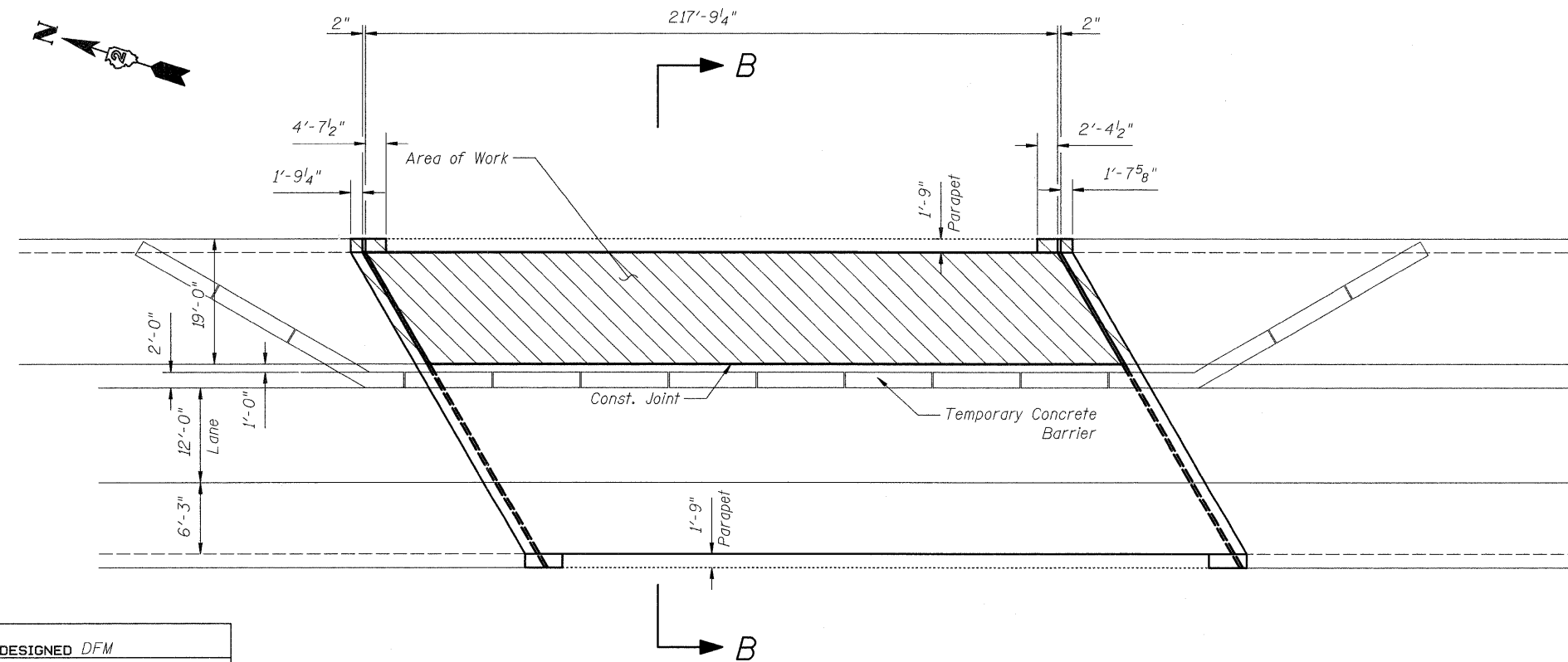

SECTION B-B

**STAGE II CONSTRUCTION**

- Relocate temporary concrete barrier as shown.\*
- Move traffic to Stage II traffic lanes.
- Remove concrete wearing surface.
- Replace bridge joints and repair deck.
- Install new wearing surface & waterproofing membrane.
- Remove temporary concrete barrier.

DESIGNED	DFM
CHECKED	DSG
DRAWN	EBS
CHECKED	DFM

**STAGING PLAN**  
**F.A.I. 74 (OVER 19TH ST.)**  
**ROCK ISLAND COUNTY**  
**STRUCTURE NO. 081-0104**

STATE OF ILLINOIS  
DEPARTMENT OF TRANSPORTATION

ROUTE NO.	SECTION	COUNTY	TOTAL SHEETS	SHEET NO.	SHEET NO.
FAI 74	*	ROCK ISLAND	246	180	10 SHEETS
FED. ROAD DIST. NO. 7	ILLINOIS	FED. AID PROJECT			

\* 81 (1-2, 1, 2-2) RS-1 & M

**BILL OF MATERIAL**

ITEM	UNIT	QUANTITY
Polymerized HMA Surface Course Mix "E", N90	TON	96
Protective Shield	SQ.YD.	232
Waterproofing Membrane System	SQ.YD.	924
Bridge Deck Scarification	SQ.YD.	917

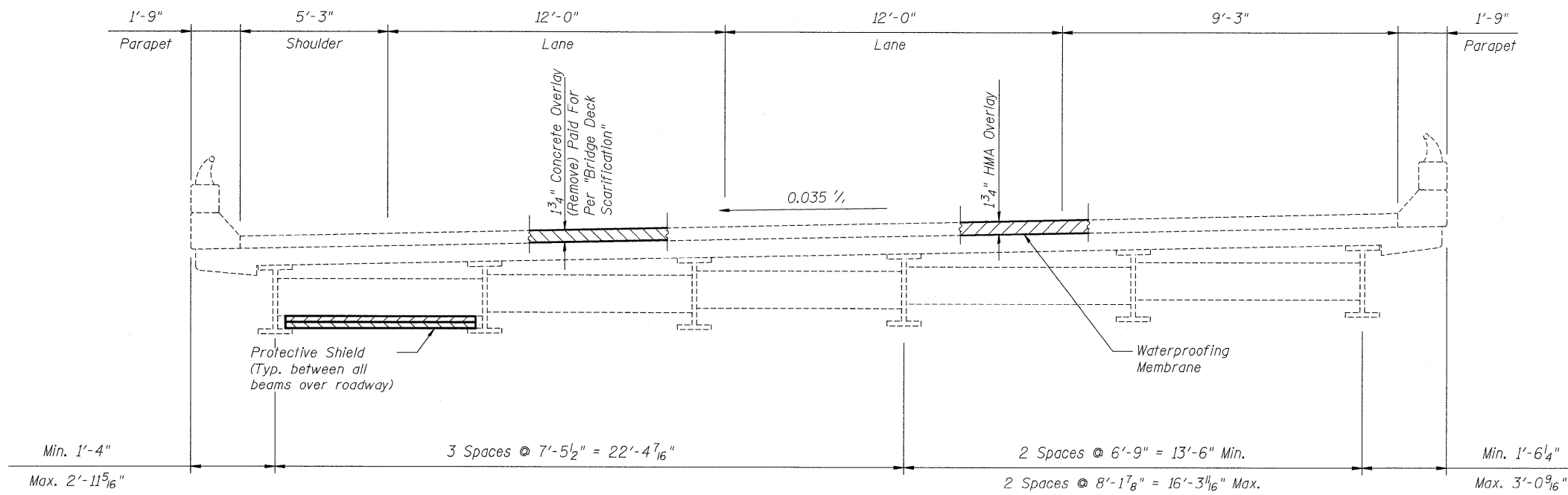

**CROSS SECTION**

(Looking South)

DESIGNED	DFM
CHECKED	DFM
DRAWN	EBS
CHECKED	DFM

**BRIDGE REPAIR DETAILS**  
**F.A.I. 74 (OVER 19TH ST.)**  
**ROCK ISLAND COUNTY**  
**STRUCTURE NO. 081-0104**



STATE OF ILLINOIS  
DEPARTMENT OF TRANSPORTATION

ROUTE NO.	SECTION	COUNTY	TOTAL SHEETS	SHEET NO.	SHEET NO. 4 10 SHEETS
FAI 74	*	ROCK ISLAND	246	181	
FED. ROAD DIST. NO. 7	ILLINOIS	FED. AID PROJECT-			

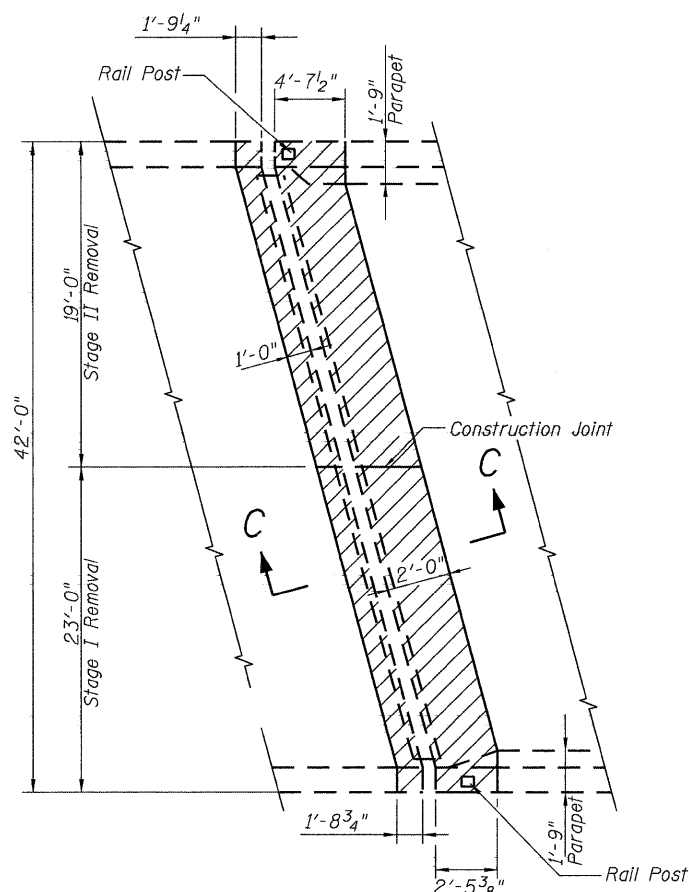

EXISTING PARTIAL PLAN - NORTH ABUTMENT

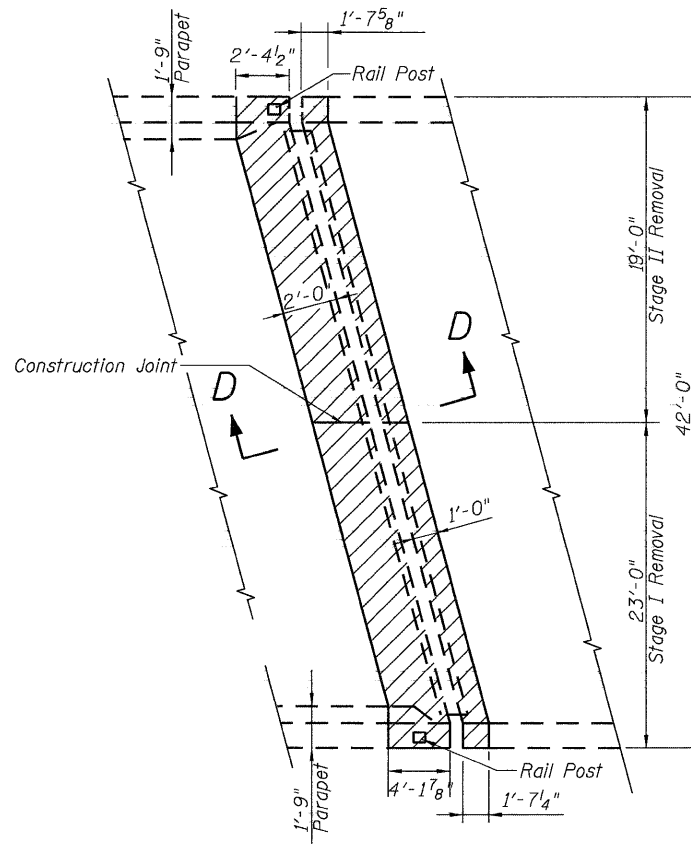

EXISTING PARTIAL PLAN - SOUTH ABUTMENT

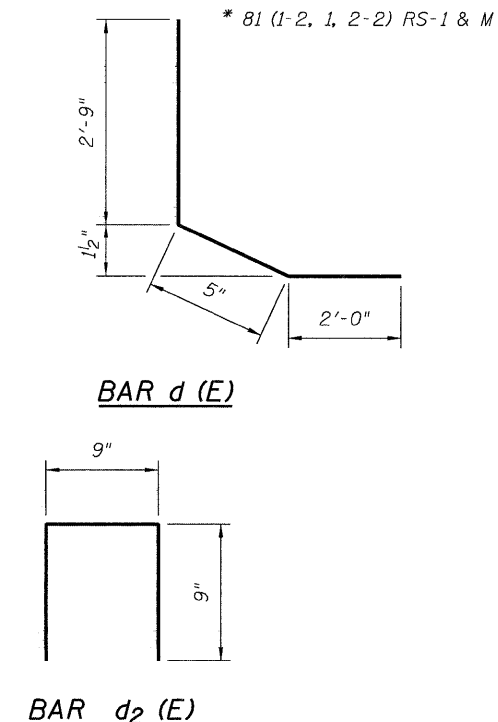
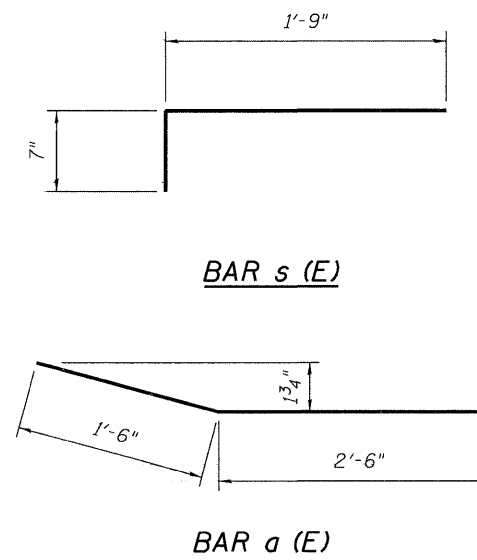

BILL OF MATERIAL

BAR	NO.	SIZE	LENGTH	SHAPE
a (E)	4	#6	4'-0"	
a <sub>1</sub> (E)	8	#5	31'-5"	
a <sub>2</sub> (E)	8	#5	37'-5"	
a <sub>3</sub> (E)	3	#6	31'-5"	
a <sub>4</sub> (E)	3	#6	37'-5"	
a <sub>5</sub> (E)	8	#5	29'-0"	
a <sub>6</sub> (E)	8	#5	34'-8"	
a <sub>7</sub> (E)	3	#6	29'-0"	
a <sub>8</sub> (E)	3	#6	34'-8"	
d (E)	16	#4	4'-0"	└┘
d <sub>1</sub> (E)	16	#5	2'-9"	└┘
d <sub>2</sub> (E)	8	#4	2'-3"	└┘
s (E)	80	#5	2'-4"	└┘
Reinforcement Bars Epoxy Coated			Pound	2100
Concrete Removal			Cu. Yd.	21.8
Concrete Superstructure			Cu. Yd.	21.8
Bar Splicer			Each	22

For bar splicer assembly details see sheet 8 of 10.  
For Rail Post Details see sheet 10 of 10.  
For sections C-C and D-D see sheet 5 of 10.

LEGEND

- Concrete Removal
- Concrete Superstructure

JOINT RECONSTRUCTION DETAILS  
F.A.I. 74 (OVER 19TH ST.)  
ROCK ISLAND COUNTY  
STRUCTURE NO. 081-0104

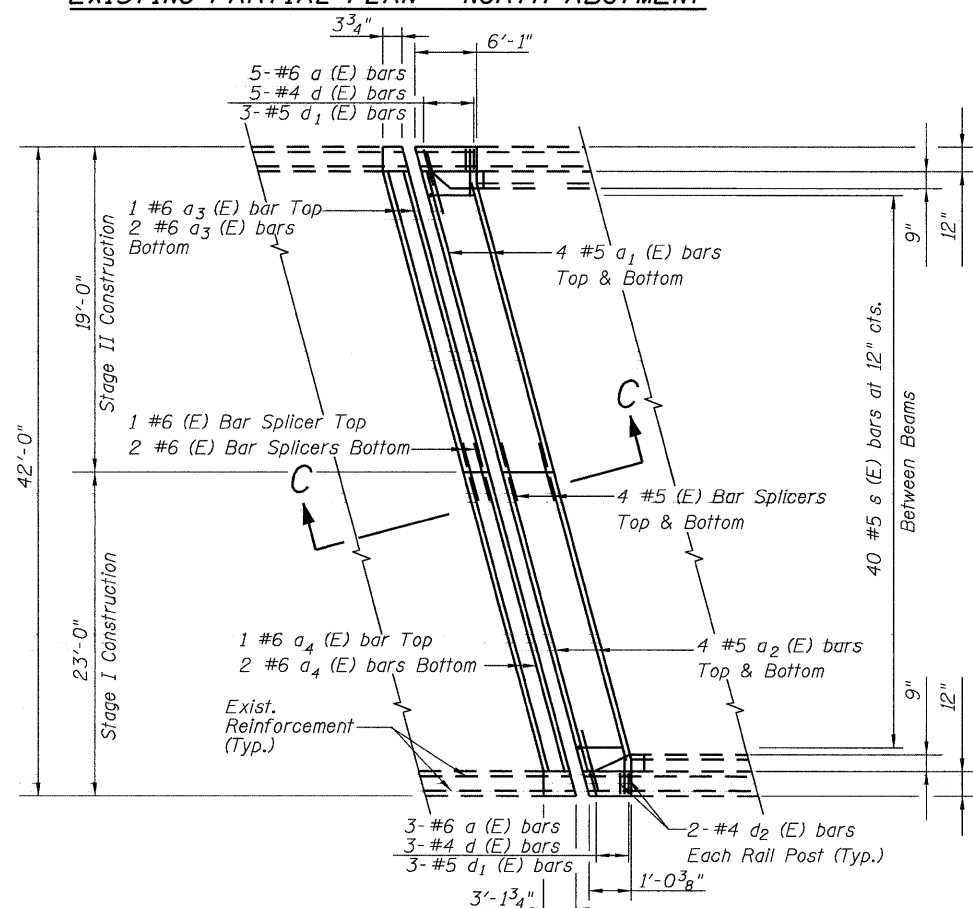

PROPOSED PARTIAL PLAN - NORTH ABUTMENT

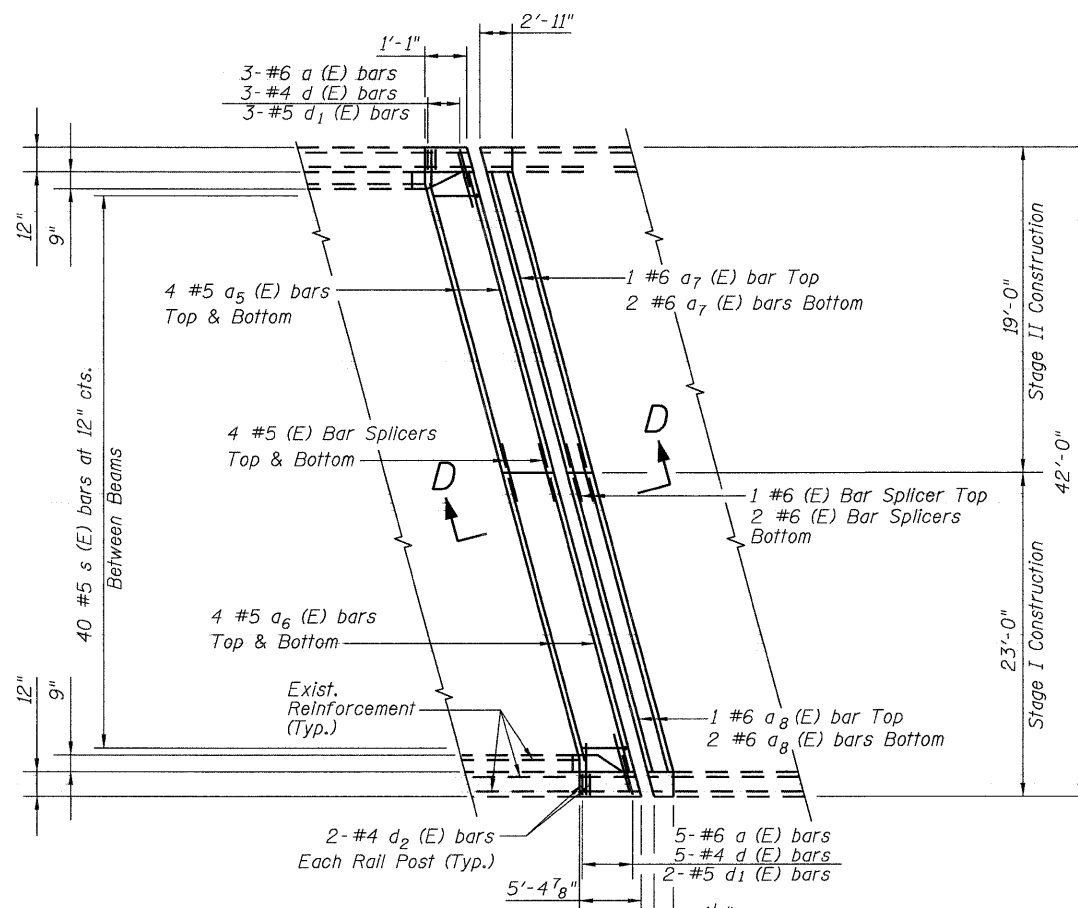

PROPOSED PARTIAL PLAN - SOUTH ABUTMENT

DESIGNED	DFM
CHECKED	DSG
DRAWN	EBS
CHECKED	DFM

STATE OF ILLINOIS  
DEPARTMENT OF TRANSPORTATION

ROUTE NO.	SECTION	COUNTY	TOTAL SHEETS	SHEET NO.	SHEET NO. 5
FAI 74	*	ROCK ISLAND	246	182	10 SHEETS
FED. ROAD DIST. NO. 7	ILLINOIS	FED. AID PROJECT-			

\* 81 (1-2, 1, 2-2) RS-1 & M

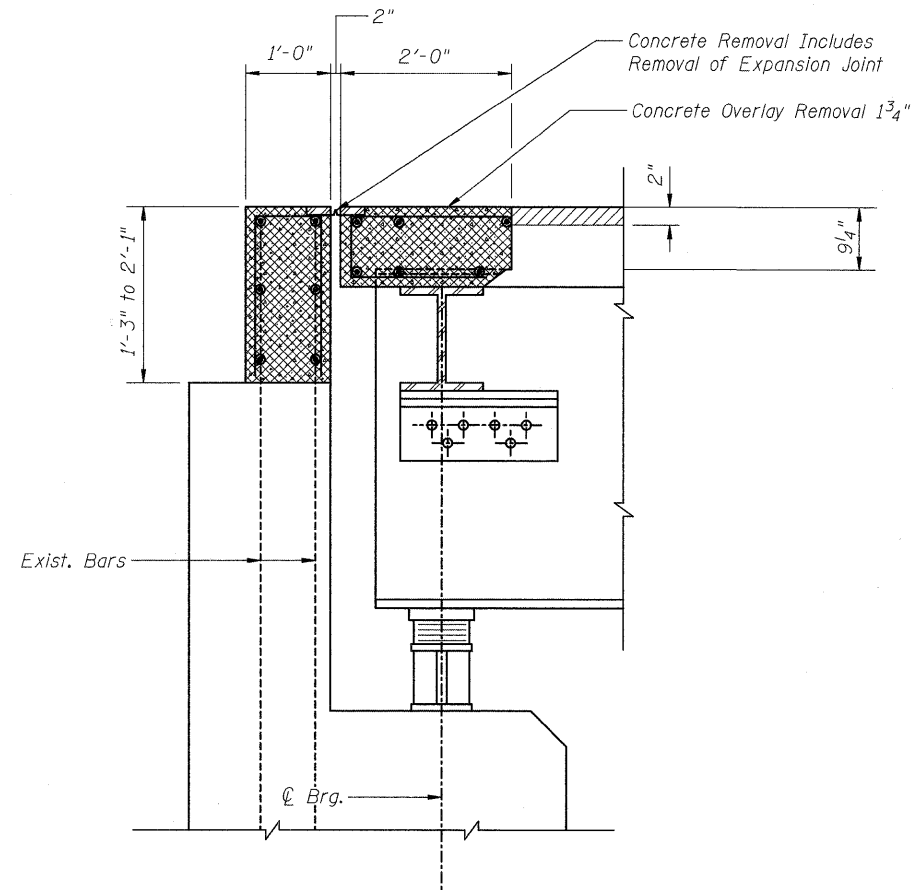

EXISTING SECTION C-C THRU NORTH ABUTMENT

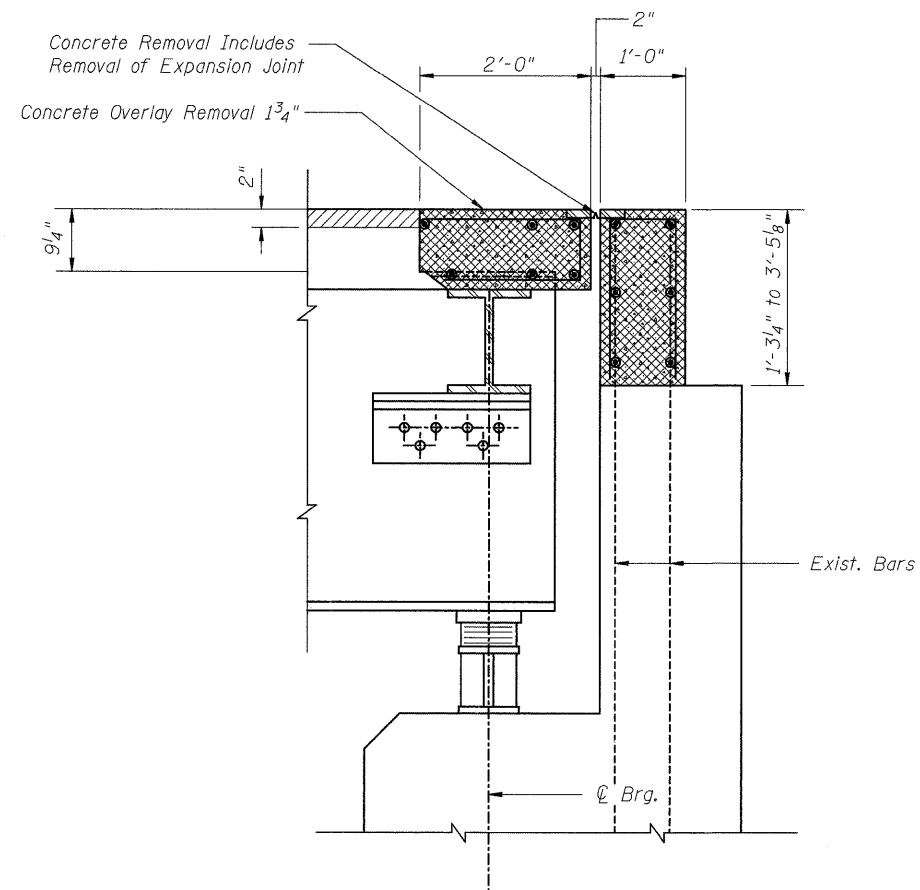

EXISTING SECTION D-D THRU SOUTH ABUTMENT

LEGEND

- Concrete Removal
- Bridge Deck Scarification

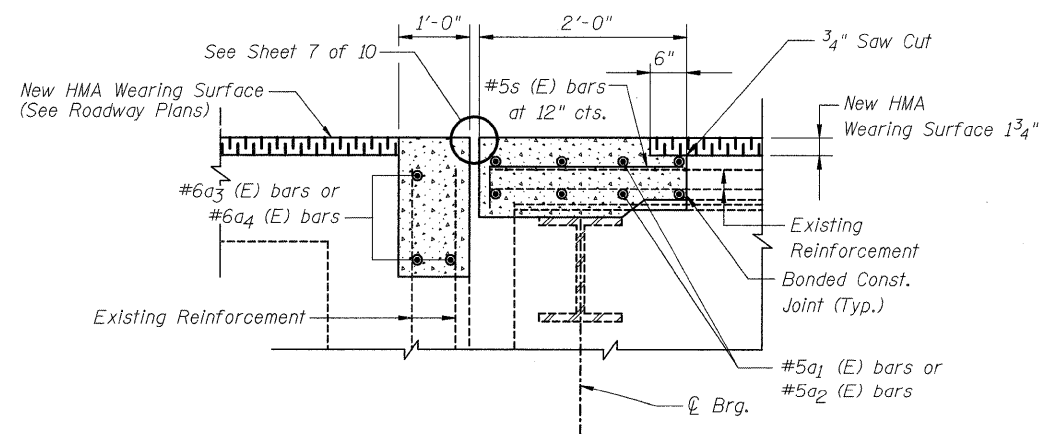

PROPOSED SECTION C-C THRU NORTH ABUTMENT

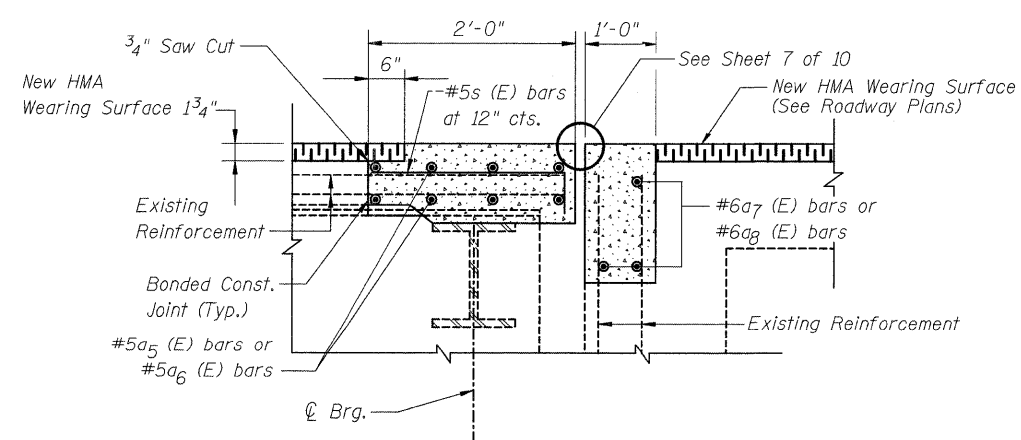

PROPOSED SECTION D-D THRU SOUTH ABUTMENT

DESIGNED	DFM
CHECKED	DFM
DRAWN	EBS
CHECKED	DFM

JOINT RECONSTRUCTION DETAILS  
F.A.I. 74 (OVER 19TH ST.)  
ROCK ISLAND COUNTY  
STRUCTURE NO. 081-0104

STATE OF ILLINOIS  
DEPARTMENT OF TRANSPORTATION

ROUTE NO.	SECTION	COUNTY	TOTAL SHEETS	SHEET NO.	SHEET NO.
FAI 74	*	ROCK ISLAND	246	183	10 SHEETS
FED. ROAD DIST. NO. 7	ILLINOIS	FED. AID PROJECT-			

\* 81 (1-2, 1, 2-2) RS-1 & M

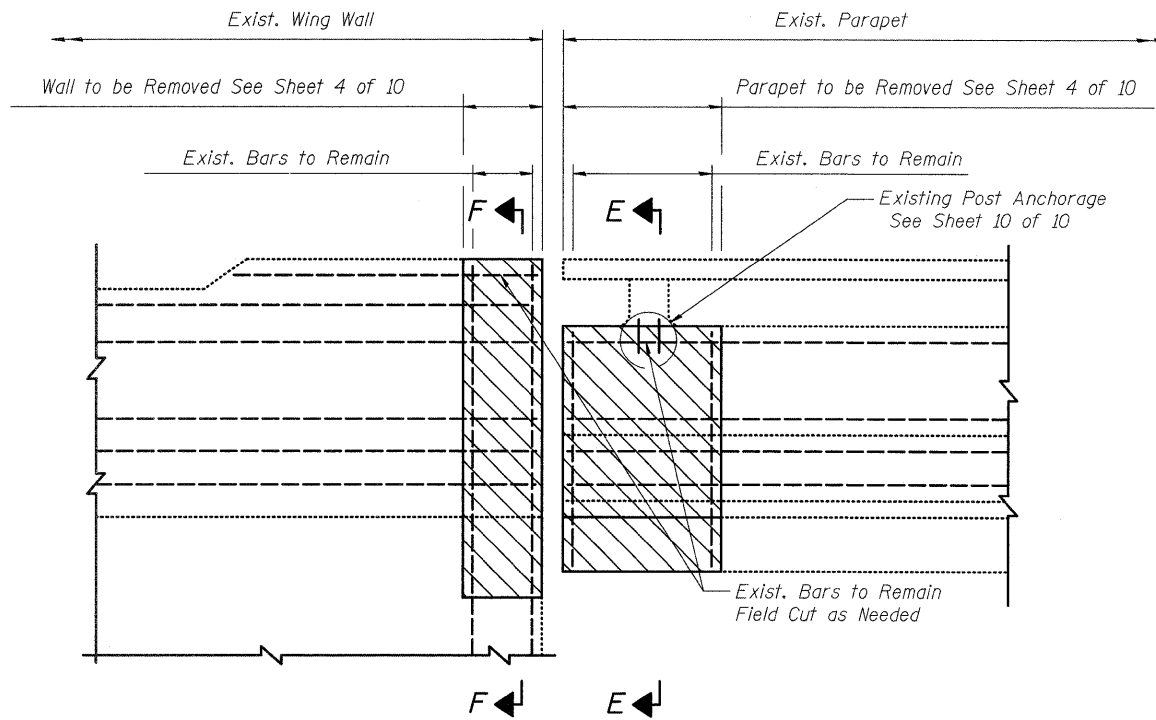

**ELEVATION OF CONCRETE REMOVAL THRU PARAPET AND WING WALL**

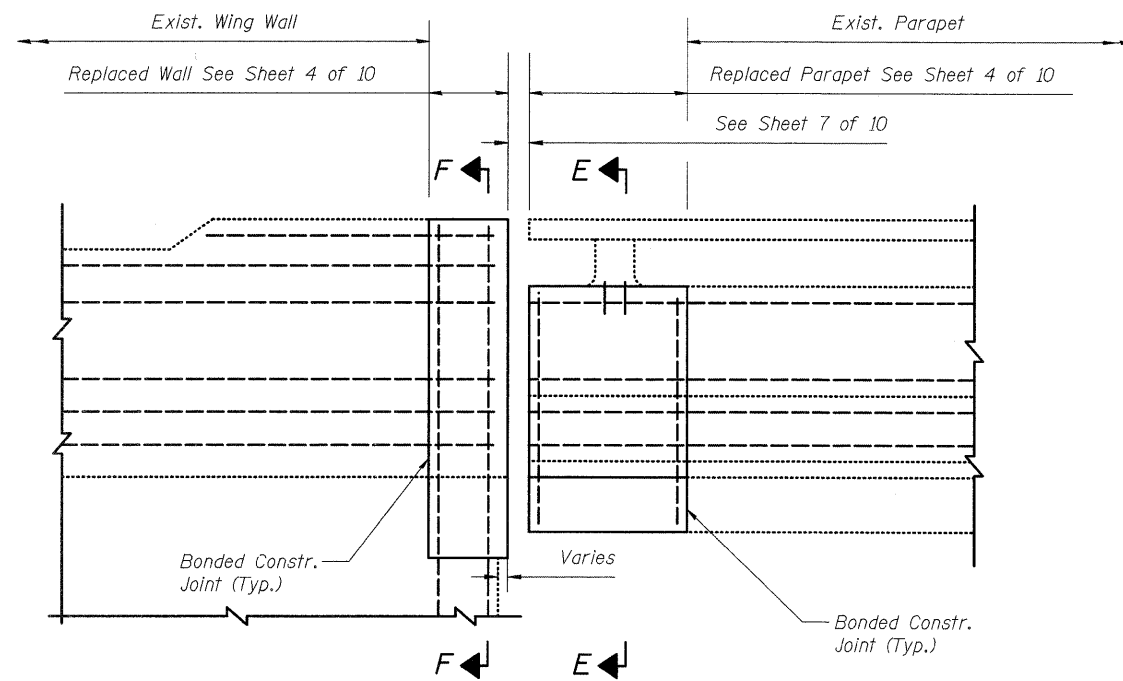

**ELEVATION OF CONCRETE REPLACEMENT THRU PARAPET AND WING WALL**

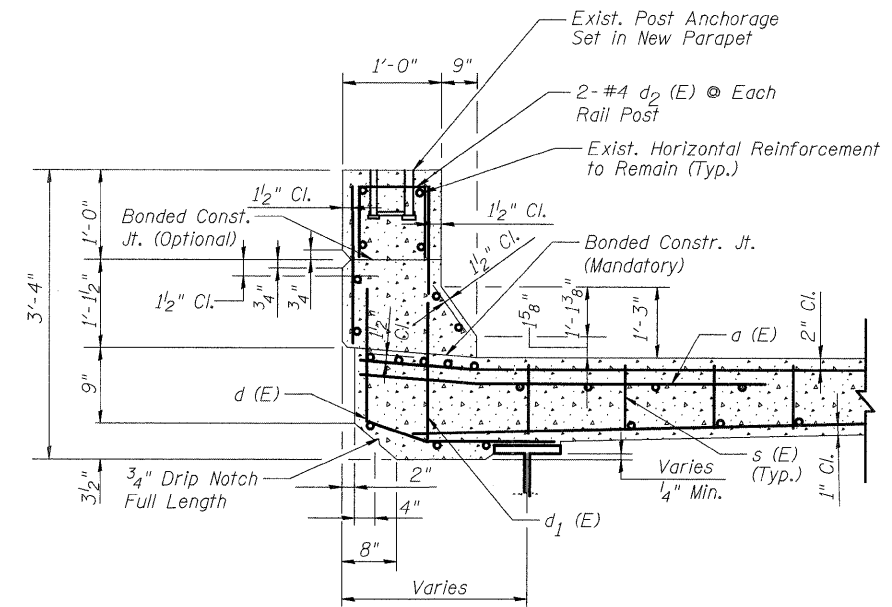

**SECTION E-E THRU BRIDGE DECK PARAPET**

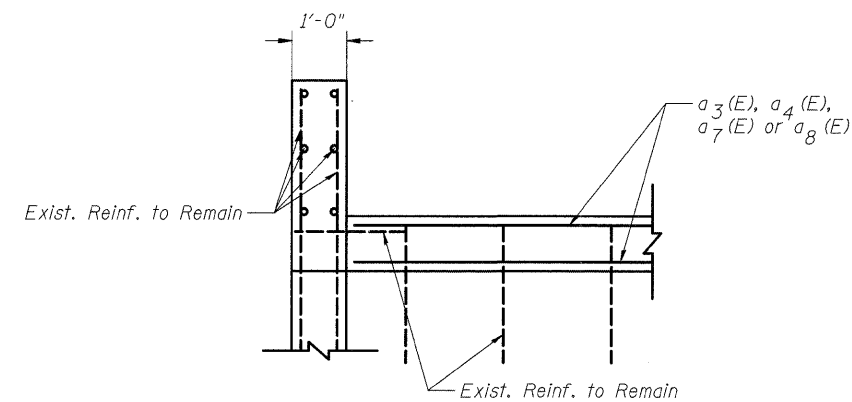

**SECTION F-F THRU ABUTMENT BACKWALL AND WING WALL**

DESIGNED	DFM
CHECKED	DSG
DRAWN	EBS
CHECKED	DFM

Note:

 Hatched areas indicate concrete sections to be removed and replaced. Perimeters of concrete removal areas shall be saw cut 3/4" prior to the removal of concrete.

**PARAPET AND RETAINING WALL DETAILS**  
**F.A.I. 74 (OVER 19TH ST.)**  
**ROCK ISLAND COUNTY**  
**STRUCTURE NO. 081-0104**

STATE OF ILLINOIS  
DEPARTMENT OF TRANSPORTATION

ROUTE NO.	SECTION	COUNTY	TOTAL SHEETS	SHEET NO.	SHEET NO. 7
FAI 74	*	ROCK ISLAND	246	184	10 SHEETS
FED. ROAD DIST. NO. 7	ILLINOIS	FED. AID PROJECT			

\*Granular or solid flux filled headed studs conforming to Article 1006.32 of the Std. Specs., automatically end welded.

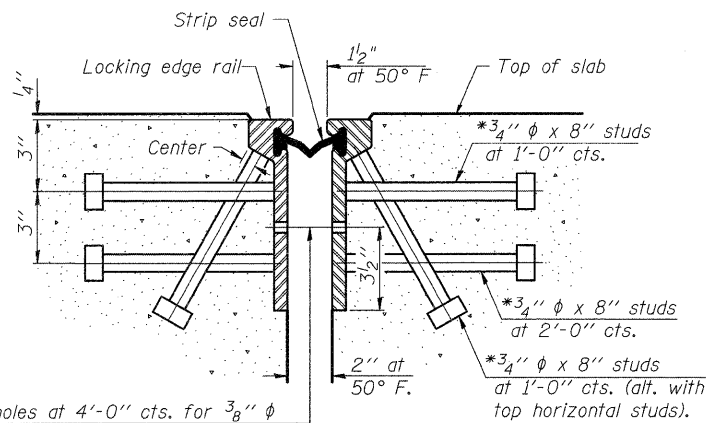

7/16"  $\phi$  holes at 4'-0" cts. for 3/8"  $\phi$  bolts. All bolts shall be burned, sawed, or chipped off flush with the plates after forms are removed, typ.

SECTION THRU ROLLED RAIL JOINT

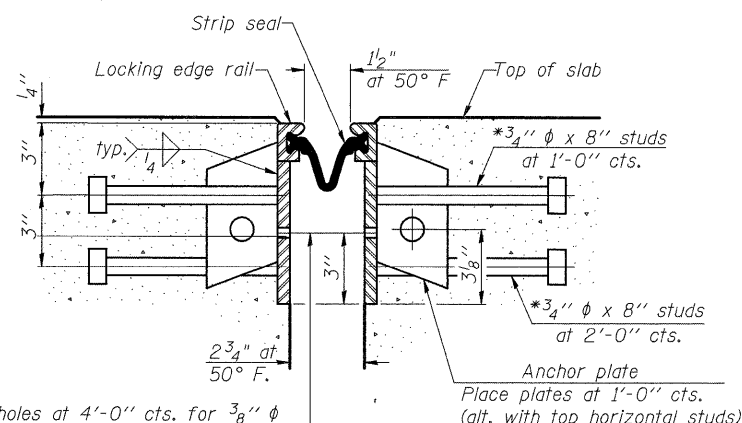

7/16"  $\phi$  holes at 4'-0" cts. for 3/8"  $\phi$  bolts. All bolts shall be burned, sawed, or chipped off flush with the plates after forms are removed, typ.

SECTION THRU WELDED RAIL JOINT

Notes:

\* 81 (1-2, 1, 2-2) RS-1 & M  
The strip seal shall be made continuous and shall have a minimum thickness of 1/4". The configuration of the strip seal shall match the configuration of the Locking Edge Rails. Open or "webbed" strip seal gland configurations are not permitted. The gland shall be sized for a maximum rated movement of 4 inches. The height and thickness of the Locking Edge Rails shown are minimum dimensions. The actual configuration of the Locking Edge Rails and matching strip seal may vary from manufacturer to manufacturer. Flanged edge rails will not be allowed. Locking Edge Rails may be spliced at slope discontinuities and stage construction joints. The manufacturer's recommended installation methods shall be followed. The joint opening and deck dimensions detailed on the superstructure are based on a rolled rail expansion joint. If the Contractor elects to use the welded rail expansion joint, the opening and deck dimensions shall be modified according to the dimensions detailed on this sheet. Required modifications shall be made at no additional cost to the State. All steel components shall be galvanized after fabrication according to Article 520.03 of the Standard Specifications.

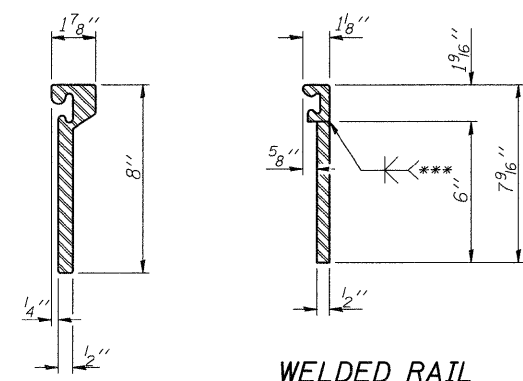

ROLLED EXTRUDED RAIL

WELDED RAIL

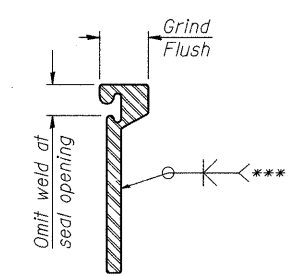

\*\*\*Back gouge not required if complete joint penetration is verified by mock-up.

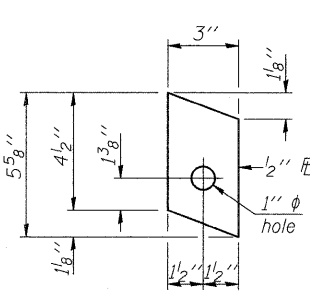

ANCHOR PLATE  
(for welded rail)

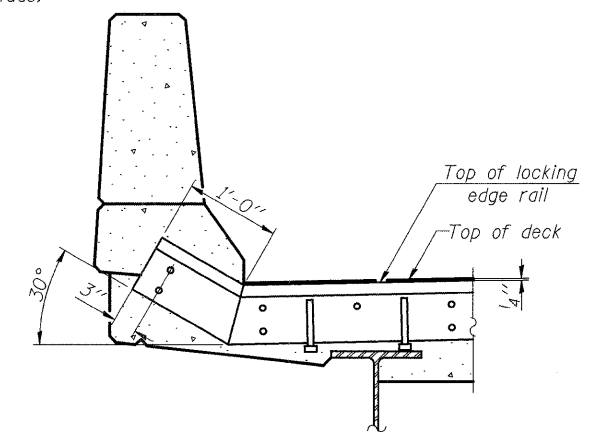

AT PARAPET

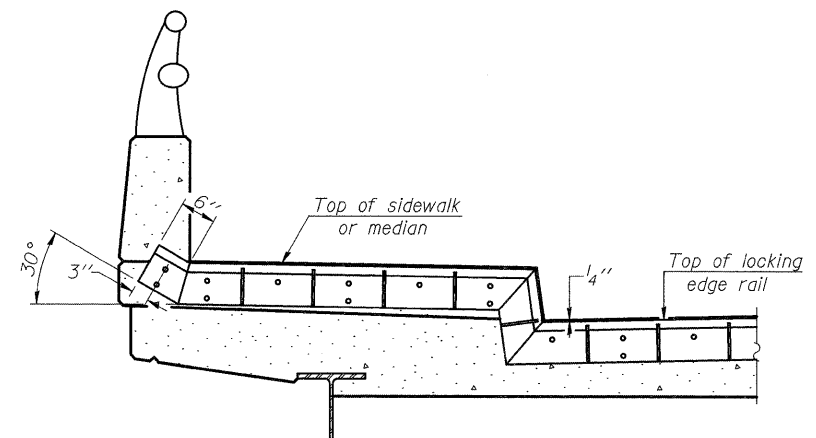

AT SIDEWALK OR MEDIAN

Shorter plates with a single row of studs at 12" cts. may be necessary on medians which are shallower than 9". See manufacturer's recommendation.

LOCKING EDGE RAIL SPLICE

The inside of the locking edge rail groove shall be free of weld residue.

LOCKING EDGE RAILS

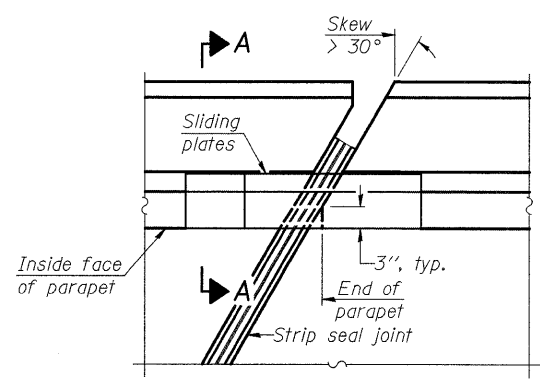

PLAN

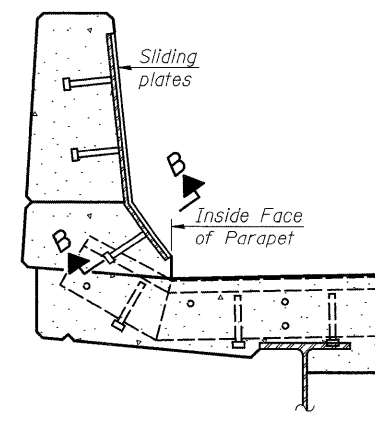

SECTION A-A

POINT BLOCK DETAILS  
(for skews > 30°)

TYPICAL END TREATMENTS

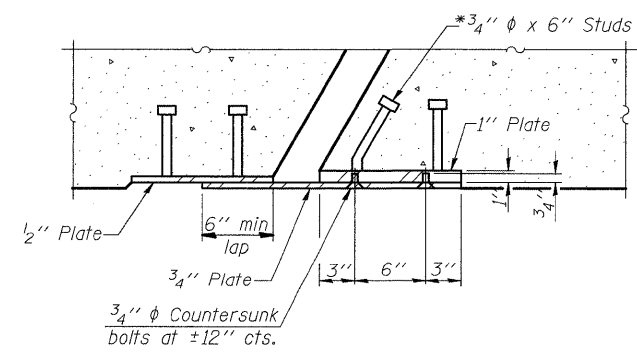

SECTION B-B

BILL OF MATERIAL

Item	Unit	Total
Preformed Joint Strip Seal	Foot	139

DESIGNED	DFM
CHECKED	DSG
DRAWN	EBS
CHECKED	DFM

EJ-SSJ 5-16-08

PREFORMED JOINT STRIP SEAL  
F.A.I. 74 (OVER 19TH ST.)  
ROCK ISLAND COUNTY  
STRUCTURE NO. 081-0104

STATE OF ILLINOIS  
DEPARTMENT OF TRANSPORTATION

ROUTE NO.	SECTION	COUNTY	TOTAL SHEETS	SHEET NO.	SHEET NO.
FAI 74	*	ROCK ISLAND	246	185	10 SHEETS
FED. ROAD DIST. NO. 7	ILLINOIS	FED. AID PROJECT-			

\* 81 (1-2, 1, 2-2) RS-1 & M

**NOTES**

Bar splicer assemblies shall be of an approved type and shall develop in tension at least 125 percent of the yield strength of the lapped reinforcement bars.  
Splicer rods shall be of minimum 60 ksi yield strength, threaded or coiled full length.  
All reinforcement bars shall be lapped and tied to the splicer rods or dowel bars.  
Bar splicer assemblies shall be epoxy coated according to the requirements for reinforcement bars.  
Other systems of similar design may be submitted to the Engineer for approval. Approval shall be based on certified test results from an approved testing laboratory that the proposed bar splicer assembly satisfies the following requirements:

- ① Minimum Capacity =  $1.25 \times f_y \times A_f$   
(Tension in kips)
  - ② Minimum \*Pull-out Strength =  $0.66 \times f_y \times A_f$   
(Tension in kips)
- Where  $f_y$  = Yield strength of lapped reinforcement bars in ksi.  
 $A_f$  = Tensile stress area of lapped reinforcement bars.  
\* = 28 day concrete

**BAR SPLICER ASSEMBLIES**

Bar Size to be Spliced	Splicer Rod or Dowel Bar Length	Strength Requirements	
		Min. Capacity kips - tension	Min. Pull-Out Strength kips - tension
#4	1'-8"	14.7	7.9
#5	2'-0"	23.0	12.3
#6	2'-7"	33.1	17.4
#7	3'-5"	45.1	23.8
#8	4'-6"	58.9	31.3
#9	5'-9"	75.0	39.6
#10	7'-3"	95.0	50.3
#11	9'-0"	117.4	61.8

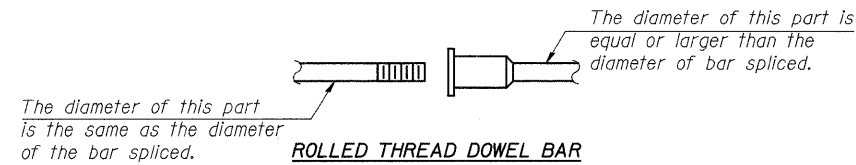

Wire Connector

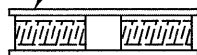

**BAR SPLICER ASSEMBLY ALTERNATIVES**

\*\*Heavy Hex Nuts conforming to ASTM A 563, Grade C, D or DH may be used.

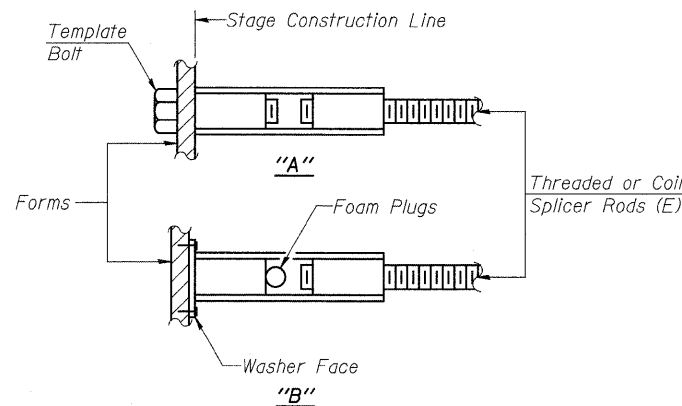

**INSTALLATION AND SETTING METHODS**

"A" :Set bar splicer assembly by means of a template bolt.  
"B" :Set bar splicer assembly by nailing to wood forms or cementing to steel forms.  
(E) : Indicates epoxy coating.

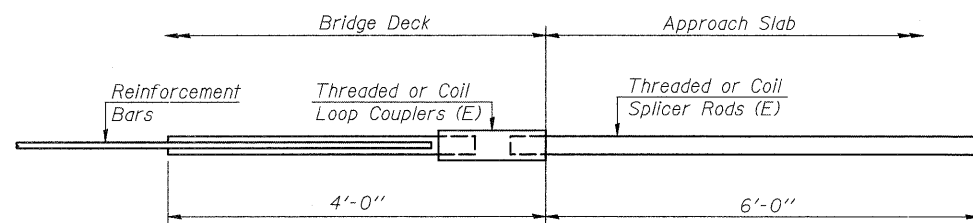

**FOR INTEGRAL OR SEMI-INTEGRAL ABUTMENTS**

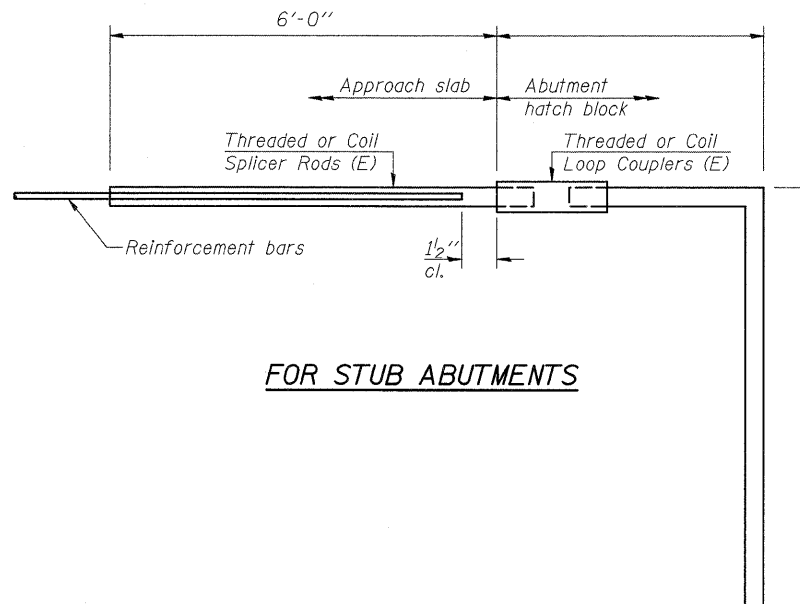

**FOR STUB ABUTMENTS**

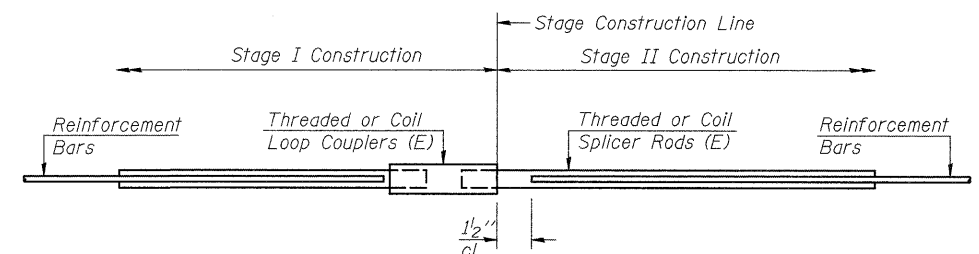

**STANDARD**

Bar Splicer for #5 bar
Min. Capacity = 23.0 kips - tension
Min. Pull-out Strength = 12.3 kips - tension
No. Required =

Bar Splicer for #5 bar
Min. Capacity = 23.0 kips - tension
Min. Pull-out Strength = 12.3 kips - tension
No. Required =

Bar Size	No. Assemblies Required	Location
#5	8	Bridge Deck at South Abutment
#5	8	Bridge Deck at North Abutment
#6	3	South Abutment Backwall
#6	3	North Abutment Backwall

DESIGNED DFM
CHECKED DSG
DRAWN EBS
CHECKED DFM

BSD-1

5-16-08

**BAR SPLICER ASSEMBLY DETAILS**  
**F.A.I. 74 (OVER 19TH ST.)**  
**ROCK ISLAND COUNTY**  
**STRUCTURE NO. 081-0104**

STATE OF ILLINOIS  
DEPARTMENT OF TRANSPORTATION

ROUTE NO.	SECTION	COUNTY	TOTAL SHEETS	SHEET NO.	SHEET NO. 9
FAI 74	*	ROCK ISLAND	246	186	10 SHEETS
FED. ROAD DIST. NO. 7	ILLINOIS	FED. AID PROJECT-			

\* 81 (1-2, 1, 2-2) RS-1 & M

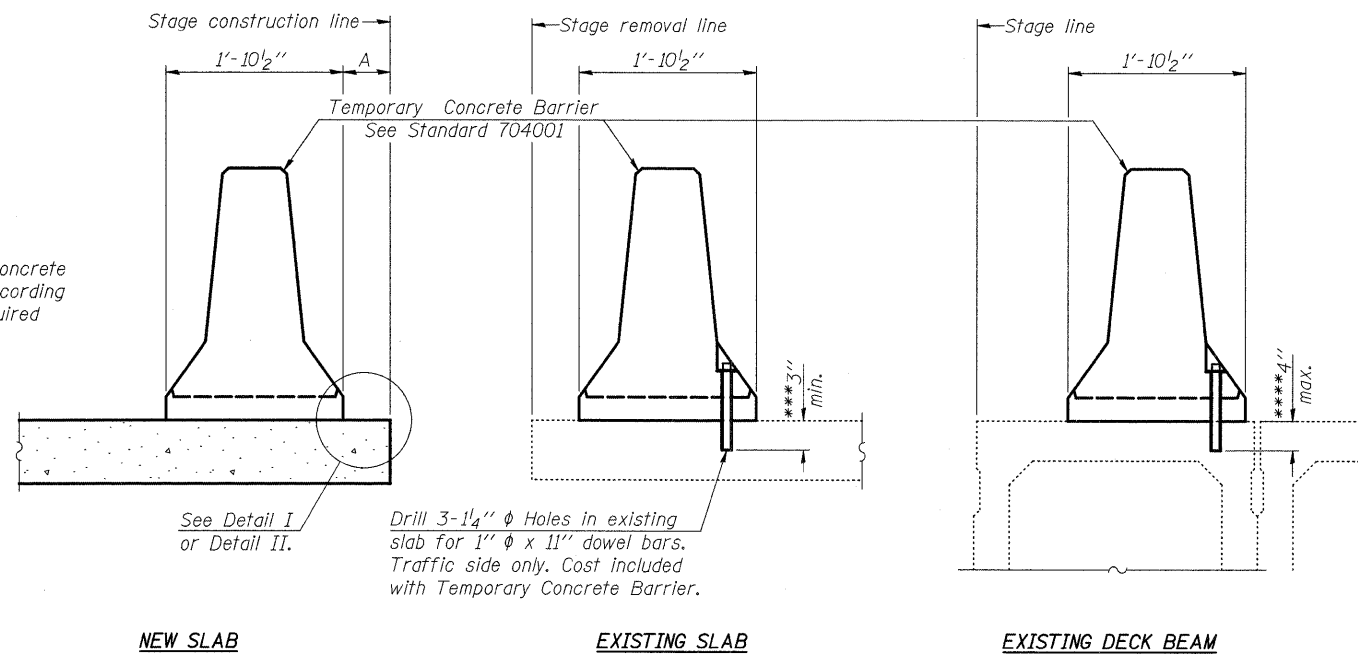

When "A" is 3'-6" or less, the temporary concrete barrier shall be anchored to the new slab according to Detail I or Detail II. No anchorage is required when "A" is greater than 3'-6".

NEW SLAB

EXISTING SLAB

EXISTING DECK BEAM

See Detail I or Detail II.

Drill 3-1/4"  $\phi$  Holes in existing slab for 1"  $\phi$  x 11" dowel bars. Traffic side only. Cost included with Temporary Concrete Barrier.

NOTES

Detail I - With Bar Splicer or Couplers:  
Connect one (1) 1"x7"x10" steel PL to the top layer of couplers with 2-5/8"  $\phi$  bolts screwed to coupler at approximate  $\phi$  of each barrier panel.

Detail II - With Extended Reinforcement Bars:  
Connect one (1) 1"x7"x10" steel PL to the concrete slab or concrete wearing surface with 2-5/8"  $\phi$  Expansion Anchors or cast in place inserts spaced between the top layer of reinforcement at approximate  $\phi$  of each barrier panel.

Cost of anchorage is included with Temporary Concrete Barrier. The 1" x 7" x 10" plate shall not be removed until stage II construction forms and all reinforcement bars are in place and the concrete is ready to be placed.

SECTIONS THRU SLAB OR DECK BEAM

\*\*\*Dimension shown is minimum required embedment into concrete. If hot-mix asphalt wearing surface is present, minimum embedment shall be in addition to wearing surface depth.  
\*\*\*\*If existing deck beam is to remain in place after stage construction, embedment shall only be into wearing surface and not into existing deck beam concrete.

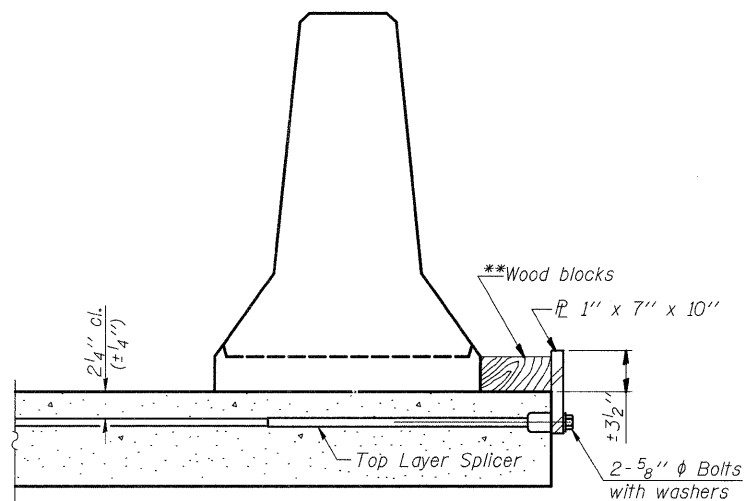

DETAIL I

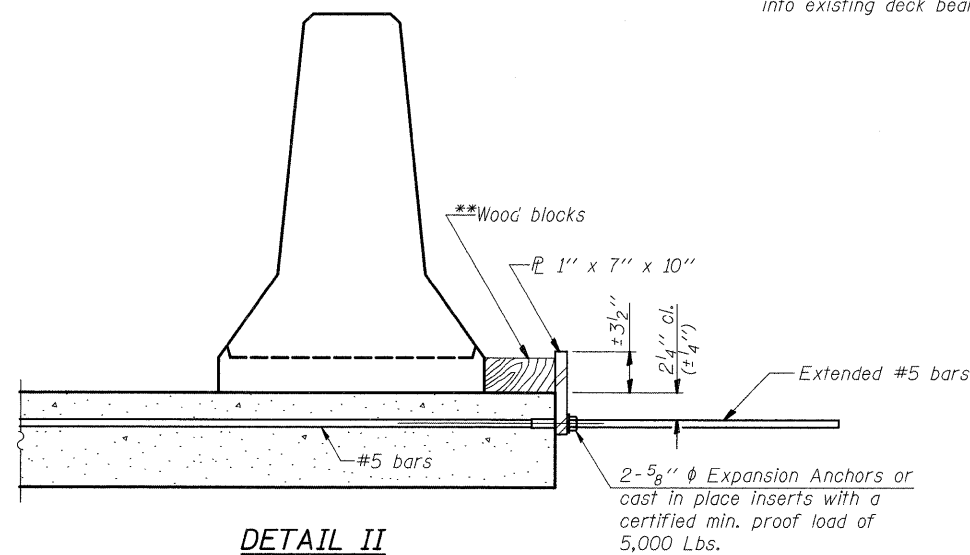

DETAIL II

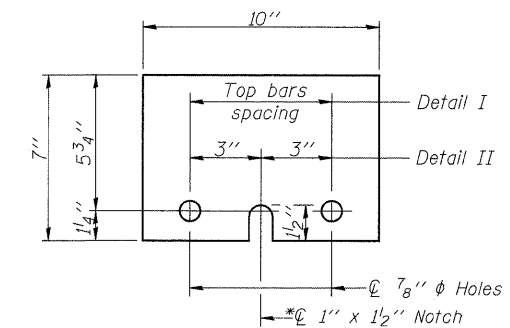

STEEL RETAINER PL 1" x 7" x 10"

\*Required only with Detail II

\*\*Wood blocks may be omitted when required to provide minimum stage traffic lane width. When the wood blocks are omitted, the concrete barrier shall be in direct contact with the steel retainer plate.

DESIGNED	DFM
CHECKED	DSG
DRAWN	EBS
CHECKED	DFM

TEMPORARY CONCRETE BARRIER  
FOR STAGE CONSTRUCTION  
F.A.I. 74 (OVER 19TH ST.)  
ROCK ISLAND COUNTY  
STRUCTURE NO. 081-0104

STATE OF ILLINOIS  
DEPARTMENT OF TRANSPORTATION

ROUTE NO.	SECTION	COUNTY	TOTAL SHEETS	SHEET NO.	SHEET NO. 10
FAI 74	*	ROCK ISLAND	246	107	10 SHEETS
FED. ROAD DIST. NO. 7	ILLINOIS	FED. AID PROJECT-			

\* 81 (1-2, 1, 2-2) RS-1 & M

**NOTE:**  
Seal perimeter of post to parapet with two component non-staining gray sealing compound with polysulfide liquid polymers-gun grade with primer.

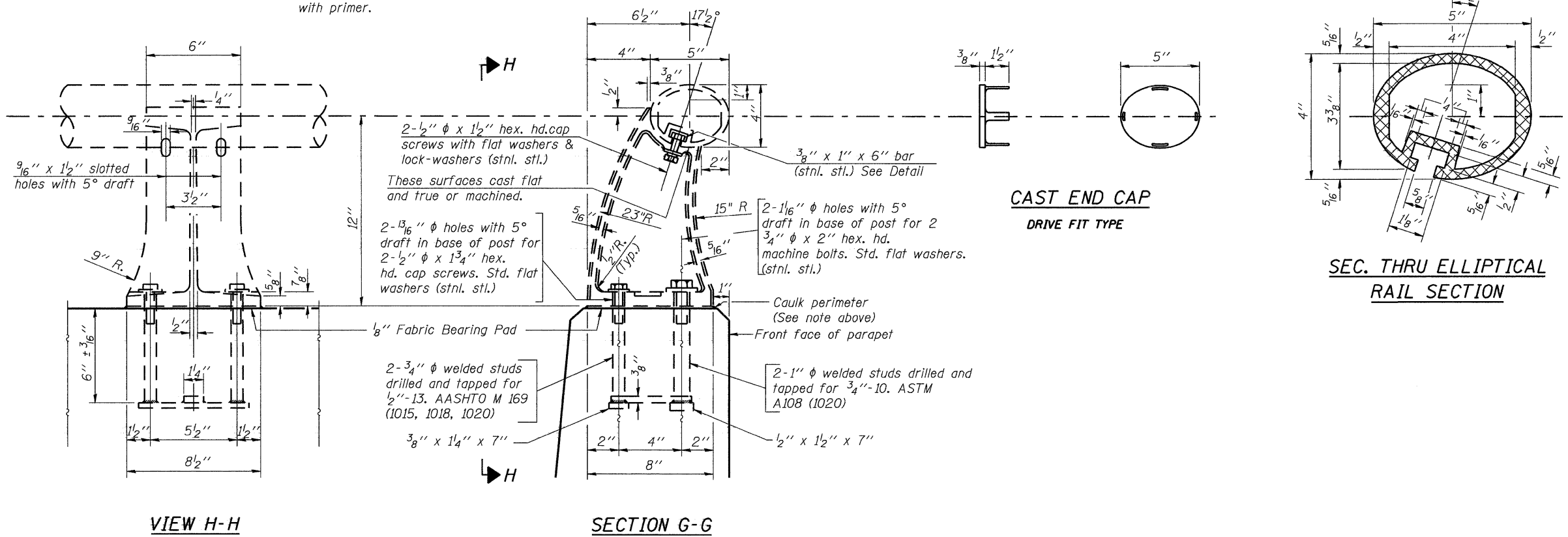

**RAIL POST DETAILS**

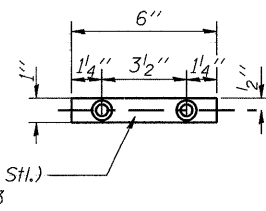

**CLAMP BAR**

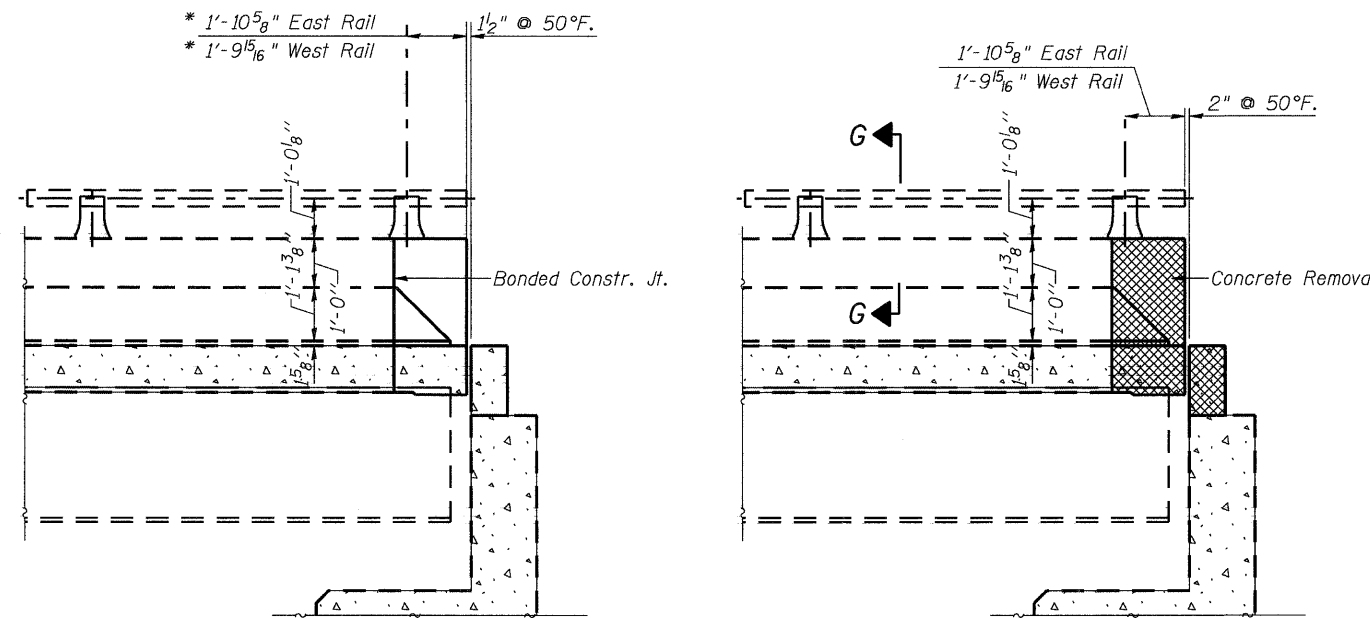

**INSIDE VIEW AT PROPOSED ABUTMENT**

**INSIDE VIEW AT EXISTING ABUTMENT**

Notes:

For concrete removal limits See Sheet 4 of 10.

Remove and reuse railing, including posts and anchors, where concrete removal affects existing rail posts. Cost included with Concrete Superstructure. If anchors are damaged during construction, they shall be replaced and are included with Concrete Removal.

\* Actual distance varies. New Joints are skewed through Parapet. Length of rail shall be adjusted as necessary with a flush cut and the cast end cap shall be reused.

DESIGNED	DFM
CHECKED	DSG
DRAWN	EBS
CHECKED	DFM

**RAILING DETAILS**  
F.A.I. 74 (OVER 19TH ST.)  
ROCK ISLAND COUNTY  
STRUCTURE NO. 081-0104

STATE OF ILLINOIS  
DEPARTMENT OF TRANSPORTATION

ROUTE NO.	SECTION	COUNTY	DATE	SHEET	SHEET NO.
FAI 74	*	ROCK ISLAND	246	188	11 SHEETS
FED. ROAD DIST. NO. 7	ILLINOIS	FED. AID PROJECT			

\* 81 (1-2, 1, 2-2) RS-1 & M

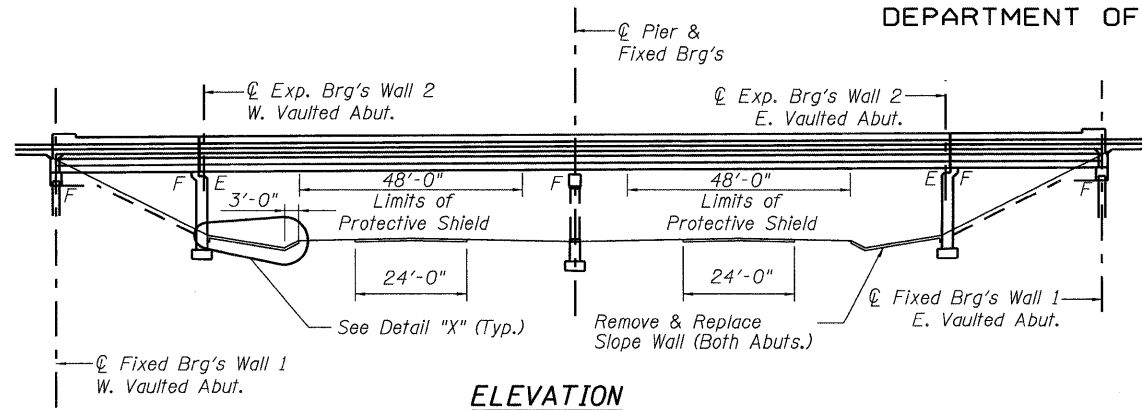

ELEVATION

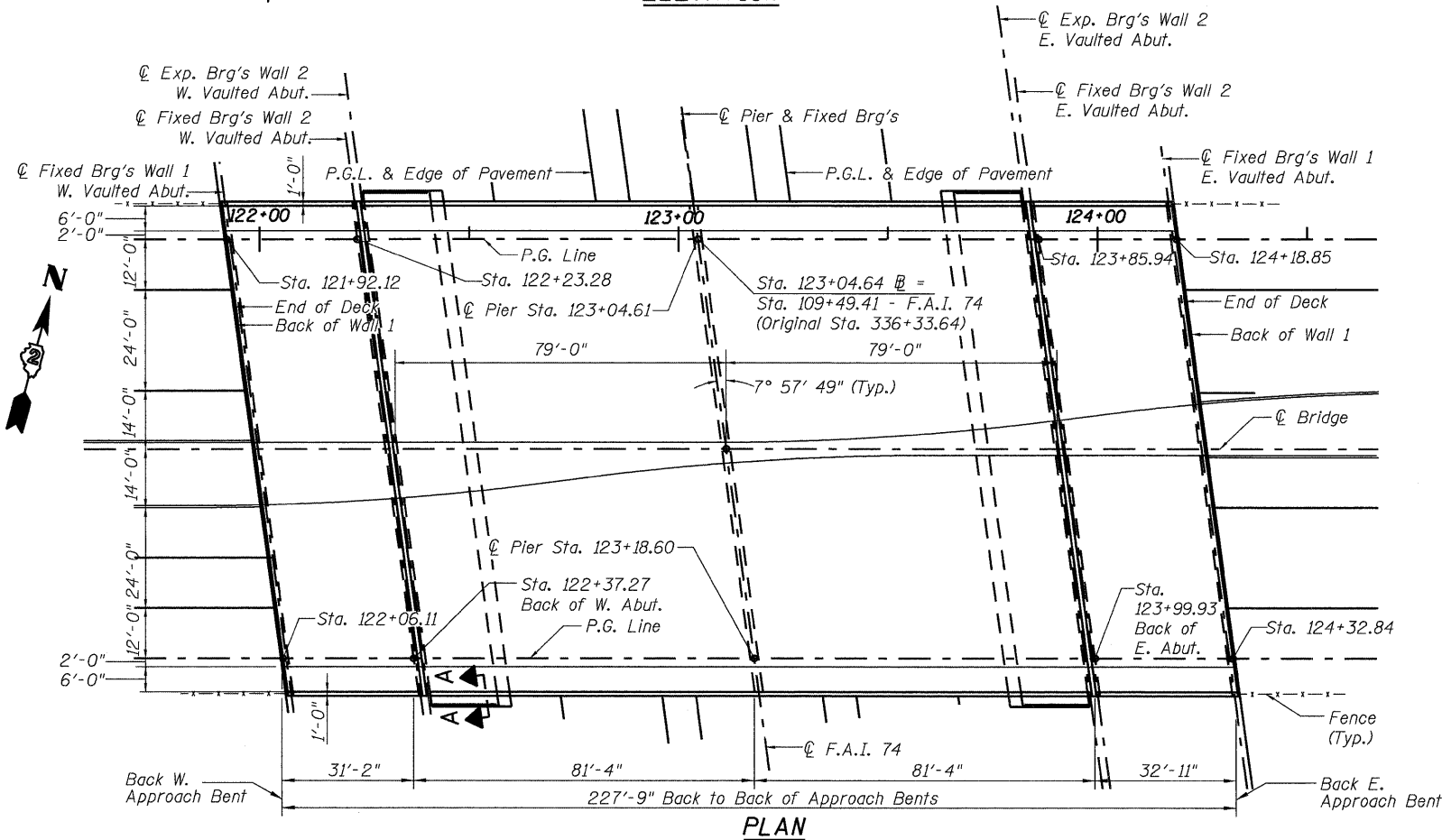

PLAN

TOTAL BILL OF MATERIAL

ITEM	UNIT	QUANTITY
Polymerized HMA Surface Course Mix "E", N 90	TON	348
Concrete Removal	CU.YD.	27.3
Slope Wall Removal	SQ.YD.	554
Protective Shield	SQ.YD.	1179
Concrete Superstructure	CU.YD.	27.3
Reinforcement Bars, Epoxy Coated	POUND	3770
Bar Splicers	EACH	44
Slope Wall (4 inch)	SQ.YD.	554
Waterproofing Membrane System	SQ.YD.	2340
Silicone Joint Sealer	FOOT	234
Preformed Joint Strip Seal	FOOT	240
Structural Repair of Concrete (Depth >5")	SQ.FT.	162
Bridge Deck Scarification	SQ.YD.	2330
Deck Slab Repair (Full Depth Type II)	SQ.YD.	3
Deck Slab Repair (Partial Depth)	SQ.YD.	27
Diamond Grinding (Bridge Section)	SQ.YD.	2340

GENERAL NOTES

No field welding is permitted except as specified in the contract documents.

Reinforcement bars shall conform to the requirements of ASTM A706 Grade 60. See Special Provisions.

Reinforcement bars designated (E) shall be epoxy coated.

Plan dimensions and details relative to existing plans are subject to nominal construction variations. The Contractor shall field verify existing dimensions and details affecting new construction and make necessary approved adjustments prior to construction or ordering of materials. Such variations shall not be cause for additional compensation for a change in scope of work, however, the Contractor will be paid for the quantity actually furnished at the unit price bid for the work.

Prior to pouring the new concrete deck, all heavy or loose rust, loose mill scale, and all other loose, potentially detrimental foreign material shall be removed from the surfaces in contact with concrete. Tightly adhered paint may remain unless otherwise noted. Removal shall be accomplished by methods that will not damage the steel and the cost will be included in the pay item covering removal of the existing concrete.

Quantities of Deck Slab Repair (Full Depth, Type II), and Deck Slab Repair (Partial Depth) are approximated and are intended for sidewalk only. Locations along the sidewalk will be determined by the resident Engineer. Actual repair locations shall be shown on the as-built plans.

The existing structural steel coating contains lead. The contractor shall take appropriate precautions to deal with the presence of lead on this project.

Joint openings shall be adjusted according to article 520.04 of the standard specifications when the deck is poured at an ambient temperature other than 50° F.

Existing reinforcement bars extending into the removal areas shall be cleaned, straightened and incorporated into the new construction. Any reinforcement bars that are damaged during concrete removal shall be replaced with approved bar splicer or anchorage system. Cost included with concrete removal.

Note:

For Section A-A, Detail "X" & Bridge Sidewalk Repair see Sheet 3 of 11.

DESIGNED	DFM
CHECKED	DSG
DRAWN	EBS
CHECKED	DFM

STATE OF ILLINOIS  
DAVID  
F. MAXWELL  
081-005455  
ST. LOUIS, MO.  
LICENSED STRUCTURAL ENGINEER

David F. Maxwell, S.E.      Reg. No. 081-005455  
Date: 11/21/08  
My registration expires November 30, 2010.

PLAN AND ELEVATION  
23RD AVE. OVER F.A.I. 74  
ROCK ISLAND COUNTY  
STRUCTURE NO. 081-0105



STATE OF ILLINOIS  
DEPARTMENT OF TRANSPORTATION

ROUTE NO.	SECTION	COUNTY	TOTAL SHEETS	SHEET NO.	SHEET NO. 2
FAI 74	*	ROCK ISLAND	246	189	11 SHEETS
FED. ROAD DIST. NO. 7	ILLINOIS	FED. AID PROJECT-			

\* 81 (1-2, 1, 2-2) RS-1 & M

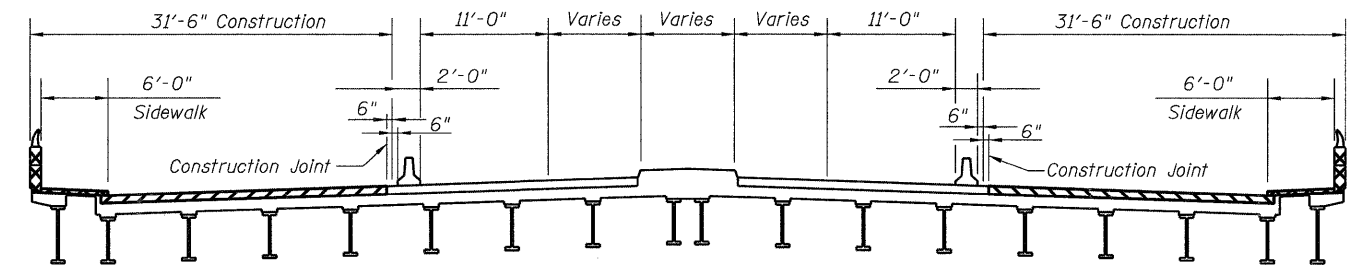
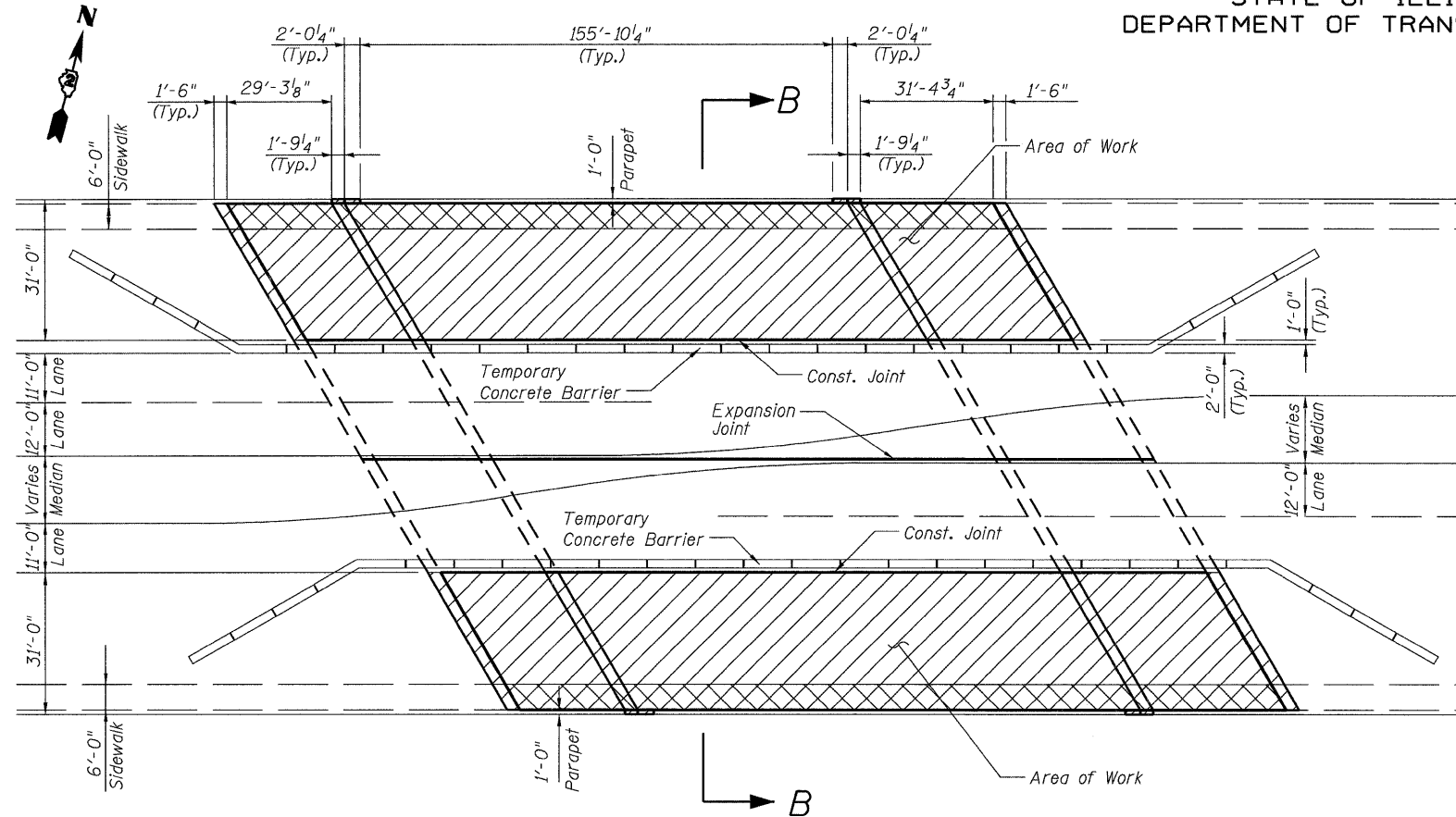

SECTION B-B

**STAGE I CONSTRUCTION**

Install temporary concrete barrier as shown. \*



Move traffic to Stage I traffic lanes.

Sawcut concrete wearing surface and remove.

Replace bridge joints and repair sidewalks.

Install new wearing surface & waterproofing membrane.

Note: North and South Sidewalks shall not be closed at the same time during construction. One sidewalk to remain open at all times.

-  Deck overlay Replacement
-  Sidewalk Repair (paid for as Deck Slab Repair)

\* For temporary concrete barrier details, see sheet 10 of 11.

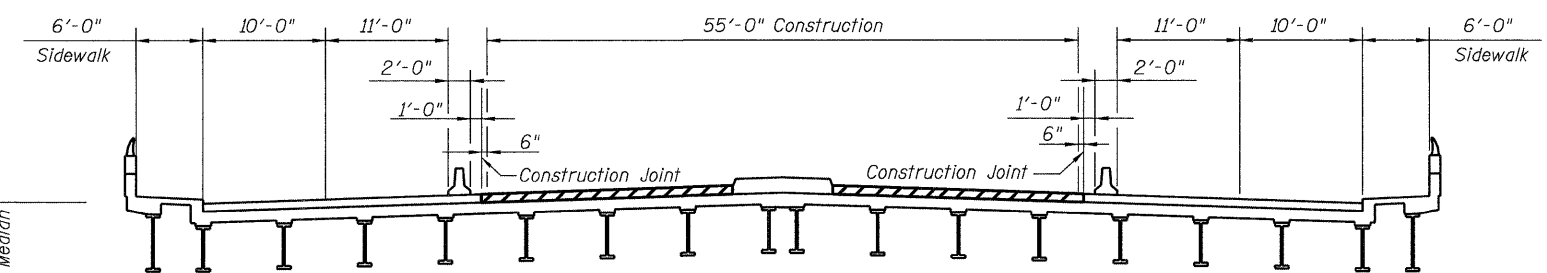
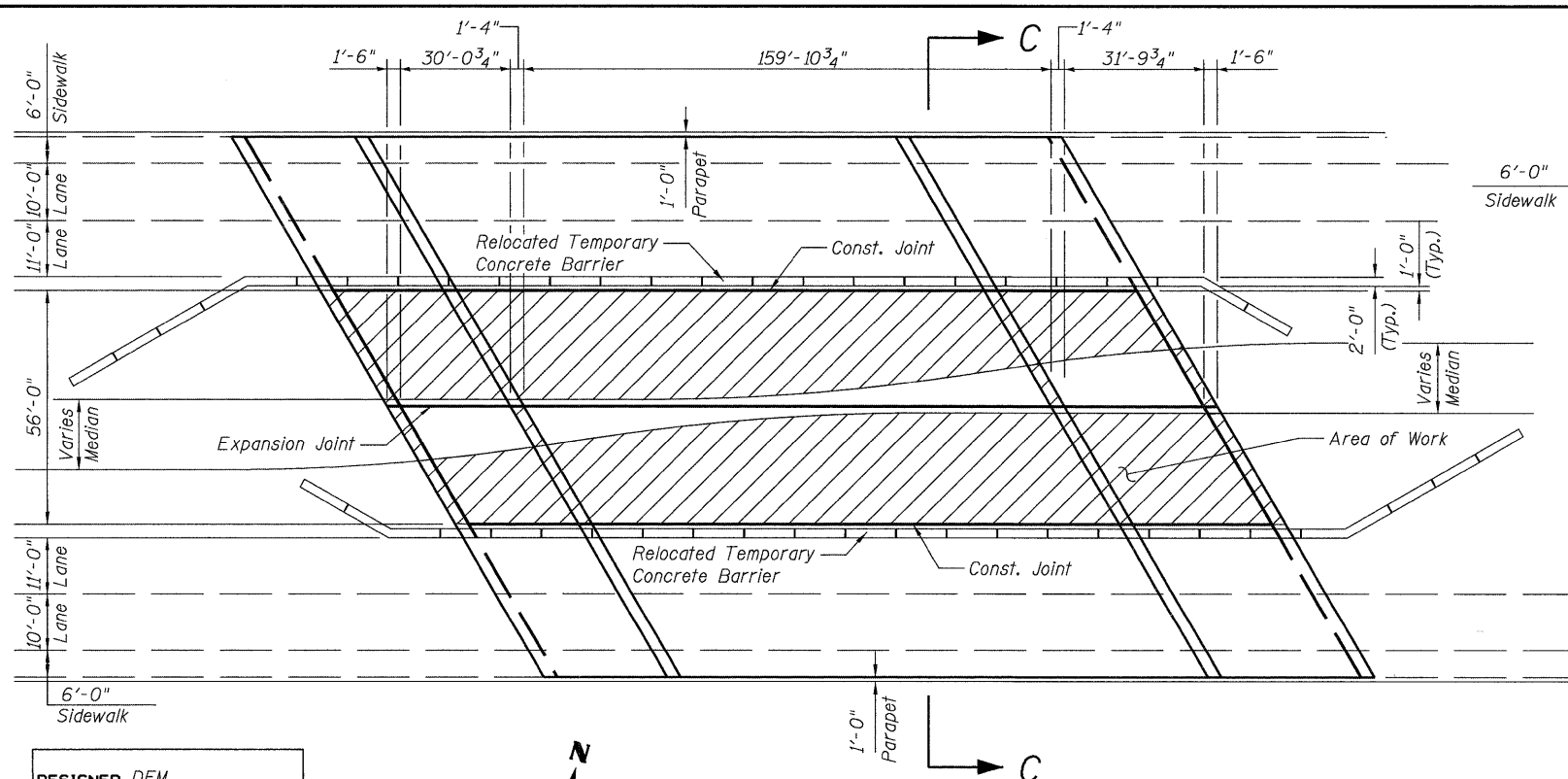

SECTION C-C

**STAGE II CONSTRUCTION**

Relocate temporary concrete barrier as shown. \*

Move traffic to Stage II traffic lanes.

Remove concrete wearing surface.

Replace bridge joints.

Install new wearing surface & waterproofing membrane.

Remove temporary concrete barrier.

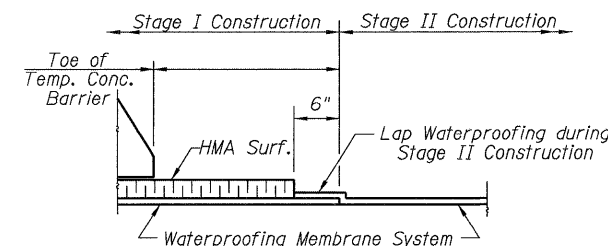

WATERPROOFING TREATMENT  
AT STAGE CONSTRUCTION

**STAGING PLAN**  
23RD AVE. OVER F.A.I. 74  
ROCK ISLAND COUNTY  
STRUCTURE NO. 081-0105

DESIGNED	DFM
CHECKED	DFM
DRAWN	EBS
CHECKED	DFM

STATE OF ILLINOIS  
DEPARTMENT OF TRANSPORTATION

ROUTE NO.	SECTION	COUNTY	TOTAL SHEETS	SHEET NO.	SHEET NO. 3
FAI 74	*	ROCK ISLAND	246	190	11 SHEETS
FED. ROAD DIST. NO. 7	ELLIPSES	FED. AID PROJECT-			

\* 81 (1-2, 1, 2-2) RS-1 & M

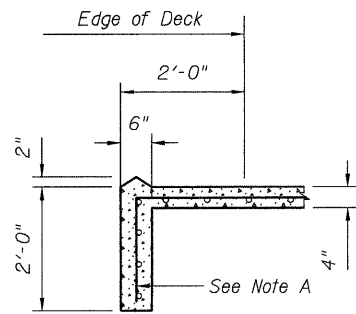

SECTION A-A

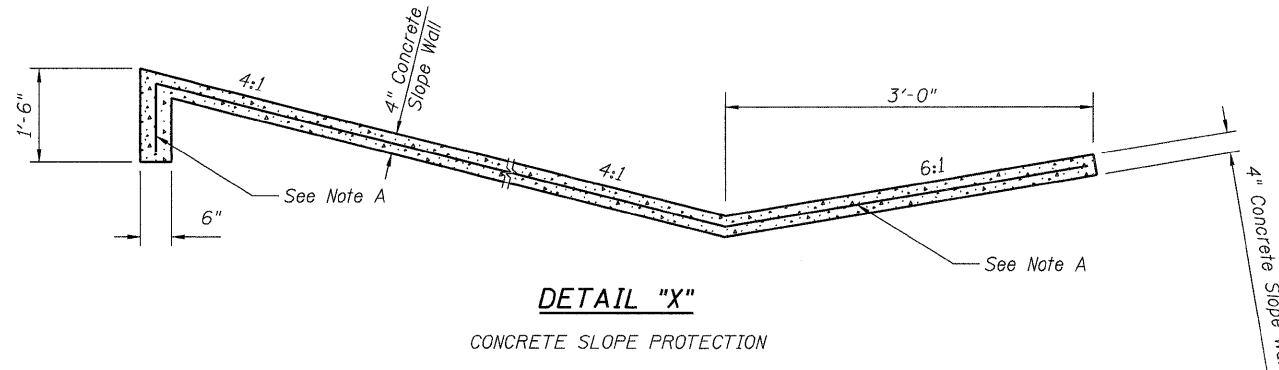

DETAIL "X"  
CONCRETE SLOPE PROTECTION

Note A:  
Sloped wall shall be reinforced with welded wire fabric, 6" x 6" - W 4.0 x W 4.0, weighing 58 pounds per 100 Sq. Ft., included in contract unit price for Sloped wall (4 inch).

Quantities for sidewalk repair are approximate. Locations will be determined by the Resident Engineer during Stage I Construction. Actual repair locations shall be shown on as-built plans. Contractor will be paid for the quantity furnished.

BILL OF MATERIAL

ITEM	UNIT	QUANTITY
Polymerized HMA Surface Course Mix "E", N90	TON	348
Protective Shield	SQ. YD.	1179
Waterproofing Membrane System	SQ. YD.	2340
Bridge Deck Scarification	SQ. YD.	2330
Deck Slab Repair (Full Depth Type II)	SQ. YD.	3
Deck Slab Repair (Partial Depth)	SQ. YD.	27

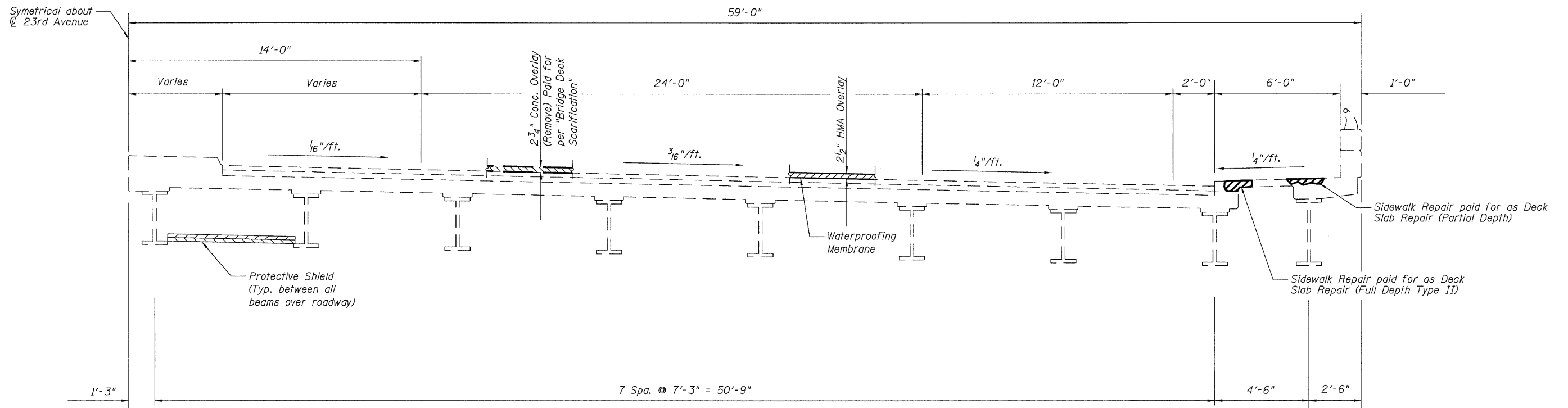

HALF CROSS SECTION  
(Looking West)

DESIGNED	DFM
CHECKED	DFM
DRAWN	EBS
CHECKED	DFM

BRIDGE REPAIR DETAILS  
23RD AVE. OVER F.A.I. 74  
ROCK ISLAND COUNTY  
STRUCTURE NO. 081-0105

STATE OF ILLINOIS  
DEPARTMENT OF TRANSPORTATION

ROUTE NO.	SECTION	COUNTY	TOTAL SHEETS	SHEET NO.	SHEET NO. 4
FAI 74	*	ROCK ISLAND	246	191	11 SHEETS
FED. ROAD DIST. NO. 7	ILLINOIS	FED. AID PROJECT-			

\* B1 (1-2, 1, 2-2) RS-1 & M

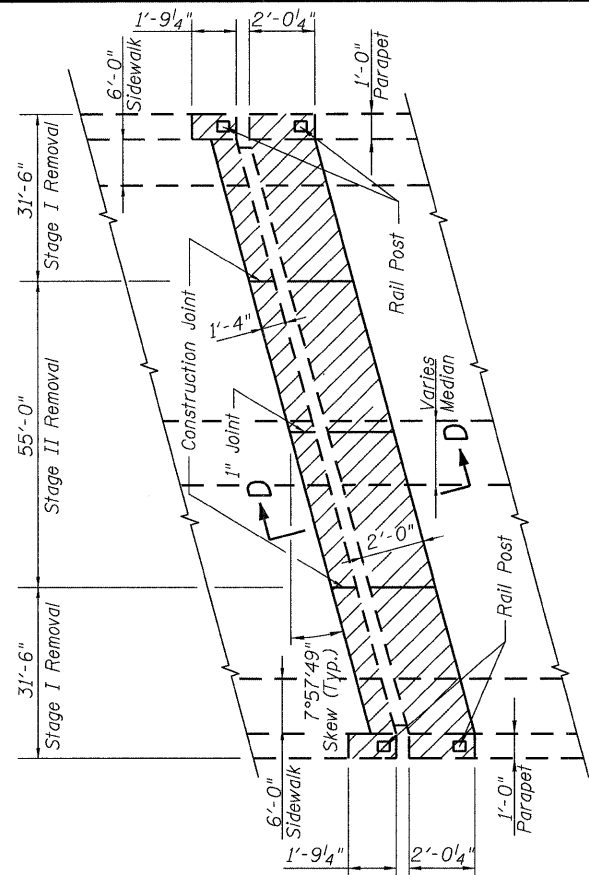

EXISTING PARTIAL PLAN -  
WEST ABUTMENT EXPANSION JOINT

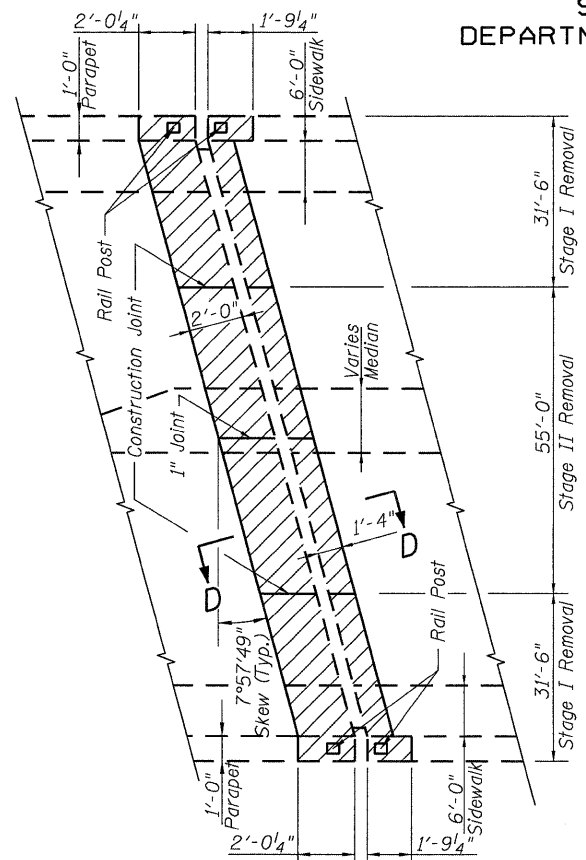

EXISTING PARTIAL PLAN -  
EAST ABUTMENT EXPANSION JOINT

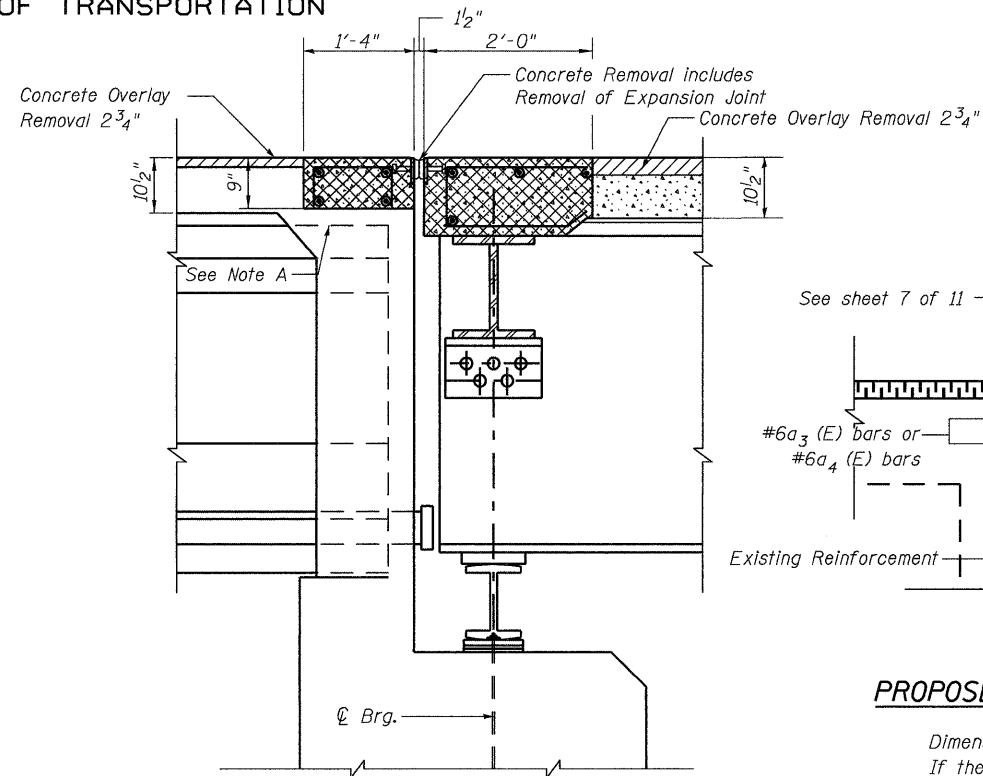

EXISTING SECTION D-D THRU ABUTMENTS

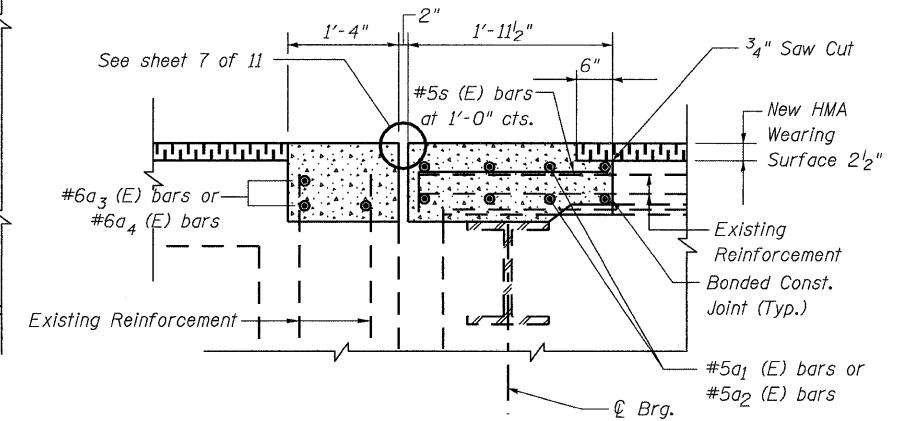

PROPOSED SECTION D-D THRU ABUTMENTS

Dimensions are based on a Rolled Rail Strip Seal Joint. If the contractor elects to use the Welded Rail Strip Seal Joint, deck dimensions may require adjustments to satisfy the details on Sheet 7 of 11.

BILL OF MATERIAL

BAR	NO.	SIZE	LENGTH	SHAPE
a <sub>1</sub> (E)	32	#5	25'-4"	—
a <sub>2</sub> (E)	32	#5	27'-6"	—
a <sub>3</sub> (E)	12	#6	25'-4"	—
a <sub>4</sub> (E)	12	#6	27'-6"	—
s (E)	208	#5	2'-4"	┌
Reinforcement Bars Epoxy Coated			Pound	3220
Concrete Removal			Cu. Yd.	27.3
Concrete Superstructure			Cu. Yd.	27.3
Bar Splicer			Each	44

NOTE A: Contractor shall take care in removal of concrete deck as to not damage the prestressed concrete beams in the top of the vaulted abutment. Any damage will need to be repaired to the satisfaction of the Resident Engineer at the contractor's expense. No additional payment will be made. For bar splicer assembly details see sheet 8 of 11. For Rail Post Details see sheet 11 of 11. For additional notes see sheet 1 of 11. For Parapet, Sidewalk & Median reinforcement see sheet 6 of 11.

DESIGNED	DFM
CHECKED	DSG
DRAWN	EBS
CHECKED	DFM

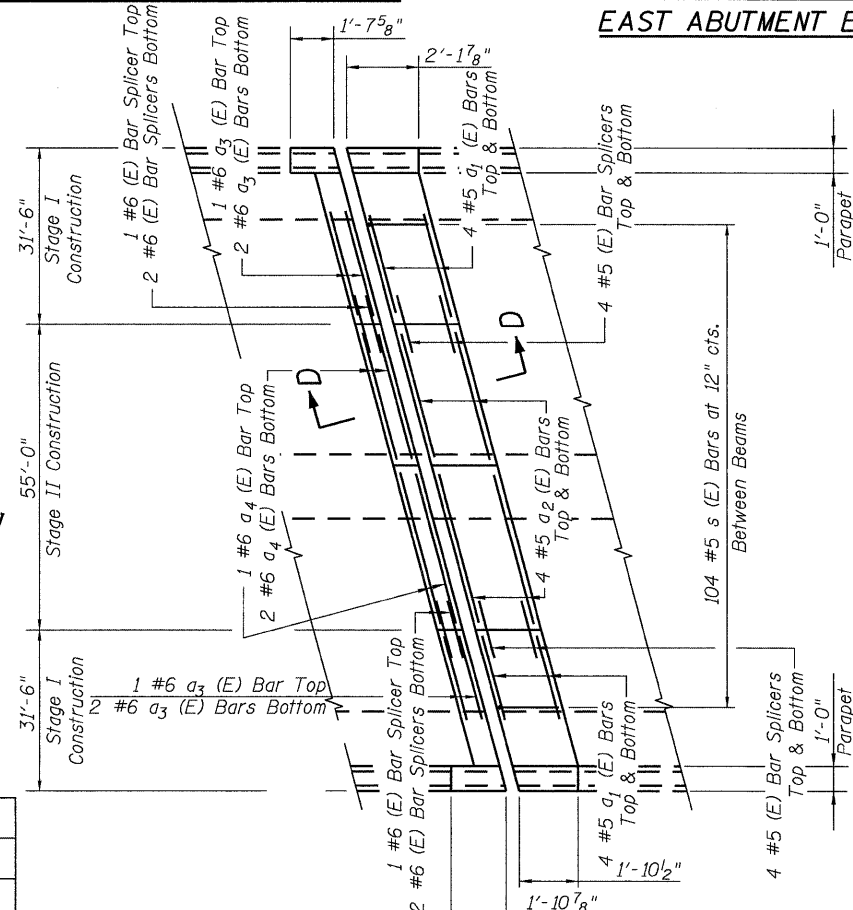

PROPOSED PARTIAL PLAN -  
WEST ABUTMENT EXPANSION JOINT

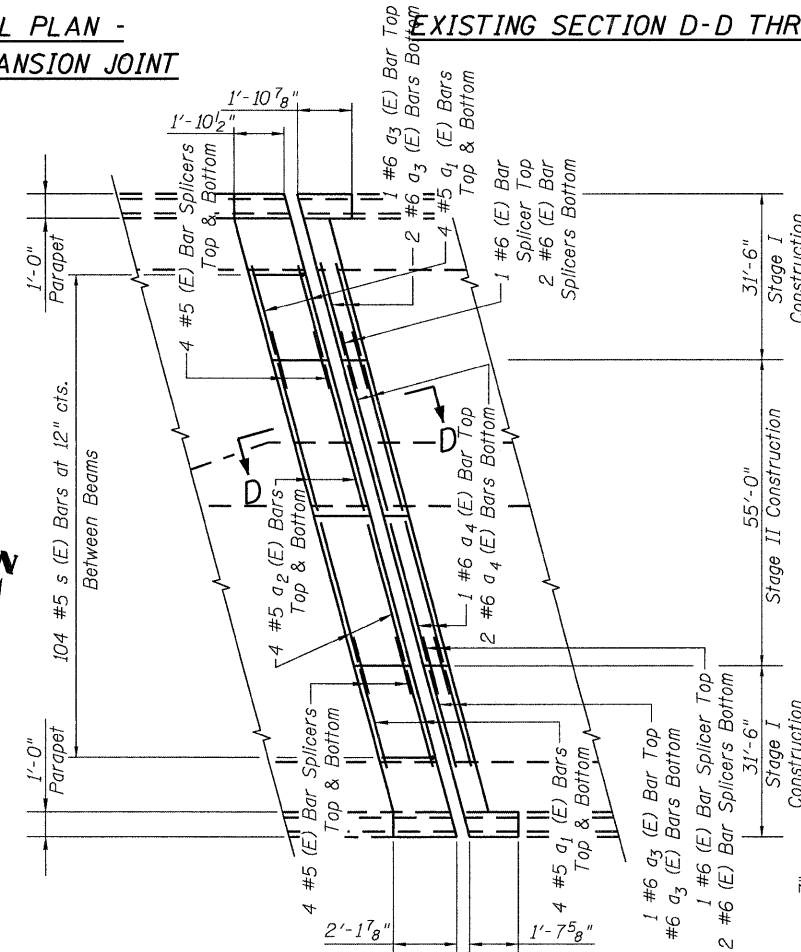

PROPOSED PARTIAL PLAN -  
EAST ABUTMENT EXPANSION JOINT

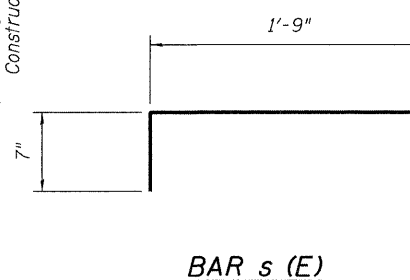

BAR s (E)

LEGEND

- Concrete Removal
- Concrete Superstructure

JOINT RECONSTRUCTION DETAILS  
23RD AVE. OVER F.A.I. 74  
ROCK ISLAND COUNTY  
STRUCTURE NO. 081-0105

STATE OF ILLINOIS  
DEPARTMENT OF TRANSPORTATION

ROUTE NO.	SECTION	COUNTY	SHEET NO.	SHEET	SHEET NO. 5
FAI 74	*	ROCK ISLAND	246	192	11 SHEETS
FED. ROAD DIST. NO. 7	ILLINOIS	FED. AID PROJECT-			

\* 81 (1-2, 1, 2-2) RS-1 & M

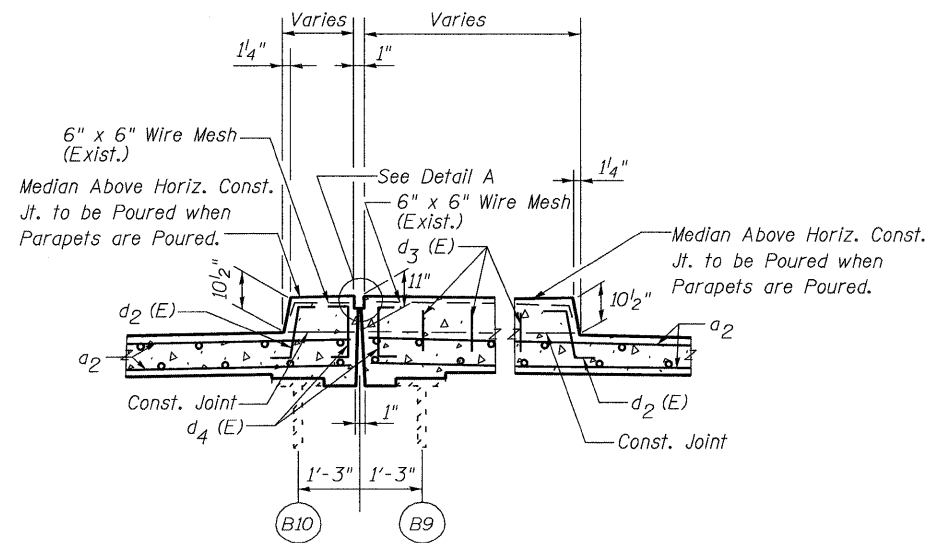

**MEDIAN SECTION E-E**

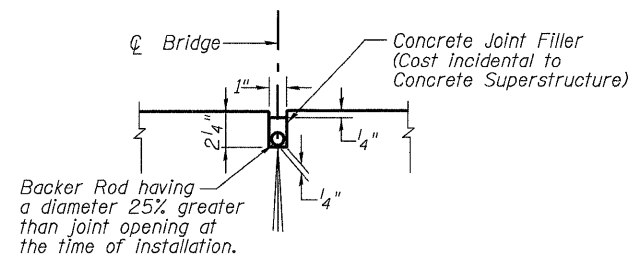

**DETAIL A**

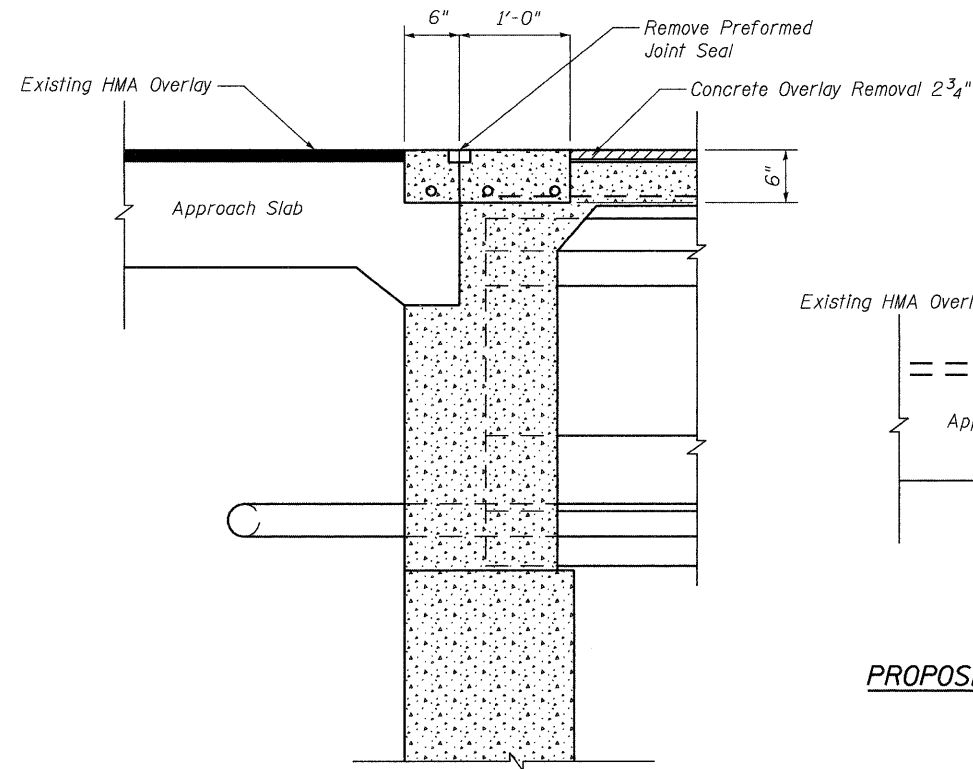

**EXISTING SECTION THRU APPROACH BENT**

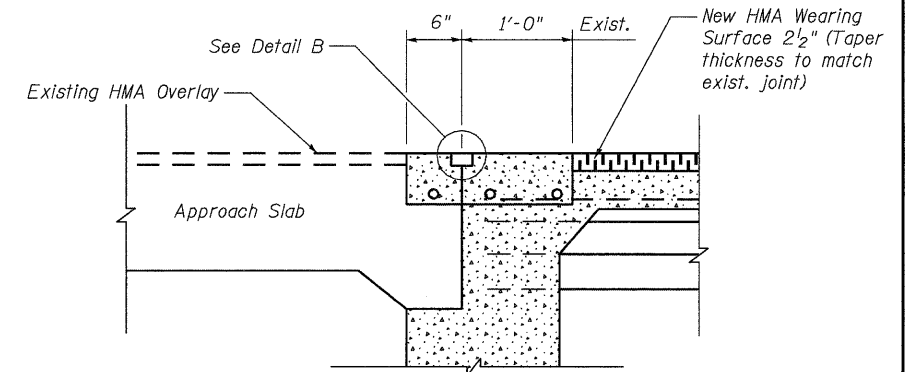

**PROPOSED SECTION THRU APPROACH BENTS**

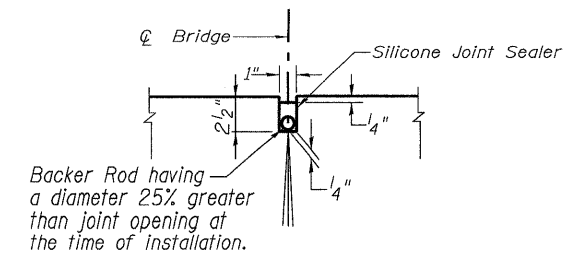

**DETAIL B**

For additional notes see sheet 1 of 11.

**LEGEND**

- Concrete Removal
- Concrete Superstructure

DESIGNED	DFM
CHECKED	DFM
DRAWN	EBS
CHECKED	DFM

**JOINT RECONSTRUCTION DETAILS**  
23RD AVE. OVER F.A.I. 74  
ROCK ISLAND COUNTY  
STRUCTURE NO. 081-0105

STATE OF ILLINOIS  
DEPARTMENT OF TRANSPORTATION

ROUTE NO.	SECTION	COUNTY	TOTAL SHEETS	SHEET NO.	SHEET NO. 6
FAI 74	*	ROCK ISLAND	246	193	11 SHEETS
FED. ROAD DIST. NO. 7	ILLINOIS	FED. AID PROJECT-	* 81 (1-2, 1, 2-2) RS-1 & M		

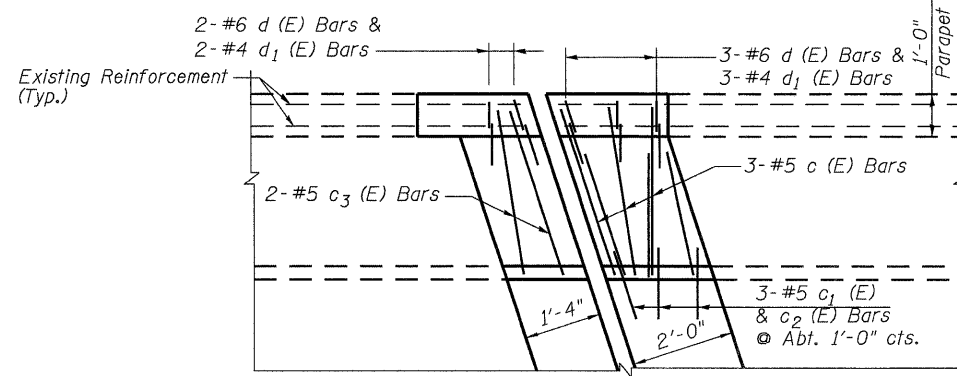

**NORTHWEST SIDEWALK PLAN AT EXPANSION JOINTS**

(Same reinforcing shall be used for the Southeast sidewalk)

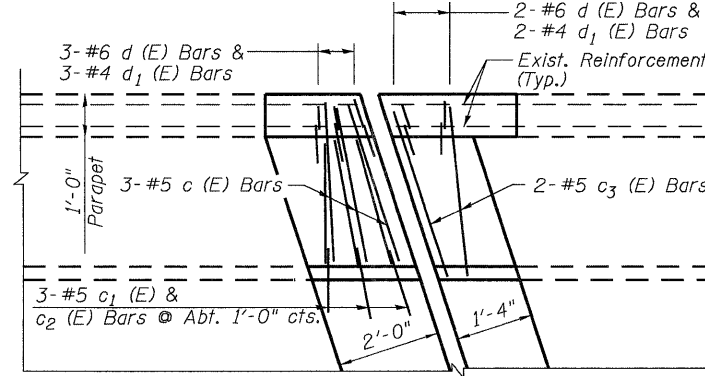

**NORTHEAST SIDEWALK PLAN AT EXPANSION JOINTS**

(Same reinforcing shall be used for the Southwest sidewalk)

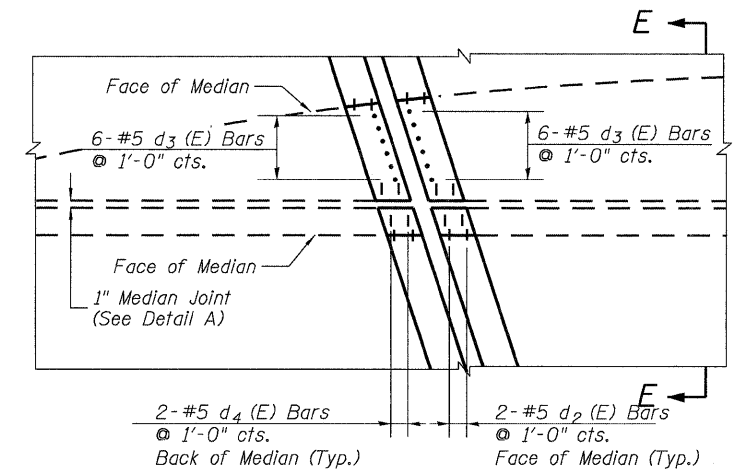

**EAST MEDIAN PLAN AT EXPANSION JOINT**

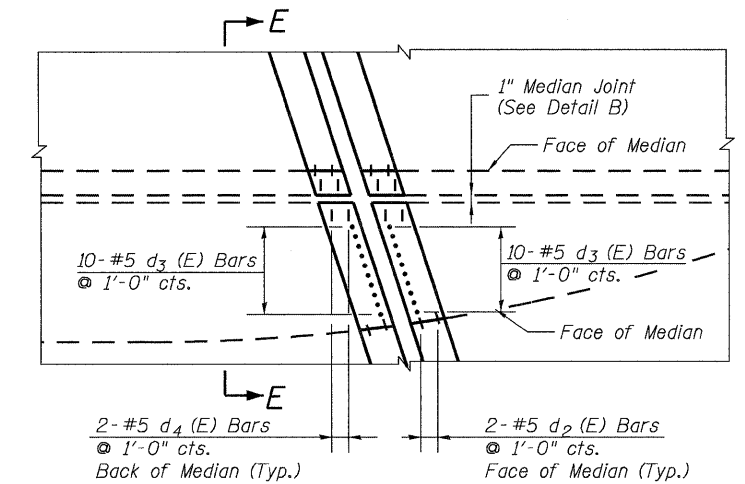

**WEST MEDIAN PLAN AT EXPANSION JOINT**

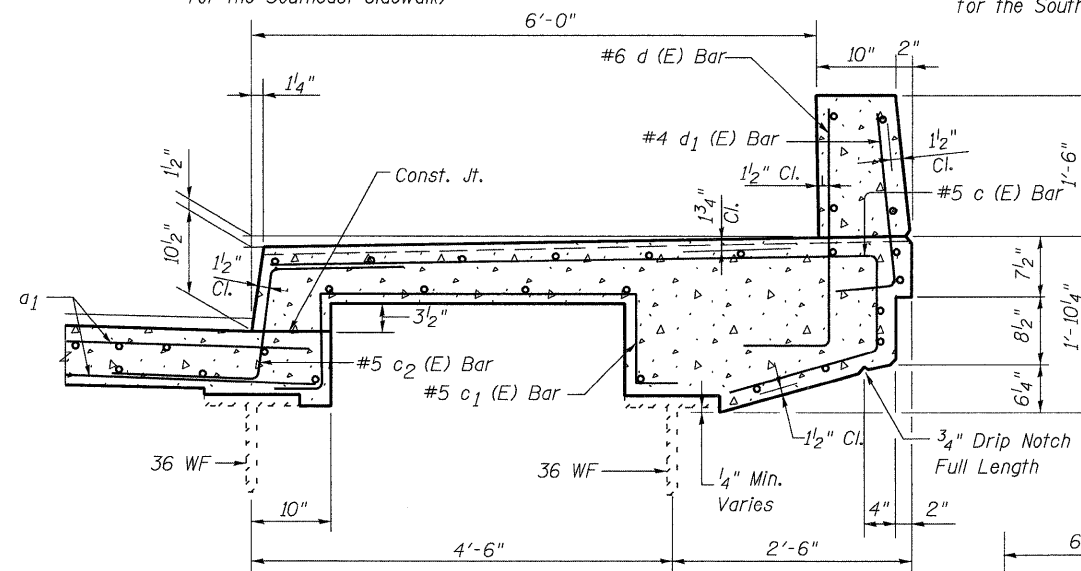

**WF BEAMS SIDEWALK SECTION AT EXPANSION JOINT**

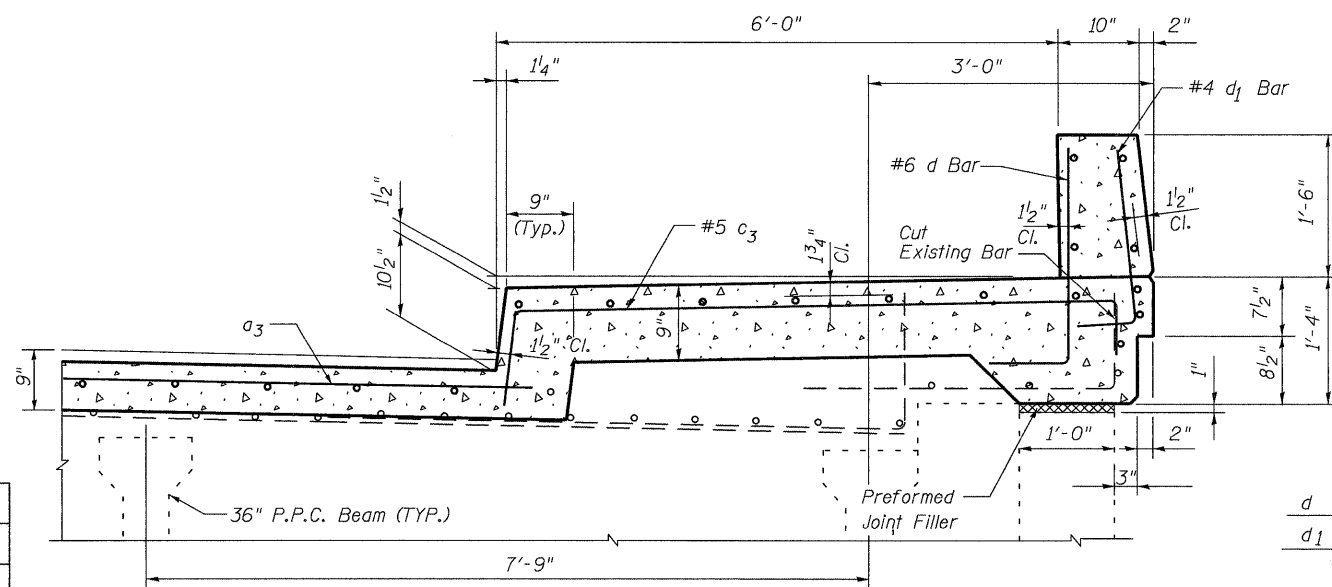

**AT PRESTRESSED BEAMS AT ABUTMENTS**

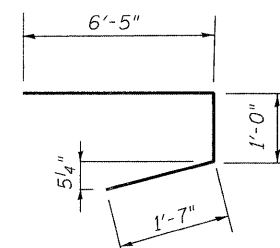

**BAR c (E)**

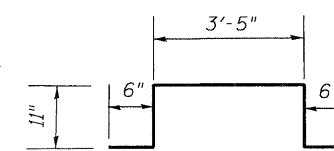

**BAR c1 (E)**

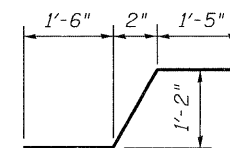

**BAR c2 (E)**

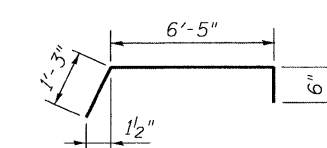

**BAR c3 (E)**

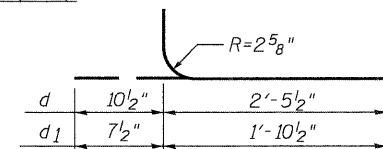

**BAR d (E) & d1 (E)**

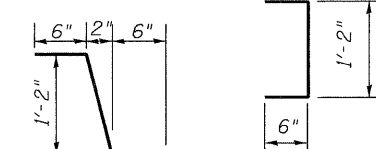

**BAR d2 (E) BAR d4 (E)**

**BILL OF MATERIALS**

BAR	NO.	SIZE	LENGTH	SHAPE
c (E)	12	#5	9'-0"	┌┐
c1 (E)	12	#5	6'-3"	┌┐
c2 (E)	12	#5	4'-1"	┌┐
c3 (E)	8	#5	8'-2"	┌┐
d (E)	20	#6	3'-4"	┌┐
d1 (E)	20	#4	2'-6"	┌┐
d2 (E)	16	#5	2'-2"	┌┐
d3 (E)	32	#5	1'-0"	┌┐
d4 (E)	16	#5	2'-2"	┌┐
Reinforcement Bars Epoxy Coated			Pound	550

For Section E-E see sheet 5 of 11.

**PARAPET, MEDIAN, AND SIDEWALK DETAILS**  
23RD AVE. OVER F.A.I. 74  
ROCK ISLAND COUNTY  
STRUCTURE NO. 081-0105

DESIGNED	DFM
CHECKED	DFM
DRAWN	EBS
CHECKED	DFM

STATE OF ILLINOIS  
DEPARTMENT OF TRANSPORTATION

ROUTE NO.	SECTION	COUNTY	TOTAL SHEETS	SHEET NO.	SHEET NO. 7
FAI 74	*	ROCK ISLAND	246	194	11 SHEETS
FED. ROAD DIST. NO. 7	ILLINOIS	FED. AID PROJECT-			

\*Granular or solid flux filled headed studs conforming to Article 1006.32 of the Std. Specs., automatically end welded.

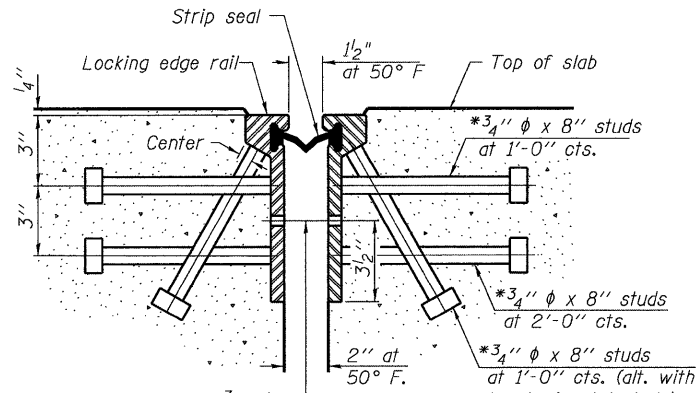

7/16"  $\phi$  holes at 4'-0" cts. for 3/8"  $\phi$  bolts. All bolts shall be burned, sawed, or chipped off flush with the plates after forms are removed, typ.

SECTION THRU ROLLED RAIL JOINT

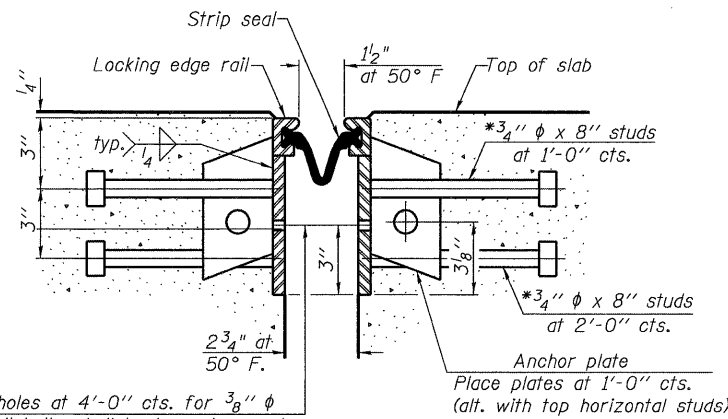

7/16"  $\phi$  holes at 4'-0" cts. for 3/8"  $\phi$  bolts. All bolts shall be burned, sawed, or chipped off flush with the plates after forms are removed, typ.

SECTION THRU WELDED RAIL JOINT

Notes:

The strip seal shall be made continuous and shall have a minimum thickness of 1/4". The configuration of the strip seal shall match the configuration of the Locking Edge Rails. Open or "webbed" strip seal gland configurations are not permitted. The gland shall be sized for a maximum rated movement of 4 inches.

The height and thickness of the Locking Edge Rails shown are minimum dimensions. The actual configuration of the Locking Edge Rails and matching strip seal may vary from manufacturer to manufacturer. Flanged edge rails will not be allowed. Locking Edge Rails may be spliced at slope discontinuities and stage construction joints.

The manufacturer's recommended installation methods shall be followed. The joint opening and deck dimensions detailed on the superstructure are based on a rolled rail expansion joint. If the Contractor elects to use the welded rail expansion joint, the opening and deck dimensions shall be modified according to the dimensions detailed on this sheet. Required modifications shall be made at no additional cost to the State.

All steel components shall be galvanized after fabrication according to Article 520.03 of the Standard Specifications.

\* B1 (1-2, 1, 2-2) RS-1 & M

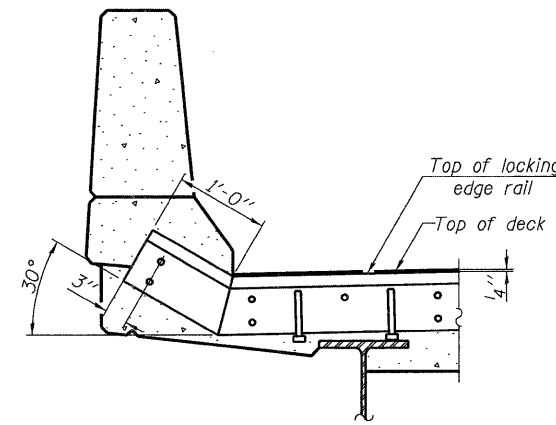

AT PARAPET

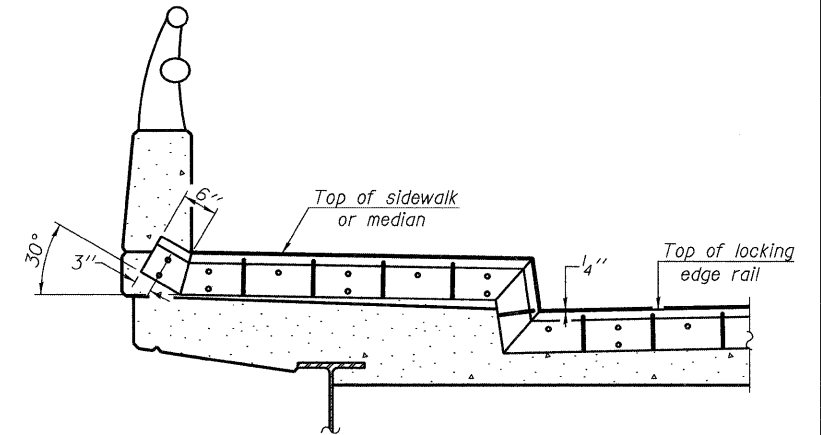

AT SIDEWALK OR MEDIAN

Shorter plates with a single row of studs at 12" cts. may be necessary on medians which are shallower than 9". See manufacturer's recommendation.

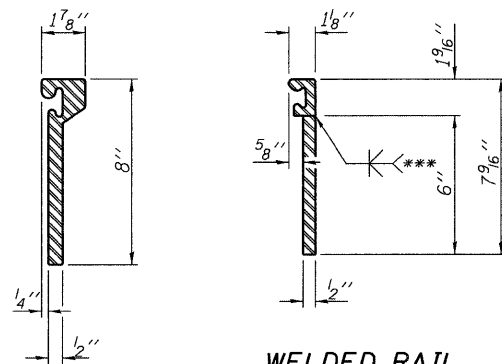

ROLLED EXTRUDED RAIL

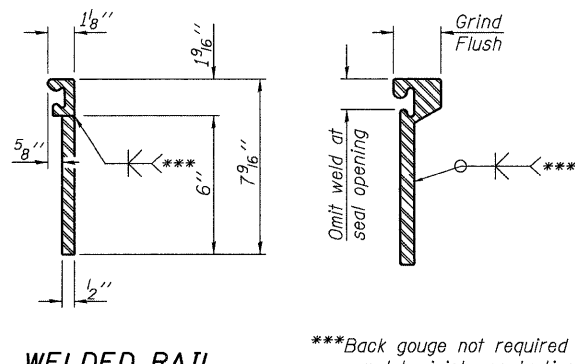

WELDED RAIL

\*\*\*Back gouge not required if complete joint penetration is verified by mock-up.

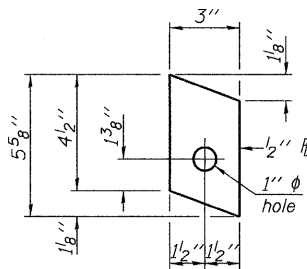

ANCHOR PLATE  
(for welded rail)

LOCKING EDGE RAIL SPLICE

The inside of the locking edge rail groove shall be free of weld residue.

LOCKING EDGE RAILS

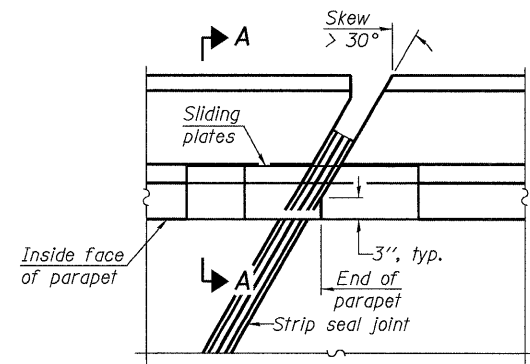

PLAN

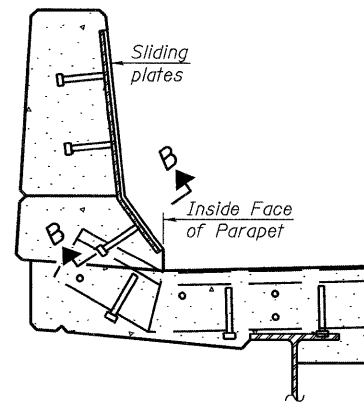

SECTION A-A

POINT BLOCK DETAILS  
(for skews > 30°)

TYPICAL END TREATMENTS

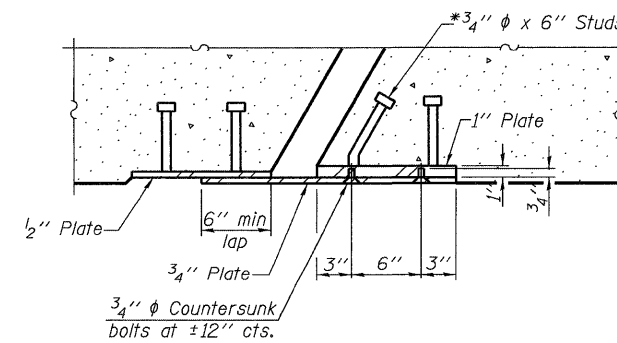

SECTION B-B

BILL OF MATERIAL

Item	Unit	Total
Preformed Joint Strip Seal	Foot	240

EXPANSION JOINT DETAILS  
23RD OVER F.A.I. 74  
ROCK ISLAND COUNTY  
STRUCTURE NO. 081-0105

DESIGNED	DFM
CHECKED	DSG
DRAWN	EBS
CHECKED	DFM

EJ-SSJ 5-16-08

STATE OF ILLINOIS  
DEPARTMENT OF TRANSPORTATION

ROUTE NO. FAI 74	SECTION *	COUNTY ROCK ISLAND	SHEET NO. 246	SHEET NO. 195	SHEET NO. 8 11 SHEETS
FED. ROAD DIST. NO. 7	ILLINOIS	FED. AID PROJECT-			

\* B1 (1-2, 1, 2-2) RS-1 & M

**NOTES**

Bar splicer assemblies shall be of an approved type and shall develop in tension at least 125 percent of the yield strength of the lapped reinforcement bars.  
Splicer rods shall be of minimum 60 ksi yield strength, threaded or coiled full length.  
All reinforcement bars shall be lapped and tied to the splicer rods or dowel bars.  
Bar splicer assemblies shall be epoxy coated according to the requirements for reinforcement bars.  
Other systems of similar design may be submitted to the Engineer for approval. Approval shall be based on certified test results from an approved testing laboratory that the proposed bar splicer assembly satisfies the following requirements:

- ① Minimum Capacity (Tension in kips) =  $1.25 \times f_y \times A_t$
- ② Minimum \*Pull-out Strength (Tension in kips) =  $0.66 \times f_y \times A_t$

Where  $f_y$  = Yield strength of lapped reinforcement bars in ksi.  
 $A_t$  = Tensile stress area of lapped reinforcement bars.  
\* = 28 day concrete

BAR SPLICER ASSEMBLIES			
Bar Size to be Spliced	Splicer Rod or Dowel Bar Length	Strength Requirements	
		Min. Capacity kips - tension	Min. Pull-Out Strength kips - tension
#4	1'-8"	14.7	7.9
#5	2'-0"	23.0	12.3
#6	2'-7"	33.1	17.4
#7	3'-5"	45.1	23.8
#8	4'-6"	58.9	31.3
#9	5'-9"	75.0	39.6
#10	7'-3"	95.0	50.3
#11	9'-0"	117.4	61.8

The diameter of this part is equal or larger than the diameter of bar spliced.

The diameter of this part is the same as the diameter of the bar spliced.

**ROLLED THREAD DOWEL BAR**



\*\* ONE PIECE

Wire Connector



**WELDED SECTIONS**

**BAR SPLICER ASSEMBLY ALTERNATIVES**

\*\*Heavy Hex Nuts conforming to ASTM A 563, Grade C, D or DH may be used.

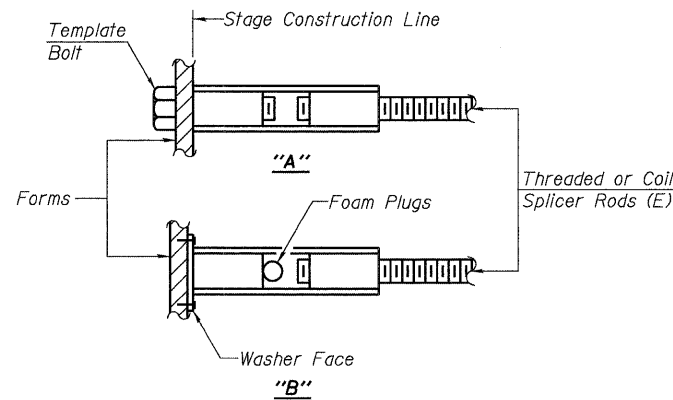

**INSTALLATION AND SETTING METHODS**

"A": Set bar splicer assembly by means of a template bolt.  
"B": Set bar splicer assembly by nailing to wood forms or cementing to steel forms.  
(E) : Indicates epoxy coating.

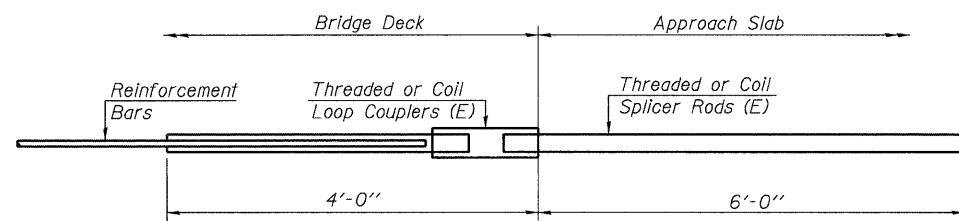

**FOR INTEGRAL OR SEMI-INTEGRAL ABUTMENTS**

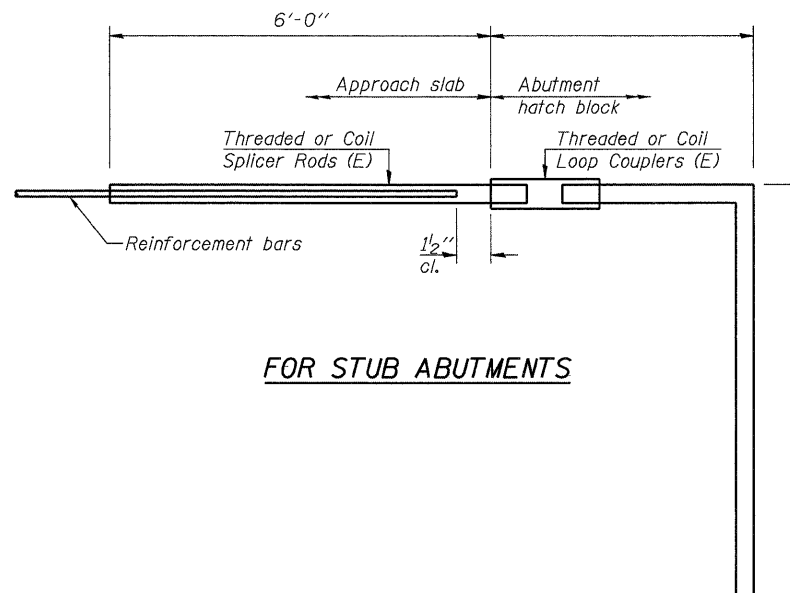

**FOR STUB ABUTMENTS**

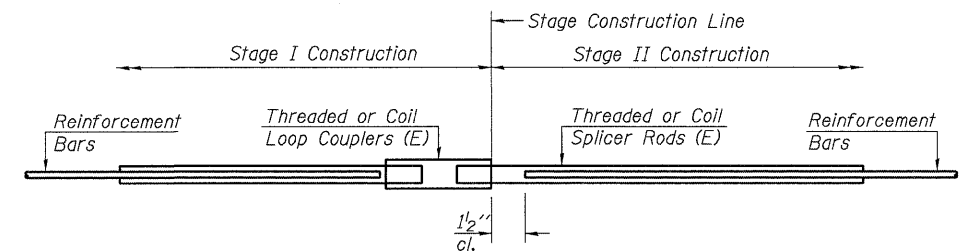

**STANDARD**

Bar Splicer for #5 bar
Min. Capacity = 23.0 kips - tension
Min. Pull-out Strength = 12.3 kips - tension
No. Required =

Bar Splicer for #5 bar
Min. Capacity = 23.0 kips - tension
Min. Pull-out Strength = 12.3 kips - tension
No. Required =

Bar Size	No. Assemblies Required	Location
#5	16	Bridge Deck at East Abutment
#5	16	Bridge Deck at West Abutment
#6	6	East Abutment
#6	6	West Abutment

DESIGNED DFM
CHECKED DSG
DRAWN EBS
CHECKED DFM

BSD-1 5-16-08

**BAR SPLICER ASSEMBLY DETAILS**  
23RD AVE. OVER F.A.I. 74  
ROCK ISLAND COUNTY  
STRUCTURE NO. 081-0105

STATE OF ILLINOIS  
DEPARTMENT OF TRANSPORTATION

ROUTE NO. FAI 74	SECTION *	COUNTY ROCK ISLAND	SHEET NO. 246	SHEET NO. 176	SHEET NO. 9 11 SHEETS
FED. ROAD DIST. NO. 7		ILLINOIS	FED. AID PROJECT-		

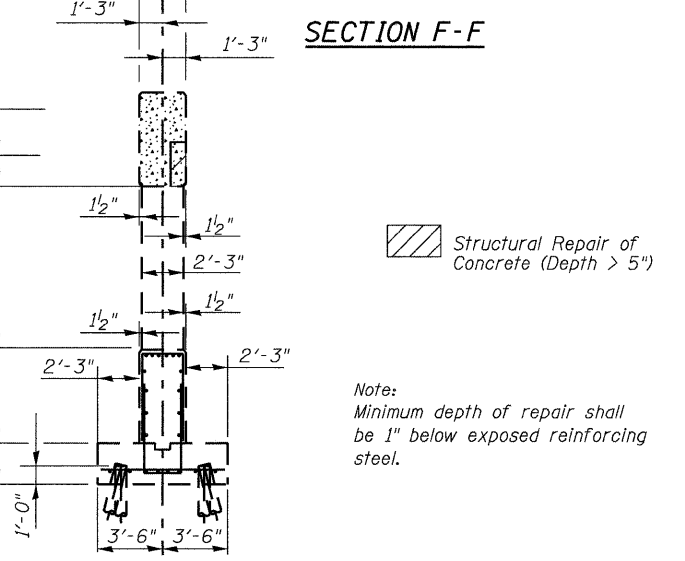
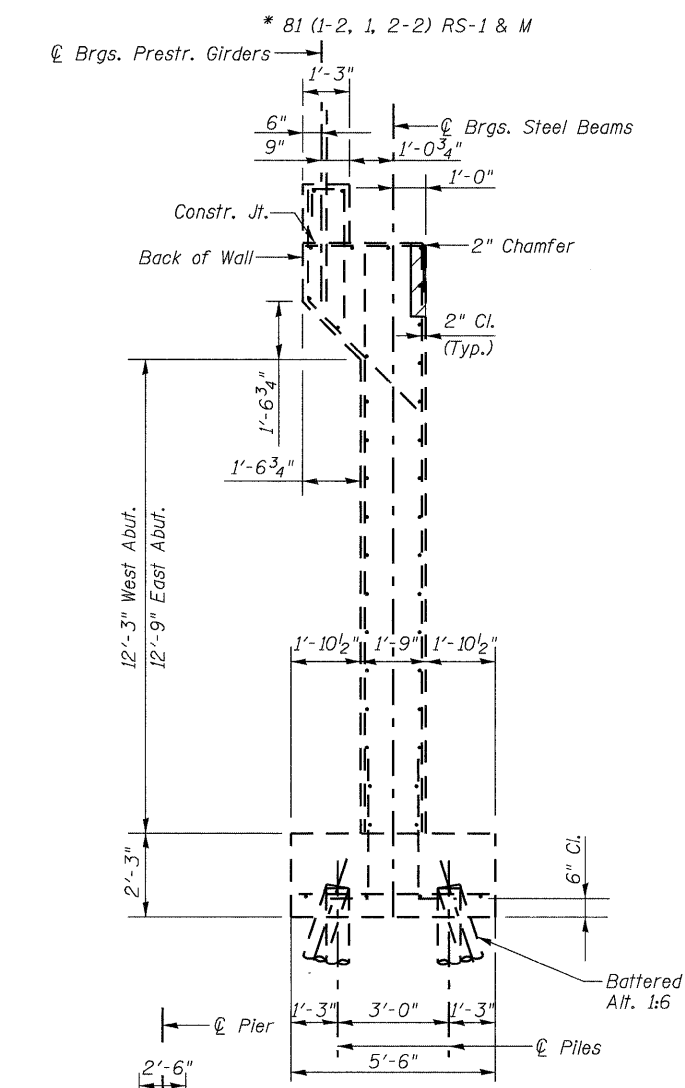
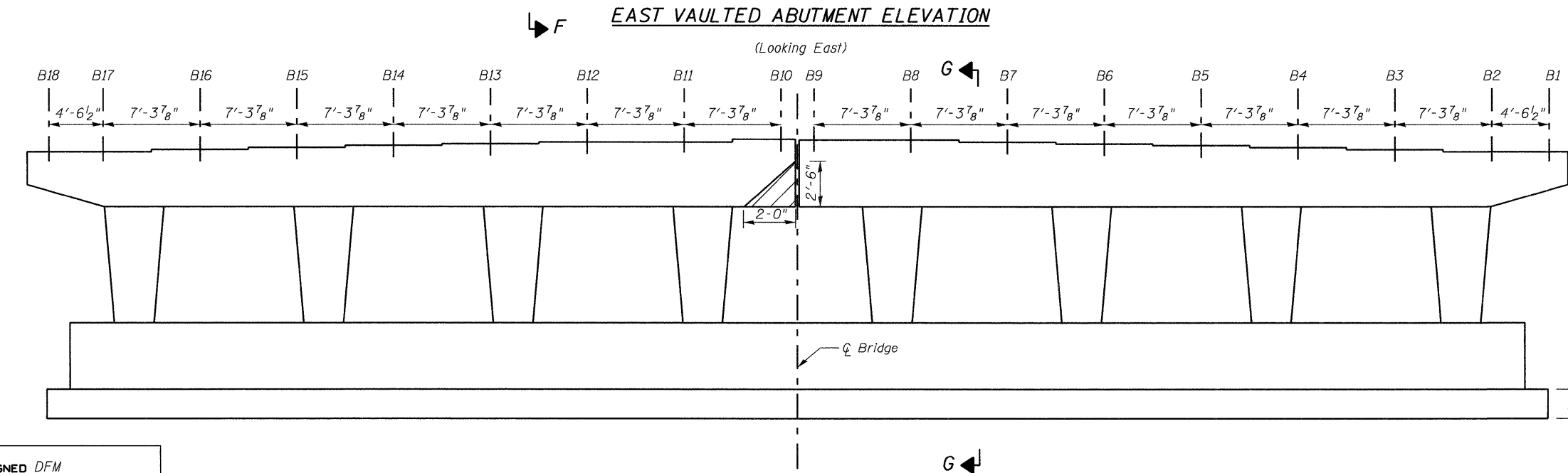
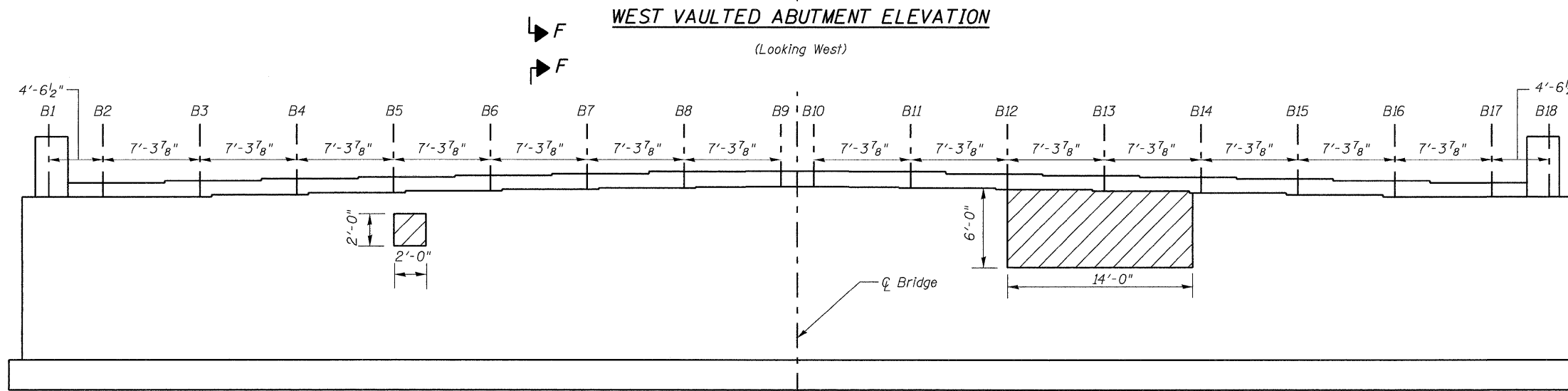
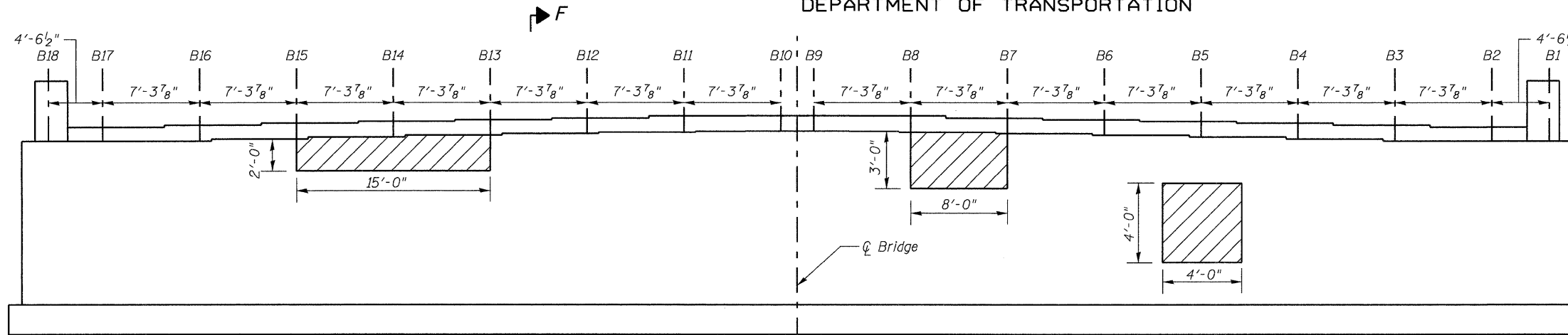

DESIGNED	DFM
CHECKED	DFM
DRAWN	EBS
CHECKED	DFM

**BILL OF MATERIAL**

ITEM	UNIT	QUANTITY
Structural Repair of Concrete (Depth > 5")	Sq. Ft.	162

**BRIDGE REPAIR DETAILS**  
23RD AVE. OVER F.A.I. 74  
ROCK ISLAND COUNTY  
STRUCTURE NO. 081-0105

Structural Repair of Concrete (Depth > 5")

Note:  
Minimum depth of repair shall be 1" below exposed reinforcing steel.



STATE OF ILLINOIS  
DEPARTMENT OF TRANSPORTATION

ROUTE NO.	SECTION	COUNTY	TOTAL SHEETS	SHEET NO.	SHEET NO. 10 11 SHEETS
FAI 74	*	ROCK ISLAND	246	197	
FED. ROAD DIST. NO. 7	ILLINOIS	FED. AID PROJECT-			

\* 81 (1-2, 1, 2-2) RS-1 & M

When "A" is 3'-6" or less, the temporary concrete barrier shall be anchored to the new slab according to Detail I or Detail II. No anchorage is required when "A" is greater than 3'-6".

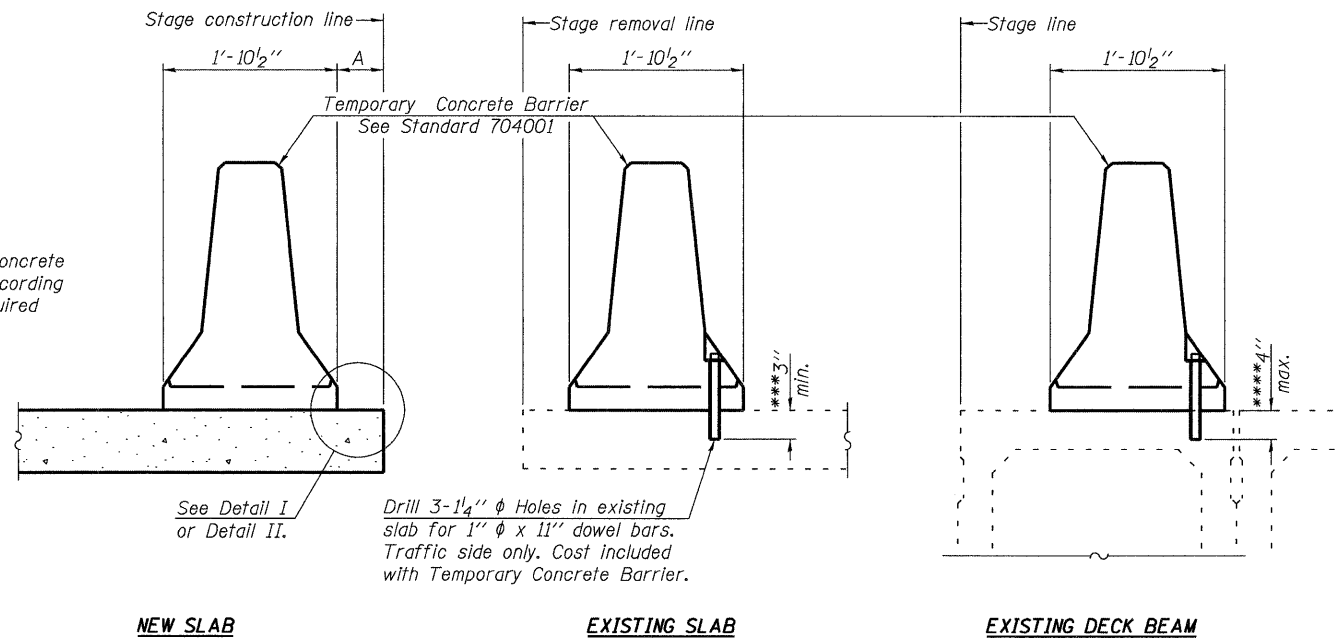

SECTIONS THRU SLAB OR DECK BEAM

NOTES

Detail I - With Bar Splicer or Couplers:  
Connect one (1) 1"x7"x10" steel PL to the top layer of couplers with 2-5/8" φ bolts screwed to coupler at approximate C of each barrier panel.

Detail II - With Extended Reinforcement Bars:  
Connect one (1) 1"x7"x10" steel PL to the concrete slab or concrete wearing surface with 2-5/8" φ Expansion Anchors or cast in place inserts spaced between the top layer of reinforcement at approximate C of each barrier panel.

Cost of anchorage is included with Temporary Concrete Barrier. The 1" x 7" x 10" plate shall not be removed until stage II construction forms and all reinforcement bars are in place and the concrete is ready to be placed.

\*\*\*Dimension shown is minimum required embedment into concrete. If hot-mix asphalt wearing surface is present, minimum embedment shall be in addition to wearing surface depth.

\*\*\*If existing deck beam is to remain in place after stage construction, embedment shall only be into wearing surface and not into existing deck beam concrete.

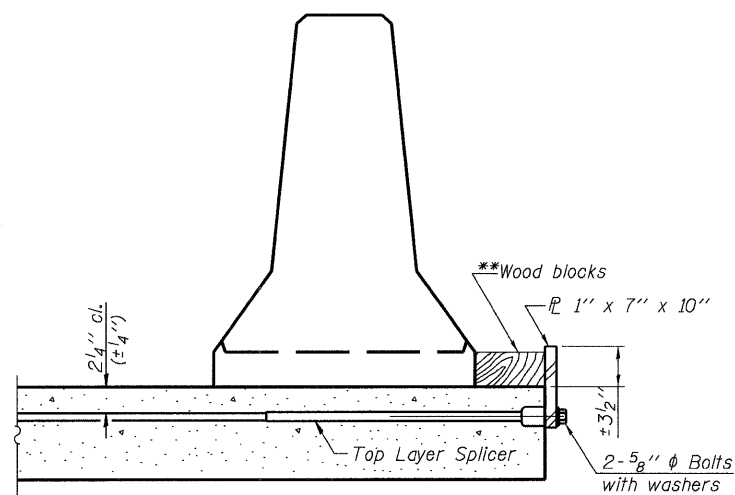

DETAIL I

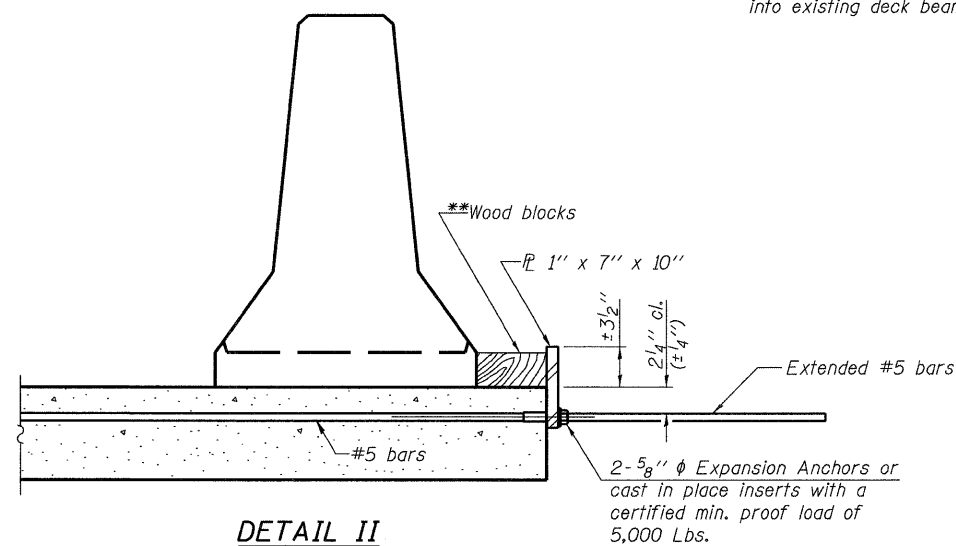

DETAIL II

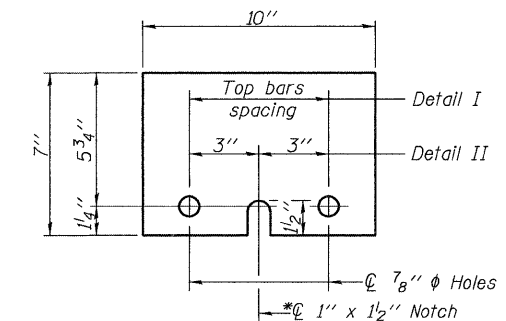

STEEL RETAINER PL 1" x 7" x 10"

\*Required only with Detail II

\*\*Wood blocks may be omitted when required to provide minimum stage traffic lane width. When the wood blocks are omitted, the concrete barrier shall be in direct contact with the steel retainer plate.

DESIGNED	DFM
CHECKED	DFM
DRAWN	EBS
CHECKED	DFM

R-27

5-16-08

TEMPORARY CONCRETE BARRIER  
FOR STAGE CONSTRUCTION  
23RD AVE. OVER F.A.I. 74  
ROCK ISLAND COUNTY  
STRUCTURE NO. 081-0105

STATE OF ILLINOIS  
DEPARTMENT OF TRANSPORTATION

ROUTE NO.	SECTION	COUNTY	TOTAL SHEETS	SHEET NO.	SHEET NO.
FAI 74	*	ROCK ISLAND	246	198	11 SHEETS
FED. ROAD DIST. NO. 7	ILLINOIS	FED. AID PROJECT-			

\* 81 (1-2, 1, 2-2) RS-1 & M

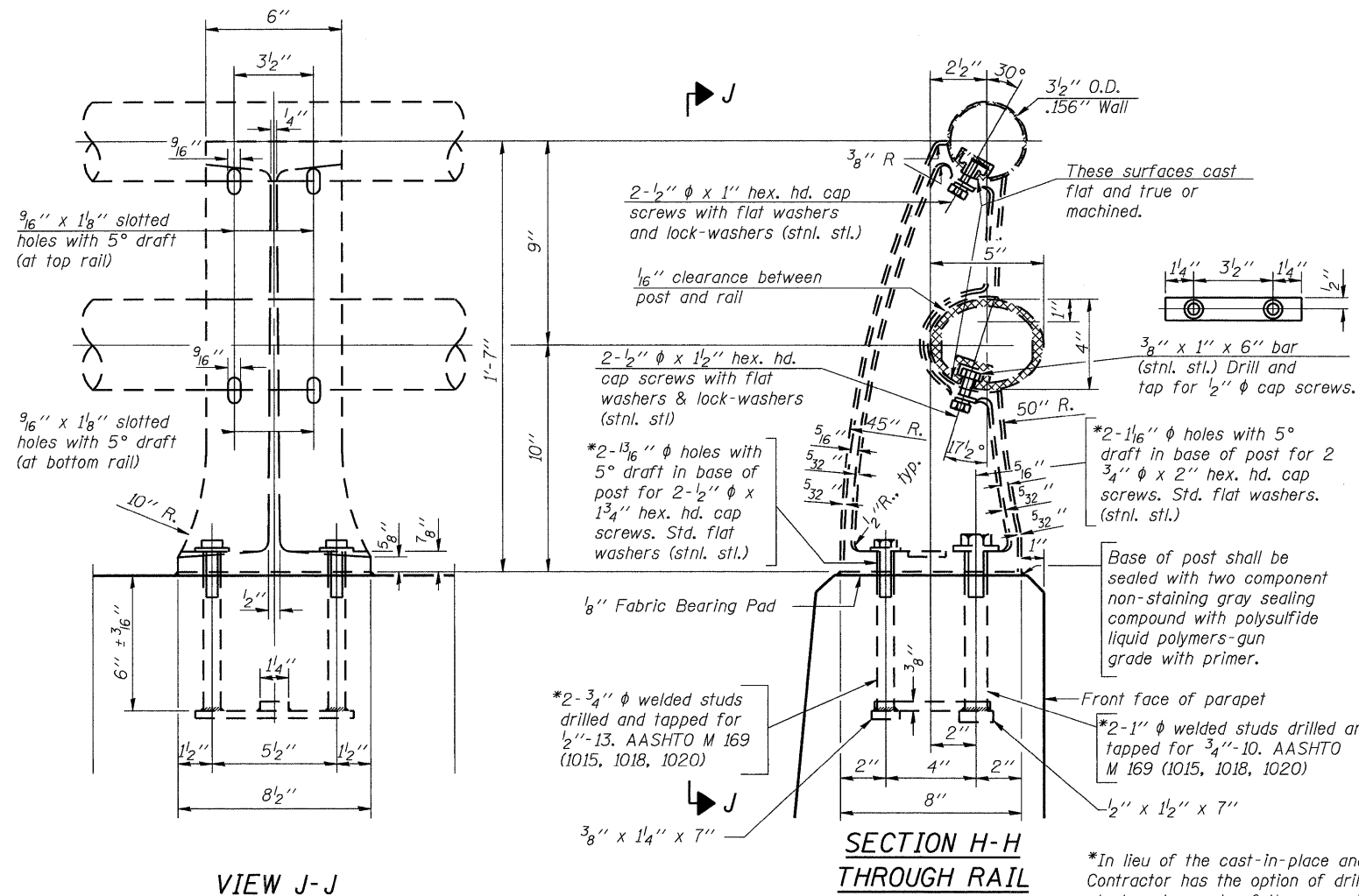

RAIL POST DETAILS

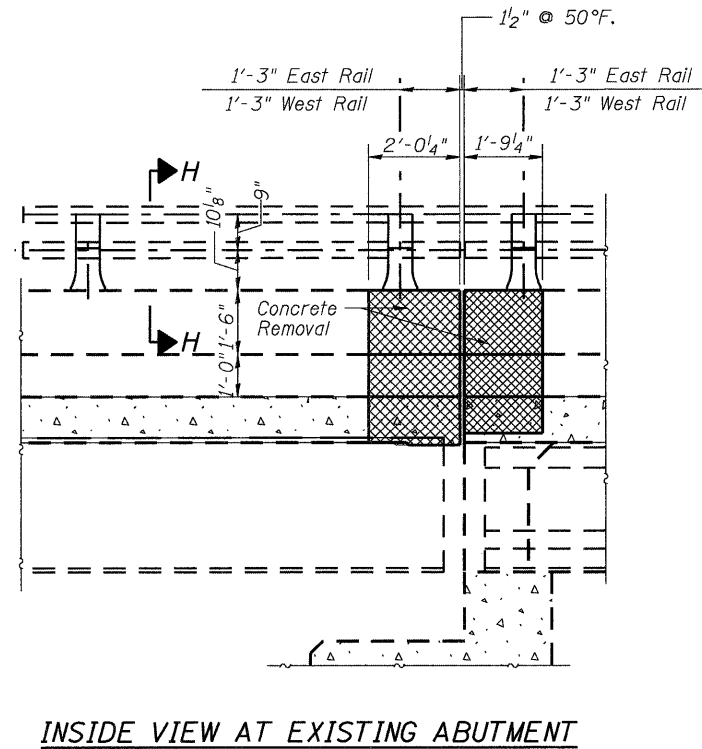

INSIDE VIEW AT EXISTING ABUTMENT

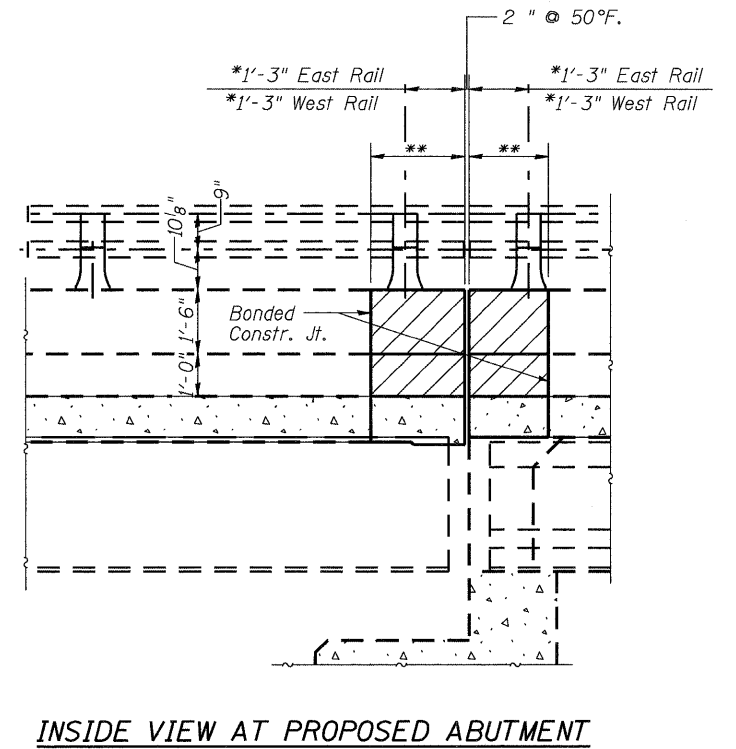

INSIDE VIEW AT PROPOSED ABUTMENT

\*In lieu of the cast-in-place anchor device shown, the Contractor has the option of drilling and setting stainless steel anchor rods of the same diameter and grade as the specified cap screws according to Article 509.06 of the Standard Specifications. Embedment shall be according to the manufacturer's specifications.

\*\* See sheet 4 of 12 for dimension.

Notes:  
For concrete removal limits See Sheet 4 of 12.  
Remove and reuse railing, including posts and anchors, where concrete removal affects existing rail posts. If anchors are damaged during construction, they shall be replaced and are included with concrete removal.  
Length of rail shall be adjusted as detailed with a flush cut and the cast end cap shall be reused.

DESIGNED	DFM
CHECKED	DFM
DRAWN	EBS
CHECKED	DFM

RAILING DETAILS  
23RD AVE. OVER F.A.I. 74  
ROCK ISLAND COUNTY  
STRUCTURE NO. 081-0105

STATE OF ILLINOIS  
DEPARTMENT OF TRANSPORTATION

ROUTE NO.	SECTION	COUNTY	TOTAL SHEETS	SHEET NO.	SHEET NO.
FAI 74	*	ROCK ISLAND	246	199	12 SHEETS
FED. ROAD DIST. NO. 7	ILLINOIS	FED. AID PROJECT-			

\* 81 (1-2, 1, 2-2) RS-1 & M

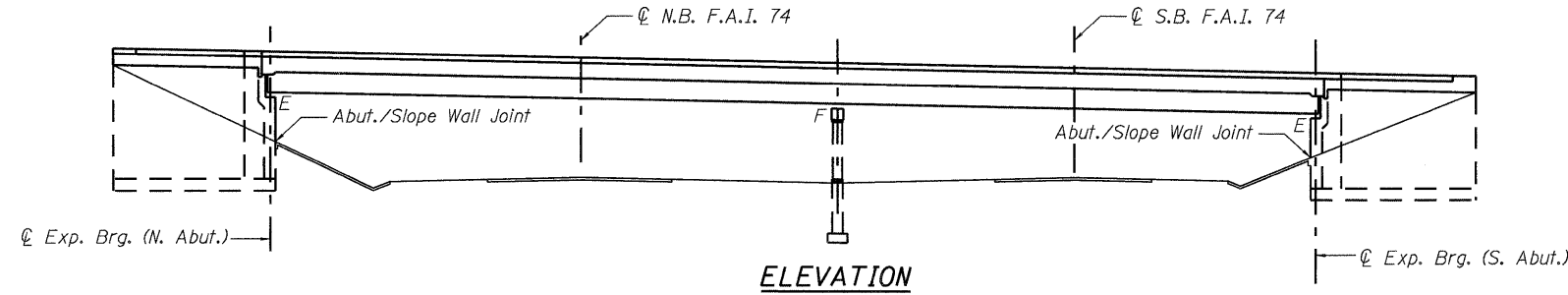

**GENERAL NOTES**

No field welding is permitted except as specified in the contract documents.

Existing reinforcement bars extending into the removal areas shall be cleaned, straightened and incorporated into the new construction. Any reinforcement bars that are damaged during concrete removal shall be replaced with approved bar splicer or anchoring system. Cost included with concrete removal.

Reinforcement bars shall conform to the requirements of ASTM A 706 Grade 60. See Special Provisions.

Reinforcement bars designated (E) shall be epoxy coated.

Plan dimensions and details relative to existing plans are subject to nominal construction variations. The Contractor shall field verify existing dimensions and details affecting new construction and make necessary approved adjustments prior to construction or ordering of materials. Such variations shall not be cause for additional compensation for a change in scope of work, however, the Contractor will be paid for the quantity actually furnished at the unit price bid for the work.

Layout of proposed slope protection system may be varied to suit ground conditions in the field as directed by the Engineer.

Prior to pouring the new concrete deck, all heavy or loose rust, loose mill scale, and all other loose, potentially detrimental foreign material shall be removed from the surfaces in contact with concrete. Tightly adhered paint may remain unless otherwise noted. Removal shall be accomplished by methods that will not damage the steel and the cost will be included in the pay item covering removal of the existing concrete.

The existing structural steel coating contains lead. The contractor shall take appropriate precautions to deal with the presence of lead on this project.

Joint openings shall be adjusted according to article 520.04 of the standard specifications when the deck is poured of an ambient temperature other than 50° F.

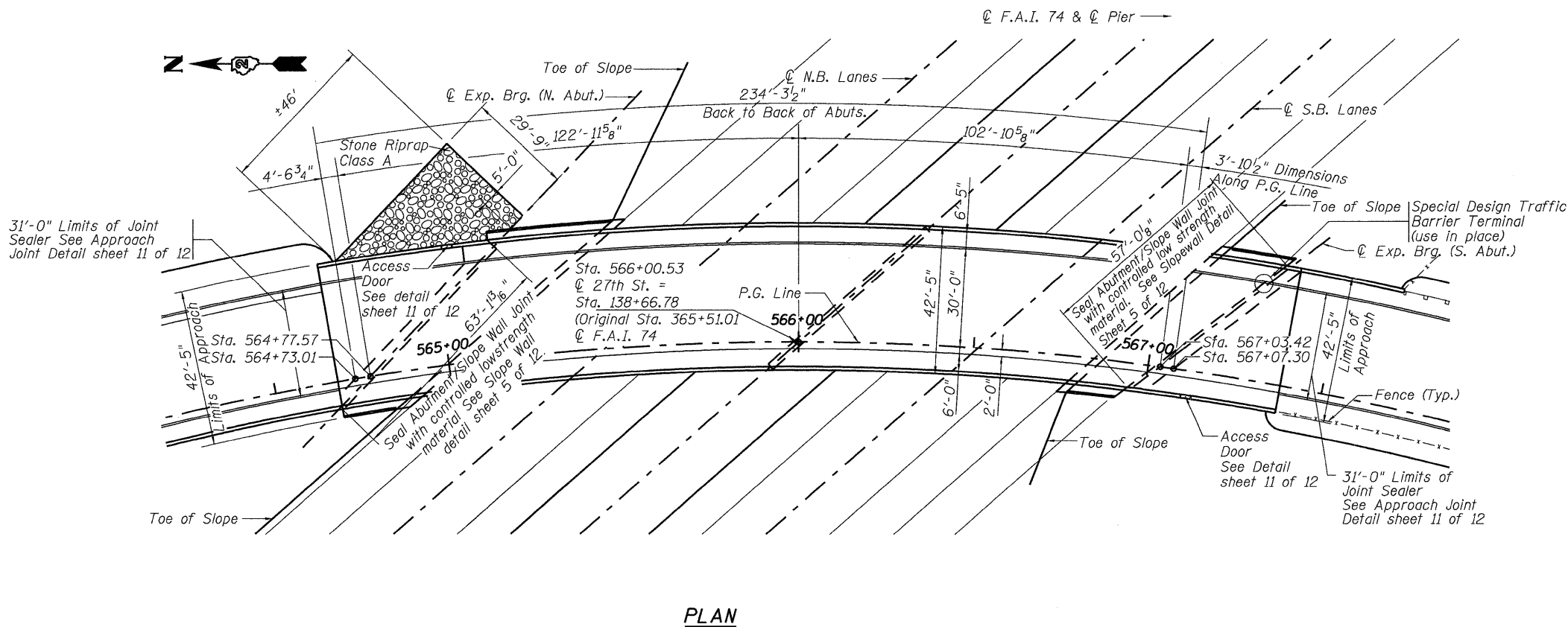

**TOTAL BILL OF MATERIAL**

ITEM	UNIT	QUANTITY
Stone Riprap, Class A1	SQ. YD.	29.9
Concrete Removal	CU. YD.	17.6
Concrete Superstructure	CU. YD.	17.6
Reinforcement Bars, Epoxy Coated	POUND	2170
Bar Splicers	EACH	22
Controlled Low Strength Material	CU. YD.	1
Preformed Joint Strip Seal	FOOT	112
Silicone Joint Sealer	FOOT	14
Access Door	EACH	2
Joint Sealer	FOOT	62

DESIGNED	DFM
CHECKED	DSG
DRAWN	EBS
CHECKED	DFM

DAVID F. MAXWELL  
081-005455  
ST. LOUIS, MO.

My registration expires November 30, 2010.

**PLAN AND ELEVATION**  
**N.B. 27TH ST. OVER F.A.I. 74**  
**ROCK ISLAND COUNTY**  
**STRUCTURE NO. 081-0108**

STATE OF ILLINOIS  
DEPARTMENT OF TRANSPORTATION

ROUTE NO.	SECTION	COUNTY	TOTAL SHEETS	SHEET NO.	SHEET NO.
FAI 74	*	ROCK ISLAND	246	200	12 SHEETS
FED. ROAD CONST. NO. 7		ILLINOIS	FED. AID PROJECT-		

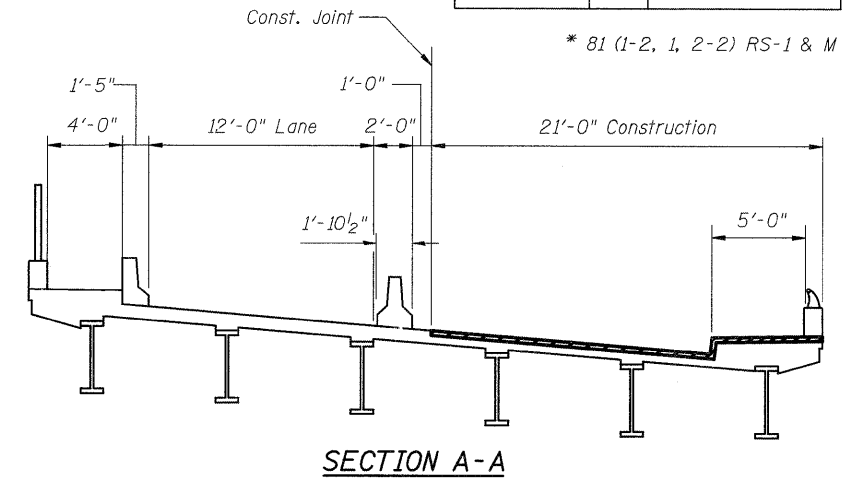
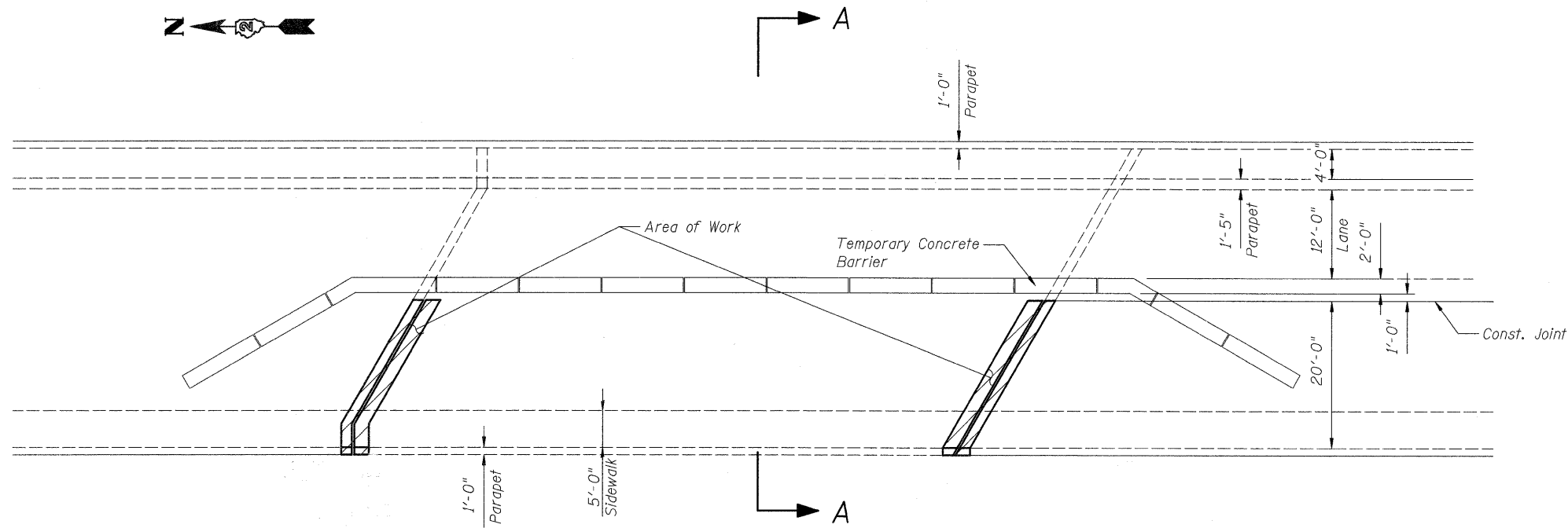

**STAGE I CONSTRUCTION**

- Install temporary concrete barrier as shown. \*
- Move traffic to Stage I traffic lane.
- Replace Bridge Joints & Seal Approach Joints.

\* For temporary concrete barrier details, see sheet 12 of 12.

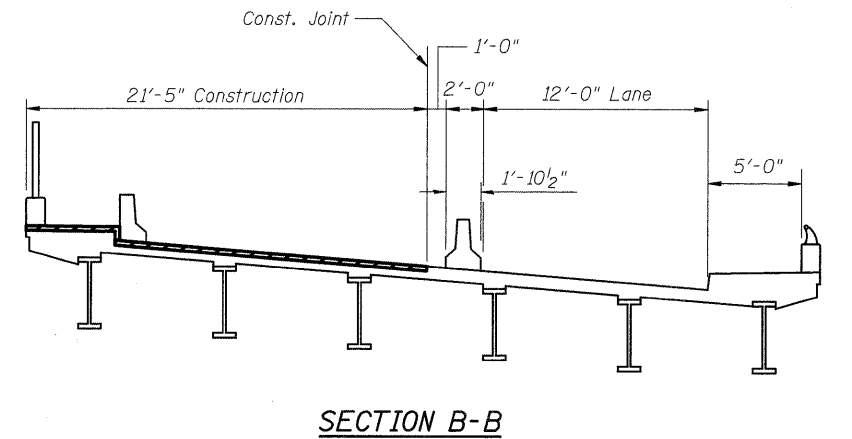
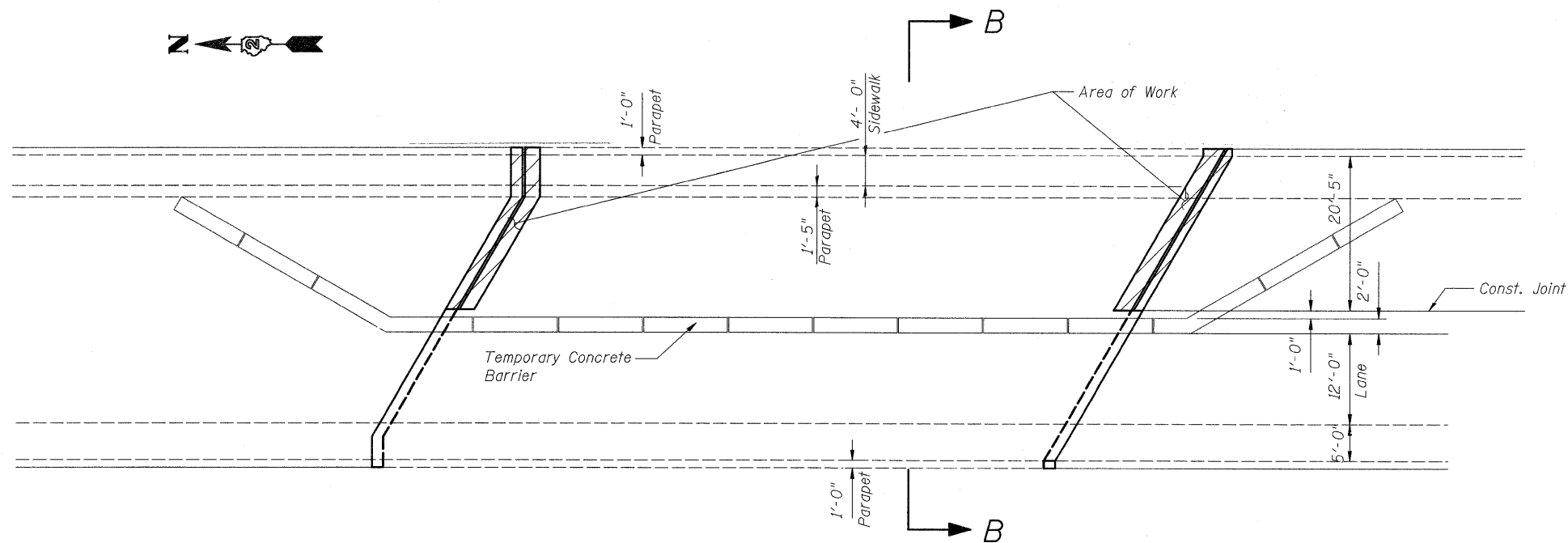

**STAGE II CONSTRUCTION**

- Relocate temporary concrete barrier as shown. \*
- Move traffic to Stage II traffic lane.
- Replace bridge joints & Seal Approach Joints.
- Remove temporary concrete barrier.

DESIGNED	DFM
CHECKED	DSG
DRAWN	EBS
CHECKED	DFM

**BRIDGE REPAIR DETAILS**  
**N.B. 27TH ST. OVER F.A.I. 74**  
**ROCK ISLAND COUNTY**  
**STRUCTURE NO. 081-0108**