

F.A.S. RTE.	SECTION	COUNTY	TOTAL SHEETS	SHEET NO.
294	.	MCLEAN	22	15

PROJECTS WITHOUT RECONSTRUCTION

S.M.A.R.T. IMPROVEMENTS
(POLICY RESURFACING; BDE 53-4.03; 1 1/2")

"3P" OR "3R" IMPROVEMENTS
(POLICY RESURFACING; BDE 53-4.02; 2 1/4" OR 2 1/2" ON BARE CONCRETE)

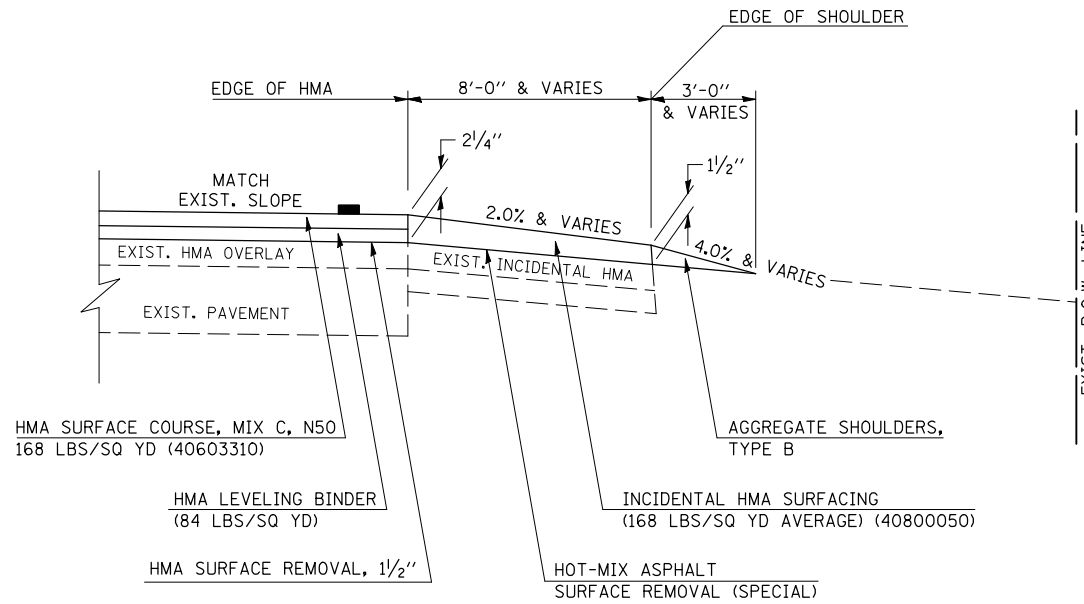
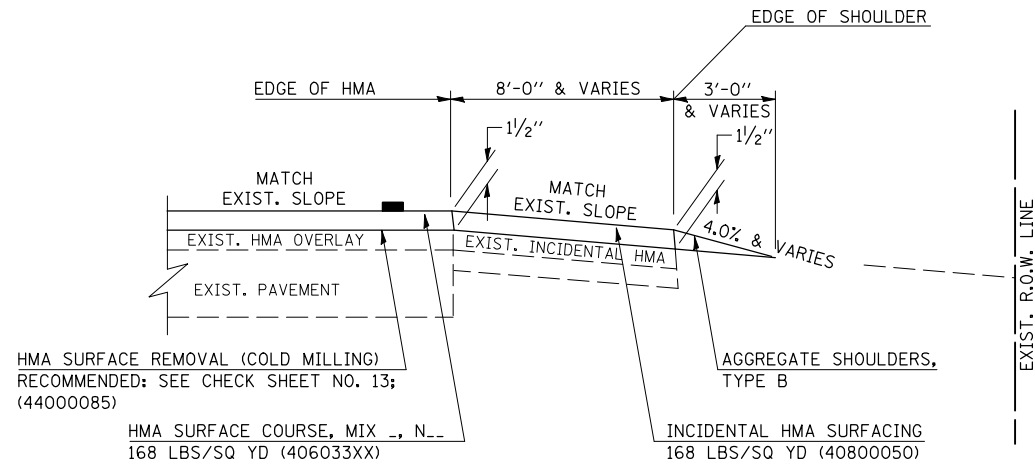

GENERAL NOTES

1. THE EXISTING SURFACE SHALL BE PREPARED IN ACCORDANCE WITH SECTION 408 OF THE STANDARD SPECIFICATIONS.
2. AGGREGATE BASE COURSE, TYPE B, 6" (150) MIN. SHALL BE USED WHERE IN THE OPINION OF THE ENGINEER THERE IS NOT SUFFICIENT BASE MATERIAL FOR THE PROPOSED MAILBOX TURNOUTS. THIS MATERIAL SHALL GENERALLY BE USED TO WIDEN ALL EXISTING MAILBOX TURNOUTS OR TO CONSTRUCT NEW MAILBOX TURNOUTS WHERE NONE NOW EXISTS.
3. ANY NECESSARY WORK BEHIND THE INCIDENTAL HMA SURFACING SHALL BE AS SHOWN IN THE PLANS AND/OR AS DIRECTED BY THE ENGINEER.
4. THE TEMPORARY RELOCATION OF EXISTING MAILBOXES SHALL BE IN ACCORDANCE WITH ARTICLE 107.20 OF THE STANDARD SPECIFICATIONS.
5. WHEN MORE THAN ONE RELOCATED MAILBOX IS INCLUDED IN A PARTICULAR LOCATION THE TWO 10' (3 m) DIMENSIONS AS SHOWN ABOVE SHALL BE FROM THE END MAILBOX.
6. CROSS SLOPE SHALL BE AS SHOWN ON THE STATION CROSS SECTIONS AND/OR AS DIRECTED BY THE ENGINEER.
MINIMUM 4% (1/2") DESIRABLE; MAXIMUM 8% (1")
7. WHEN MAILBOX TURNOUTS ARE CONSTRUCTED ADJACENT TO FIELD ENTRANCES, THE WIDTH OF THE INCIDENTAL HMA SURFACING CONSTRUCTED FOR THE FIELD ENTRANCE SHALL MATCH THE WIDTH OF THE PROPOSED MAILBOX TURNOUT SURFACING.
8. THE TOTAL SHOULDER WIDTH, 2.4 (8') MINIMUM, SHALL BE PAVED BETWEEN SIDEROADS ENTRANCES AND/OR MAILBOX TURNOUTS AT LOCATIONS WHERE THE DISTANCE BETWEEN RADIUS OR TAPER CONTROL POINTS IS LESS THAN 15.0 m (50').
9. MAILBOXES SHALL BE MOUNTED SUCH THAT THE FACE OF THE MAILBOX IS 6" (150 mm) TO 12" (300 mm) AND THE POST A MINIMUM OF 24" (600 mm) FROM THE EDGE OF THE TURNOUT SURFACING.

PROJECTS WITH RECONSTRUCTION

("3R" IMPROVEMENTS)

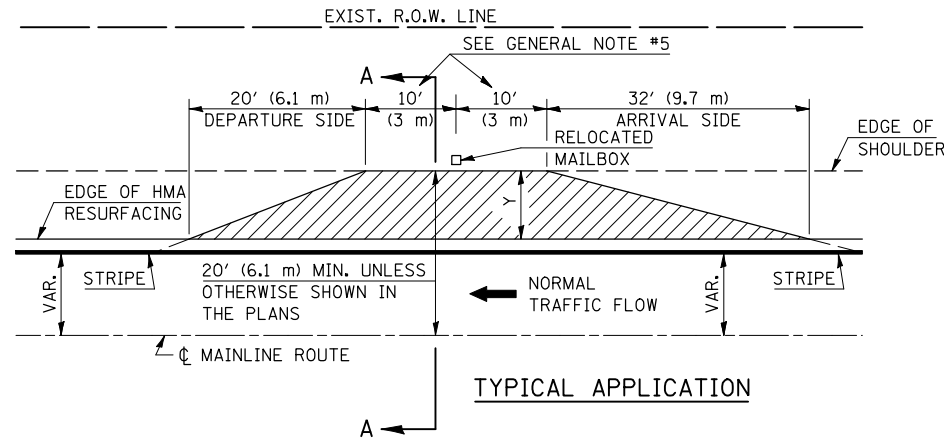

WIDTH OF SHOULDER	4'-0" - 8'-0" (1.2 m - 2.4 m)	10'-0" (3.0 m)
WIDTH OF TURNOUT "Y"	8'-0" (2.4 m)	8'-0" - 10'-0" (2.4 m - 3.0 m)

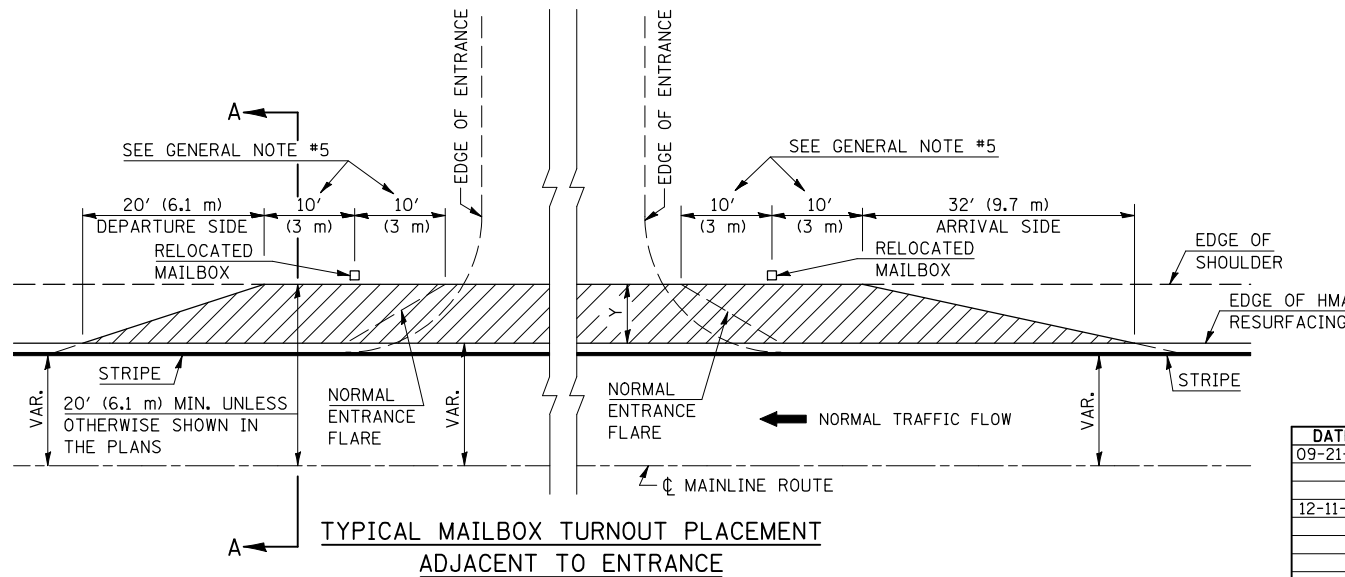
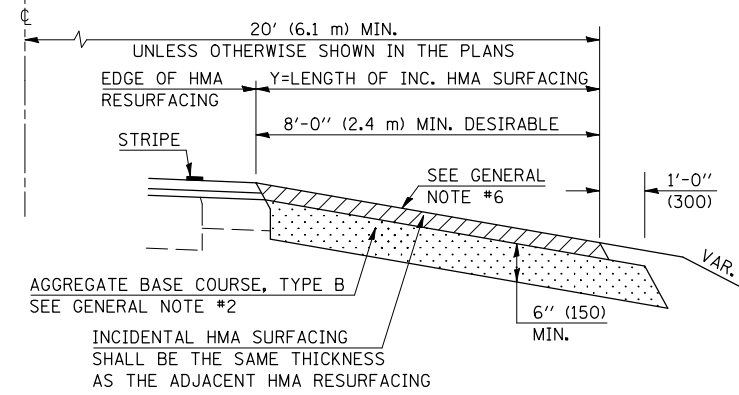

Note: All dimensions are in INCHES (millimeters) unless otherwise shown.

DATE	REVISIONS	NAME	ILLINOIS DEPARTMENT OF TRANSPORTATION
09-21-07	WIDTH CHANGE ARRIVAL SIDE AND VAR. CORRECTIONS	K.A.G.	MAILBOX TURNOUT (RURAL)
12-11-06	RENUMBERED/COMBINED C-1.25 WITH ADDITIONS OF S.M.A.R.T & 3P & 3R IMPROVEMENTS	T.J.B.	