

ROUTE NO.	SECTION	COUNTY	TOTAL SHEETS	SHEET NO.
F.A.P. 778	(2B-1)-1	SALINE	74	46
FED. ROAD DIST. NO. 9	ILLINOIS	FED. AID PROJECT-		

SHEET NO. 4  
8 SHEETS

STATE OF ILLINOIS  
DEPARTMENT OF TRANSPORTATION

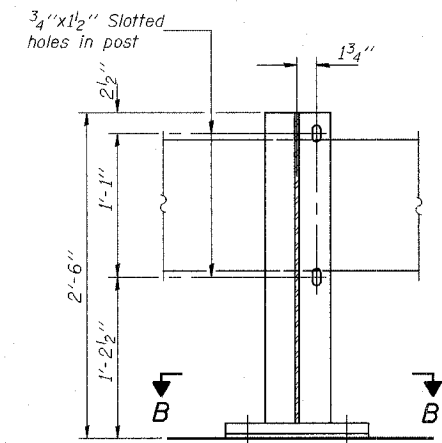

SECTION A-A

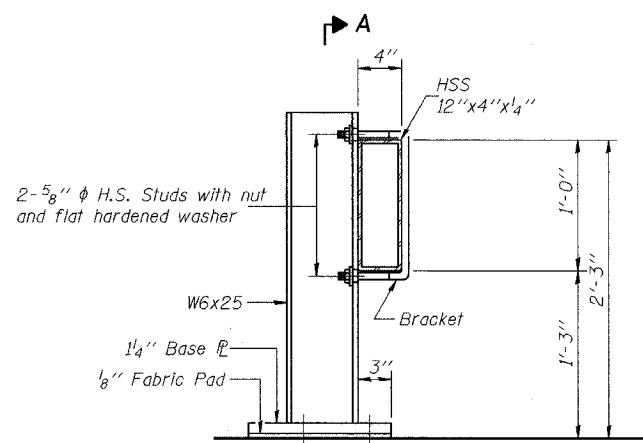

SECTION AT RAIL POST

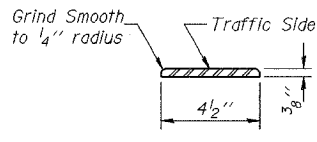

DETAIL A

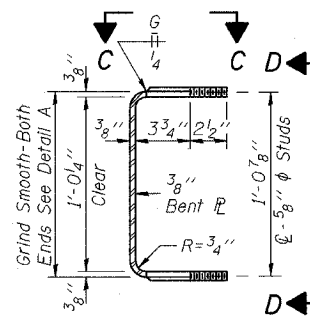

SECTION THRU BRACKET

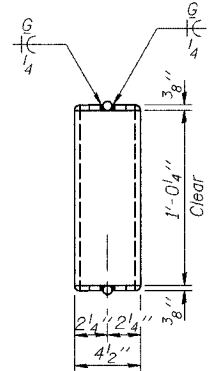

VIEW D-D

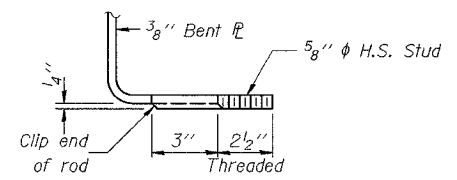

VIEW E-E

NOTES

Hollow structural sections shall conform to the requirements of ASTM designation A 500 Grade B Structural Steel Tubing.  
 All other steel shapes and plates shall conform to the requirements of AASHTO M 270 Grade 36 except posts and brackets shall conform to AASHTO M 270, Grade 50.  
 Bolts, cap screws, and nuts shall conform to the requirements of ASTM designation A 307 except for high strength bolts, threaded rods, studs, nuts and washers noted which shall conform to AASHTO M 164.  
 The bridge rail shall receive one shop coat of a steel prime paint.  
 The 1" high strength bolts or threaded rods used to connect the railposts shall be tightened according to Article 505.04(f)(2) of the Standard Specifications.  
 Temporary Bridge Rail shall be according to Section 514 of the Standard Specifications, except as noted, and will be paid for at the contract unit price per foot for Temporary Bridge Rail.  
 See sheet 2 of 8 for Rail Post spacing.  
 The contact surfaces between post flange, rail and inside face of bracket for Alternate I shall be free of all lubricants.  
 The nut for 5/8" high strength studs used in Alternate I to connect bracket to post shall be tightened to a snug fit and given an additional one half turn.

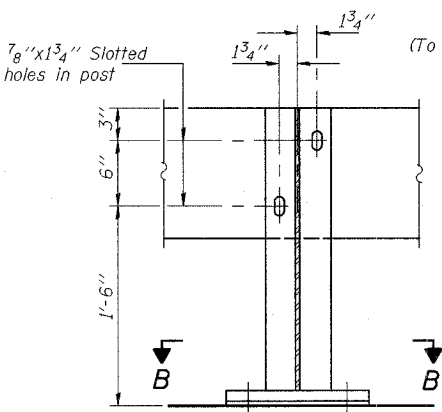

SECTION A-A

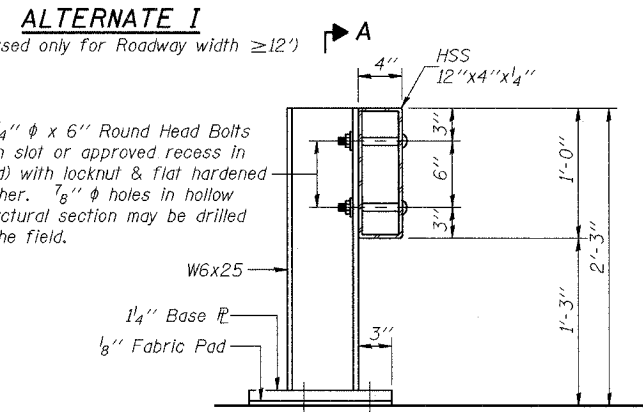

SECTION AT RAIL POST

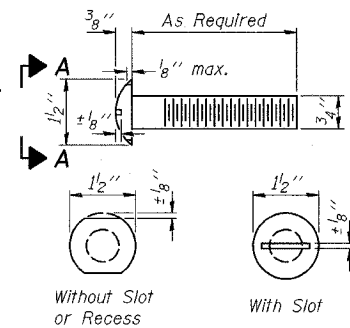

VIEW A-A  
ROUND HEAD BOLT

Wing type threaded inserts tapped for 1" H.S. bolts. (Insert Load Capacity = 14K min./bolt)

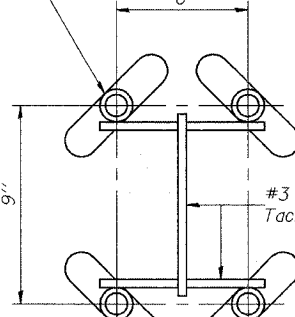

INSERT DETAIL

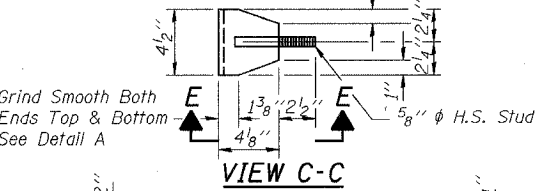

VIEW C-C

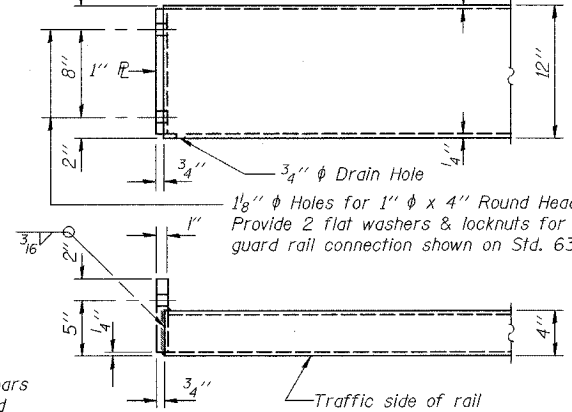

END OF RAIL DETAILS

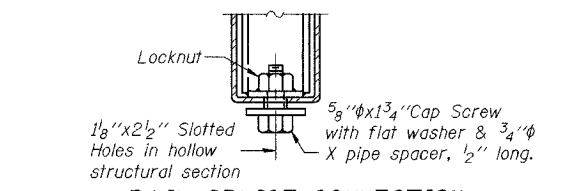

RAIL SPLICE CONNECTION  
AT EXPANSION JT.

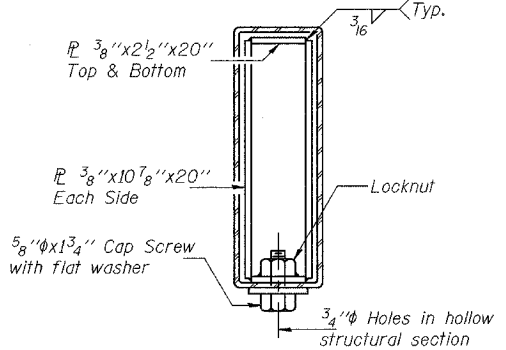

SECTION AT RAIL SPLICE

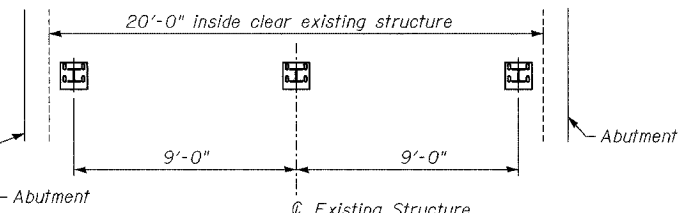

TEMPORARY BRIDGE RAIL POST SPACING

BILL OF MATERIAL

Item	Unit	Quantity
Temporary Bridge Rail	Foot	23

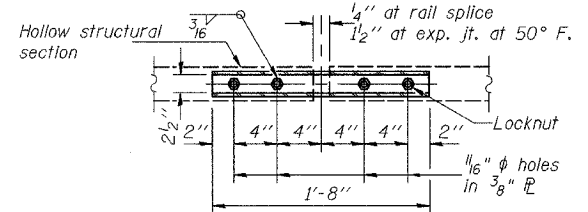

PLAN-BOTT. SPLICE P  
TYPICAL

**TEMPORARY BRIDGE RAIL**  
 IL. ROUTE 34 OVER UNNAMED TRIBUTARY  
 TO SOUTH FORK SALINE RIVER  
 FAP ROUTE 778 - SEC. (2B-1)-1  
 SALINE COUNTY  
 STATION 441+40.60  
 STRUCTURE NO. 083-2016

ALTERNATE I  
(To be used only for Roadway width ≥ 12')

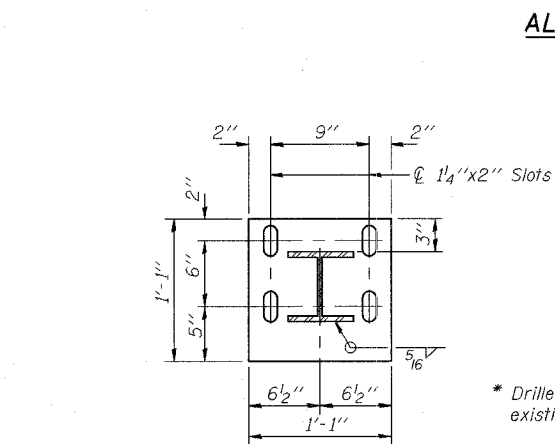

SECTION B-B

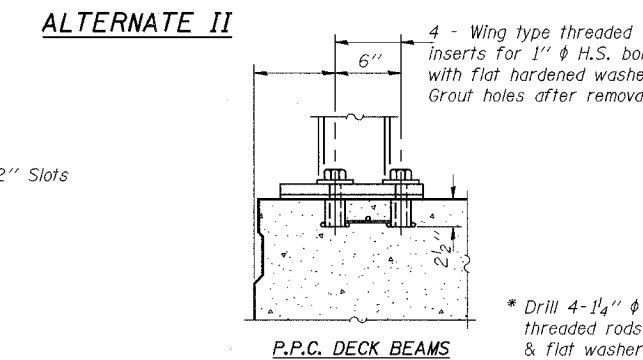

P.R.C. DECK BEAMS

\* Drilled holes for existing deck.

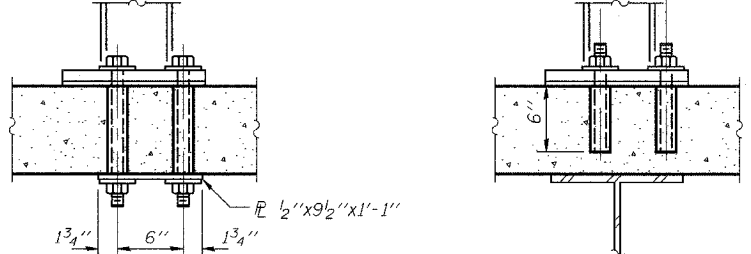

NEW & EXISTING DECKS  
ANCHORAGE DETAILS

DESIGNED	SBM
CHECKED	KMN
DRAWN	MSJ
CHECKED	WCC

R-25 10-31-02 (10'-9" Maximum Post Spacing)