



CITY OF DIXON, ILLINOIS

Post Office Box 386
Dixon, Illinois 61021
Telephone: 815.288.1485

DIXON MUNICIPAL AIRPORT
CHARLES R. WALGREEN FIELD
OVERLAY RUNWAY 8-26,
REHABILITATE HANGAR PAVEMENTS

AIP PROJECT NO. 3-17-0036-B5
IDA PROJECT NO. C73-3313

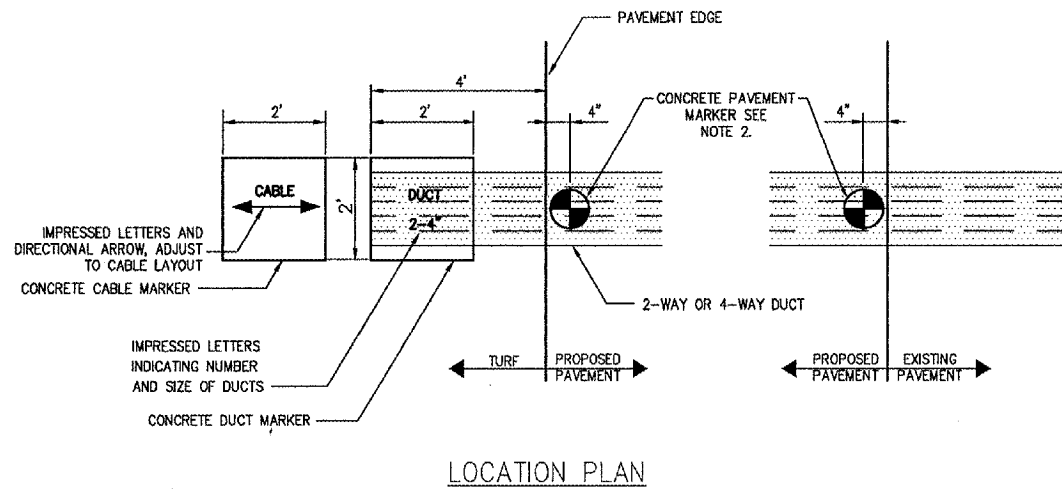

LOCATION PLAN

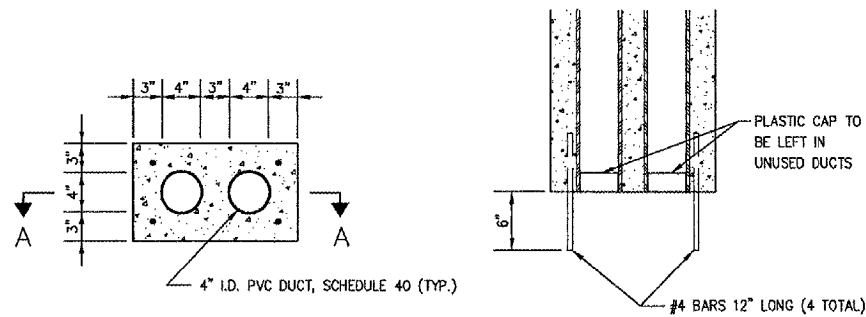

2-WAY
SECTION A-A
CONCRETE ENCASED DUCT CONFIGURATION

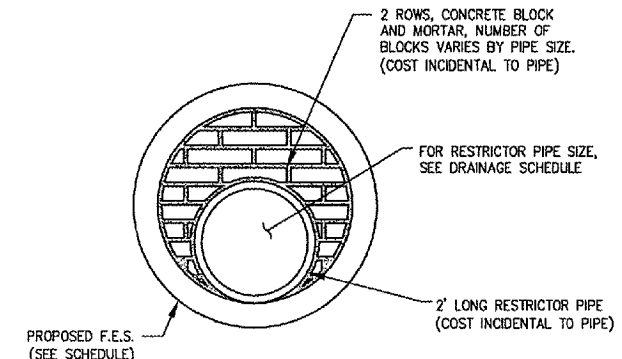

RESTRICTOR PIPE

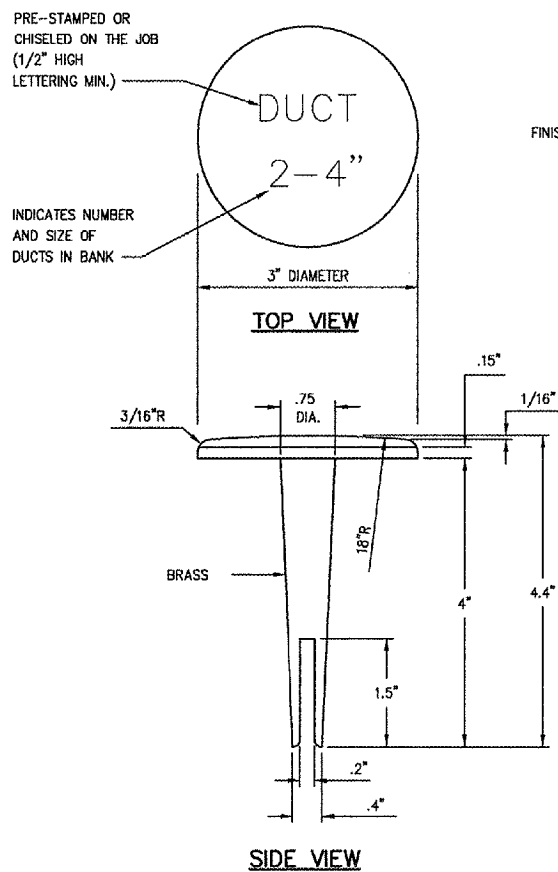

BITUMINOUS PAVEMENT MARKER

TURF AND PAVEMENT DUCT AND CABLE MARKERS

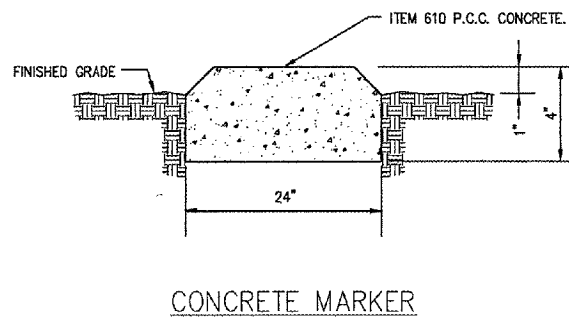

NOTES

1. THE COSTS OF ALL TURF AND PAVEMENT DUCT MARKERS SHALL BE INCIDENTAL TO THE DUCT. THE COST OF ALL CABLE MARKERS SHALL BE INCIDENTAL TO THE CABLE.
2. BITUMINOUS PAVEMENT DUCT MARKER AND CONCRETE DUCT MARKER TO BE PROVIDED AT EACH END OF EACH DUCT AS SHOWN ON THE LOCATION PLAN. FOR CONCRETE PAVEMENT, THE LETTER "D" SHALL BE IMPRESSED IN THE PAVEMENT INSTEAD OF THE MARKER. THE LETTER SHALL BE FORMED AS DESCRIBED IN NOTE 4.
3. CABLE MARKERS SHALL BE PLACED AT CHANGES OF DIRECTION AND EVERY 200' ALONG CABLE RUNS.
4. LETTERS 4" HIGH, 3" WIDE WITH WIDTH OF STROKE 1/2" AND 1/4" DEEP. ALL LETTERS, NUMBERS AND ARROWS TO BE IMPRESSED.

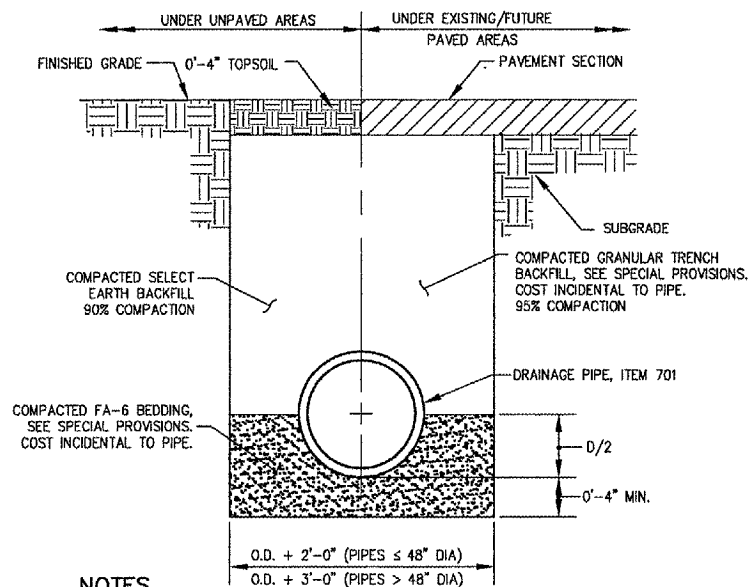

NOTES

1. UNSUITABLE MATERIAL ENCOUNTERED DURING PLACEMENT OF BEDDING SHALL BE REMOVED AND REPLACED.
2. WITHIN 3 FEET OF EXISTING AND FUTURE PAVED AREA, GRANULAR BACKFILL IS TO BE USED INSTEAD OF EARTH BACKFILL.

PIPE TRENCH

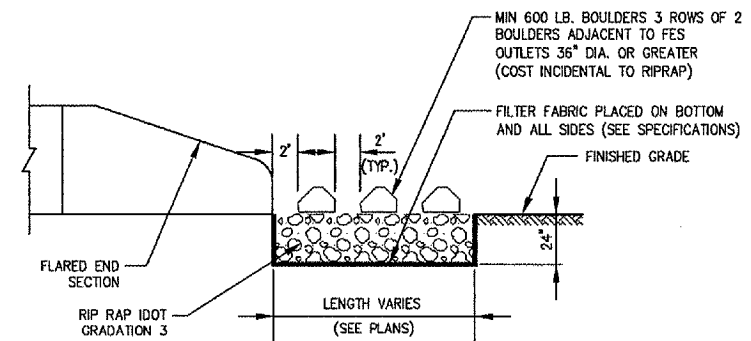

SECTION B-B

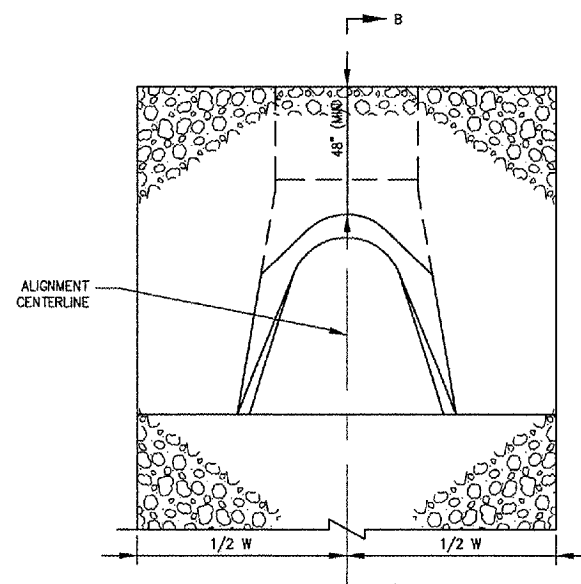

NOTE

1. COST OF FILTER FABRIC IS INCIDENTAL TO RIPRAP.
2. WIDTH (W) OF RIPRAP VARIES, SEE PLAN.

RIPRAP

DETAILS SHOWN ARE NOT TO SCALE

No.	Drawing Issue Description	Date	By

Date
12 MARCH 2004
Sheet Title

UTILITY DETAILS

8430388004/C8005
Project Number
KLK 01/05/04
Layout By Date
TMM 01/09/04
Designed By Date
RMH 03/05/04
Reviewed By Date
KLK
Drawn By Sheet No.

10-3-005 10043 0388004 DRAWINGS SHEETS 60- TRENCH & DUCTBANK DETAILS.DWG MAR 12, 2004 8:48AM RJT