

**PLAN**

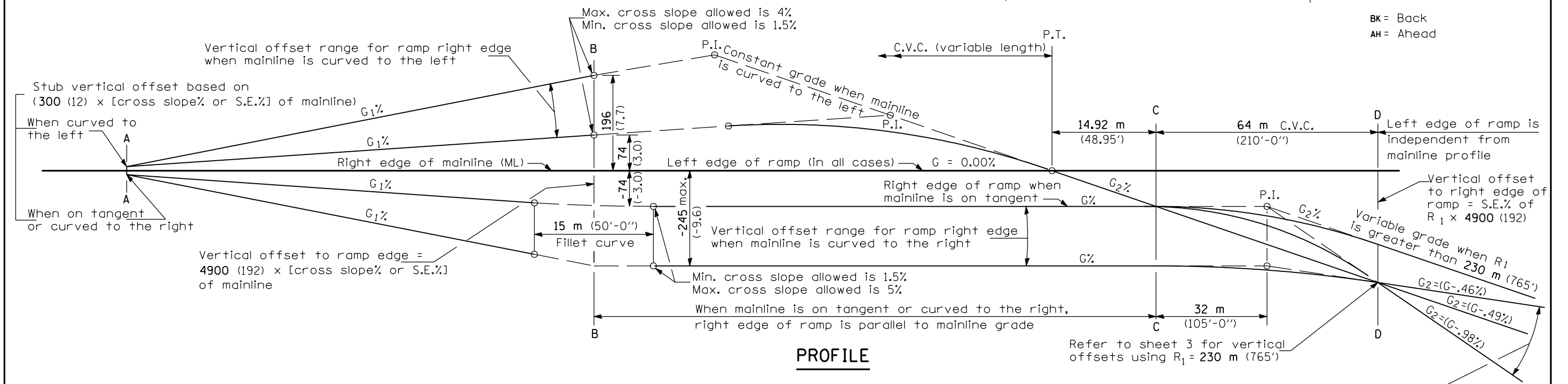

**PROFILE**

Illinois Department of Transportation  
 PASSED January 1, 2004  
 Michael Brand  
 ENGINEER OF POLICY AND PROCEDURES  
 APPROVED January 1, 2004  
 Michael L. Hine  
 ENGINEER OF DESIGN AND ENVIRONMENT  
 ISSUED 1-1-97

DATE	REVISIONS
1-1-04	Minor corrections of joint information.
1-1-03	Corrected stub location, title and minor errors.

**EXIT RAMP TERMINAL**  
 (JOINTED PCC RAMP PAVEMENT  
 ADJACENT TO JOINTED PCC MAINLINE PAVEMENT)  
 (Sheet 1 of 3)  
**STANDARD 420301-03**

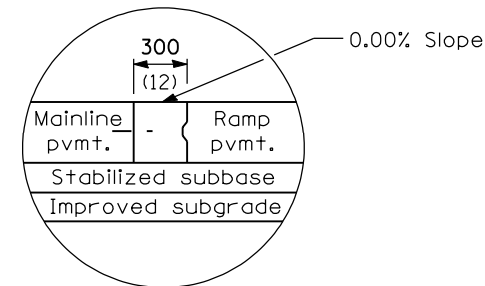
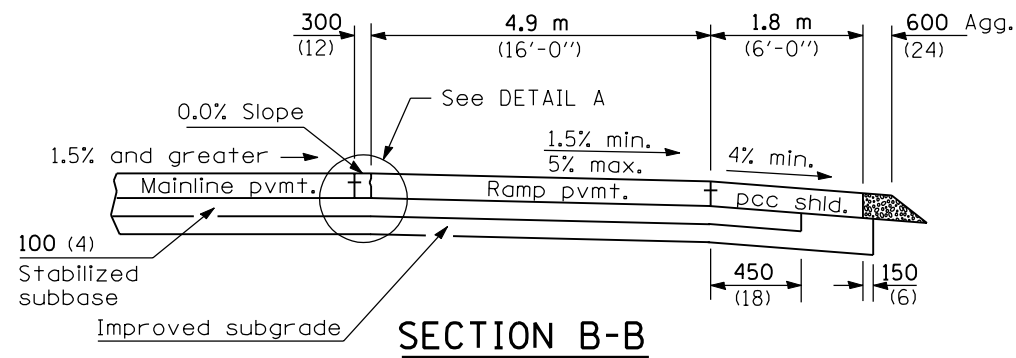

**DETAIL A**

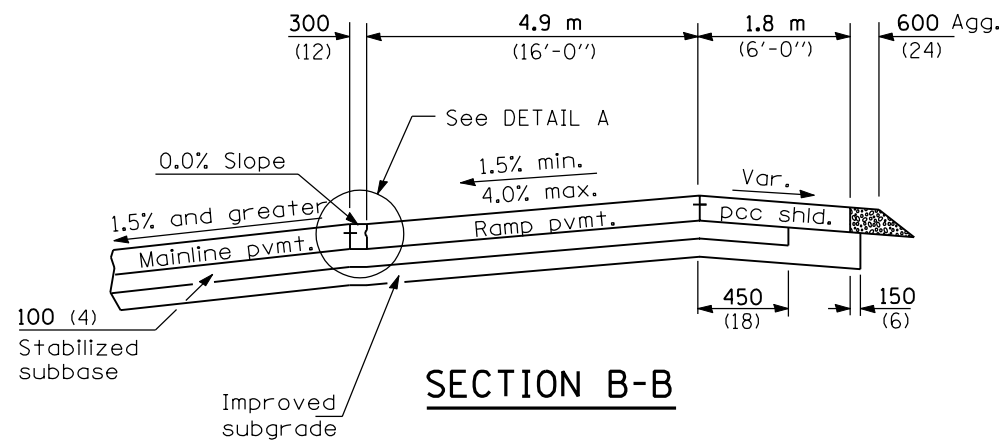

**SECTION B-B**

**WHEN MAINLINE IS ON TANGENT OR CURVED TO THE RIGHT**

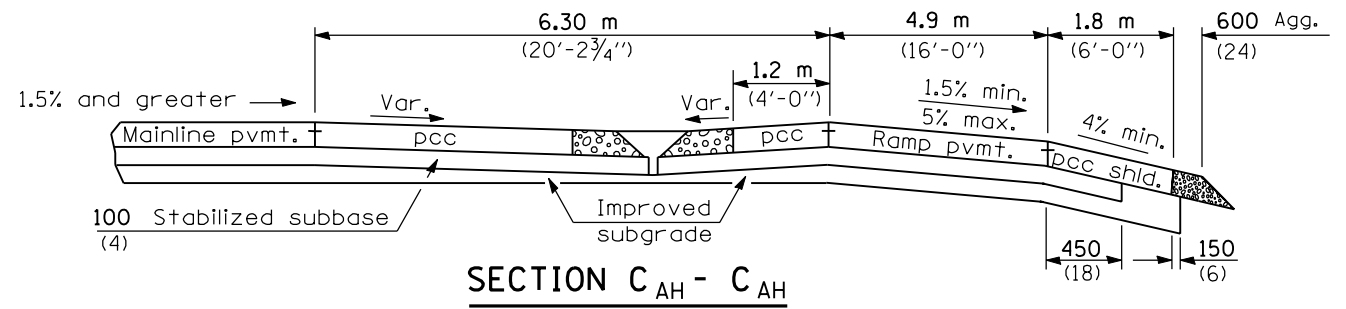

**SECTION C<sub>AH</sub> - C<sub>AH</sub>**

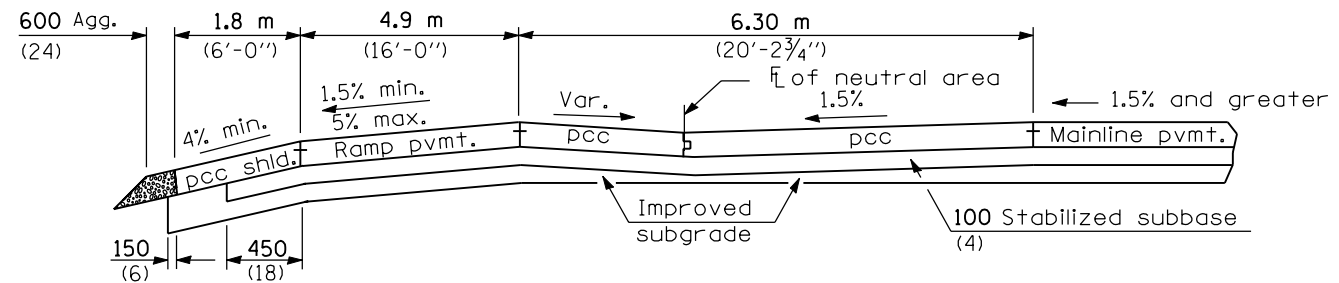

**SECTION C<sub>BK</sub> - C<sub>BK</sub>**

BK = Back  
AH = Ahead

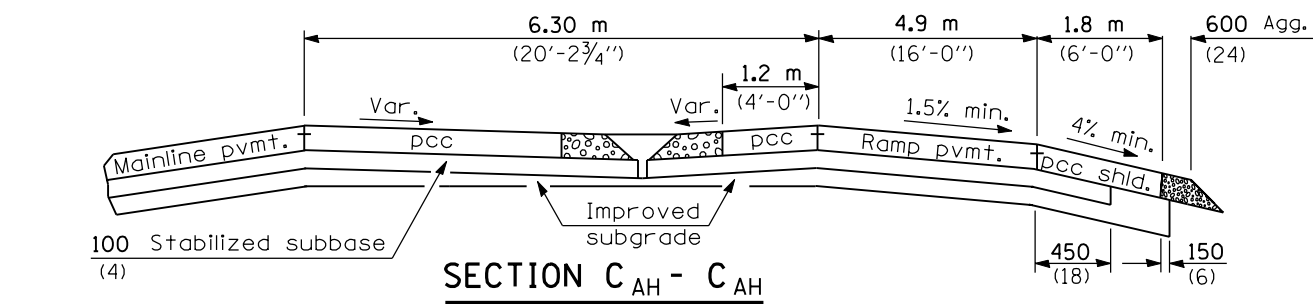

**SECTION C<sub>AH</sub> - C<sub>AH</sub>**

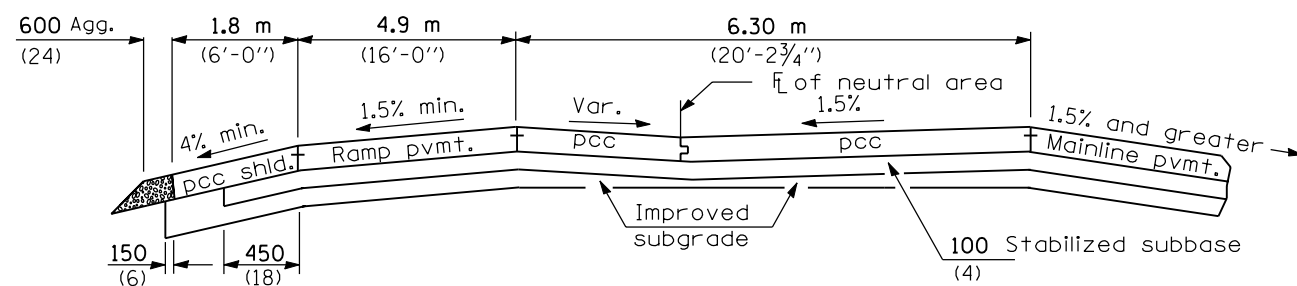

**SECTION C<sub>BK</sub> - C<sub>BK</sub>**

See Sheet 3 for GENERAL NOTES

**WHEN MAINLINE IS CURVED TO THE LEFT**

Illinois Department of Transportation

PASSED January 1, 2004  
*Michael Brand*  
 ENGINEER OF POLICY AND PROCEDURES

APPROVED January 1, 2004  
*Michael L. Hine*  
 ENGINEER OF DESIGN AND ENVIRONMENT

ISSUED 1-1-97

**EXIT RAMP TERMINAL**

(JOINTED PCC RAMP PAVEMENT  
 ADJACENT TO JOINTED PCC MAINLINE PAVEMENT)  
 (Sheet 2 of 3)

**STANDARD 420301-03**

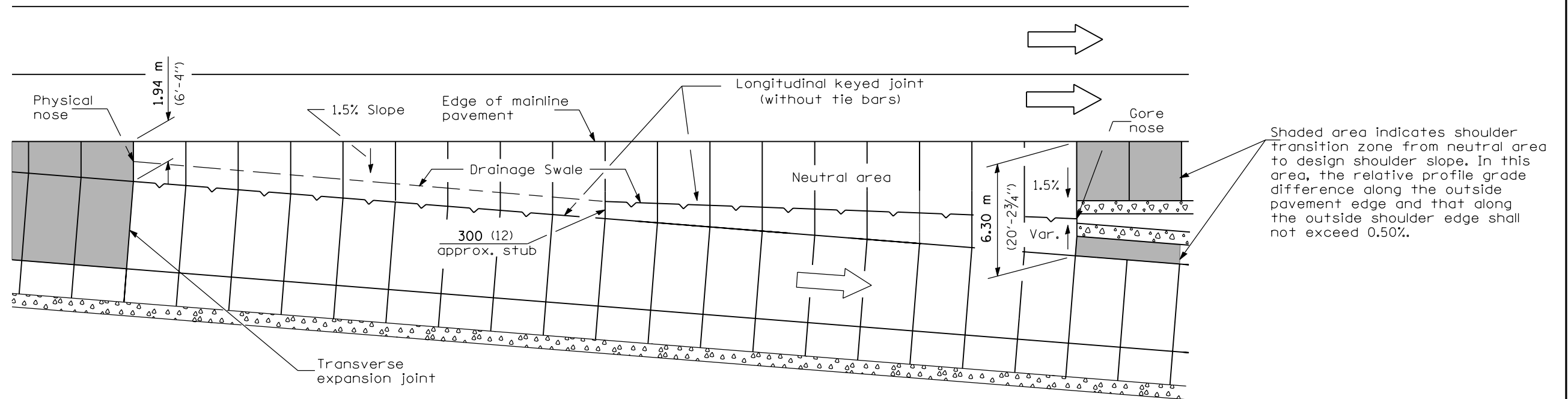

**DETAILS FOR DRAINAGE IN NEUTRAL AREA**

**GENERAL NOTES**

The initial ramp grade (G<sub>2</sub>) is based on the line generated through the PI that is 32 m past Section C-C and the point created by the vertical offset at Section D-D.

See plans for actual grades.

All pavement joints shall be detailed as shown on Standards 420001 and 483001.

See Standard 483001 for ramp shoulder details.

In the neutral area, provide a swale and flush inlet to enhance drainage.

When using grades expressed in %, the grade values shall be divided by 100 to obtain vertical offsets.

Where an exit ramp terminal is proposed adjacent to a mainline horizontal curve, construct the edge of the terminal by using offset widths, and for the terminal segment downstream from Section C-C to R<sub>1</sub>, construct the ramp as a 43 m tangent section.

All dimensions are in millimeters (inches) unless otherwise shown.

① Vertical offsets in mm for right edge of ramp, when R<sub>1</sub> = 230 m

Sections	Mainline on Tangent	Mainline Curved Right	Mainline Curved Left
A	- 5	S.E.% ML x 300	S.E.% ML x 300 ②
B	- 74	S.E.% ML x 4900	S.E.% ML x 4900 ②
C	- 74	S.E.% ML x 4900	- 74
D	- 392	- 392	- 392

Vertical offsets in inches for right edge of ramp, when R<sub>1</sub> = 765'

Sections	Mainline on Tangent	Mainline Curved Right	Mainline Curved Left
A	- 0.18	S.E.% ML x 12	S.E.% ML x 12 ②
B	- 3.0	S.E.% ML x 192	S.E.% ML x 192 ②
C	- 3.0	S.E.% ML x 192	- 3.0
D	- 15.4	- 15.4	- 15.4

① Vertical offset values are calculated and based on the right edge of mainline pavement at 0.0 % grade.

② The vertical offsets of these points are above the mainline pavement and lie on an upgrade in relationship to the mainline grade.

③ S.E.=Superelevation Rate

Illinois Department of Transportation

PASSED January 1, 2004  
*Michael Brand*  
 ENGINEER OF POLICY AND PROCEDURES

APPROVED January 1, 2004  
*Michael L. Hine*  
 ENGINEER OF DESIGN AND ENVIRONMENT

ISSUED 1-1-97

**EXIT RAMP TERMINAL**  
 (JOINTED PCC RAMP PAVEMENT  
 ADJACENT TO JOINTED PCC MAINLINE PAVEMENT)  
 (Sheet 3 of 3)

**STANDARD 420301-03**