

FAU RTE.	SECTION	COUNTY	TOTAL SHEETS	SHEET NO.
2802/1537	09-00032-00-RS	COOK	18	4
STA. 10+00		TO STA. 37+87.89		
FED. ROAD DIST. NO.	ILLINOIS	FED. AID PROJECT		
CONTRACT NO. 63410				

STRUCTURAL DESIGN INFORMATION

STRUCTURAL DESIGN TRAFFIC: YEAR 2020

PV= 7400 SU= 900 MU= 1700

ROAD/STREET CLASSIFICATION: CLASS II

PERCENT OF STRUCTURAL DESIGN TRAFFIC IN DESIGN LANE:

P= 50 S= 50 M= 50

TRAFFIC FACTOR: ACTUAL T.F.= 5.20
MINIMUM T.F.= N/A

PG GRADE: BINDER= 64-22 SURFACE= 64-22

IBR= 2.5 SSR= FAIR

hbe **Hoeffler-Butler Engineering, Inc.**
Consulting Civil Engineers • Land Surveyors
PROFESSIONAL DESIGN FIRM LICENSE NO. 164-00885
8714 S. ROBERTS ROAD • ROCKFORD, ILLINOIS 61107-6857
C/O 579-6580 FAX C/O 579-5726

- | | |
|--|--|
| ① EX. P.C.C. PAVEMENT, 10 3/4" | ⑦ POLYMERIZED LEVELING BINDER (MACHINE METHOD), IL-4.75, N50, 3/4"-1" (IF NECESSARY) |
| ② EX. COMBINATION CURB & GUTTER, TY B6.12 | ⑧ POLYMERIZED HMA SURFACE COURSE, MIX 'F', N90, 1 3/4" |
| ③ EX. SUB-BASE GRANULAR MATERIAL, 4" | ⑨ CURB & GUTTER REMOVAL AND REPLACEMENT (WHERE MARKED IN FIELD) |
| ④ EXISTING P.C.C. SIDEWALK, 5" | ⑩ PROPOSED P.C.C. SIDEWALK, 5" |
| ⑤ P.C.C. SURFACE REMOVAL (COLD MILLING) VARIABLE DEPTH | |
| ⑥ CLASS 'B' PATCHES, 11" | |

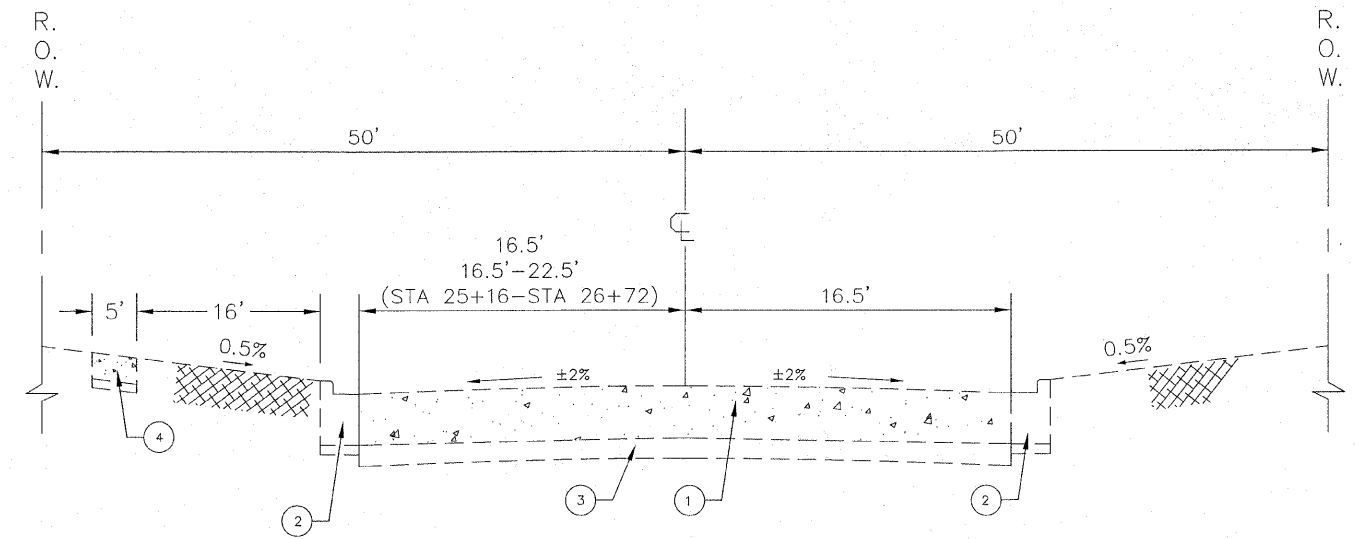

EXISTING TYPICAL SECTION
STA 25+16 TO STA 37+57.89, SAYRE AVENUE

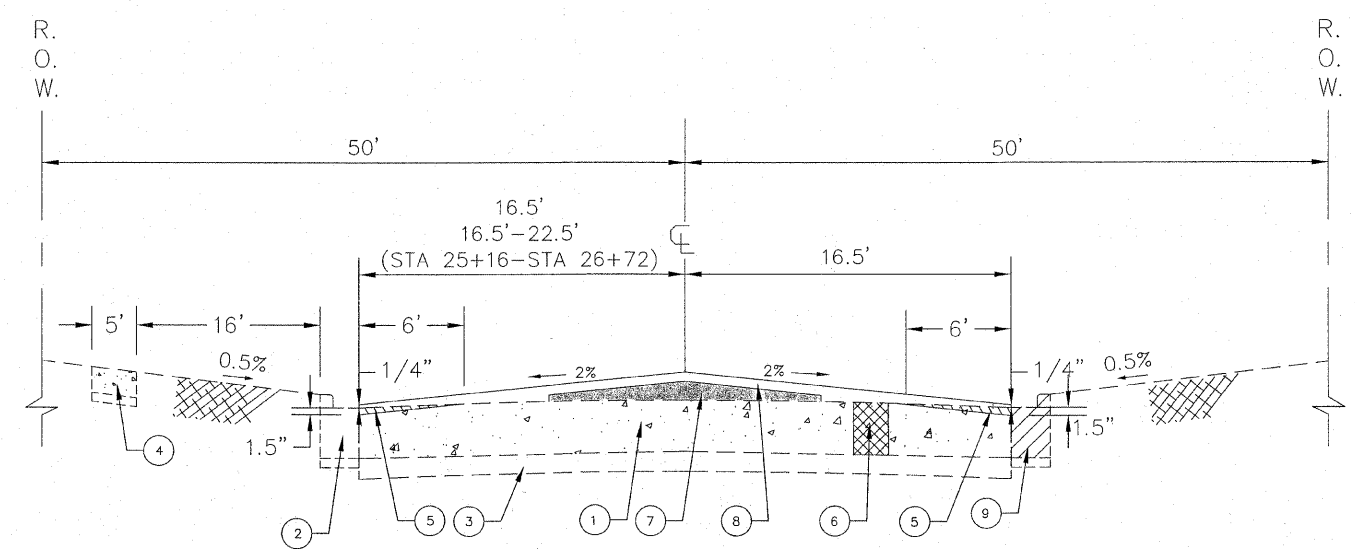

PROPOSED TYPICAL SECTION
STA 25+16 TO STA 37+57.89, SAYRE AVENUE

NOTE: CROSS-HATCHED ITEMS ARE TO BE REMOVED

REVISIONS	NAME	DATE
1	JMH PER REVIEW	01/06/10
2	JMH PER REVIEW	01/19/10
3	JMH PER REVIEW	01/21/10

ILLINOIS DEPARTMENT OF TRANSPORTATION
VILLAGE OF BEDFORD PARK
71st ST & SAYRE AVE RESURFACING
71st ST @ HARLEM TO SAYRE @ 73rd ST
SCALE: TYPICAL CROSS SECTIONS
N.T.S.
DRAWN BY: JMH
CHECKED BY: SAL
DATE: 10/09/09