

Bridge Approach Resurfacing

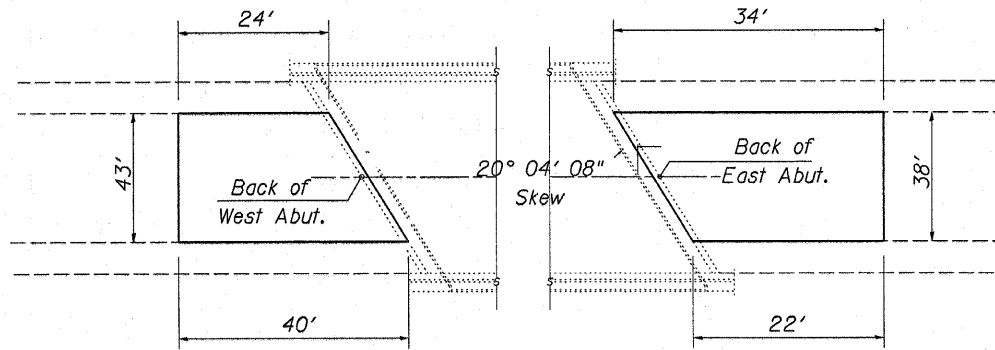

Structure No. 101-0071
Eastbound Structure

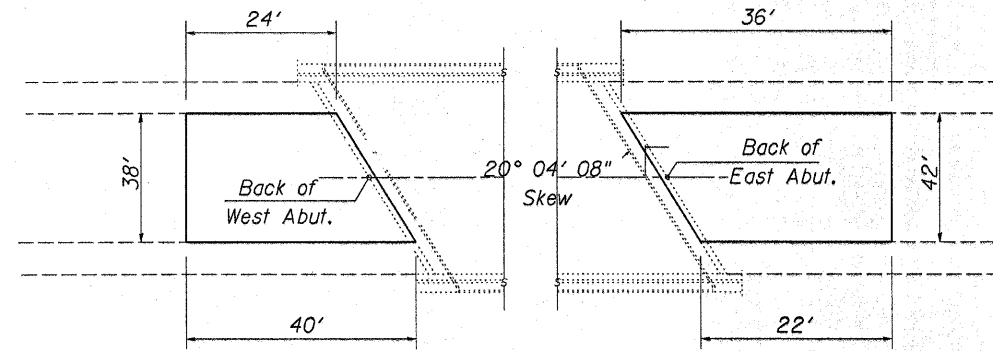

Structure No. 101-0072
Westbound Structure

Striping quantities include restriping pavement 150' each side of each bridge plus bridges with 2 coats of paint

Paint Pavement Marking - Line 6"

HOT-MIX ASPHALT SURFACE REMOVAL 1/2"

	Square Yard
101-0067	
East Approach	76
West Approach	131
101-0068	
East Approach	71
West Approach	76
101-0069	
East Approach	134
West Approach	200
101-0070	
East Approach	208
West Approach	168
101-0071	
East Approach	119
West Approach	153
101-0072	
East Approach	136
West Approach	136
Total	1608

POLYMERIZED HOT-MIX ASPHALT SURFACE COURSE, MIX "E", N90

	Ton
101-0067	
East Approach	7
West Approach	11
101-0068	
East Approach	6
West Approach	7
101-0069	
East Approach	12
West Approach	17
101-0070	
East Approach	18
West Approach	15
101-0071	
East Approach	10
West Approach	13
101-0072	
East Approach	12
West Approach	12
Total	140

	Foot		
	Right Edge	Centerline	Left Edge
101-0067	170	43	170
East Approach	150	38	150
West Approach	150	38	150
101-0068	170	43	170
East Approach	150	38	150
West Approach	150	38	150
101-0069	280	70	280
East Approach	150	38	150
West Approach	150	38	150
101-0070	280	70	280
East Approach	150	38	150
West Approach	150	38	150
101-0071	230	58	230
East Approach	150	38	150
West Approach	150	38	150
101-0072	230	58	230
East Approach	150	38	150
West Approach	150	38	150
Total	3160	798	3160

3160
798
3160
7118 Feet x 2 coats = 14,236 Feet Total Quantity