

F.A.I. RTE.	SECTION	COUNTY	TOTAL SHEETS	SHEET NO.
80	(50-3)HBK	LASALLE	492	290D
CONTRACT NO. 66542				

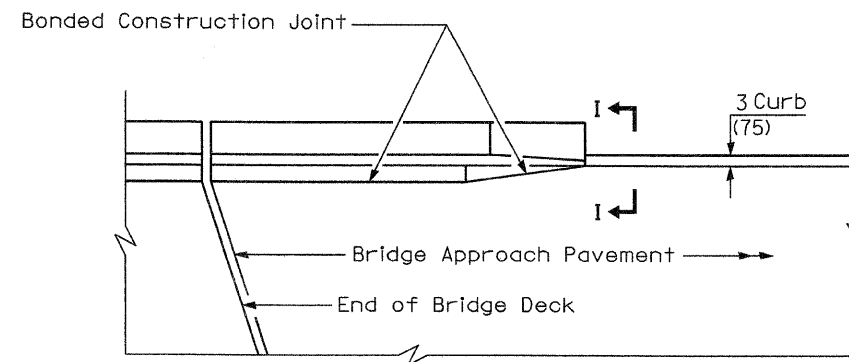

**PARAPET TO CURB TRANSITION
PILE BENT ABUTMENT**

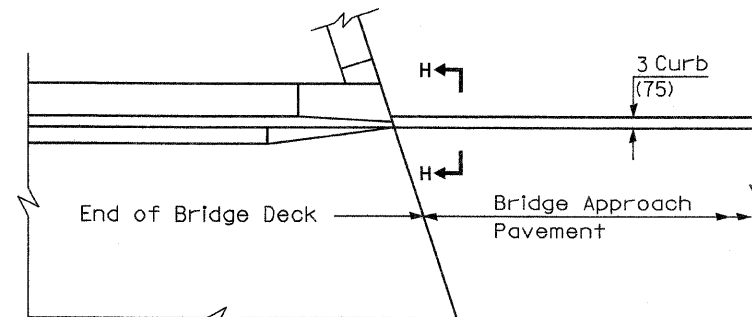

**PARAPET TO CURB TRANSITION
INTEGRAL ABUTMENT**

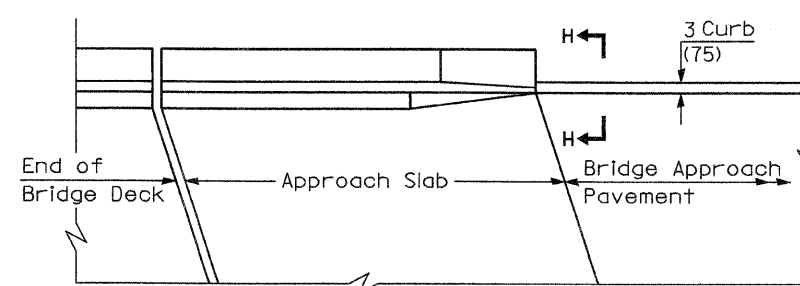

**PARAPET TO CURB TRANSITION
VAULTED ABUTMENT**

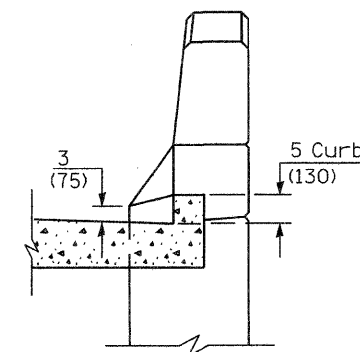

SECTION I - I

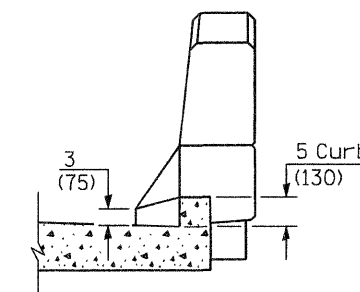

SECTION H - H

BRIDGE APPROACH PAVEMENT

(Sheet 4 of 4)

Illinois Department of Transportation

APPROVED January 1, 2008
Palak E. Arshwan
 ENGINEER OF BRIDGES AND STRUCTURES

APPROVED January 1, 2008
Eric E. Han
 ENGINEER OF DESIGN AND ENVIRONMENT

JRP-1-1 GEN/SST