

**TYPE A**

6'-3" (1.905 m) Typical post spacing

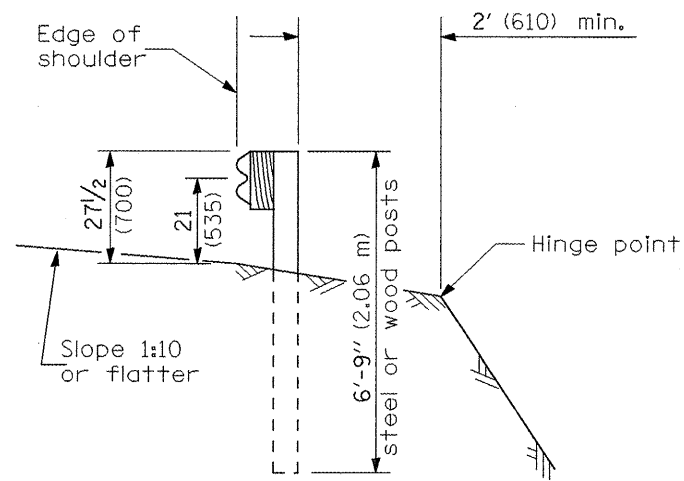

**SECTION A-A**

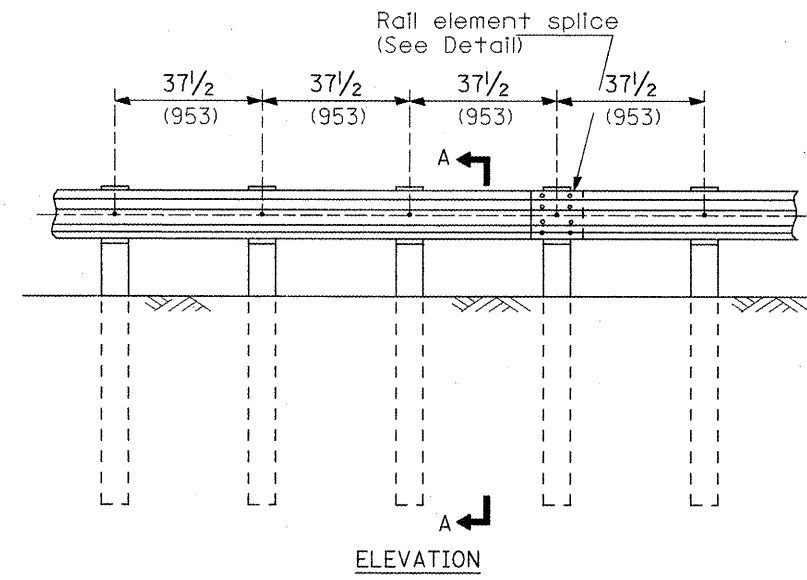

**TYPE B**

37 1/2 (953) Closed post spacing

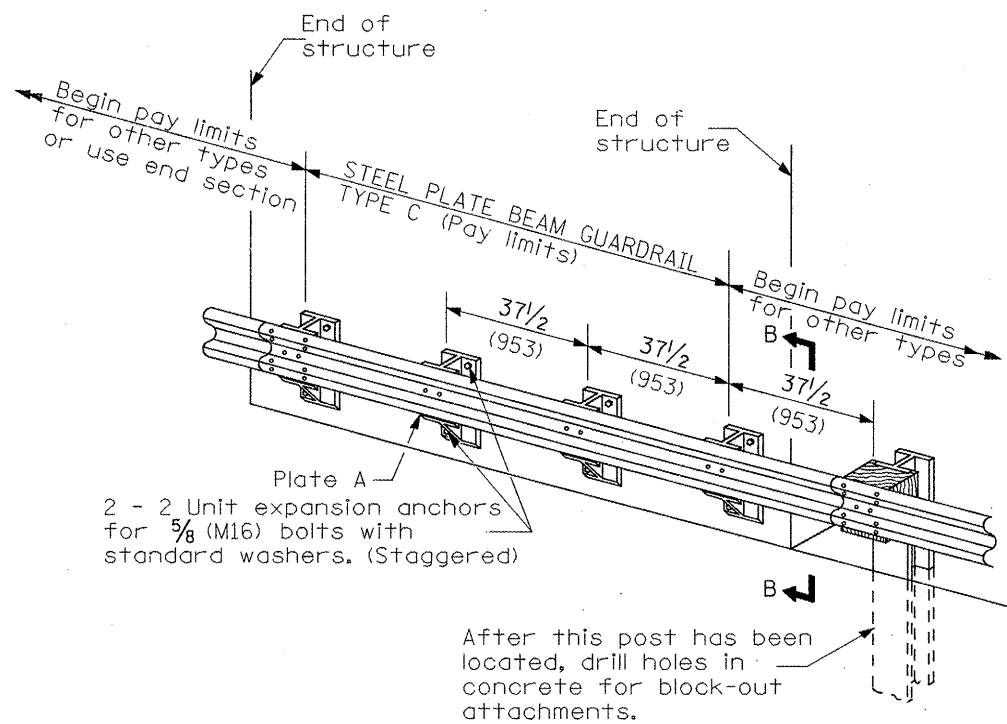

**TYPE C**

37 1/2 (953) Block-out spacing

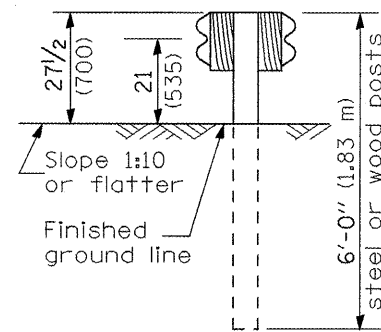

**SECTION C-C**

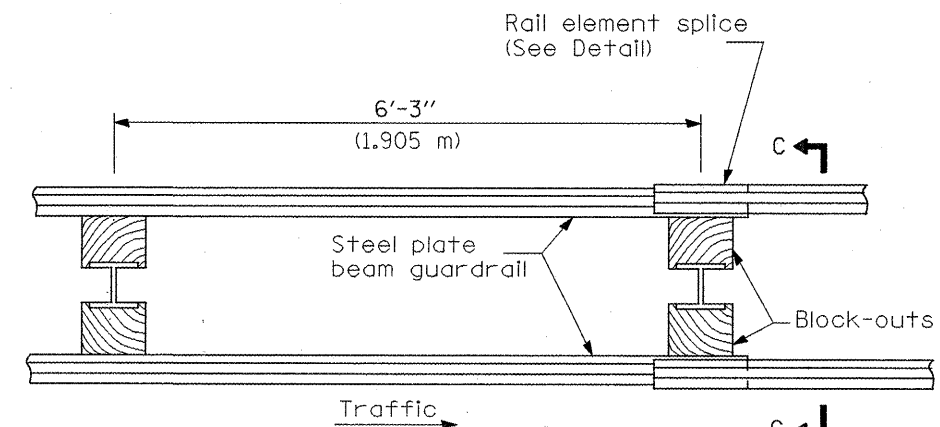

**PLAN**

**TYPE D**

Double steel plate beam guardrail  
6'-3" (1.905 m) typical post spacing

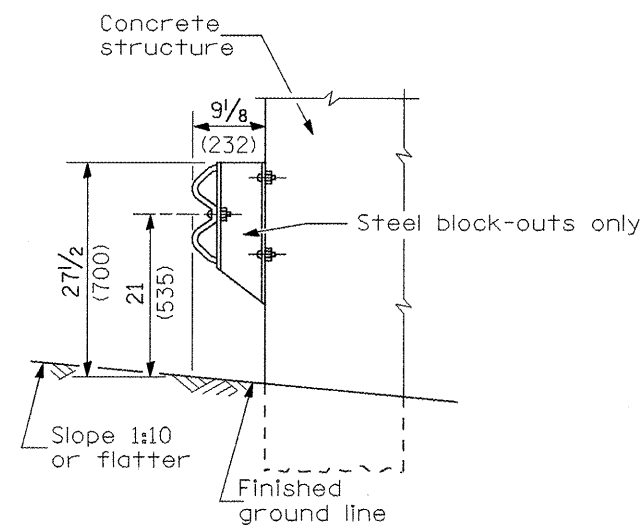

**SECTION B-B**

**GENERAL NOTES**

All slope ratios are expressed as units of vertical displacement to units of horizontal displacement (V:H).

All dimensions are in millimeters (inches) unless otherwise shown.

The existing steel posts may be drilled to match the bolt pattern shown herein for the wood block-out, or a new steel post shall be provided.

This detail is applicable to the guardrail system used prior to January 1, 2007. For details on the Midwest Guardrail System, see Standard 630001.

All dimensions are in inches (millimeters) unless otherwise noted.

03-01-07	NEW DETAIL	RJD			
----------	------------	-----	--	--	--

**STATE OF ILLINOIS  
DEPARTMENT OF TRANSPORTATION**

**REMOVE AND REERECT STEEL PLATE BEAM GUARDRAIL**

NOT TO SCALE

SHT. 1 OF 4  
CADD STD. 630011-D4

F.A.P. RTE.	SECTION	COUNTY	TOTAL SHEETS	SHEET NO.
673	**	TAZE/WOOD	60	52
FED. ROAD DIST. NO.			CONTRACT NO. 68920	
ILLINOIS			FED. AID PROJECT	