

STEEL POST CONSTRUCTION

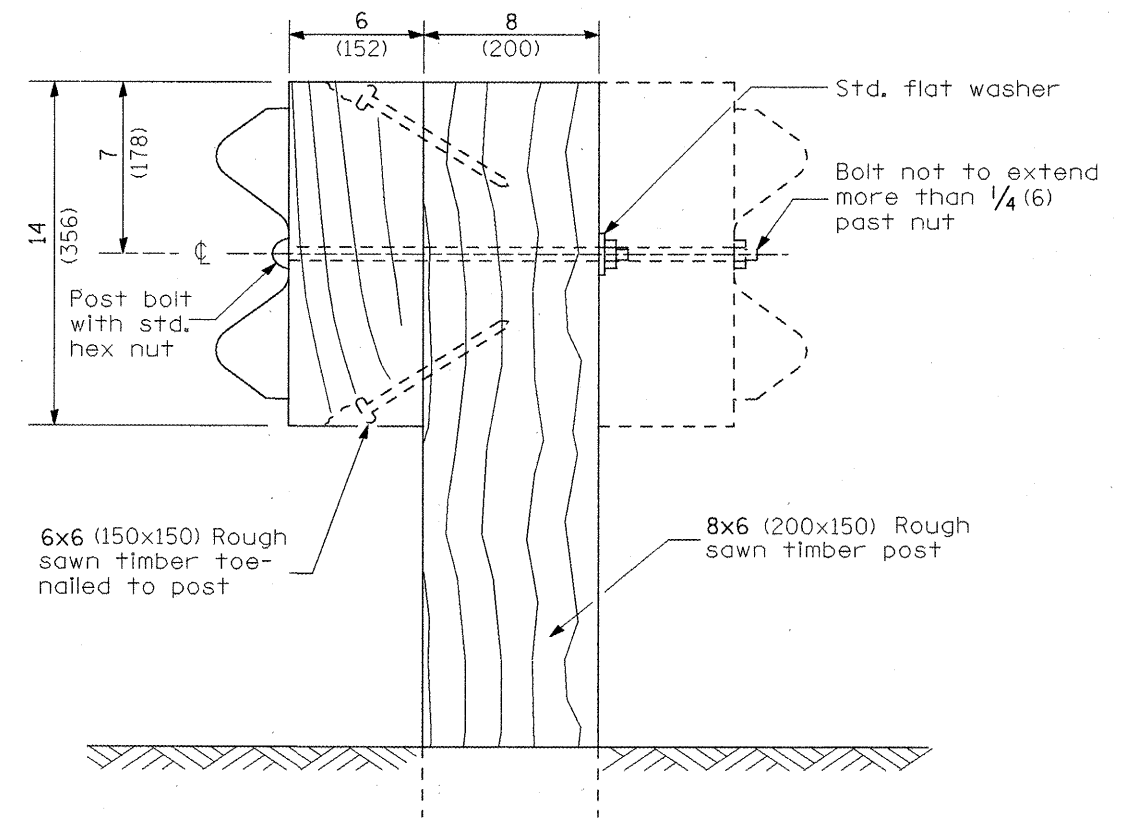

WOOD POST CONSTRUCTION

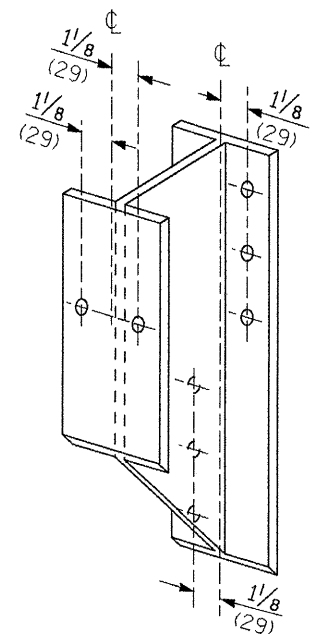

STEEL BLOCK-OUT DETAIL

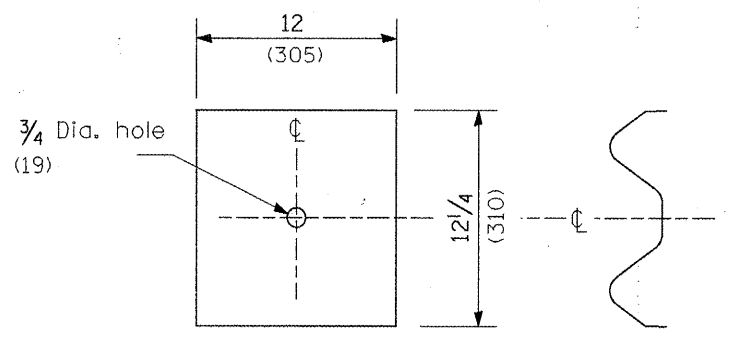
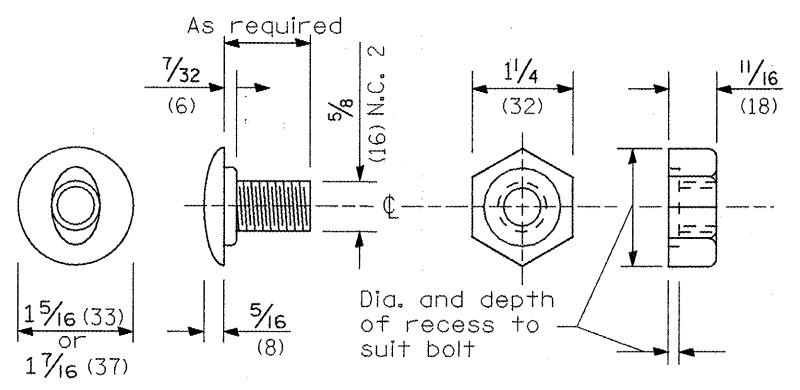

PLATE A

NOTE
Plate A shall be placed between rail element and block-out at non-splice mounting points only when steel block-outs are used.



POST OR SPLICE BOLT & NUT

All dimensions are in inches (millimeters) unless otherwise noted.

**STATE OF ILLINOIS
DEPARTMENT OF TRANSPORTATION**

REMOVE AND REERECT STEEL PLATE BEAM GUARDRAIL
SHT. 2 OF 4
CADD STD. 630011-D4
NOT TO SCALE

F.A.P. RTE.	SECTION	COUNTY	TOTAL SHEETS	SHEET NO.
673	..	TAZE/WOOD	60	53
FED. ROAD DIST. NO. [ILLINOIS] FED. AID PROJECT			CONTRACT NO. 68920	