

TYPICAL MOUNTING DETAIL FOR BRIDGE RAIL REFLECTOR

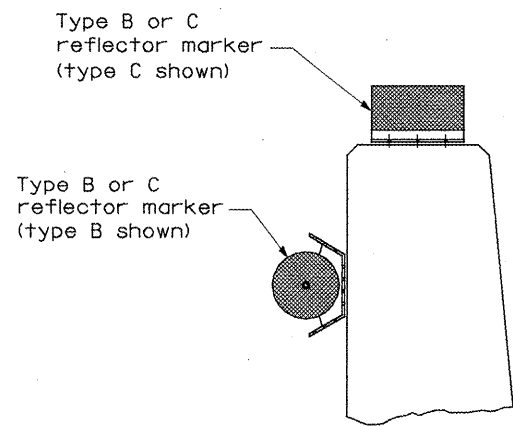

TYPICAL MOUNTING DETAIL FOR BARRIER WALL REFLECTOR

REFLECTOR MOUNTING

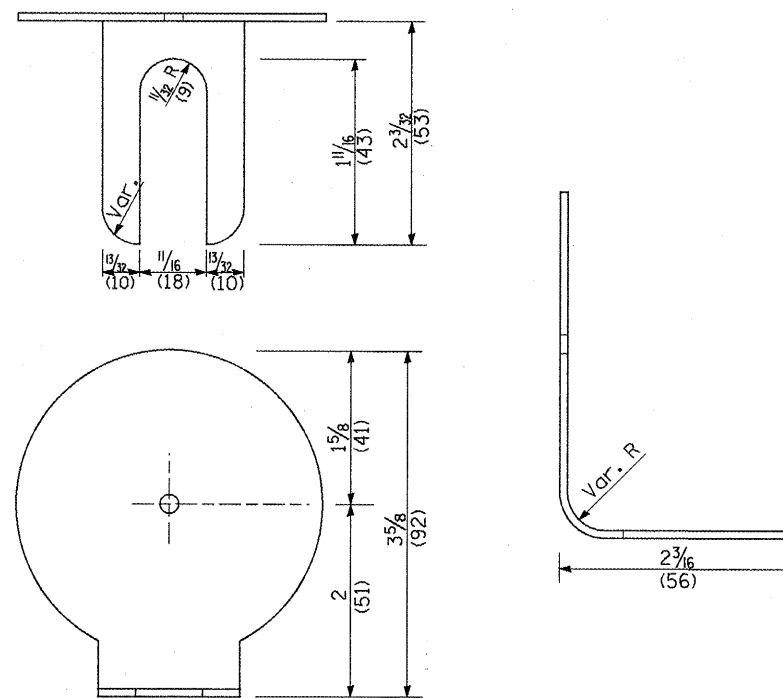

REFLECTOR MARKER TYPE A

Min. reflective area 6 1/2 sq. in. (4,194 mm<sup>2</sup>) each side. May be rectangular or slight trapezoid.

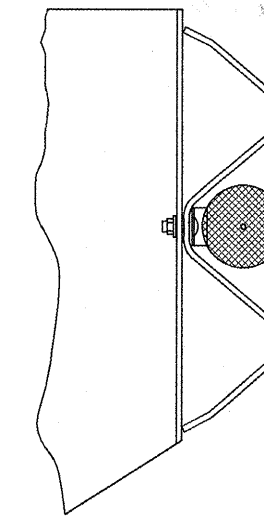

TYPICAL GUARDRAIL MOUNTING WITH REFLECTOR MARKER TYPE A

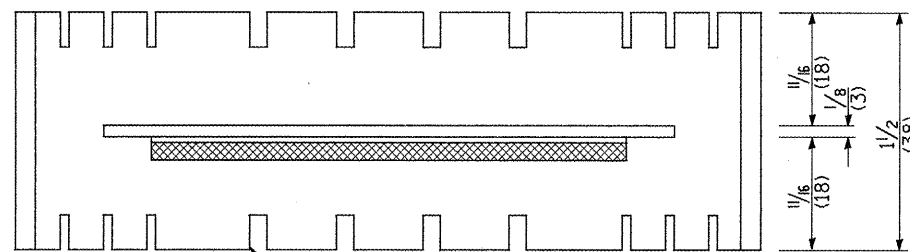

Adhesive weep slots or holes equally spaced on both sides

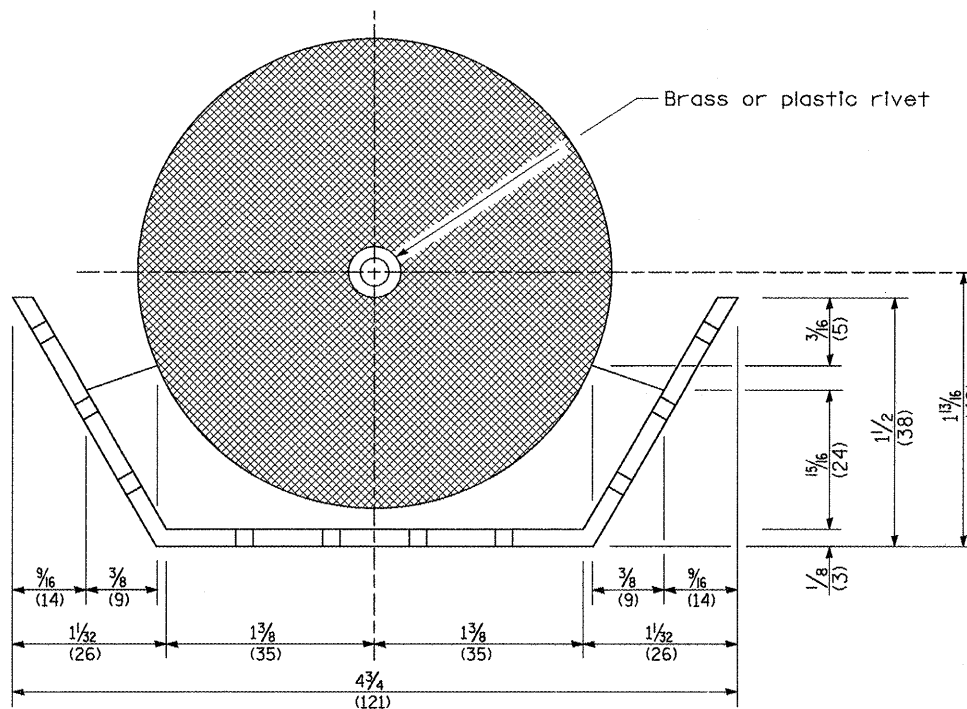

REFLECTOR MARKER TYPE B

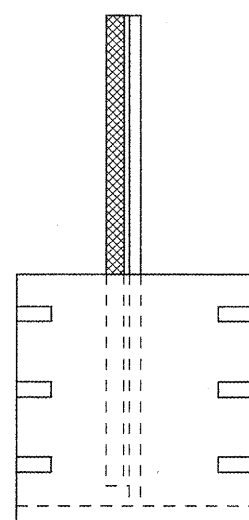

3 min. adhesive weep holes or slots each side, variable spacing.

REFLECTOR MARKER TYPE C

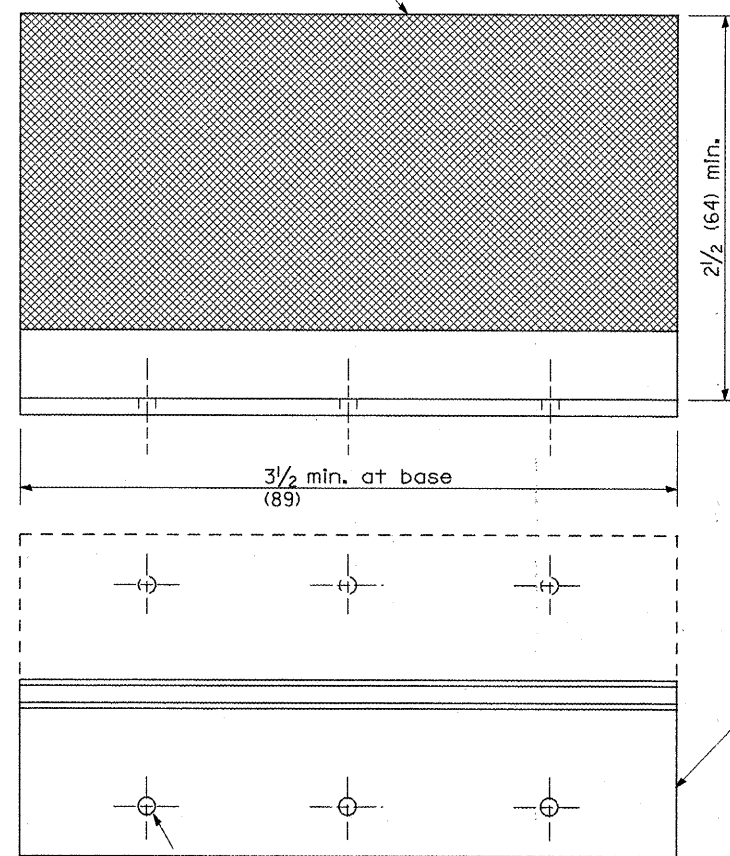

Minimum total area of base 7.0 Sq. in. (4,516 mm<sup>2</sup>)

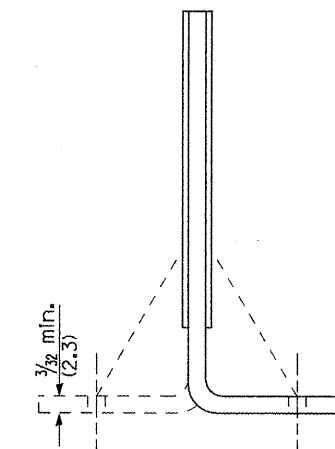

Cross section may be "T" or "L" shaped and may have side supports at ends.

REFLECTORS

All dimensions are in inches (millimeters) unless otherwise noted.

F.A.P. RTE.	SECTION	COUNTY	TOTAL SHEETS	SHEET NO.
673	**	TAZE/WOOD	60	60
FED. ROAD DIST. NO. ILLINOIS FED. AID PROJECT			CONTRACT NO. 68920	