

F.A.P. RTE.	SECTION	COUNTY	TOTAL SHEETS	SHEET NO.
840	122 R5-4	VERMILION	42	42

TO BE INSTALLED IN RIGID OR COMPOSITE PAVEMENT FOR PRESERVING LAND SURVEY MONUMENTS (SECTION OR SUBSECTION CORNERS)

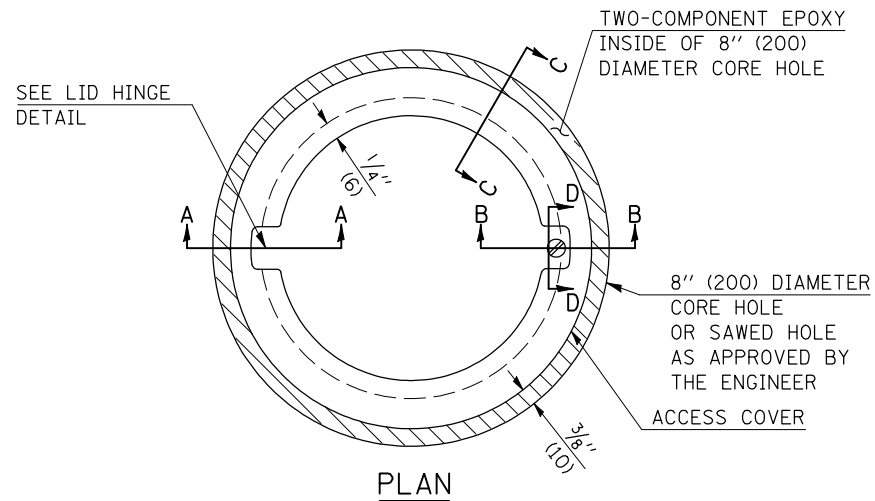

**LEGEND**

- ALUMINUM CASTING
- 5" (125) OR 6" (150) P.V.C. PIPE
- TWO-COMPONENT EPOXY

T = THICKNESS OF PAVEMENT STRUCTURE  
 H = THE THICKNESS OF THE SUB-BASE GRANULAR + 1" (25)

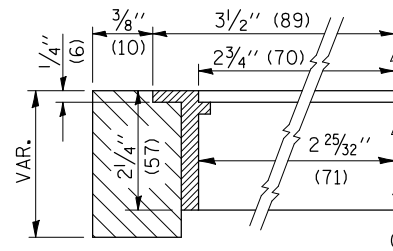

SECTION C-C

SPECIFICATIONS FOR ACCESS COVER FOR USE WITH SURVEY MARKER VAULT(S) AND SURVEY MARKER COVER ASSEMBLY(S): THE ACCESS COVER WILL BE CAST FROM A SPECIAL ALUMINUM ALLOY THAT IS COMPARABLE TO BRONZE IN HARDNESS. THE ACCESS COVER SHALL BE SPECIALLY ENGINEERED AND DESIGNED TO PROVIDE A SNUG FIT, INCORPORATING EQUIDISTANT LOCKING RIDGES, INSIDE A STANDARD 6" (150 mm) DIAMETER, OR OUTSIDE A STANDARD 5" (125 mm) DIAMETER, SCHEDULE 40 PVC PIPE. THE ACCESS COVER SHALL HAVE SPECIAL UNIFORM 1" (25 mm) THICK TOP SURFACE TO PERMIT INFORMATION TO BE EASILY MACHINE-STAMPED INTO IT. THE ACCESS COVER SHALL INCLUDE A STAINLESS CAPTURED SCREW AND AN OPPOSING RECESSED HINGE ASSEMBLY AS ITS LOCKING MECHANISM. THE ACCESS COVER SHALL INCORPORATE A SPECIAL ACCESS HOLE FOR CLEANING AND DRAINAGE, DRILLED AT 30° INSIDE THE RING OF THE ACCESS COVER, TO THE DRILLED AND TAPPED HOLE PROVIDED FOR THE STAINLESS CAPTURED SCREW. COMPOSITION: ALUMINUM 92-93%; MAGNESIUM 6.5-7.5%. STRENGTH: YIELD - 19,000-21,000 PSI (131-145 MPa); TENSILE - 38,000-44,000 PSI (262-303 MPa); ELONGATION - 10-15% IN 2" (50 mm). SPECIFICATIONS: ALLOY 535.0; Q0-A-601Es. NO EXCEPTIONS.

RE-BAR-SURVEY MARKER, TYPE I, (SPECIAL) TO BE FURNISHED BY THE CONTRACTOR AND SET BY AN ILLINOIS PROFESSIONAL LAND SURVEYOR (SEE SPECIAL DETAIL SHEET FOR ALUMINUM TABLET AND RE-BAR SPECIFICATIONS).

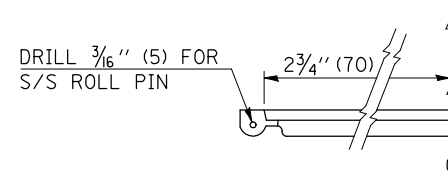
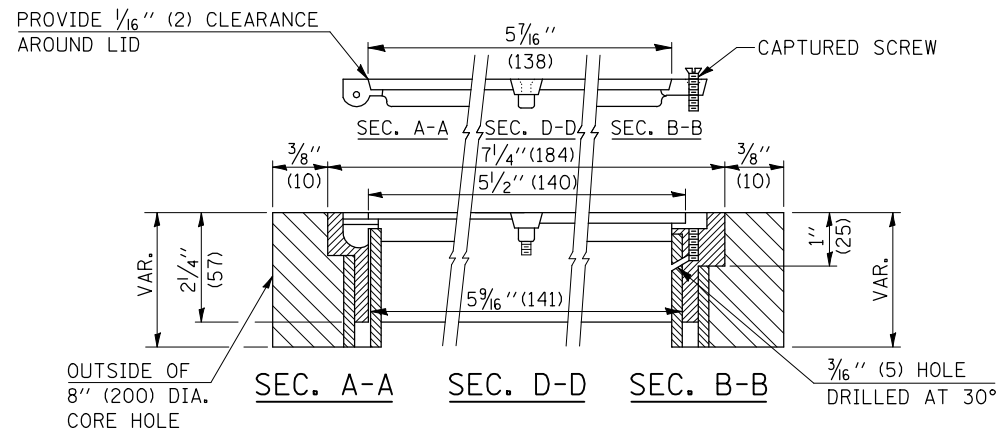

LID HINGE DETAIL

**BILL OF MATERIAL**

ALUMINUM CASTING OF THE DIMENSIONS AND SPECIFICATIONS SHOWN OR OTHER SUBJECT TO ENGINEER'S APPROVAL OF SHOP DRAWINGS, 5" OR 6" (125 mm OR 150 mm) DIAMETER P.V.C. PIPE, SCHEDULE 40, ALUMINUM TABLET, STAMPED IN ACCORDANCE WITH STANDARD 667101. 5/8" X 48" (#15 X 1.2 m ) RE-BAR, EPOXY AND FA-01/02 AGGREGATE.

**GENERAL NOTES**

- ALUMINUM CASTING SHALL BE EITHER PLACED OVER A 5" (125 mm) P.V.C. PIPE OR INSIDE OF A 6" (150 mm) P.V.C. PIPE.
- BACKFILL WITH FINE AGGREGATE - FA-01/02.
- WORK SHALL NOT START ON THIS ITEM UNTIL THE FINAL LIFT OF SURFACE HAS BEEN COMPLETED.
- THIS WORK WILL BE PAID FOR AT THE CONTRACT UNIT PRICE EACH FOR SURVEY MARKER VAULT WHICH PRICE SHALL INCLUDE ALL LABOR AND MATERIAL AS SPECIFIED INCLUDING CORING, EPOXY AND FA-01/02 AGGREGATE AND NO ADDITIONAL COMPENSATION WILL BE ALLOWED.
- THE CASTING SHALL BE ANCHORED IN THE 8" (200 mm) DIAMETER CORE HOLE WITH TWO-COMPONENT EPOXY CONFORMING TO APPLICABLE PORTIONS OF ARTICLE 1025.01 OF THE STANDARD SPECIFICATIONS.
- ALL SURVEY MARKER (VAULTS) SHALL BE PLACED 1/4" (6 mm) ± BELOW THE FINAL SURFACE.
- THE 8" (200 mm) DIAMETER CORE HOLE SHALL BE SUBJECT TO THE APPROVAL OF THE ENGINEER.

Note: All dimensions are in INCHES (millimeters) unless otherwise shown.

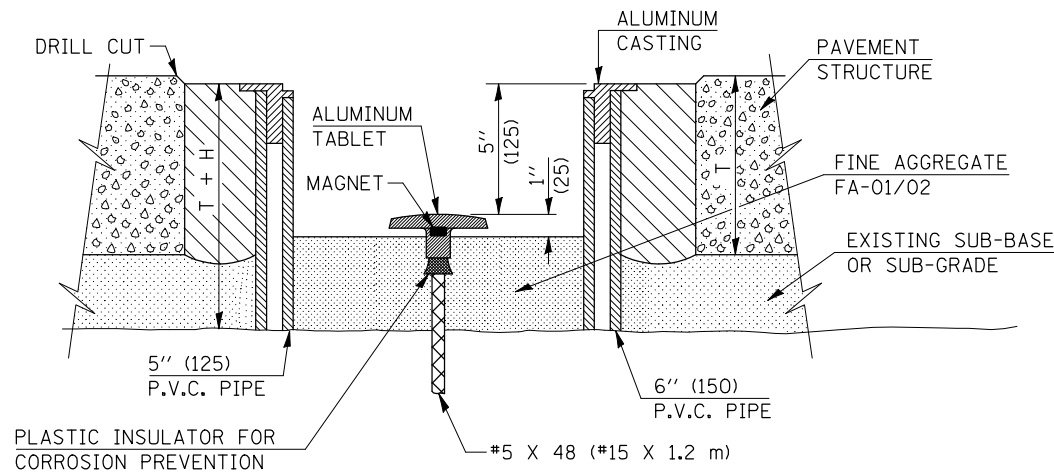

ELEVATION

DATE	REVISIONS	NAME	ILLINOIS DEPARTMENT OF TRANSPORTATION
11/06	REPLACED DETAIL D-1.04	TJB	<b>SURVEY MARKER VAULT</b>
			<b>DISTRICT 5 DETAIL NO. X0301232</b>

PLOT DATE = 1/25/2010  
 FILE NAME = c:\pvc\work\p1001\BUCKLES\11\10124902\planhsts.dgn  
 PLOT SCALE = 42,362% / IN.  
 USER NAME = buckles11