

STATE OF ILLINOIS
DEPARTMENT OF TRANSPORTATION

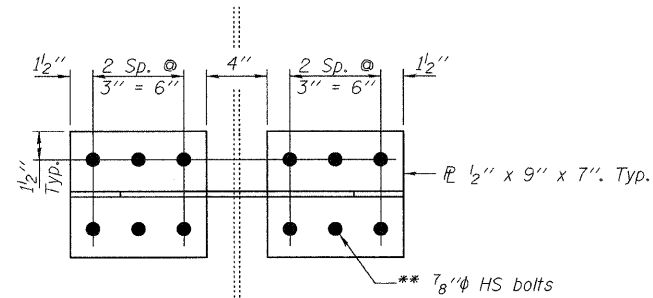

ELEVATION

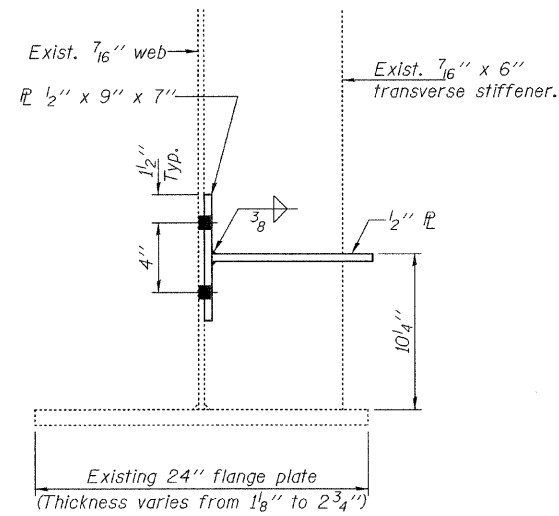

SECTION A-A

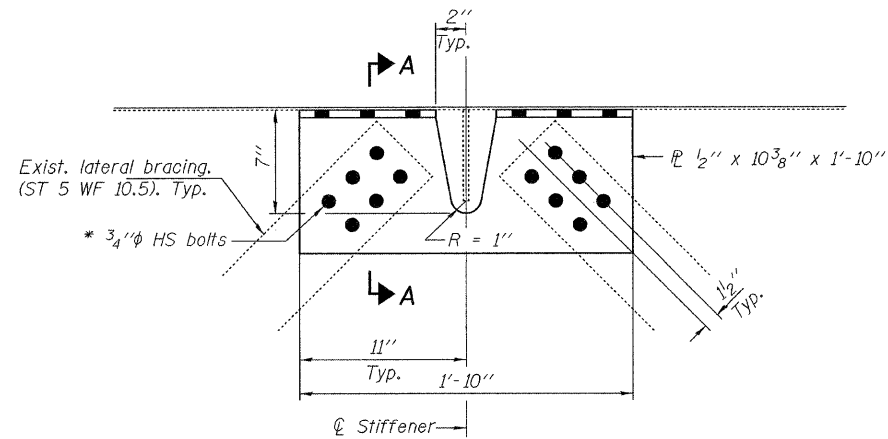

PLAN

REPAIR A
(6 req'd.)

- * Use holes in existing lateral bracing as a template for drilling holes on new plate.
- ** Use holes in new 1/2" x 7" P as a template for drilling holes in existing web.

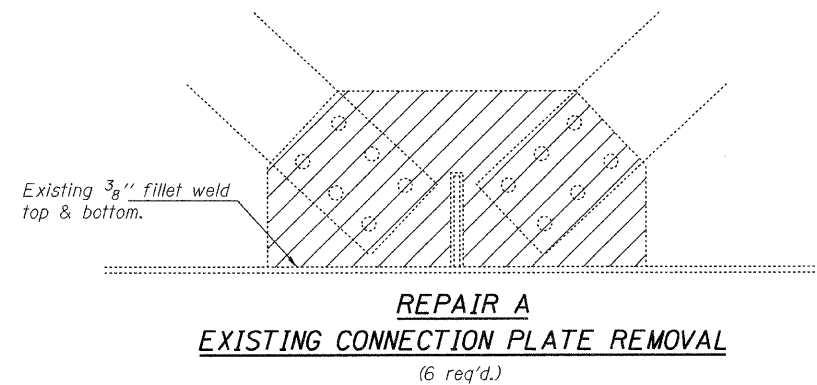

Procedure for Lateral Bracing Retrofit Detail:
(Cost included with Structural Steel Repair)

1. Remove existing 1/2" connecting plate. The minimum distance from cut to face of web shall be the larger of 1/4" or web to plate weld size, with removal of remaining material by grinding as described below. The cut shall be made parallel to the web without angling the cut towards the web. Equipment and method of cutting shall be approved by the Engineer. Any method of removal to be used shall ensure that no damage is done to the existing web, vertical stiffener or welds connecting these elements. Cutting shall be done in a manner such that the paint on the opposite face of the web is not damaged. If damage occurs, the damaged area shall be repainted at the contractor's expense and procedures shall be modified to prevent damage at subsequent removal locations.

2. Remove material between cut and web by grinding and grind smooth at web surface. Web plate surfaces shall have a roughness average (Ra) of 250µin. or less. Grinding equipment shall be approved by the Engineer. The grinding operation should not gouge the girder web plate.

3. The web surface at the modification shall be inspected using dye penetrant or magnetic particle (MT) methods. Any cracks found shall be identified and reported to the Bureau of Bridges and Structures for further disposition.

DESIGNED	ATH
CHECKED	VHV
DRAWN	balva
CHECKED	ATH VHV

FEBRUARY 26, 2010
 EXAMINED *A. Carl Boyer*
 ENGINEER OF STRUCTURAL SERVICES
 PASSED *Ralph E. Anderson*
 ENGINEER OF BRIDGES AND STRUCTURES

REPAIR DETAILS
SBI RT. 3
OVER THE KASKASKIA RIVER
SN 079-0036

SHEET NO. 21	SBI RTE.	SECTION	COUNTY	TOTAL SHEETS	SHEET NO.
	3	73-BR-II	RANDOLPH	51	44
22 SHEETS	CONTRACT NO. 76883				
FED. ROAD DIST. NO.		ILLINOIS FED. AID PROJECT			