

| TEMPORARY DITCH CHECKS SCHEDULE | | |
|---------------------------------|------------|-------------------------------|
| STATION | OFFSET | TEMPORARY DITCH CHECKS (FOOT) |
| 16+15.78 | 175.76' RT | 12 |
| 17+18.86 | 167.27' RT | 12 |
| 18+17.88 | 151.38' RT | 12 |
| 19+10.45 | 114.00' RT | 12 |
| 20+02.58 | 75.63' RT | 12 |
| TOTAL | | 60 |

| PERIMETER EROSION BARRIER, SPECIAL SCHEDULE | | |
|---|----------|------------|
| POINT | STATION | OFFSET |
| A | 14+37.75 | 154.68' LT |
| B | 15+30.87 | 139.11' LT |
| C | 15+37.52 | 118.83' LT |
| D | 17+17.26 | 101.95' LT |
| E | 20+60.50 | 43.56' LT |
| F | 20+94.83 | 41.97' RT |
| G | 18+71.44 | 136.71' RT |
| H | 18+75.82 | 168.42' RT |
| I | 13+98.50 | 203.08' RT |
| J | 14+01.81 | 195.22' RT |
| K | 16+36.89 | 139.44' RT |
| L | 16+44.33 | 118.96' RT |
| M | 14+64.86 | 114.17' LT |
| N | 14+69.85 | 72.79' LT |
| O | 14+59.52 | 69.51' LT |
| P | 14+61.25 | 54.60' LT |
| Q | 14+32.08 | 46.65' LT |
| R | 14+13.29 | 91.44' LT |
| S | 12+29.82 | 21.16' LT |
| T | 12+20.77 | 46.66' LT |
| U | 12+41.55 | 55.82' LT |
| V | 12+08.18 | 114.49' LT |
| W | 11+90.80 | 106.37' LT |
| X | 11+95.36 | 94.69' LT |
| Y | 10+83.31 | 51.81' LT |
| Z | 10+24.34 | 193.59' LT |
| AA | 12+40.98 | 199.53' LT |
| BB | 12+59.97 | 149.60' LT |
| CC | 13+31.18 | 177.72' LT |
| TOTAL LENGTH = | | 3284' |

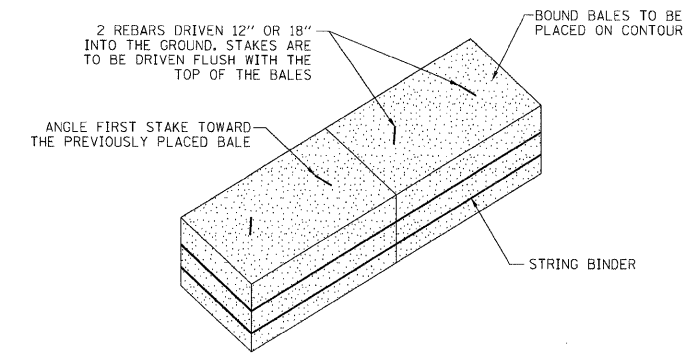

PERIMETER EROSION BARRIER, SPECIAL

NOTES

- 1. NO EXCAVATION CAN BE MADE ON THIS PARCEL.

LEGEND

- PROPOSED 1-1/2" ASPHALT OVERLAY, MIX "C", N70
- EXISTING CONCRETE TO REMAIN
- TEMPORARY DITCH CHECK

