

ELEVATION VIEW

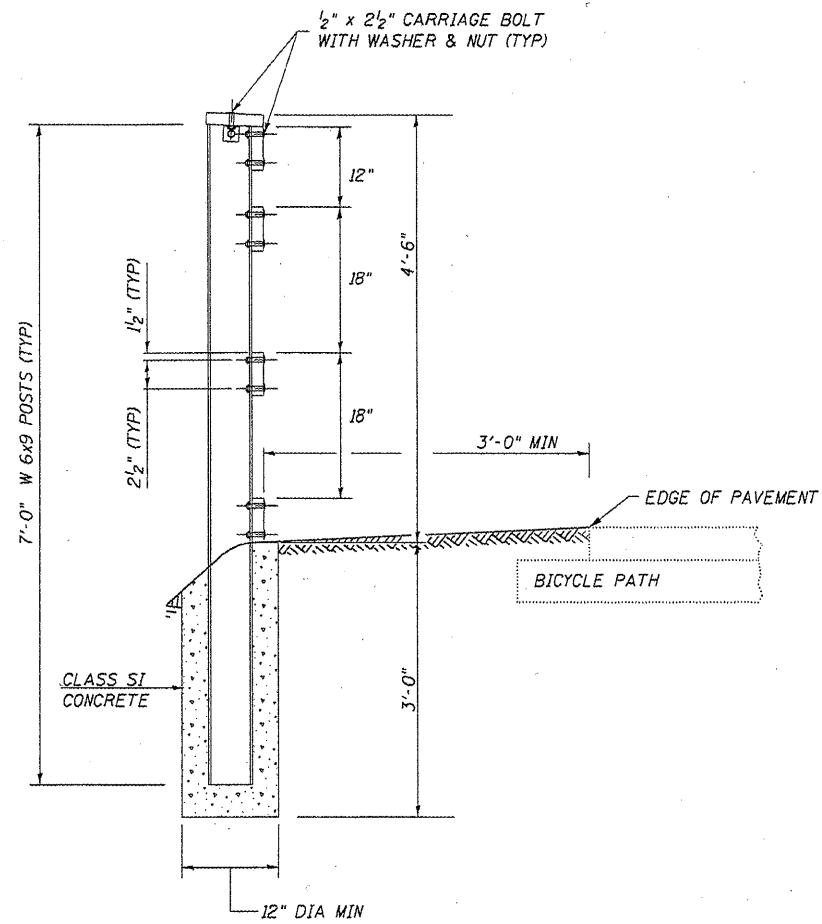

SECTION A-A

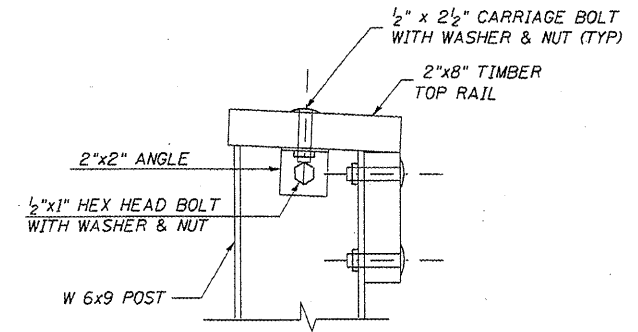

TOP RAIL CONNECTION DETAIL

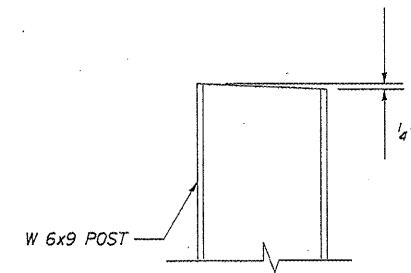

TOP OF POST DETAIL

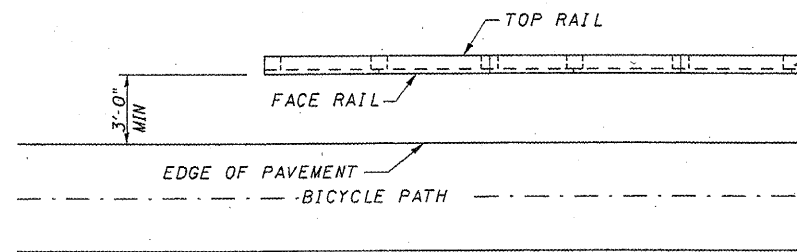

PLAN VIEW

1. STEEL POSTS SHALL BE AS SPECIFIED IN ARTICLE 1006.23.
2. ALL HARDWARE SHALL BE AS SPECIFIED IN ARTICLE 1006.25.
3. TIMBER RAILS SHALL BE TREATED SOUTHERN PINE AS SPECIFIED IN ARTICLE 1007.03 ( $f_b = 1500 \text{ psi}$ ).
4. STAGGER ALTERNATING BUTT ENDS ON FACE RAIL AND TOP RAIL. CENTER ALL BUTT END JOINTS ON THE POSTS.

Revised 4-13-10

CUMMINS  
ENGINEERING  
CORPORATION

JOB = 2192	DESIGNED - NAK	REVISED -
FILE NAME = 2192det11s.dgn	DRAWN - AJH	REVISED -
PLOT SCALE = 100.000 / IN.	CHECKED - NAK	REVISED -
PLOT DATE = 4/12/2010	DATE - 1/22/2009	REVISED -

SANGAMON VALLEY TRAIL

TIMBER BICYCLE RAILING

F.A.S. RTE.	SECTION	COUNTY	TOTAL SHEETS	SHEET NO.
	05-00173-00-BT	SANGAMON	173	64
FED. ROAD DIST. NO.			ILLINOIS FED. AID PROJECT	
			CONTRACT NO. 93522	