

STATE OF ILLINOIS
DEPARTMENT OF TRANSPORTATION

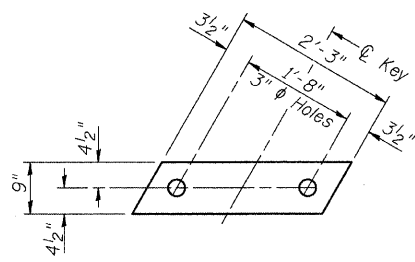

FABRIC BEARING PAD
(Interior)

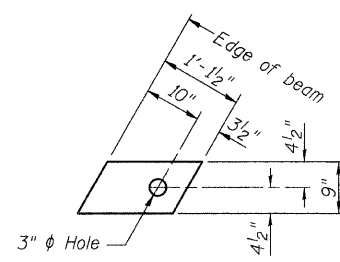

FABRIC BEARING PAD
(Exterior)

FIXED

Note: All bearing pads shall be 1" thick.

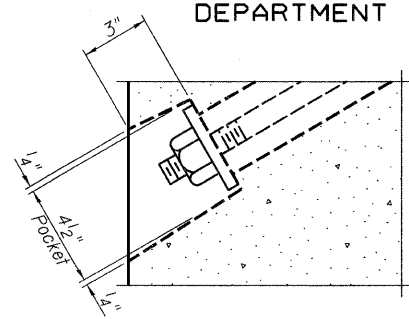

SECTION A-A

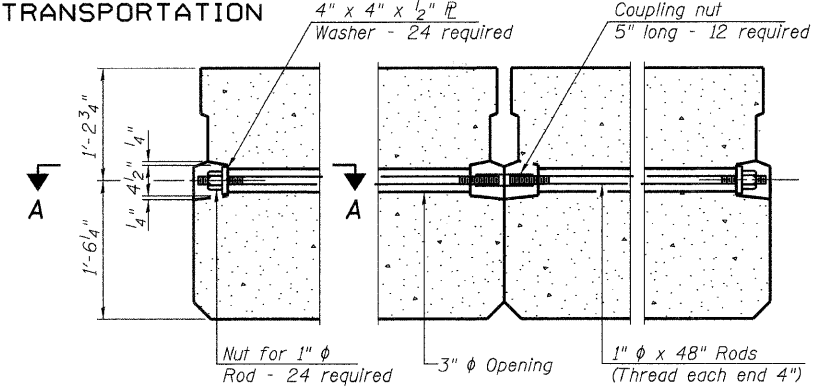

TYPICAL TRANSVERSE TIE ASSEMBLY

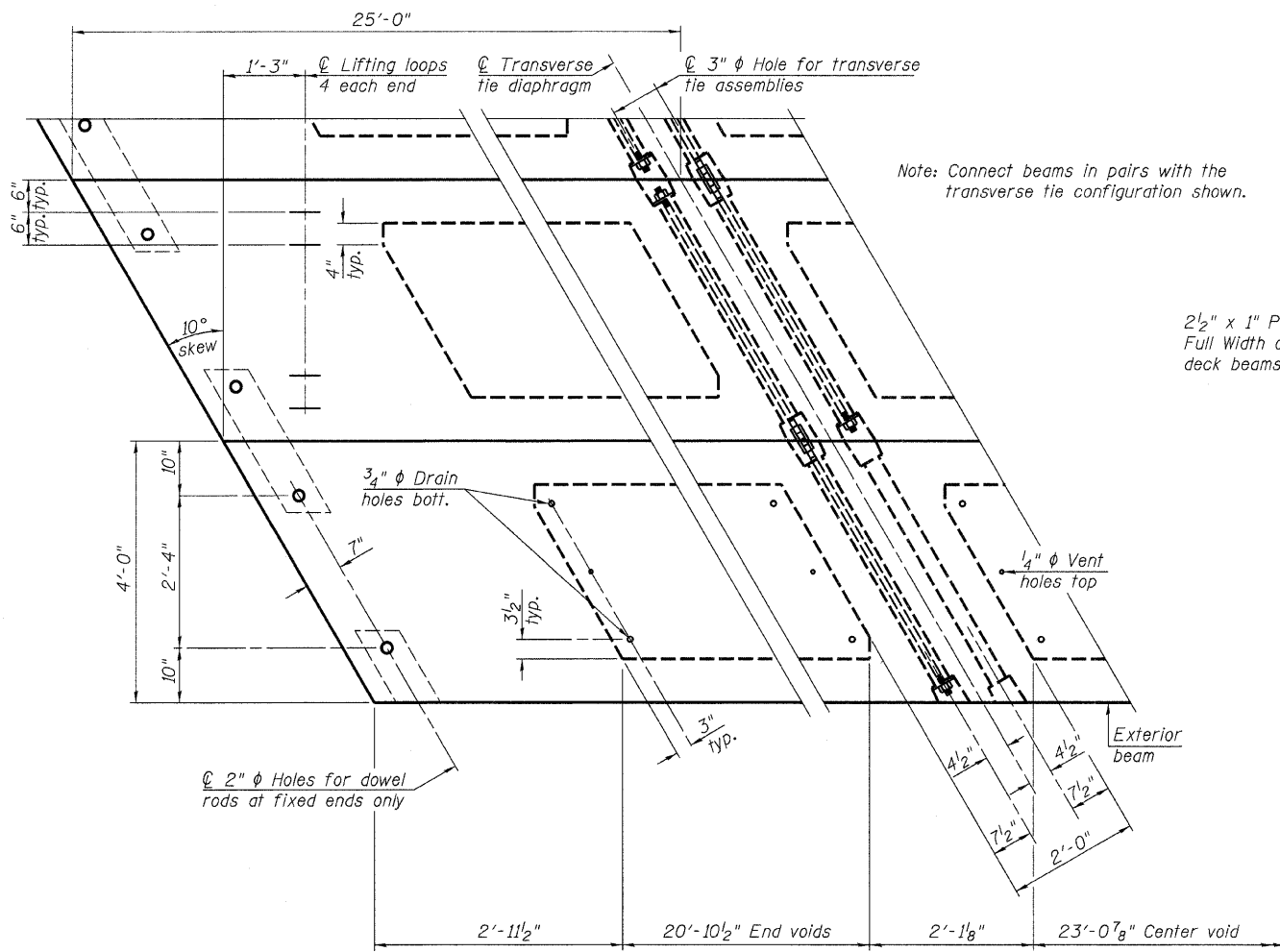
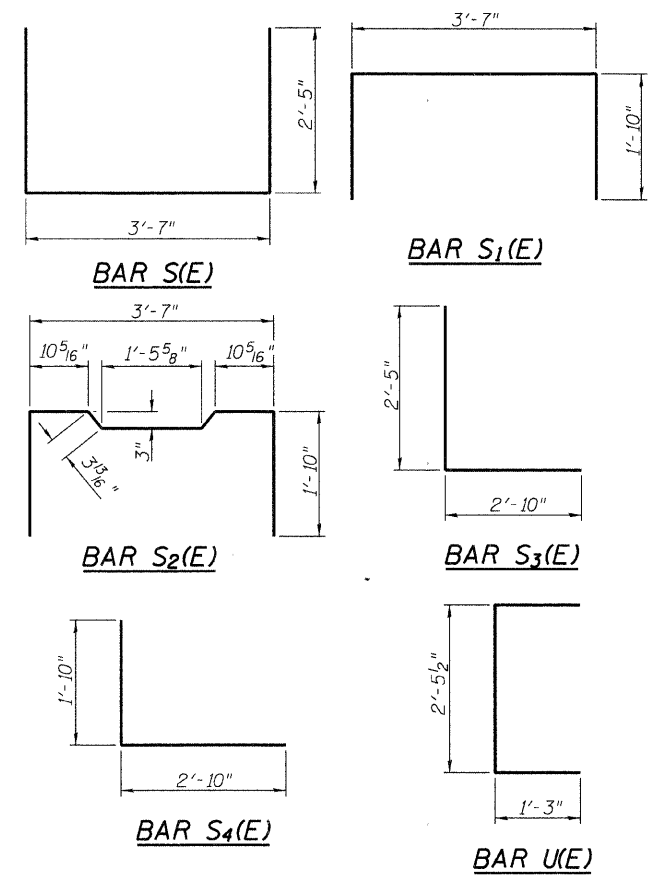

PLAN VIEW

Note: Connect beams in pairs with the transverse tie configuration shown.

2 1/2" x 1" P.J.F. Full Width of bridge deck beams

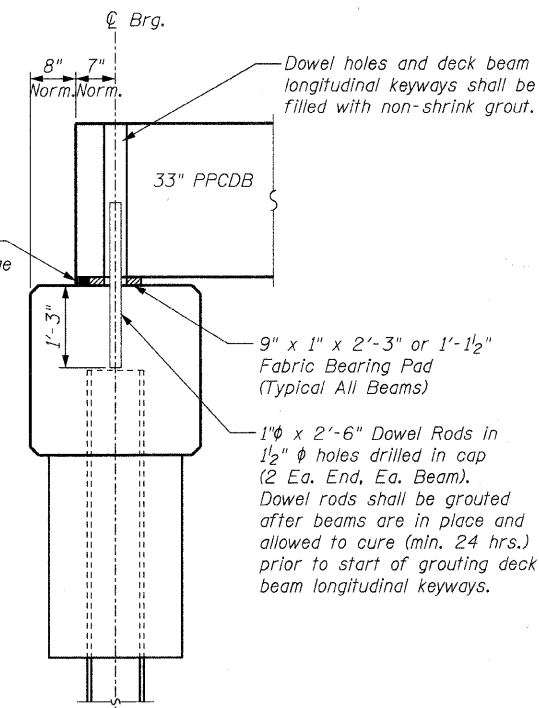

FIXED BEARING ABUTMENT

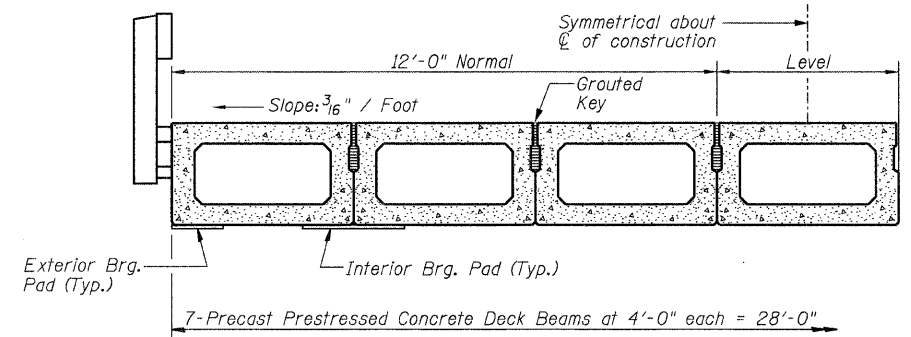

HALF CROSS SECTION

See Sheet 8 for the details showing the spacing and mounting of posts and rails to the PPCDB.

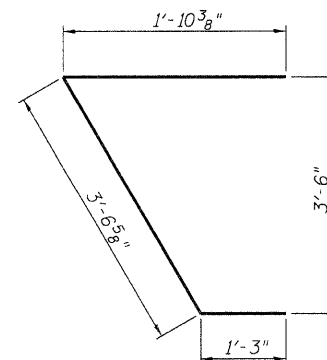

BAR U₁(E)

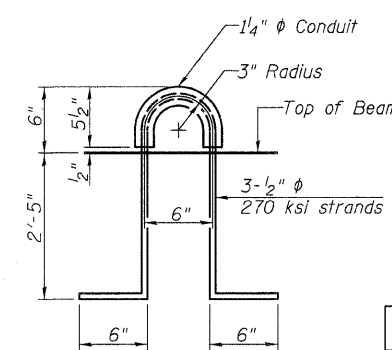

LIFTING LOOP DETAIL

BILL OF MATERIAL

Precast Prestressed Conc. Deck Bms. (33" depth)	Sq. Ft.	2105
---	---------	------

**33" X 48" PPC DECK BEAM DETAILS
STRUCTURE NO. 040-3259**

ROUTE	SECTION	COUNTY	TOTAL SHEETS	SHEET NO.
TR 39	07-04124-00-BR	JASPER	9	7
CONTRACT NO. 95622				
FED. ROAD DIST. NO. 7 ILLINOIS FED. AID PROJECT				

02/10/2010 RAAI #51109

PD-3348-RD

11-1-09

NOTES

Prestressing steel shall be uncoated high strength, low relaxation 7-wire strand, Grade 270. The nominal diameter shall be 1/2" and the nominal cross-sectional area shall be 0.153 sq. in. The 1" rods in the transverse tie assembly shall be tightened to a snug fit and the threads set. Pockets on exterior faces of bridge shall be filled with grout after transverse tie assembly is in place.

Reinforcement bars shall conform to ASTM A 706, Grade 60. (See Special Provisions).

Two 1/8" fabric adjusting shims of the dimensions of the exterior bearing pad shall be provided for each bearing pad location.

A minimum 2 1/2" lifting pin shall be used to engage the lifting loops during handling.

Corrosion Inhibitor, per Article 1020.05(b)(12) and 1021.06 of the Standard Specifications, shall be used in the concrete for precast prestressed concrete deck beams.

Compressive strength of prestressed concrete, f'c, shall be 6000 psi.

Compressive strength of prestressed concrete at release, f'ci, shall be 5000 psi.