

F.A.U. ROUTE	SECTION	COUNTY	TOTAL SHEETS	SHEET NUMBER
9168	05-00035-00-FP 05-00056-00-FP	ST. CLAIR	60	37
STA. 24+17.37		TO	STA. 79+10.00	
FEDERAL AID PROJECT			CONTRACT 97360	

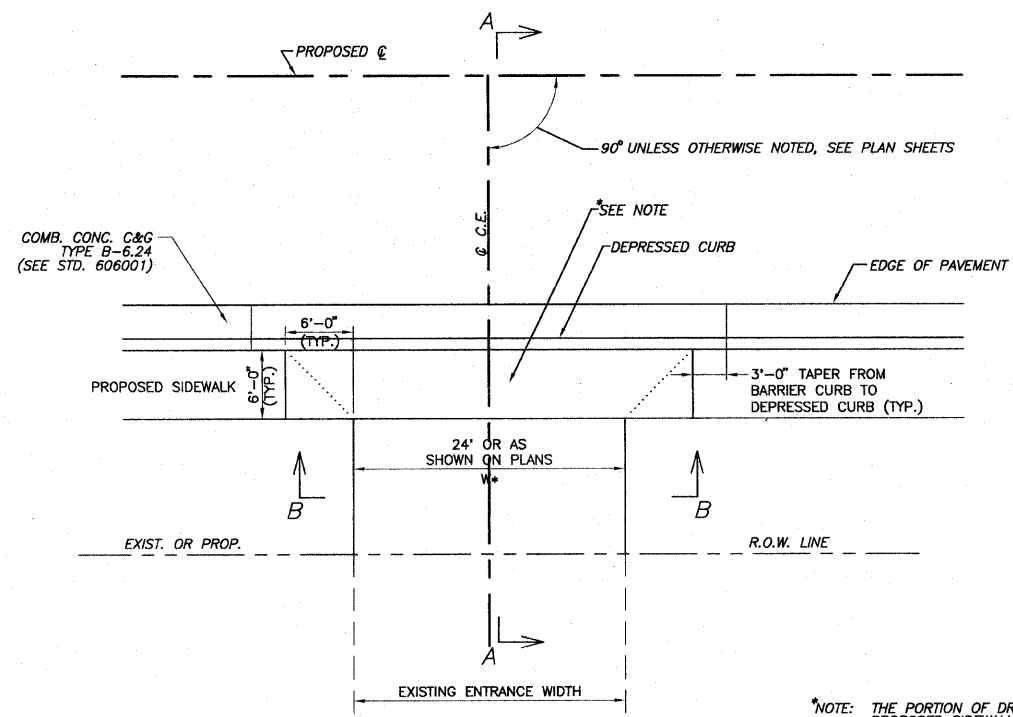

C.E. DETAIL "A"
 COMMERCIAL ENTRANCE WITH SIDEWALK ADJACENT TO ROADWAY PAVEMENT AND CONCRETE CURB & GUTTER TYPE B-6.24
 N.T.S.
 STA. 24+50 TO STA. 35+00

NOTE: THE PORTION OF DRIVEWAY PAVEMENT ALONG ALIGNMENT OF THE PROPOSED SIDEWALK SHALL BE POURED SEPARATELY FROM THE REMAINDER OF THE DRIVEWAY PAVEMENT AND GROOVED WITH THE SAME SPACING AS THE ADJACENT SIDEWALK. THIS WORK SHALL BE PAID FOR AS PCC DRIVEWAY PAVEMENT, 6".

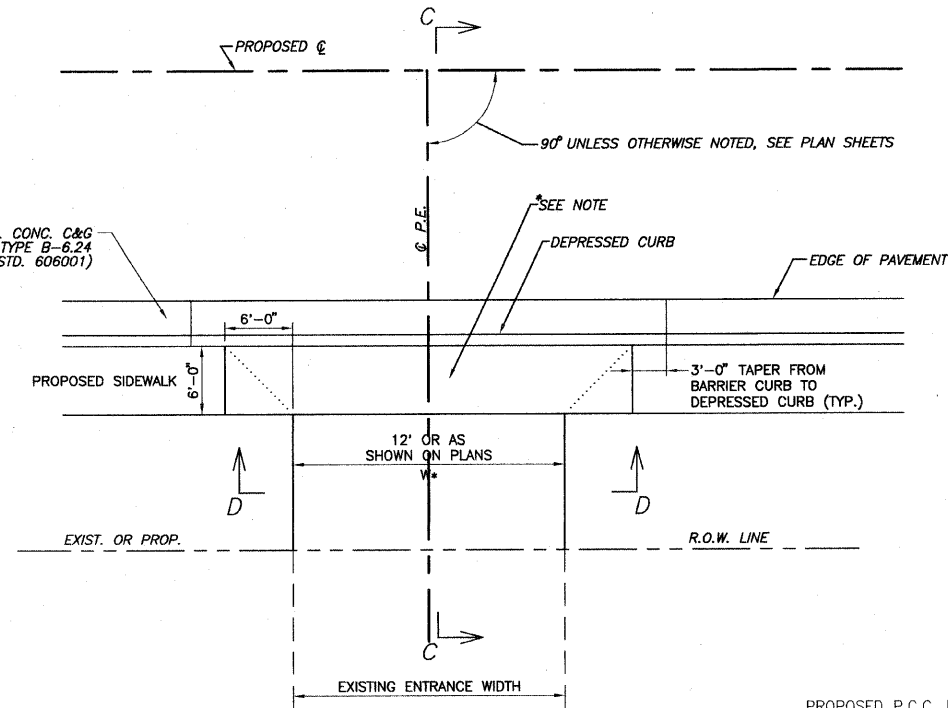

P.E. DETAIL "B"
 PRIVATE ENTRANCE WITH SIDEWALK ADJACENT TO ROADWAY PAVEMENT AND CONCRETE CURB & GUTTER TYPE B-6.24
 N.T.S.
 STA. 24+50 TO STA. 35+00 &
 LT. STA. 48+92.31**

** NOTE: ENTRANCE AT STATION 48+92.31 LT. HAS 2' BUFFER FROM BACK OF CURB TO EDGE OF SIDEWALK.

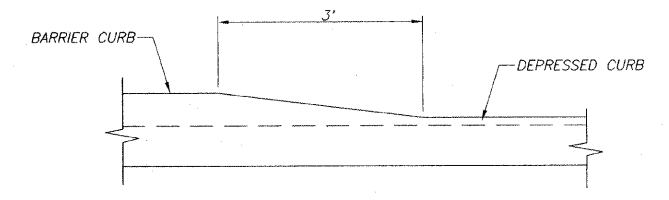

DETAIL OF CURB HEIGHT TRANSITION
 N.T.S.

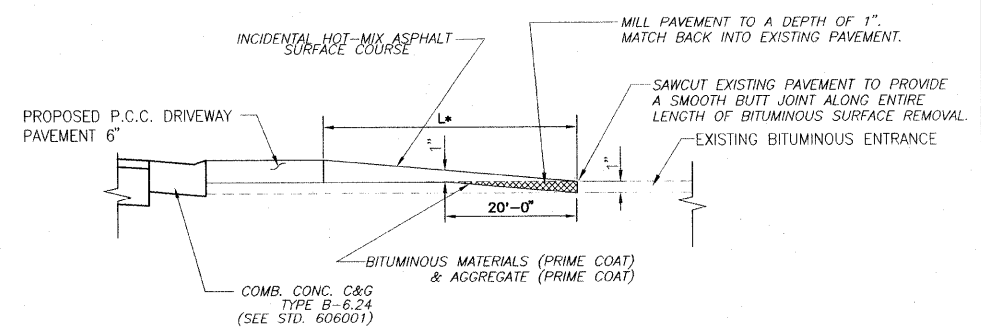

BUTT JOINT DETAIL
 N.T.S.
 ANDRIA'S RESTURANT MATCH BACK INTO EXISTING PAVEMENT TYPICAL BUTT JOINT DETAIL

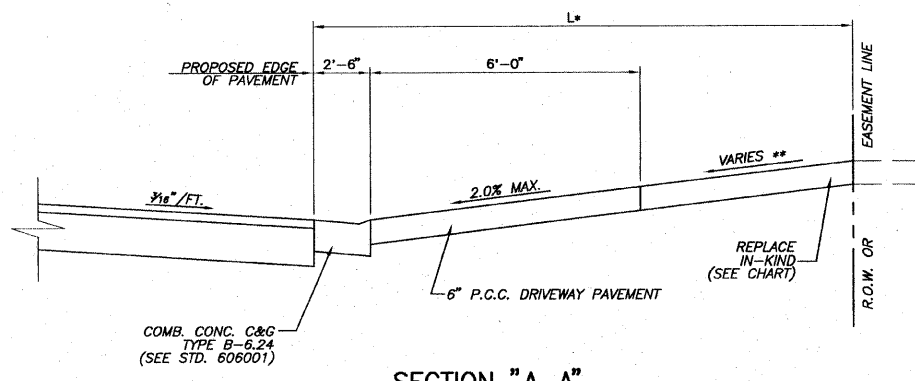

SECTION "A-A"
 * SEE ENTRANCE SCHEDULE FOR DISTANCES
 ** SEE CROSS SECTIONS FOR SLOPES

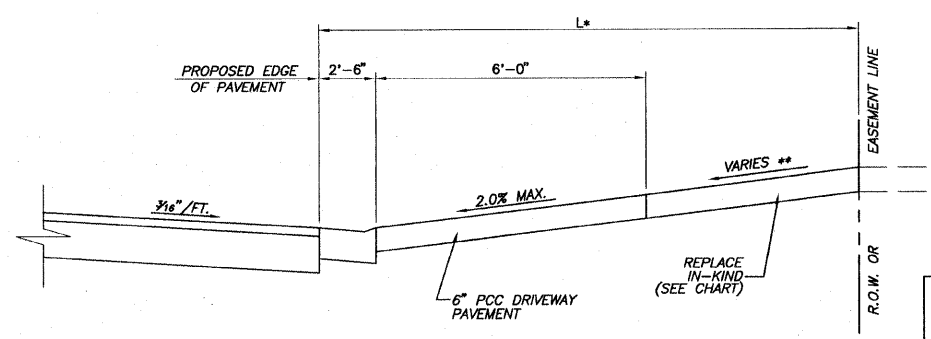

SECTION "C-C"
 * SEE ENTRANCE SCHEDULE FOR DISTANCES
 ** SEE CROSS SECTIONS FOR SLOPES

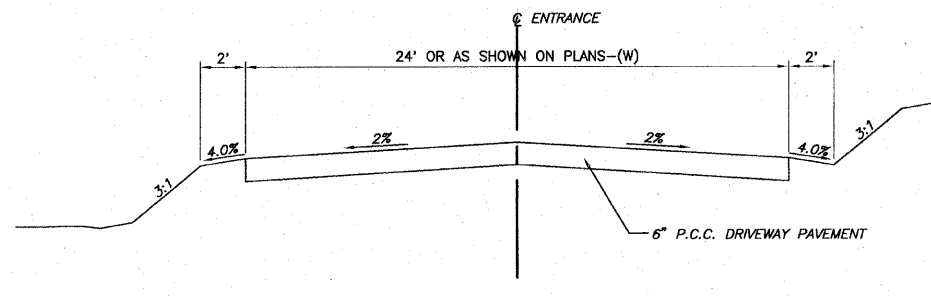

SECTION "B-B"

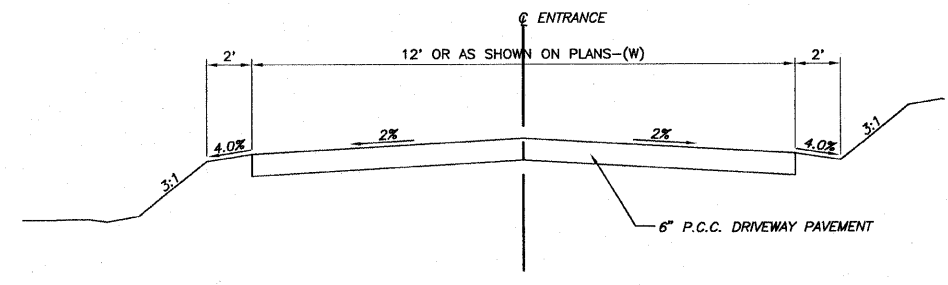

SECTION "D-D"

TYPE OF ENTRANCE	EXISTING MATERIAL	NEW ENTRANCE MATERIAL (BEYOND RADIUS RETURNS OR TAPERS)			
		PCC DRIVEWAY PAVEMENT 6"	INCIDENTAL HOT-MIX ASPHALT SURFACING 3"	AGGREGATE BASE COURSE TYPE B, 8"	AGGREGATE SURFACE COURSE TYPE B, 6"
PRIVATE & COMMERCIAL	CONCRETE	X			
	BITUMINOUS		X	X	
	AGGREGATE				X