

INDEX OF SHEETS

SHEET NO.	DESCRIPTION
1	TITLE SHEET & SUMMARY OF QUANTITIES
2	PLAN & PROFILE, TYPICAL SECTIONS, GENERAL NOTES & STONE RIPRAP DITCH DESIGN
3-4	ROADWAY CROSS SECTIONS
5-12	BRIDGE DESIGN

THE FOLLOWING STANDARDS ARE A PART OF THESE PLANS AND ARE INCLUDED IN THE PROPOSAL:

000001-05	STANDARD SYMBOLS, ABBREVIATIONS & PATTERNS
280001-05	TEMPORARY EROSION CONTROL SYSTEMS
515001-03	NAME PLATE FOR BRIDGES
542101-02	REINFORCED CONCRETE END SECTIONS FOR PIPE CULVERTS 15" THRU 36" DIA. AT RIGHT ANGLES WITH ROADWAY
BLR 26-2	STEEL PLATE BEAM GUARDRAIL
701901-01	TRAFFIC CONTROL DEVICES
B.L.R. 21-8	TYPICAL APPLICATION OF TRAFFIC CONTROL DEVICES FOR CONSTRUCTION ON RURAL LOCAL HIGHWAYS
B.L.R. 22-6	TYPICAL APPLICATION OF TRAFFIC CONTROL DEVICES FOR CONSTRUCTION ON RURAL LOCAL HIGHWAYS (TWO-LANE TWO-WAY RURAL TRAFFIC) (ROAD CLOSED TO THRU TRAFFIC)
B.L.R. 23-3	TRAFFIC BARRIER TERMINAL TYPE 1
B.L.R. 27-1	TRAFFIC BARRIER TERMINAL TYPE 5A

SUMMARY OF QUANTITIES

CODE NO.	ITEM	UNIT	QUANTITY
20100500	TREE REMOVAL, ACRES	ACRE	0.10
20200100	EARTH EXCAVATION	CU YD	132.00
20300100	CHANNEL EXCAVATION	CU YD	245.00
20400800	FURNISHED EXCAVATION	CU YD	727.00
* 25001000	SEEDING, CLASS 2 (SPECIAL)	ACRE	0.40
28000305	TEMPORARY DITCH CHECKS	FOOT	12.00
28001000	AGGREGATE (EROSION CONTROL)	TON	16.00
28100807	STONE DUMPED RIPRAP, CLASS A4	TON	405.00
28102600	STONE RIPRAP DITCH	TON	32.00
40200800	AGGREGATE SURFACE COURSE, TYPE B	TON	390.00
50100100	REMOVAL OF EXISTING STRUCTURES	EACH	1.00
50300225	CONCRETE STRUCTURES	CU YD	23.00
50300280	CONCRETE ENCASEMENT	CU YD	2.80
50400405	PRECAST PRESTRESSED CONCRETE DECK BEAMS (21" DEPTH)	SQ FT	1200.00
50800105	REINFORCEMENT BARS	POUND	2500.00
△ 50900205	STEEL RAILING, TYPE S1	FOOT	106.00
51201400	FURNISHING STEEL PILES 10X42	FOOT	280.00
51202305	DRIVING PILES	FOOT	280.00
51500100	NAME PLATES	EACH	1.00
542A0229	PIPE CULVERTS, CLASS A, TYPE 1 24"	FOOT	32.00
542D0217	PIPE CULVERTS, CLASS D, TYPE 1 12"	FOOT	80.00
54213669	PRECAST REINFORCED CONCRETE FLARED END SECTIONS 24"	EACH	1.00
54215424	CAST-IN-PLACE REINFORCED CONCRETE END SECTIONS 24"	EACH	1.00
△ 63000005	STEEL PLATE BEAM GUARD RAIL, TYPE B	FOOT	112.00
△ 63100075	TRAFFIC BARRIER TERMINAL, TYPE 5A	EACH	3.00
* 67100100	MOBILIZATION	L SUM	1.00
△ LR631020	TRAFFIC BARRIER TERMINAL, TYPE 1	EACH	3.00

△ SPECIALTY ITEMS

DESIGN DESIGNATION:
DESIGN SPEED: 30 MPH
HIGHWAY CLASS - LOCAL ROAD
EXISTING STRUCTURE NO.: 097-3064
PROPOSED STRUCTURE NO.: 097-3256
CURRENT A.D.T. = 80
CONTRACT NO. 99373

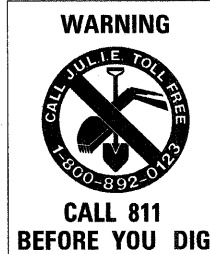

STATE OF ILLINOIS

DEPARTMENT OF TRANSPORTATION

DIVISION OF HIGHWAYS

PLANS FOR PROPOSED HIGHWAY BRIDGE PROGRAM

T.R. 128 WHITE COUNTY SECTION 06-08134-00-BR

PROJECT NO. BROS-193(30) JOB NO. C-99-542-06

CONTRACT # 99373 CREEK

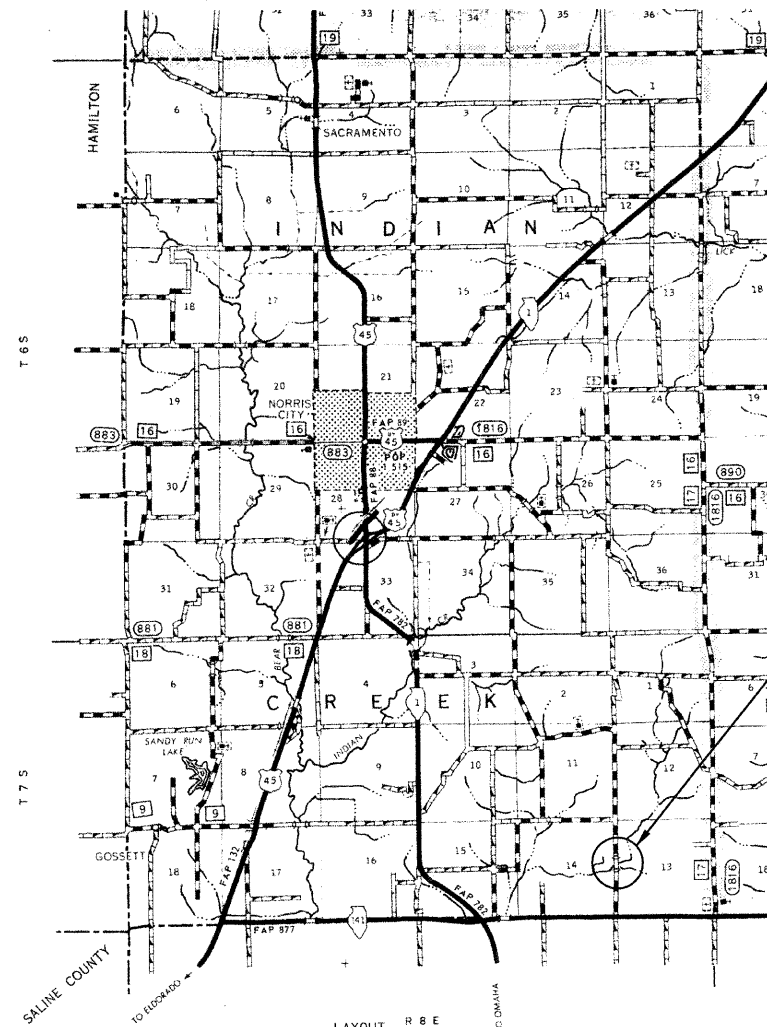

	FEET	MILES
GROSS LENGTH	575.00 FT	0.109 MILES
OMISSIONS	0.00 FT	0.000 MILES
NET LENGTH	575.00 FT	0.109 MILES

PLAN	1" = 50'	
PROFILE	1" = 50'	
PROFILE VERT.	1" = 5'	
CROSS SECTION	1" = 5'	

SECTION 06-08134-00-BR
BEGINS STATION 2+25

STATION 5+00, STRUCTURE NO. 097-3256
A 50' LONG SINGLE SPAN PRECAST PRESTRESSED
CONCRETE DECK BEAM BRIDGE (21" DEPTH),
24' ROADWAY, 0.00% GRADE, 15° RT. FWD. SKEW.

SECTION 06-08134-00-BR
ENDS STATION 8+00

STATE OF ILLINOIS
DEPARTMENT OF TRANSPORTATION

APPROVED January 13, 2010
Brian A. Ryan
COUNTY ENGINEER

PASSED FEBRUARY 1, 2010
Dennis W. Hillebrand
ENGINEER OF LOCAL ROADS AND STREETS

RELEASING FOR BID
BASED ON LIMITED
REVIEW: Feb 4, 2010
Mary C. Lamie
MARY C. LAMIE, P.E.
DEPUTY DIRECTOR OF HIGHWAYS
REGION FIVE ENGINEER

TR	SECTION	COUNTY	TOTAL SHEETS	SHEET NO.
128	06-08134-00-BR	WHITE	12	1

FED. ROAD DIST. NO. 9 ILLINOIS FED. AID PROJECT
PROJECT# BROS-193(30) CONTRACT# 99373
JOB # C-99-542-06 CREEK
LEC JOB # H081014NH

323 W. 3RD ST.
P.O. BOX 160
MT. CARMEL, IL
62863
PHONE:
(618)-262-8651
FAX:
(618)-263-3327

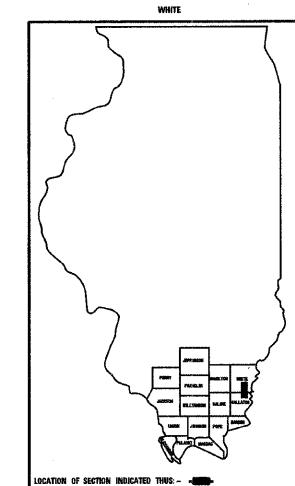

405 W. STATE ST
SUITE 1
PRINCETON, IN
47670
PHONE:
(812)-386-7611
FAX:
(812)-385-2812



PROFESSIONAL DESIGN FIRM
LAND SURVEY &
PROFESSIONAL
ENGINEERING
CORPORATION
184-00887
(62-032435)(35-002769)



AARON M. MEFFORD
NAME
Aaron M. Mefford
SIGNATURE
1-13-10
DATE
11-30-11
EXPIRES

TOWNSHIP ROUTE 128
OVER CREEK
WHITE COUNTY, ILLINOIS

SHEET TITLE:	
TITLE SHEET	
SCALE:	VARIABLE
BY:	AMM
DATE:	10/10
REV:	
1	OF 12
SHEETS	
SHEET NO.	
1	

GENERAL NOTES:

THIS SECTION SHALL BE CONSTRUCTED IN ACCORDANCE WITH THE PLANS, SPECIAL PROVISIONS AND "STANDARD SPECIFICATIONS FOR ROAD AND BRIDGE CONSTRUCTION", ADOPTED JANUARY 1, 2007.

THE WORK INVOLVED ON THIS SECTION CONSISTS OF THE REMOVAL OF THE EXISTING STRUCTURE, THE CONSTRUCTION OF A 50 FOOT LONG SINGLE SPAN PRECAST, PRESTRESSED CONCRETE DECK BEAM BRIDGE, EARTH APPROACHES, AGGREGATE SURFACE COURSE AND OTHER MISCELLANEOUS ITEMS NECESSARY TO COMPLETE THIS SECTION.

ALL ELEVATIONS ARE BASED ON U.S.G.S. MEAN SEA LEVEL DATUM.

IT SHALL BE THE CONTRACTOR'S RESPONSIBILITY TO CONTACT ALL THE UTILITIES, AFFECTING THE PROJECT, PRIOR TO CONSTRUCTION.

TANK CARS SHALL REMAIN THE PROPERTY OF THE TOWNSHIP.

TYPICAL CROSS SECTION PROPOSED

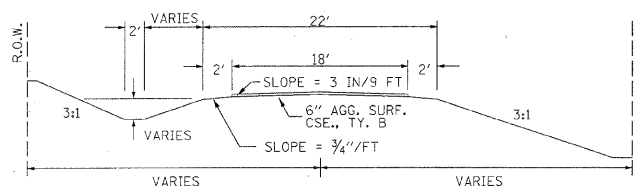

TYPICAL CROSS SECTION EXISTING

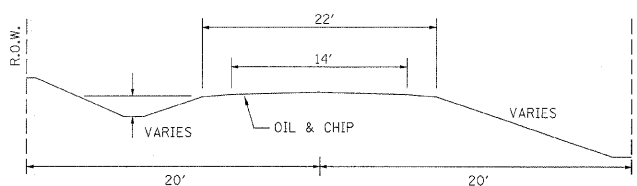

PRIVATE ENTRANCE DETAIL

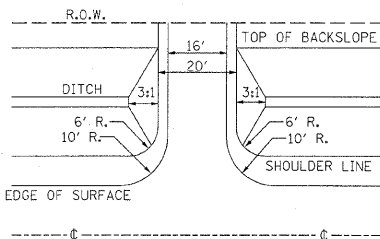

NOTE: CONSTRUCT SPECIAL DITCH

STA 2+25 TO STA 2+80 LT
STA 2+25 TO STA 4+10 RT
STA 5+18 TO STA 8+00 LT
STA 6+50 TO STA 8+00 RT

NOTE: CONSTRUCT STONE RIPRAP DITCH

STA 4+34 TO STA 4+54 RT (0.62 TON/LIN FT)
STA 5+18 TO STA 5+50 LT (0.62 TON/LIN FT)
32 TON STONE RIPRAP DITCH ALLOWED IN PROPOSAL.
SEE STONE RIPRAP DITCH DETAIL.

NOTE: TRAFFIC BARRIER TERMINAL 5A

STA 4+57.84 TO STA 4+71.09 LT

NOTE: STEEL PLATE BEAM GUARDRAIL TYPE B

STA 3+45.84 TO STA 4+57.84 LT

NOTE: TRAFFIC BARRIER TERMINAL TYPE 1

STA 3+20.84 TO STA 3+45.84 LT

STONE RIPRAP DITCH DESIGN

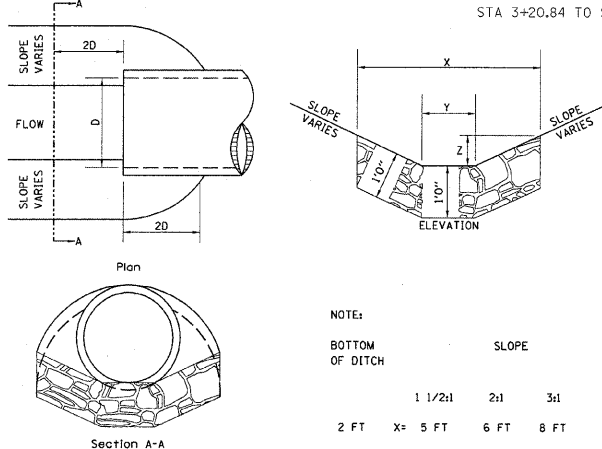

NOTE:

BOTTOM OF DITCH	SLOPE		
	1 1/2h	2h	3h
2 FT	X = 5 FT	6 FT	8 FT
	Y = 2 FT	2 FT	2 FT
	Z = 1 FT	1 FT	1 FT
	0.40	0.48	0.62 TON/LIN, FT

NOTE: FOR PLACEMENT, QUALITY GRADATION AND OTHER MISCELLANEOUS REQUIREMENTS FOR STONE RIPRAP DITCH-SEE SPECIAL PROVISIONS.

UTILITIES:

- J.U.L.I.E. 1-800-892-0123
- GALLATIN-WHITE WATER 1-618-962-3265
- VERIZON 1-618-395-6189
- WAYNE-WHITE ELECTRIC CO-OP 1-618-842-2196
- CONSUMERS GAS COMPANY 1-618-445-3012

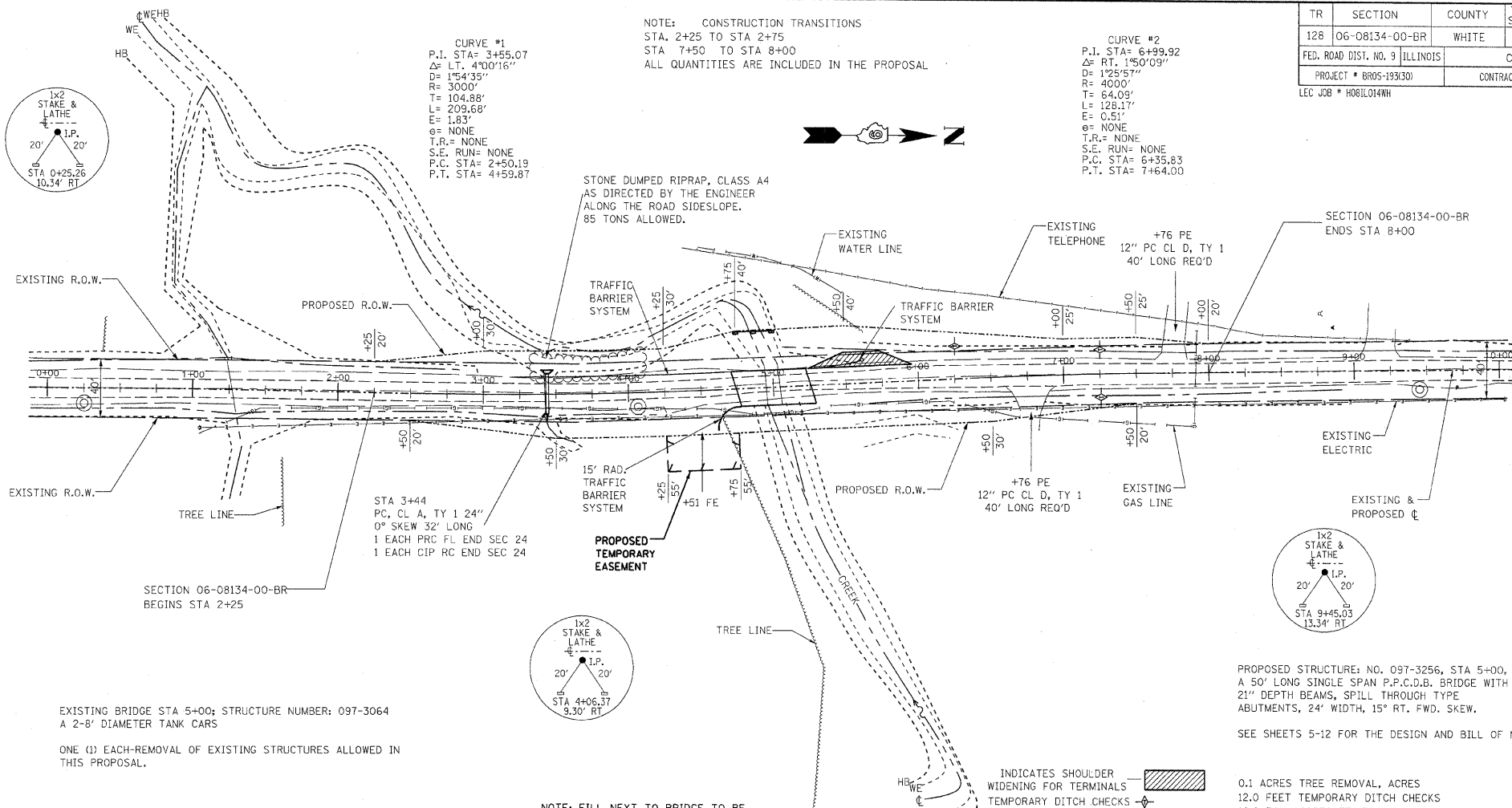

EXISTING BRIDGE STA 5+00; STRUCTURE NUMBER: 097-3064
A 2-8' DIAMETER TANK CARS

ONE (1) EACH-REMOVAL OF EXISTING STRUCTURES ALLOWED IN THIS PROPOSAL.

NOTE: FILL NEXT TO BRIDGE TO BE AGGREGATE SURFACE COURSE

INDICATES SHOULDER WIDENING FOR TERMINALS
TEMPORARY DITCH CHECKS
AGGREGATE (EROSION CONTROL)

0.1 ACRES TREE REMOVAL, ACRES
12.0 FEET TEMPORARY DITCH CHECKS
16.0 TON AGGREGATE (EROSION CONTROL)
0.4 ACRES SEEDING, CLASS 2 SPECIAL REQUIRED

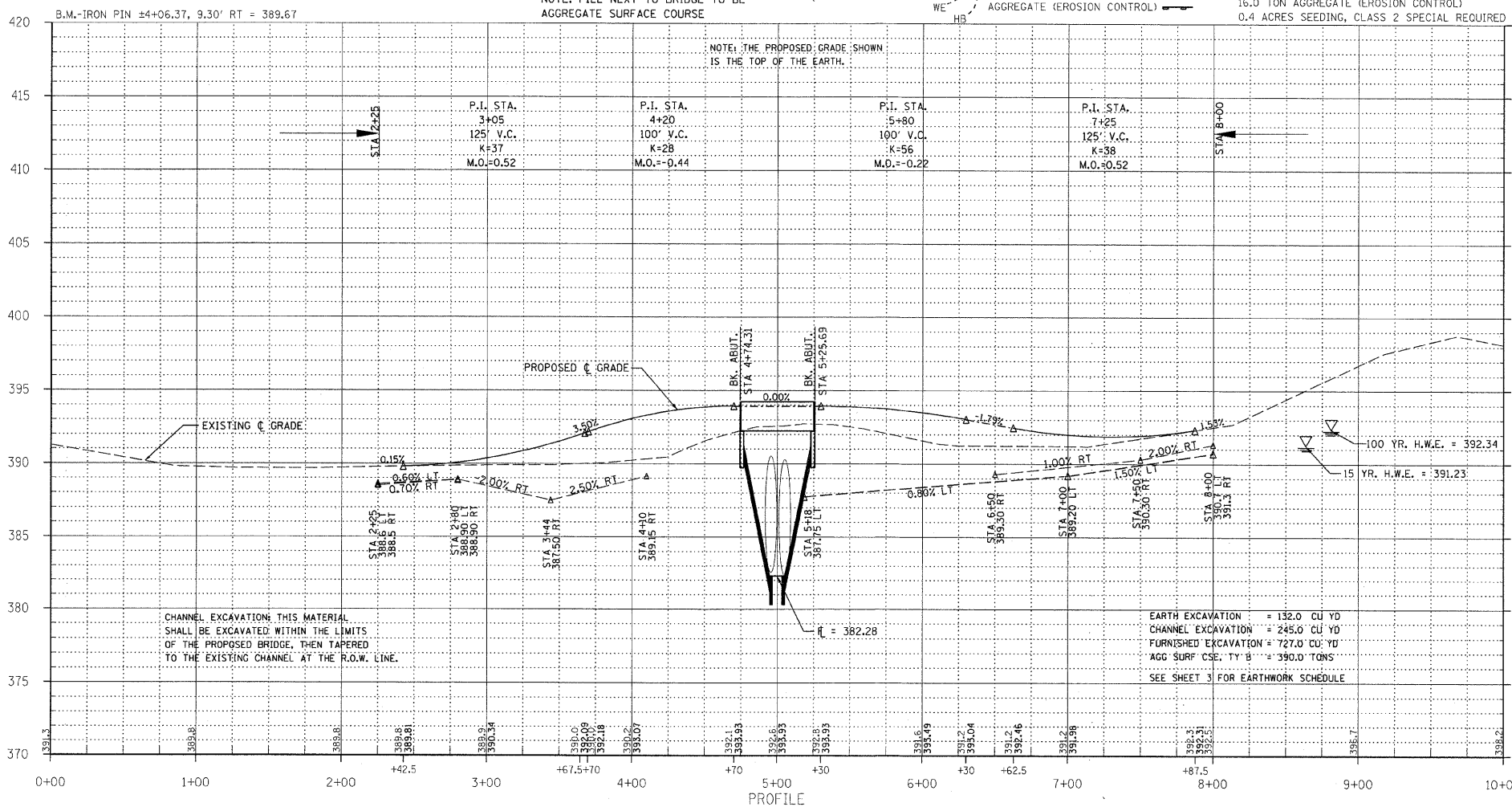

CHANNEL EXCAVATION: THIS MATERIAL SHALL BE EXCAVATED WITHIN THE LIMITS OF THE PROPOSED BRIDGE, THEN TAPERED TO THE EXISTING CHANNEL AT THE R.O.W. LINE.

EARTH EXCAVATION = 132.0 CU YD
CHANNEL EXCAVATION = 245.0 CU YD
FURNISHED EXCAVATION = 727.0 CU YD
AGG SURF CSE, TY B = 390.0 TONS
SEE SHEET 3 FOR EARTHWORK SCHEDULE

NOTE: CONSTRUCTION TRANSITIONS
STA. 2+25 TO STA 2+75
STA 7+50 TO STA 8+00
ALL QUANTITIES ARE INCLUDED IN THE PROPOSAL

CURVE #2
P.I. STA= 6+99.92
Δ= RT, 150°09'
D= 125.57'
R= 4000'
T= 64.09'
L= 128.17'
E= 0.51'
e= NONE
T.R.= NONE
S.E. RUN= NONE
P.C. STA= 6+35.83
P.T. STA= 7+64.00

CURVE #1
P.I. STA= 3+55.07
Δ= LT, 40°0'16"
D= 154.35'
R= 3000'
T= 104.88'
L= 209.68'
E= 1.83'
e= NONE
T.R.= NONE
S.E. RUN= NONE
P.C. STA= 2+50.19
P.T. STA= 4+59.87

STONE DUMPED RIPRAP, CLASS A4 AS DIRECTED BY THE ENGINEER ALONG THE ROAD SIDESLOPE. 85 TONS ALLOWED.

TR	SECTION	COUNTY	TOTAL SHEETS	SHEET NO.
128	06-08134-00-BR	WHITE	12	2

PROJECT # BR05-1931301 CONTRACT # 99373

323 W. 3RD ST.
P.O. BOX 160
MT. CARMEL, IL 62863

PHONE: (618)-262-8651
FAX: (618)-263-3327

405 W. STATE ST
SUITE 100
PRINCETON, IN 47670

PHONE: (812)-386-7611
FAX: (812)-385-2812



PROFESSIONAL DESIGN FIRM
LAND SURVEY & PROFESSIONAL ENGINEERING CORPORATION
184-000887
(62-032435)(35-002769)

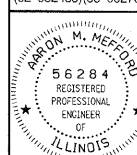

AARON M. MEFFORD

NAME

Signature

1-13-10

DATE

11-30-11

EXPIRES

TOWNSHIP ROUTE 128
OVER CREEK
WHITE COUNTY, ILLINOIS

SHEET TITLE:

PLAN & PROFILE

SCALE: VARIES

BY: AMM

DATE: 10/10

REV:

2 OF 12

SHEETS

SHEET NO.

2

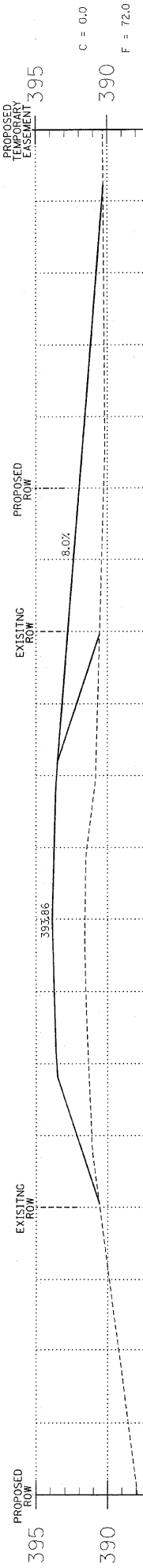

4+50

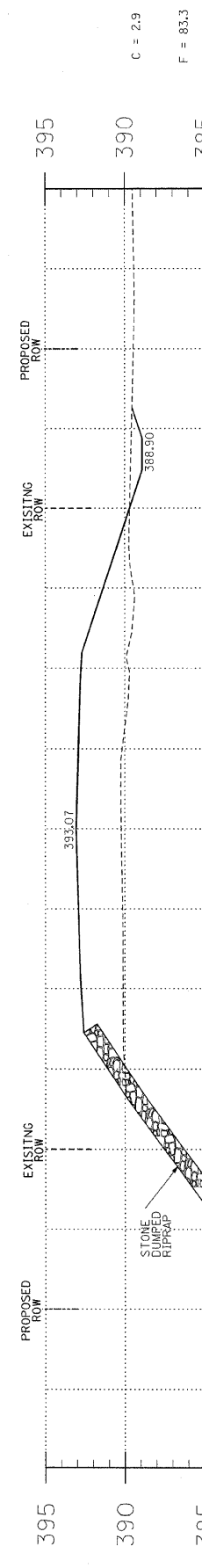

4+00

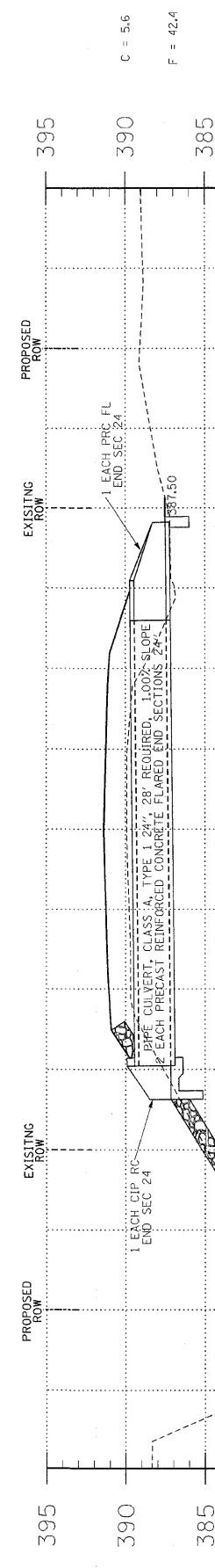

3+44

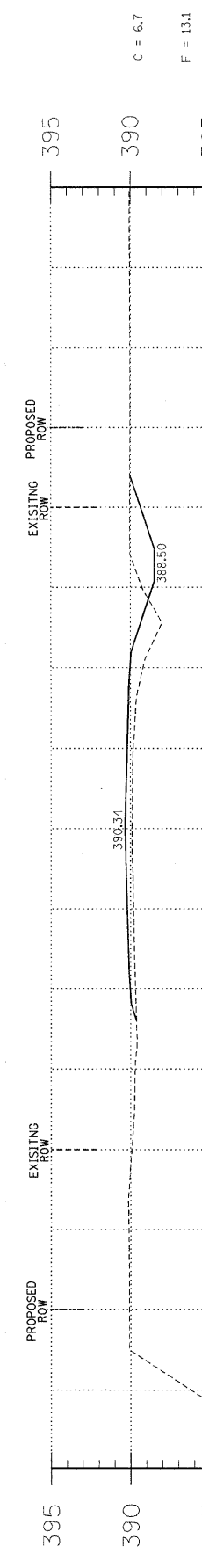

3+00

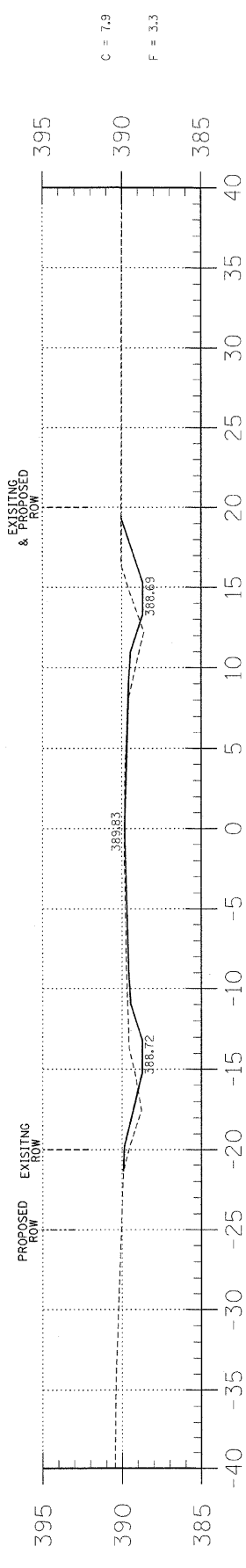

2+50

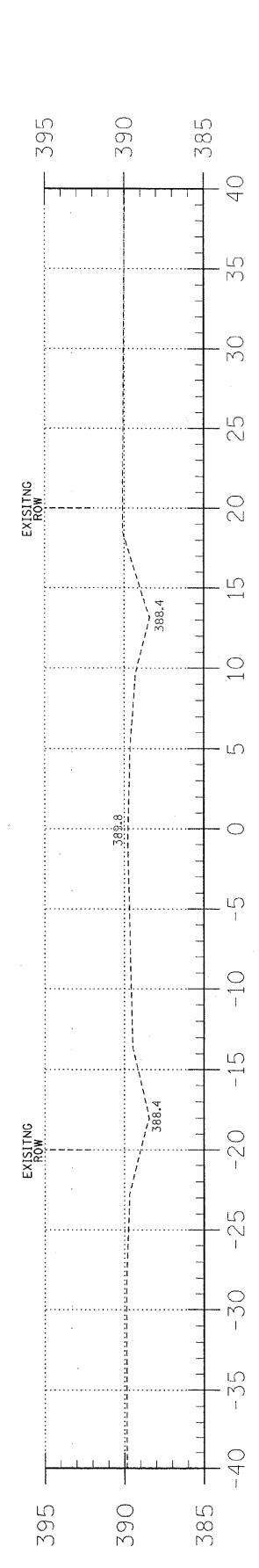

2+00

EARTHWORK SCHEDULE

LOCATION	EARTH EXCAVATION	CHANNEL EXCAVATION	ESTIMATED UNSUITABLE MATERIAL	SUITABLE MATERIAL ADJUSTED FOR SHRINKAGE	EMBANKMENT	EARTHWORK BALANCE WASTE (+) OR SHORTAGE (-)
	CUBIC YARD	CUBIC YARD	CUBIC YARD	CUBIC YARD	CUBIC YARD	CUBIC YARD
STA 0+00 TO 4+74.3	42.8	0.0	0.0	32.1	375.5	-343.4
STA 4+74.3 TO 5+25.7	0.0	245.0	122.5	92.0	0.0	+92.0
STA 5+25.7 TO 10+00	89.2	0.0	0.0	66.9	453.3	-386.4
2 PRIVATE ENTRANCE & 1 FIELD ENTRANCE	0.0	0.0	0.0	0.0	89.2	-89.2
TOTAL	132.0	245.0	122.5	191.0	918.0	-727.0

TR	SECTION	COUNTY	TOTAL SHEETS	SHEET NO.
128	06-08134-00-BR	WHITE	12	3
FED. ROAD DIST. NO. 9 ILLINOIS		CREEK		
PROJECT * BR05-193(30)		CONTRACT * 99373		
LEC JOB # HB81014WH				

323 W. 3RD ST.
P.O. BOX 160
MT. CARMEL, IL
62863
PHONE:
(618)-262-8651
FAX:
(618)-263-3327

405 W. STATE ST.
SUITE 1
PRINCETON, IN
47670
PHONE:
(812)-386-7611
FAX:
(812)-386-2812



PROFESSIONAL DESIGN FIRM
LAND SURVEY & PROFESSIONAL ENGINEERING CORPORATION
184-000887
(62-032435)(35-002769)

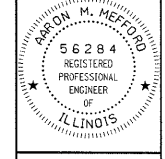

AARON M. MEFFORD
NAME
SIGNATURE
DATE
1-13-10
11-30-11 EXPIRES

TOWNSHIP ROUTE 128
OVER CREEK
WHITE COUNTY, ILLINOIS

SHEET TITLE:	
CROSS-SECTIONS	
SCALE:	1" = 5'
BY:	AMM
DATE:	10/00
REV:	
3	OF 12
SHEETS	
SHEET NO.	
3	

TR	SECTION	COUNTY	TOTAL SHEETS	SHEET NO.
128	06-08134-00-BR	WHITE	12	4
FED. ROAD DIST. NO. 9 ILLINOIS		CREEK		
PROJECT * BROS-193300		CONTRACT * 99373		

323 W. 3RD ST.
P.O. BOX 160
MT. CARMEL, IL
62863
PHONE: (618)-262-8651
FAX: (618)-263-3327

405 W. STATE ST.
SUITE 1
FRINCETON, IN
47670
PHONE: (812)-386-7611
FAX: (812)-385-2812

PHONE: (812)-386-7611
FAX: (812)-385-2812



PROFESSIONAL DESIGN FIRM
LAND SURVEY & PROFESSIONAL ENGINEERING CORPORATION
184-009897
(62-032435)(35-002769)

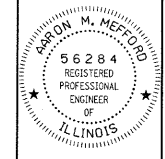

AARON M. MEFFORD
NAME
Aaron Mefford
SIGNATURE
1-13-10
DATE
11-30-11
EXPIRES

TOWNSHIP ROUTE 128
OVER CREEK
WHITE COUNTY, ILLINOIS

SHEET TITLE:

CROSS-SECTIONS

SCALE: 1" = 5'
BY: AMM
DATE: 1/8/10
REV:

4 OF 12 SHEETS

SHEET NO. 4

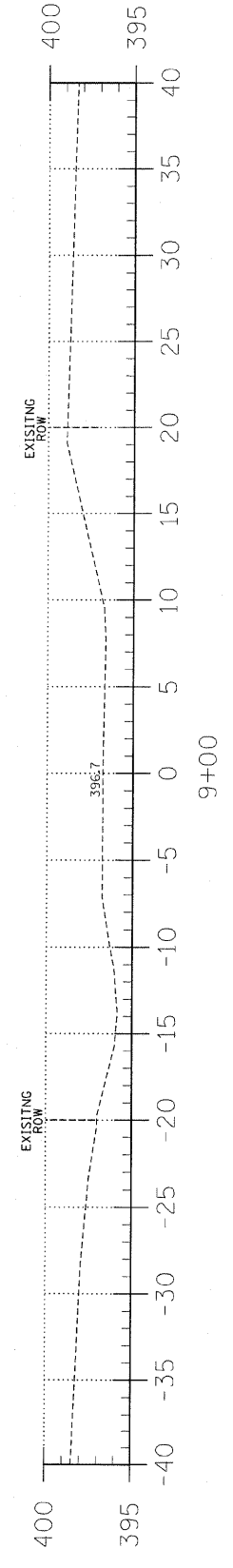
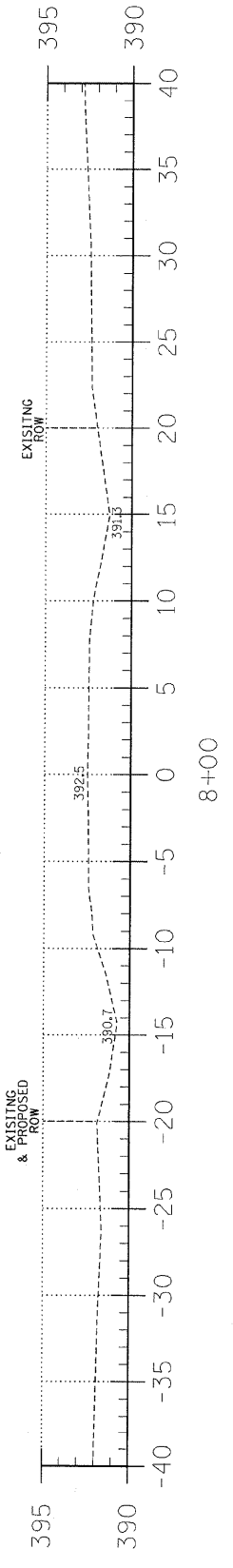
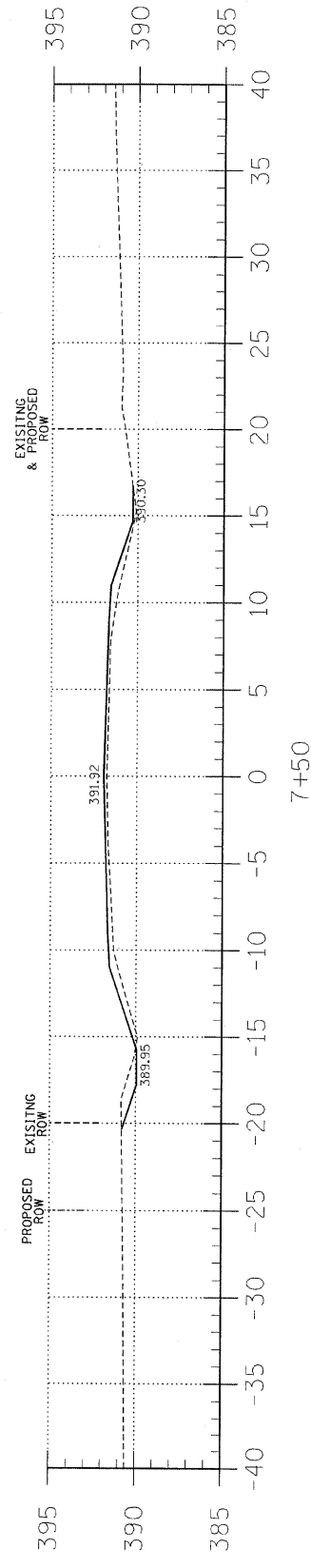
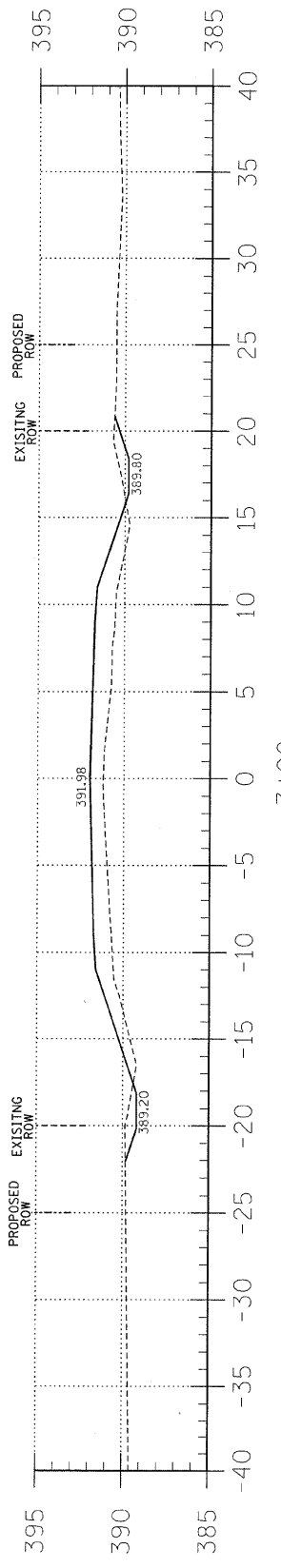
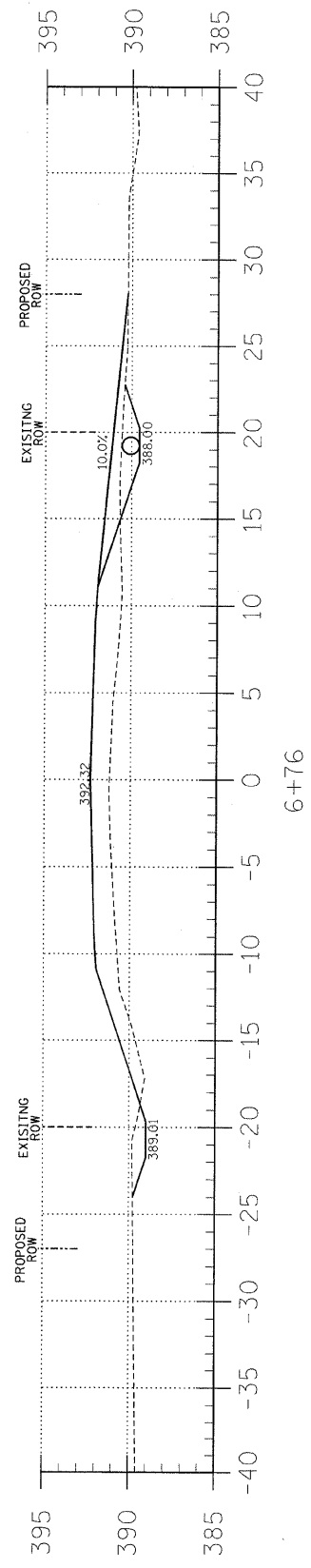
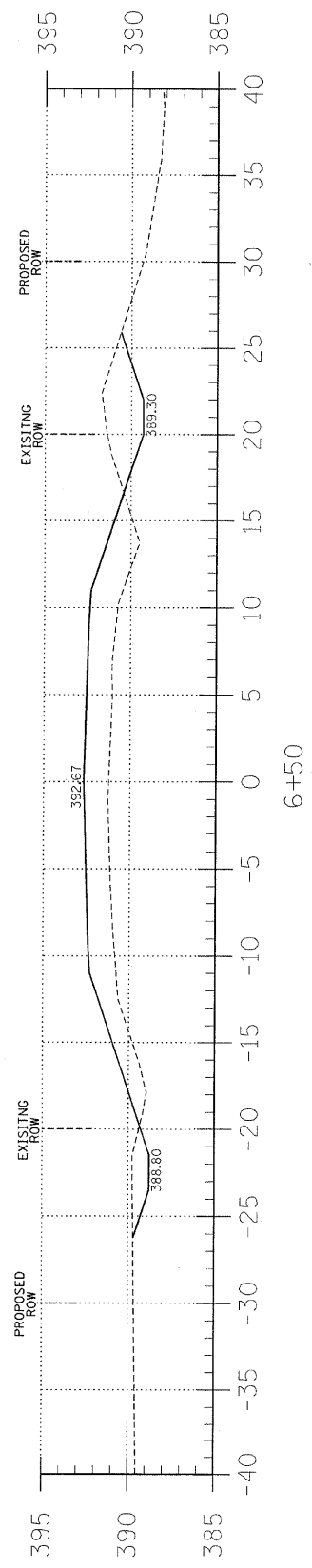
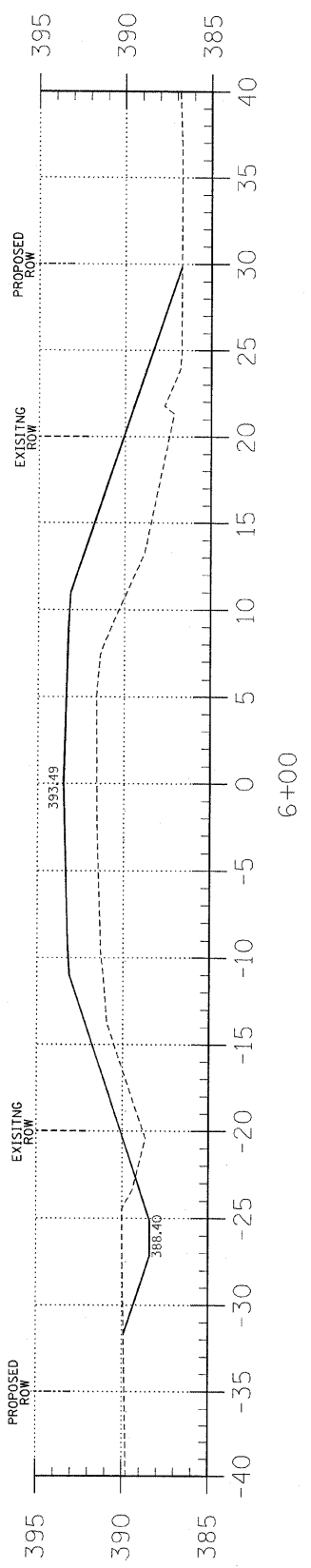
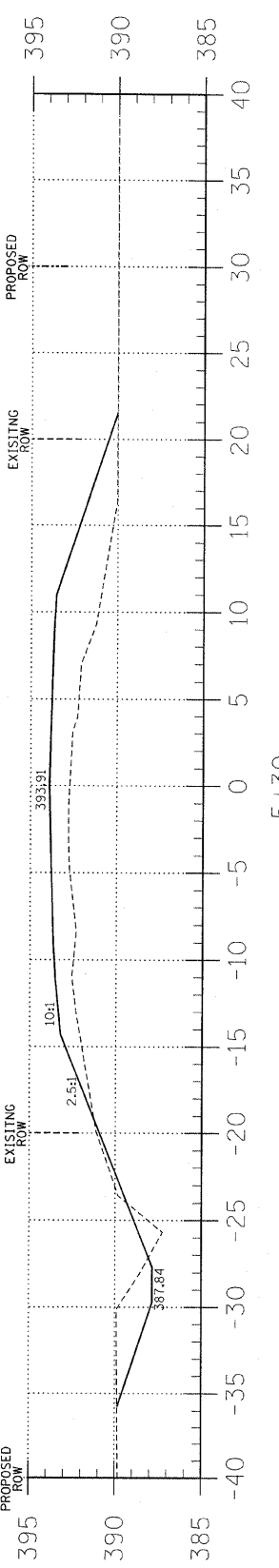

C = 1.7
F = 7.7

C = 3.6
F = 29.3

C = 7.7
F = 36.1

C = 17.9
F = 49.3

C = 11.2
F = 101.0

C = 12.3
F = 52.0

BENCHMARK: Iron Pin, Sta. +4+06.36, 10.23' Rt., Elev. 389.67

EXISTING STRUCTURE: Sta. 5+00 - 2-8' Dia. tank cars; ±24' long
Structure closed to traffic.

No Salvage - Tank cars remain property of Township.

Traffic Barrier Terminal, Type 5A
(NW, SW, & SE corners)
See sheets 4 of 8 for details.

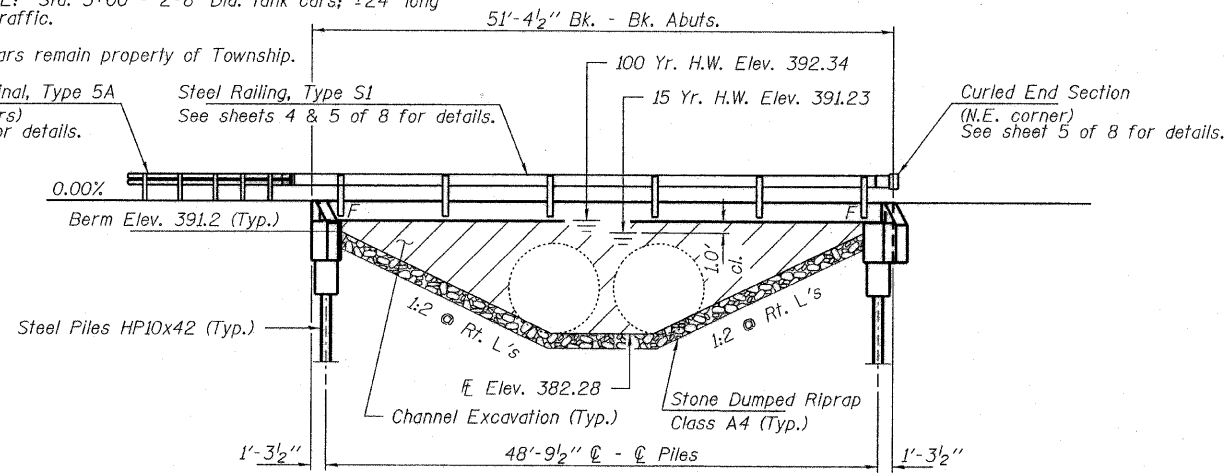

ELEVATION

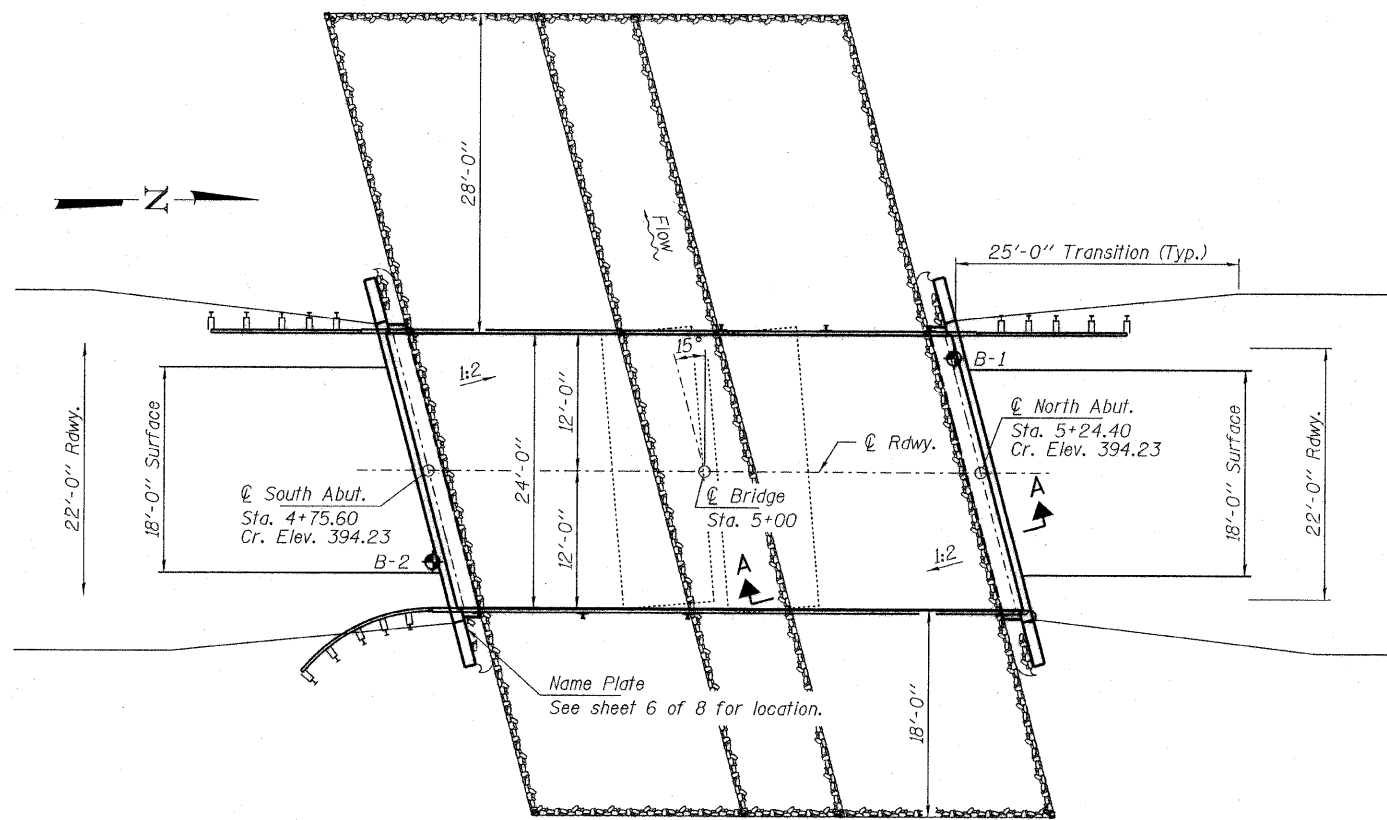

PLAN

GENERAL NOTES

Layout of the slope protection system may be varied to suit ground conditions in the field as directed by the Engineer.
Reinforcement bars shall conform to the requirements of ASTM A 706 Gr 60 (IL Modified). See Special Provisions.
Excavation required to construct the Abutments shall be included in the cost of Concrete Structures. No additional compensation will be allowed for Structure Excavation.
All proposed construction activities shall be in accordance with Nationwide Permit number 14 of the Department of the Army authorized under Section 404 of the Clean Water Act.
The IEPA has issued Section 401 Water Quality Certification for this activity. See Special Provisions for conditions.
See sheet 8 of 8 for Borings.

BUILT 200_ BY
WHITE COUNTY
SEC. 06-08134-00-BR
INDIAN CREEK ROAD DISTRICT
STR. NO. 097-3256
LOADING HL-93

NAME PLATE
See Std. 515001

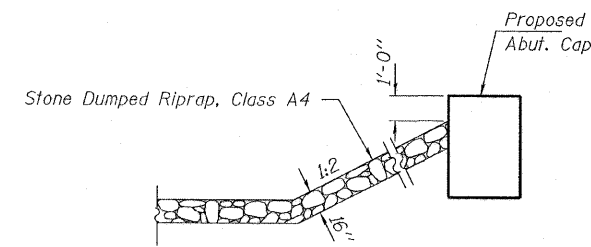

SECTION A-A

Note: See Special Provisions for Stone Dumped Riprap, Class A4.

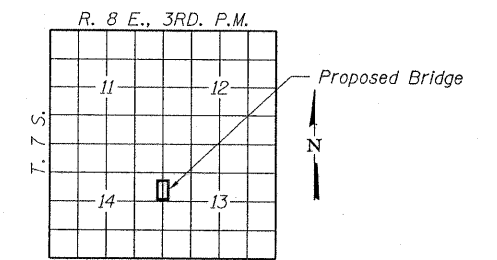

LOCATION SKETCH

TOTAL BILL OF MATERIAL

ITEM	UNIT	SUPER	SUB	TOTAL
Channel Excavation	Cu. Yd.			245
Stone Dumped Riprap, Class A4	Ton			320
Removal of Existing Structures	Each			1
Concrete Structures	Cu. Yd.		23.0	23.0
Concrete Encasement	Cu. Yd.		2.8	2.8
Precast Prestressed Concrete Deck Beams (21" Depth)	Sq. Ft.	1,200		1,200
Reinforcement Bars	Pound		2,500	2,500
Steel Railing, Type S1	Foot	106		106
Furnishing Steel Piles HP10x42	Foot		280	280
Driving Piles	Foot		280	280
Name Plates	Each		1	1

DESIGN STRESSES

FIELD UNITS

f'c = 3,500 psi
fy = 60,000 psi (Reinf.)

PRECAST PRESTRESSED UNITS

f'c = 6,000 psi
f'cl = 5,000 psi
fpu = 270,000 psi (1/2" low lax. strands)
fpbt = 201,960 psi (1/2" low lax. strands)
fy = 60,000 psi (Reinf.)

LOADING HL-93

Design Specifications: 2007 AASHTO LRFD with all applicable Interims.
50#/Sq. Ft. included in dead load for future wearing surface.

DESIGNED - A.S.L.
CHECKED - S.W.M.
DRAWN - D.A.B.
CHECKED - D.T.M.

SEISMIC DATA

Seismic Performance Zone (SPZ) = 3
Design Spectral Acceleration at 1.0 sec. (S_{D1}) = 0.473g
Design Spectral Acceleration at 0.2 sec. (S_{D5}) = 0.877g
Soil Site Class = E

WATERWAY INFORMATION

Drainage Area = 2.5 Sq. Mi.		Existing Low Grade Elev. 389.8 @ Sta. 2+42.5		Proposed Low Grade Elev. 389.8 @ Sta. 2+42.5	
Flood	Freq. Yr.	Q C.F.S.	Opening Sq. Ft. Exist. Prop.	Natural H.W.E. Exist. Prop.	Head - Ft. Exist. Prop.
Design	15	1,174	100 244	391.23 0.11 0.14	391.34 391.37
Base	100	2,050	100 299	392.34 0.0 0.06	392.34 392.40
Max. Calc.					

① Approach opening = 1,019 sq. ft.

I certify that to the best of my knowledge, information and belief, this bridge design is structurally adequate for the design loading shown on the plans. The design is an economical one for the style of structure and complies with requirements of the current "AASHTO LRFD Specifications."

Steven W. Maggioneri
ILLINOIS STRUCTURAL NO. 081-6064

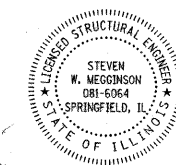

Expires 11-30-10

GENERAL PLAN AND ELEVATION
STRUCTURE NO. 097-3256

HAMPTON, LENZINI & RENWICK, INC. CIVIL & STRUCTURAL ENGINEERS LAND SURVEYORS 3085 STEVENSON DRIVE, SUITE 201 SPRINGFIELD, ILLINOIS 62703 (217) 546-3400	SHEET NO. 1 8 SHEETS	T.R.	SECTION	COUNTY	TOTAL SHEETS	SHEET NO.
		128	06-08134-00-BR	WHITE	12	5
		INDIAN CREEK ROAD DISTRICT		CONTRACT NO. 99373		
PROJECT NUMBER: 08.0280.130	DATE: 10/15/09	FED. ROAD DIST. NO.		ILLINOIS FED. AID PROJECT BROS-193(30)		

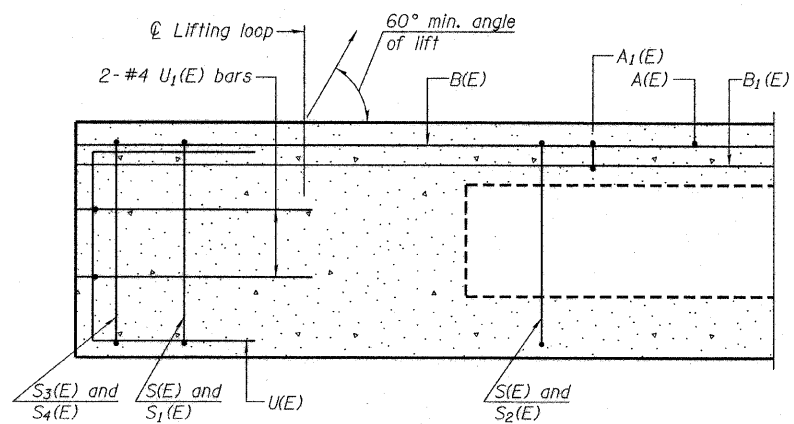

SECTION C-C

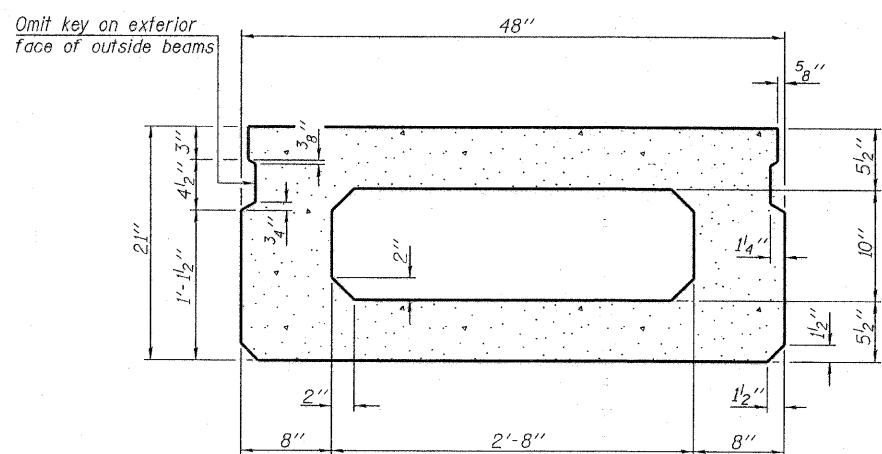

SECTION A-A
(Showing dimensions)

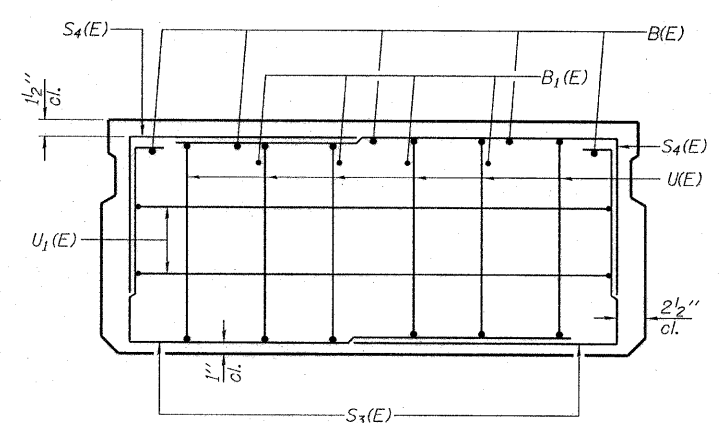

VIEW B-B

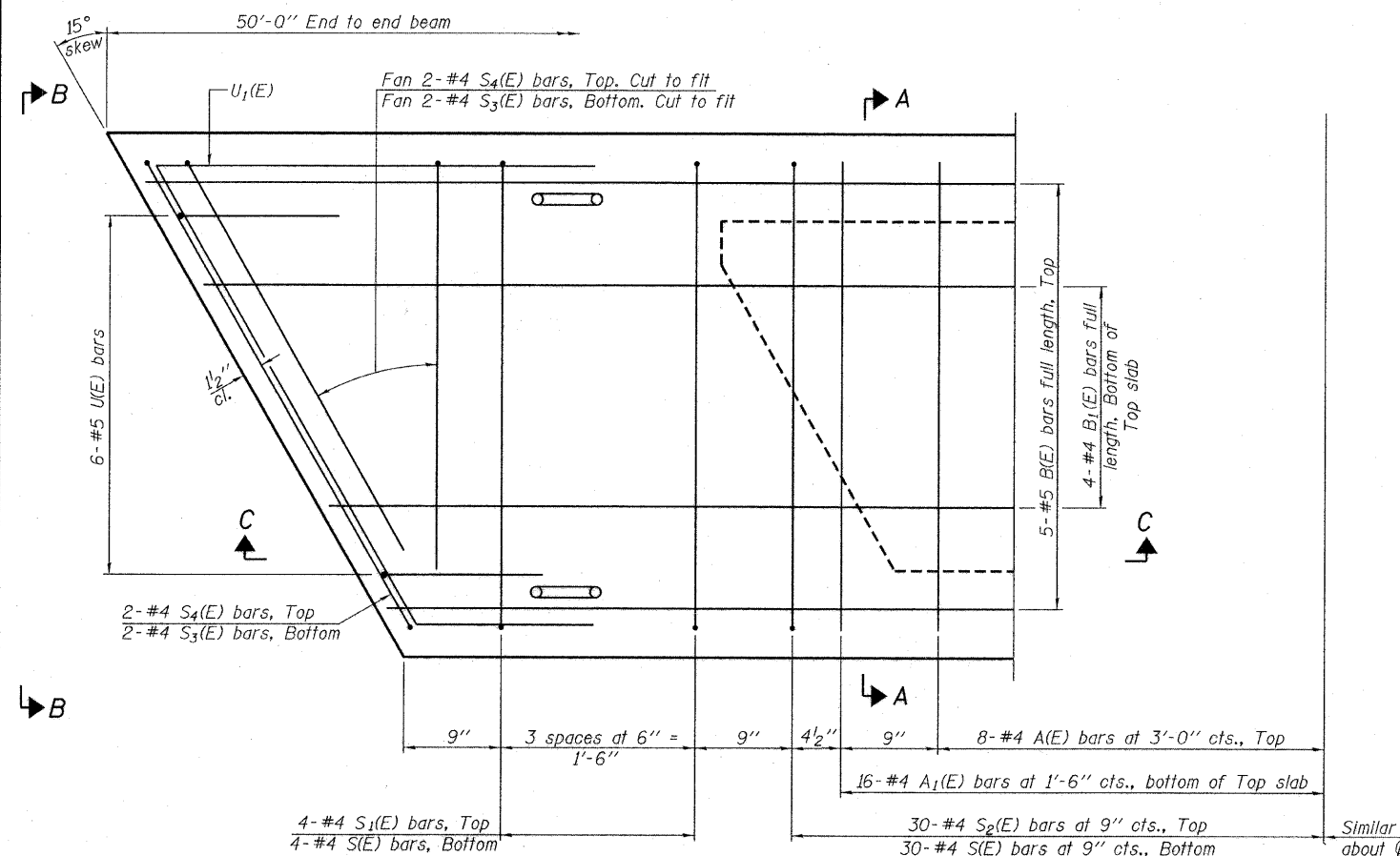

PLAN VIEW

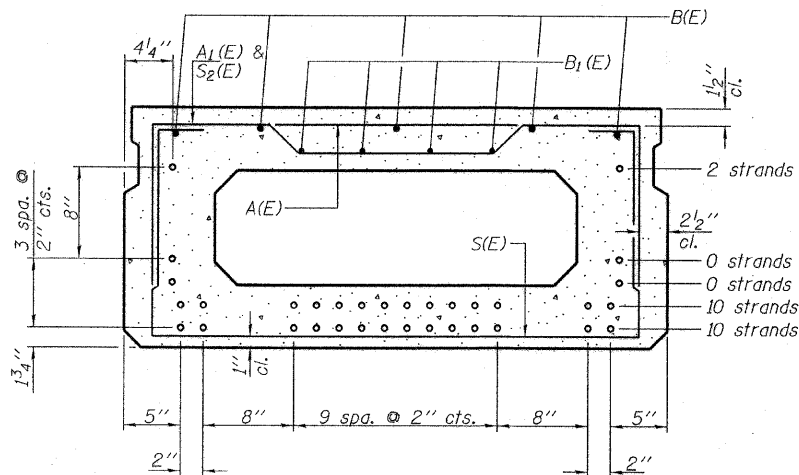

SECTION A-A

(Showing reinforcement and permissible strand locations)
 Note: Place the number of strands specified in each row symmetrically about the centerline of beam in the permissible strand locations shown.

BAR LIST
ONE BEAM ONLY
 (For information only)

Bar	No.	Size	Length	Shape
A(E)	16	#4	3'-7"	—
A1(E)	32	#4	3'-10"	—
B(E)	5	#5	49'-8"	—
B1(E)	4	#4	49'-8"	—
S(E)	68	#4	7'-5"	U
S1(E)	8	#4	5'-11"	U
S2(E)	60	#4	6'-2"	U
S3(E)	8	#4	4'-8"	J
S4(E)	8	#4	3'-11"	J
UK(E)	12	#5	4'-0"	C
U1(E)	4	#4	7'-1"	C

Note: See sheets 3 & 4 of 8 for additional details and Bill of Material.

Note: Spacing of S(E) and S2(E) bars may be adjusted up to 4" in the immediate area of the transverse tie diaphragms to miss the block outs for the transverse ties.

DESIGNED - A.S.L.
CHECKED - S.W.M.
DRAWN - D.A.B.
CHECKED - D.T.M.

PD-2148-R 10-1-08

HAMPTON, LENZINI & RENWICK, INC. CIVIL & STRUCTURAL ENGINEERS LAND SURVEYORS HLR 3085 STEVENSON DRIVE, SUITE 201 SPRINGFIELD, ILLINOIS 62703 (217) 548-3400 PROJECT NUMBER: 08.0260.130 DATE: 10/15/08	SHEET NO. 2 8 SHEETS	T.R.	SECTION	COUNTY	TOTAL SHEETS	SHEET NO.
		128	06-08134-00-BR	WHITE	12	6
		INDIAN CREEK ROAD DISTRICT		CONTRACT NO. 99373		
		FED. ROAD DIST. NO.	ILLINOIS FED. AID PROJECT BROS-193(30)			

SUPERSTRUCTURE
21" X 48" PPC DECK BEAM
STRUCTURE NO. 097-3256

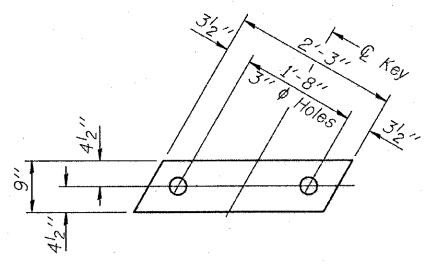

FABRIC BEARING PAD
(Interior - 10 Req'd.)

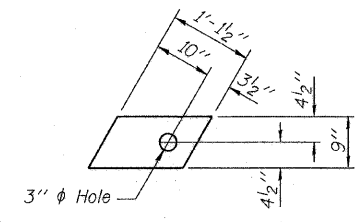

FABRIC BEARING PAD
(Exterior - 4 Req'd.)

FIXED

Note: Omit holes when using expansion bearings.

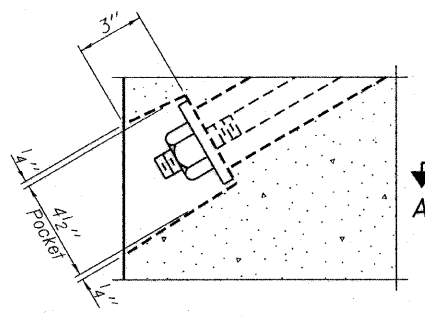

SECTION A-A

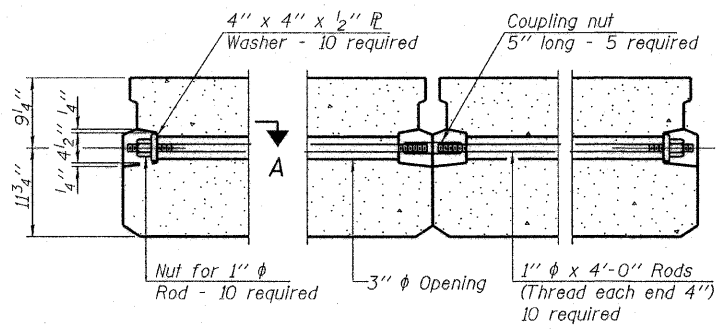

TYPICAL TRANSVERSE TIE ASSEMBLY

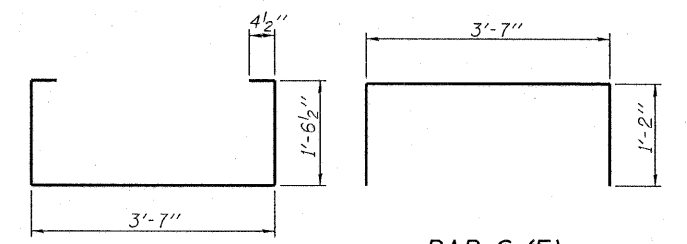

BAR S₁(E)

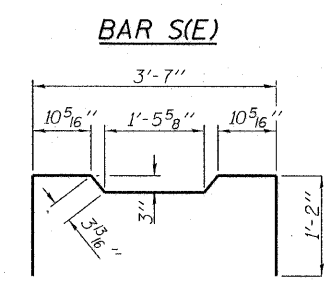

BAR S₂(E)

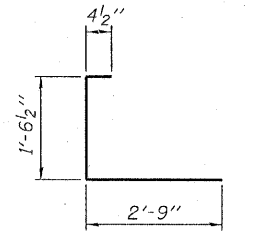

BAR S₃(E)

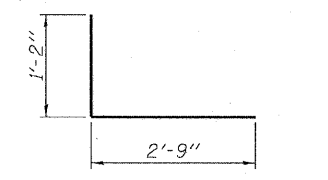

BAR S₄(E)

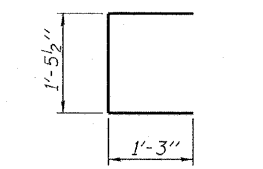

BAR UE

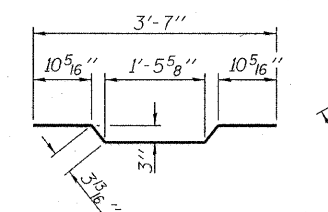

BAR A₁(E)

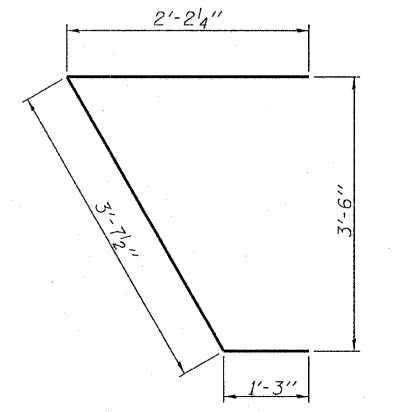

BAR U₁(E)

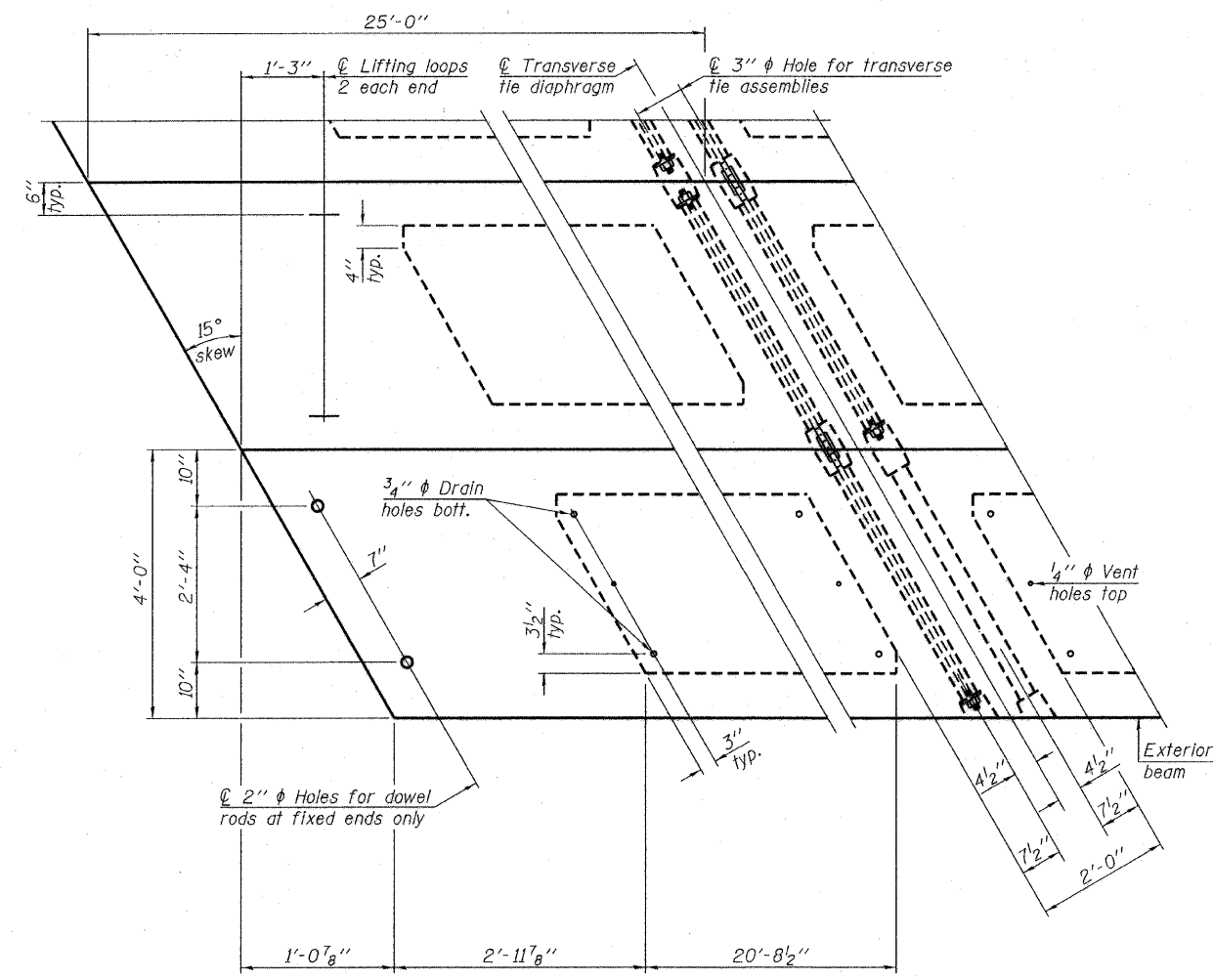

PLAN VIEW

NOTES

Prestressing steel shall be uncoated high strength, low relaxation 7-wire strand, Grade 270. The nominal diameter shall be 1/2" and the nominal cross-sectional area shall be 0.153 sq. in. The 1" rods in the transverse tie assembly shall be tightened to a snug fit and the threads set. Pockets on exterior faces of bridge shall be filled with grout after transverse tie assembly is in place. Reinforcement bars shall conform to ASTM A 706, Grade 60. (See Special Provisions). Two 1/8" fabric adjusting shims of the dimensions of the exterior bearing pad shall be provided for each bearing pad location. A minimum 2 1/2" lifting pin shall be used to engage the lifting loops during handling. Corrosion Inhibitor, per Article 1020.05(b)(12) and 1021.06 of the Standard Specifications, shall be used in the concrete for precast prestressed concrete deck beams. Compressive strength of prestressed concrete, f'_c, shall be 6000 psi. Compressive strength of prestressed concrete at release, f'_{cl}, shall be 5000 psi.

Note: Connect beams in pairs with the transverse tie configuration shown.

DESIGNED - A.S.L.
CHECKED - S.W.M.
DRAWN - D.A.B.
CHECKED - D.T.M.

PD-2148-RD 10-1-08

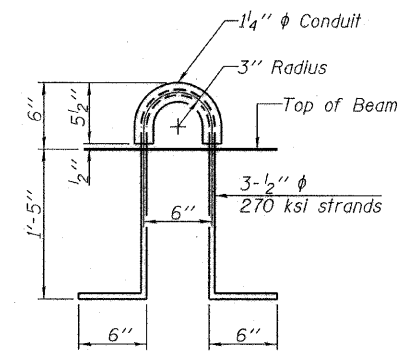

LIFTING LOOP DETAIL

BILL OF MATERIAL

Precast Prestressed Conc. Deck Bms. (21" depth)	Sq. Ft.	1,200
---	---------	-------

SUPERSTRUCTURE DETAILS
21" X 48" PPC DECK BEAM
STRUCTURE NO. 097-3256

HAMPTON, LENZINI & RENWICK, INC. CIVIL & STRUCTURAL ENGINEERS LAND SURVEYORS 3085 STEVENSON DRIVE, SUITE 201 SPRINGFIELD, ILLINOIS 62703 (217) 546-3400	SHEET NO. 3 8 SHEETS	T.R.	SECTION	COUNTY	TOTAL SHEETS	SHEET NO.
		128	06-08134-00-BR	WHITE	12	7
PROJECT NUMBER: 08.0260.130 DATE: 10/15/09		INDIAN CREEK ROAD DISTRICT		CONTRACT NO. 99373		
		FED. ROAD DIST. NO.	ILLINOIS	FED. AID PROJECT BROS-193(30)		

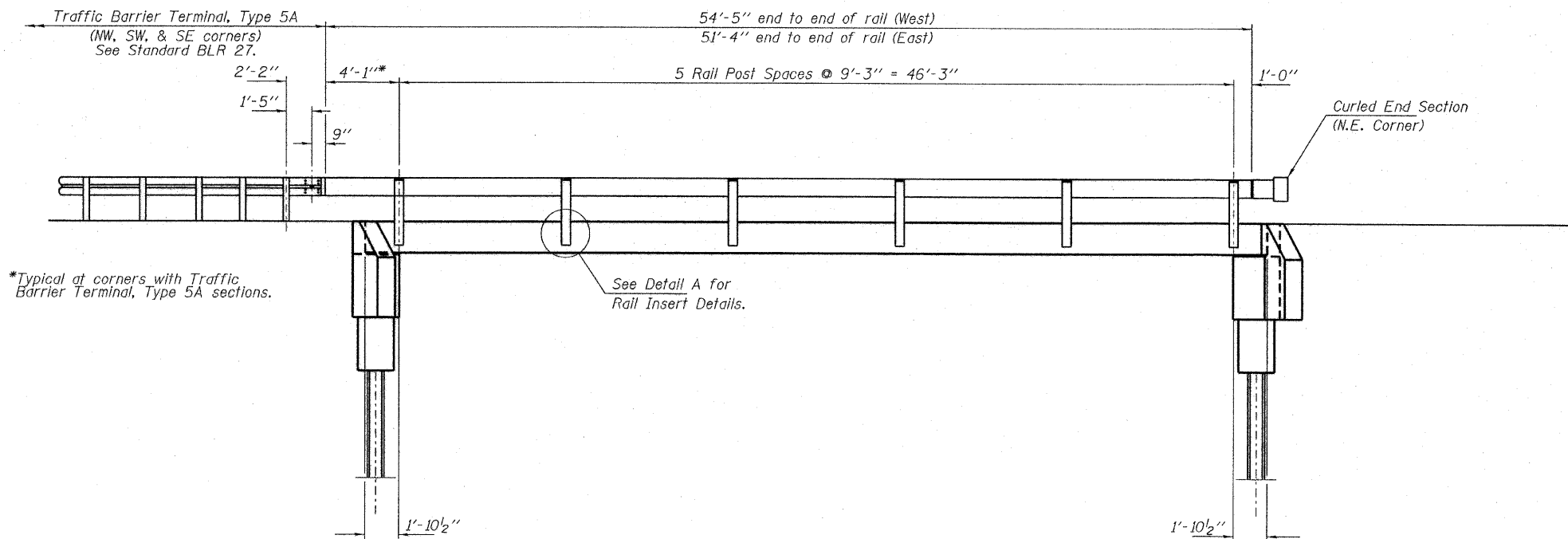

*Typical at corners with Traffic Barrier Terminal, Type 5A sections.

See Detail A for Rail Insert Details.

ELEVATION

Showing Rail Post Spaces

See sheet 5 of 8 for Railing Details.

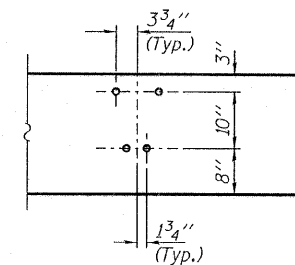

DETAIL A

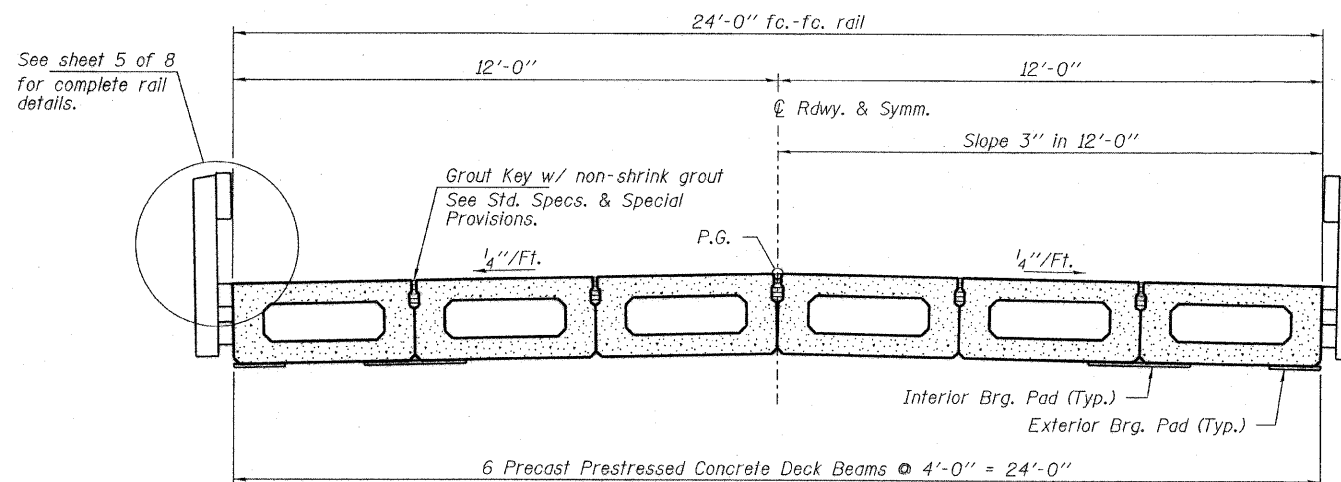

CROSS SECTION

See sheets 2 & 3 of 8 for Superstructure.

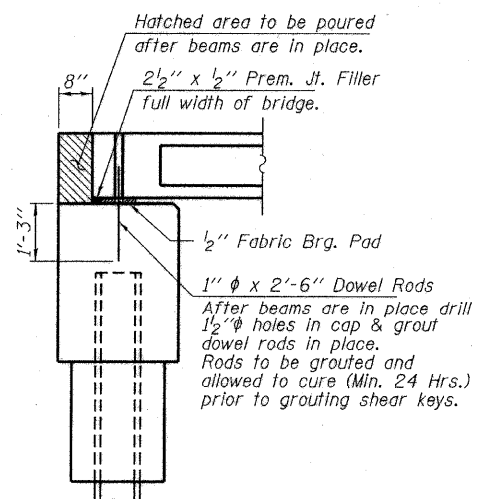

SECTION AT ABUTMENTS

© Rt. L's

DESIGNED - A.S.L.
CHECKED - S.W.M.
DRAWN - D.A.B.
CHECKED - D.T.M.

**SUPERSTRUCTURE DETAILS
STRUCTURE NO. 097-3256**

HAMPTON, LENZINI & RENWICK, INC. CIVIL & STRUCTURAL ENGINEERS LAND SURVEYORS HLR 3085 STEVENSON DRIVE, SUITE 201 SPRINGFIELD, ILLINOIS 62703 (217) 546-3400 PROJECT NUMBER: 08.0260.130 DATE: 10/15/09	SHEET NO. 4	T.R.	SECTION	COUNTY	TOTAL SHEETS	SHEET NO.
	8 SHEETS	128	06-08134-00-BR	WHITE	12	8
		INDIAN CREEK ROAD DISTRICT		CONTRACT NO. 99373		
	FED. ROAD DIST. NO.		ILLINOIS	FED. AID PROJECT BROS-193(30)		

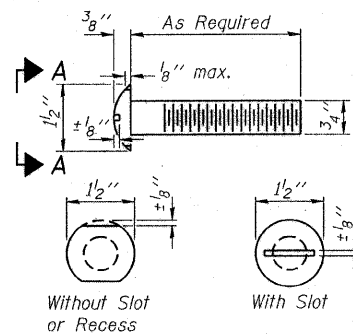

**VIEW A-A
ROUND HEAD BOLT**

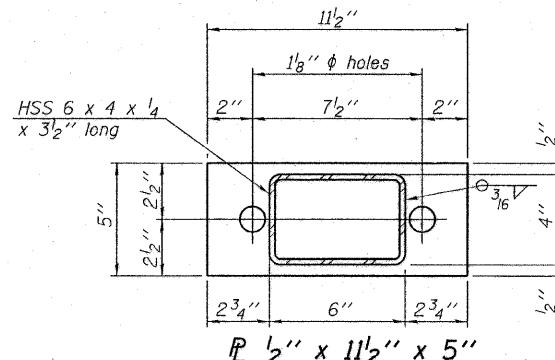

SECTION B-B

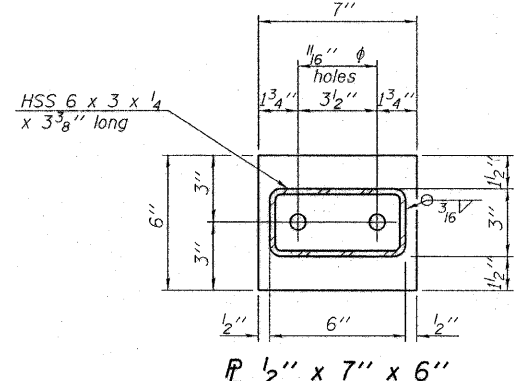

SECTION AT RAILING POST

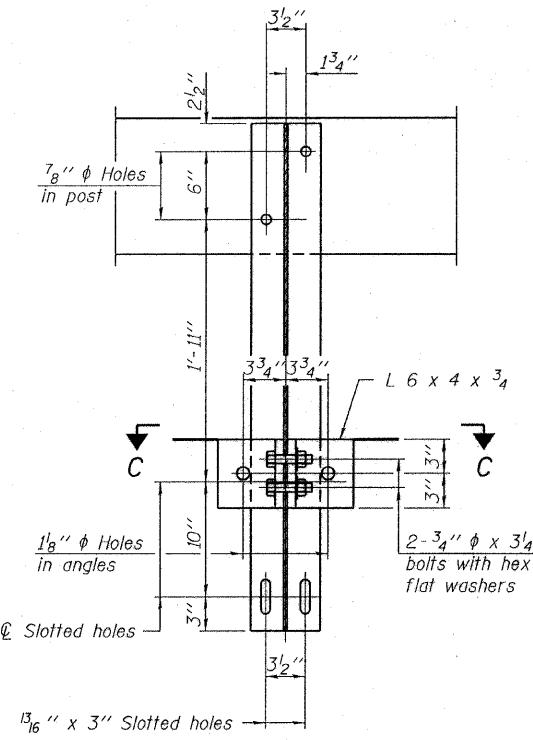

SECTION C-C

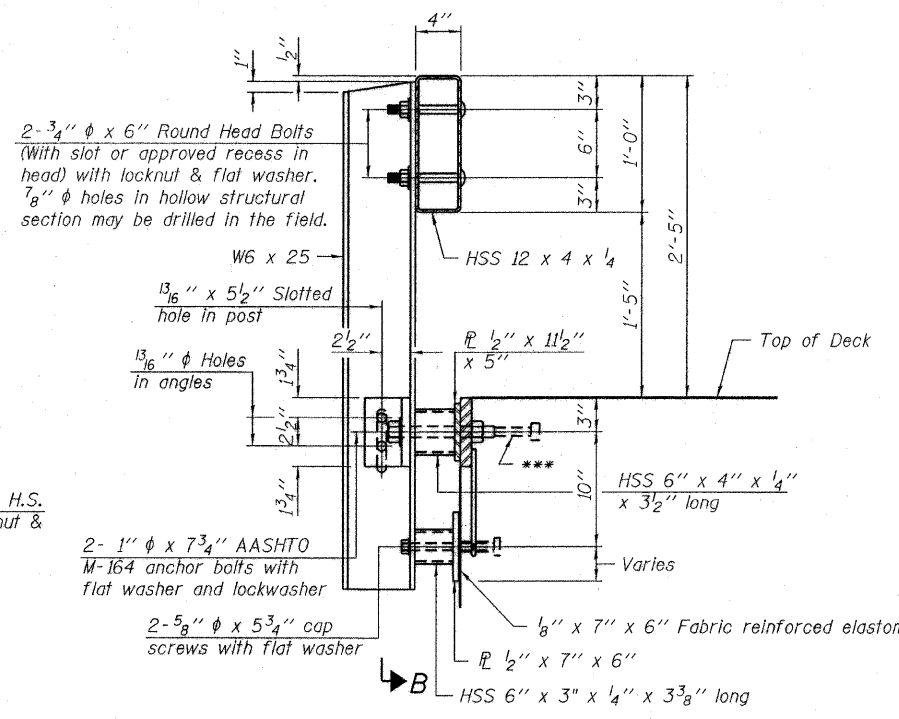

SECTION AT RAILING POST

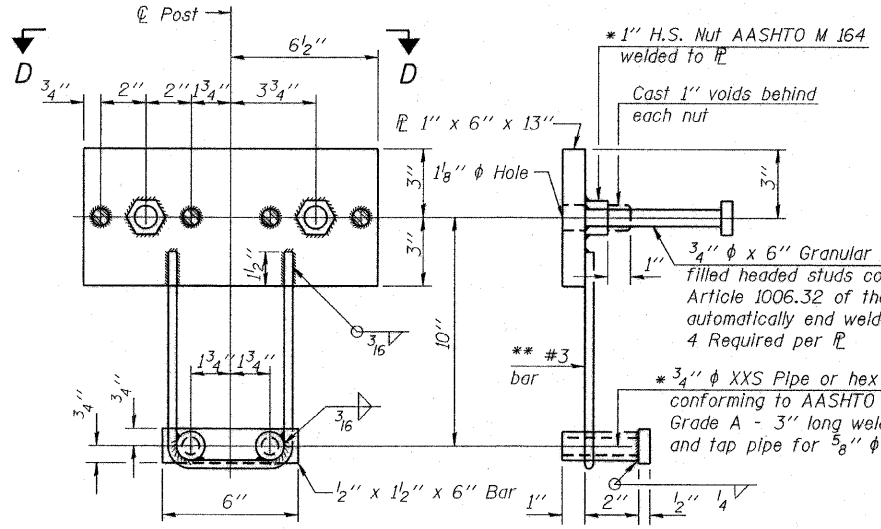

ANCHOR DEVICE

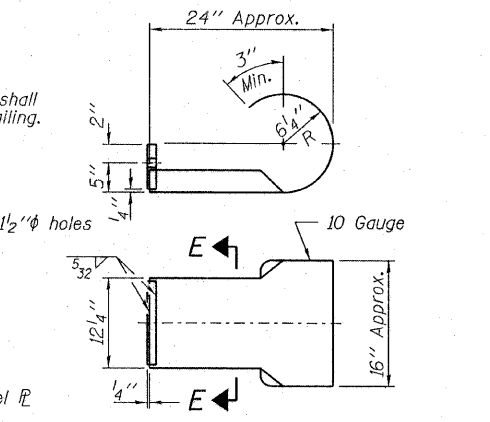

SECTION E-E CURLED END SECTION DETAILS

Note: Cost of curled end sections shall be included with the Steel Railing. (1 Required)

Notes:
All field drilled holes shall be coated with an approved zinc rich paint before erection.
For multi-span bridges, sufficient 1/4 inch x 6 inch x 1-2 inch galvanized steel shims shall be provided to align rail between adjacent spans. Cost included with Steel Railing, Type S-1.
All steel rail elements shall be galvanized according to Article 509.05 of the Standard Specifications.
*** The studs of the anchor devices shall be placed below the top reinforcement bars and the outermost longitudinal reinforcement bar shall be placed directly above the studs of the rail post anchor device.

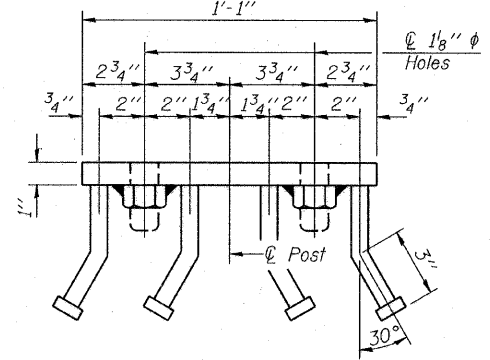

VIEW D-D

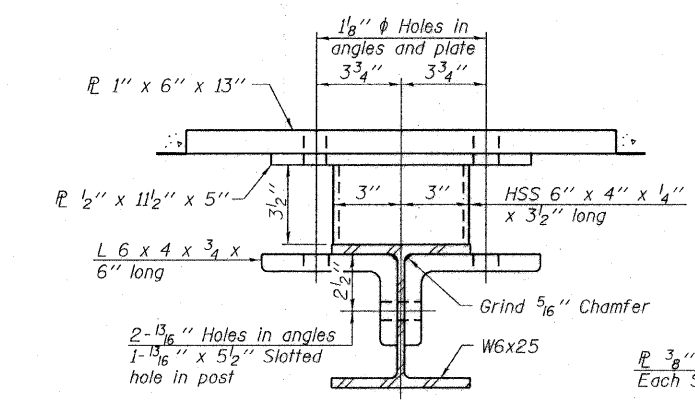

SECTION C-C

** Whenever the lower insert assemblies interfere with strand locations, the #3 bars shall be cut and adjusted in order to allow raising or lowering of the lower inserts. Maximum adjustment not to exceed 1/2 inch.

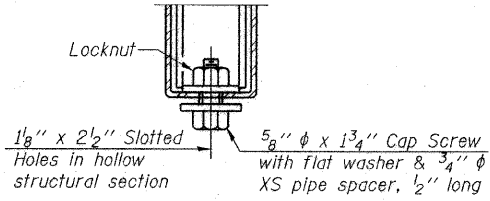

RAIL SPLICE CONNECTION AT EXPANSION JT.

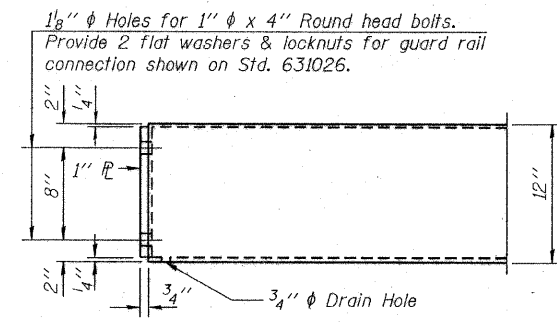

END OF RAIL DETAILS

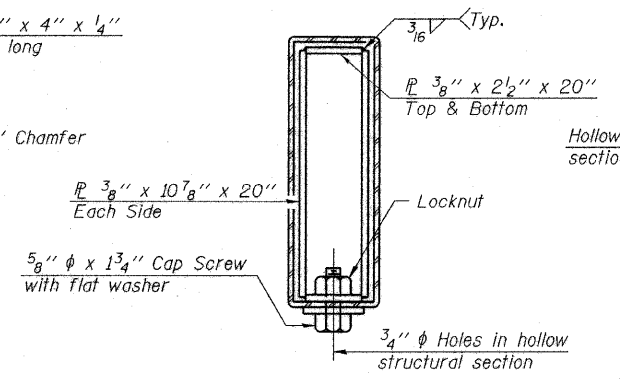

SECTIONS AT RAIL SPLICE

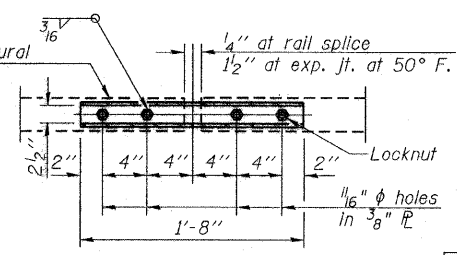

PLAN-BOTT. SPLICE R TYPICAL

BILL OF MATERIAL

Item	Unit	Quantity
Steel Railing, Type S-1	Foot	106

**STEEL RAILING, TYPE S-1
STRUCTURE NO. 097-3256**

DESIGNED - A.S.L.
CHECKED - S.W.M.
DRAWN - D.A.B.
CHECKED - D.T.M.

R-23A

10-1-08 (10'-9" Maximum Post Spacing)

HAMPTON, LENZINI & RENWICK, INC.
CIVIL & STRUCTURAL ENGINEERS
LAND SURVEYORS
HLR
3085 STEVENSON DRIVE, SUITE 201
SPRINGFIELD, ILLINOIS 62703
(217) 546-3400
PROJECT NUMBER: 08.0260.130 DATE: 10/15/09

SHEET NO. 5 8 SHEETS	T.R.	SECTION	COUNTY	TOTAL SHEETS	SHEET NO.
	128	06-08134-00-BR	WHITE	12	9
INDIAN CREEK ROAD DISTRICT			CONTRACT NO. 99373		
FED. ROAD DIST. NO.		ILLINOIS	FED. AID PROJECT BROS-193(30)		

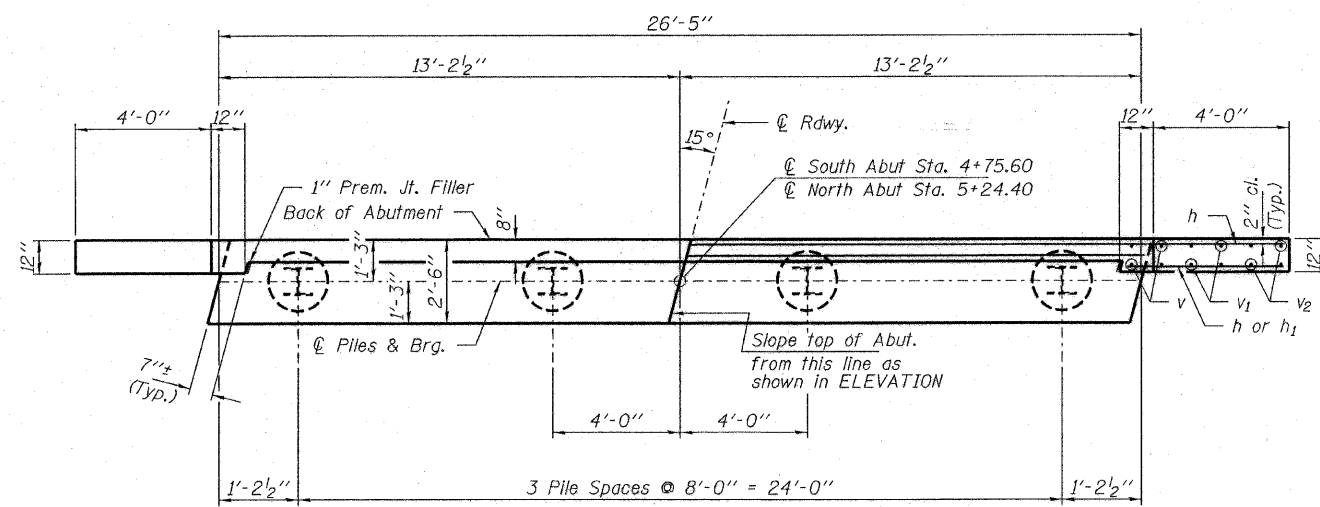

PLAN

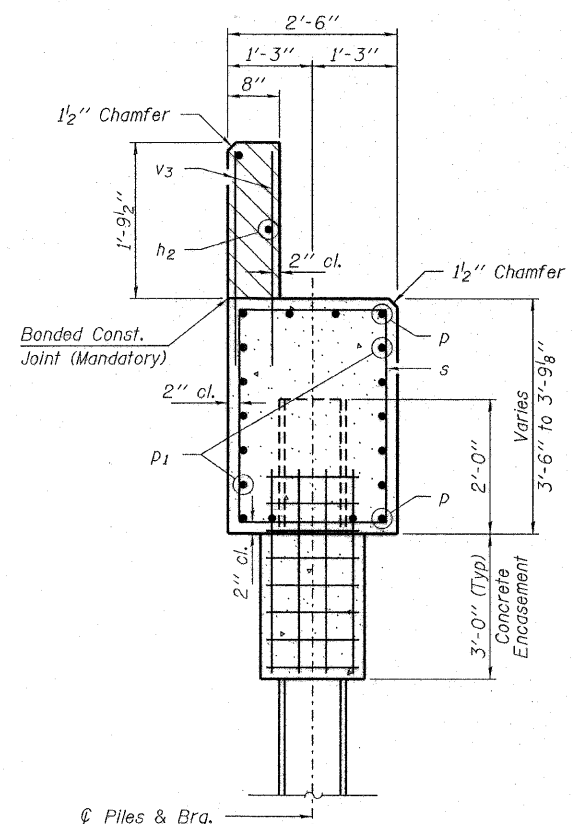

SECTION A-A

Hatched area to be poured after beams are in place.

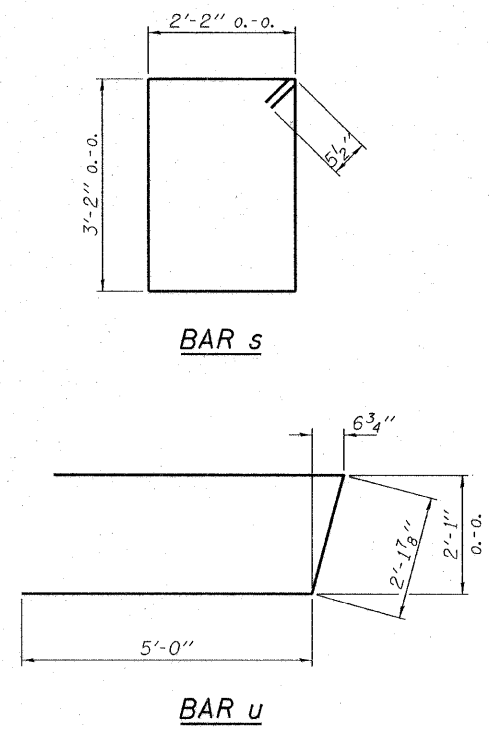

BAR s

BAR u

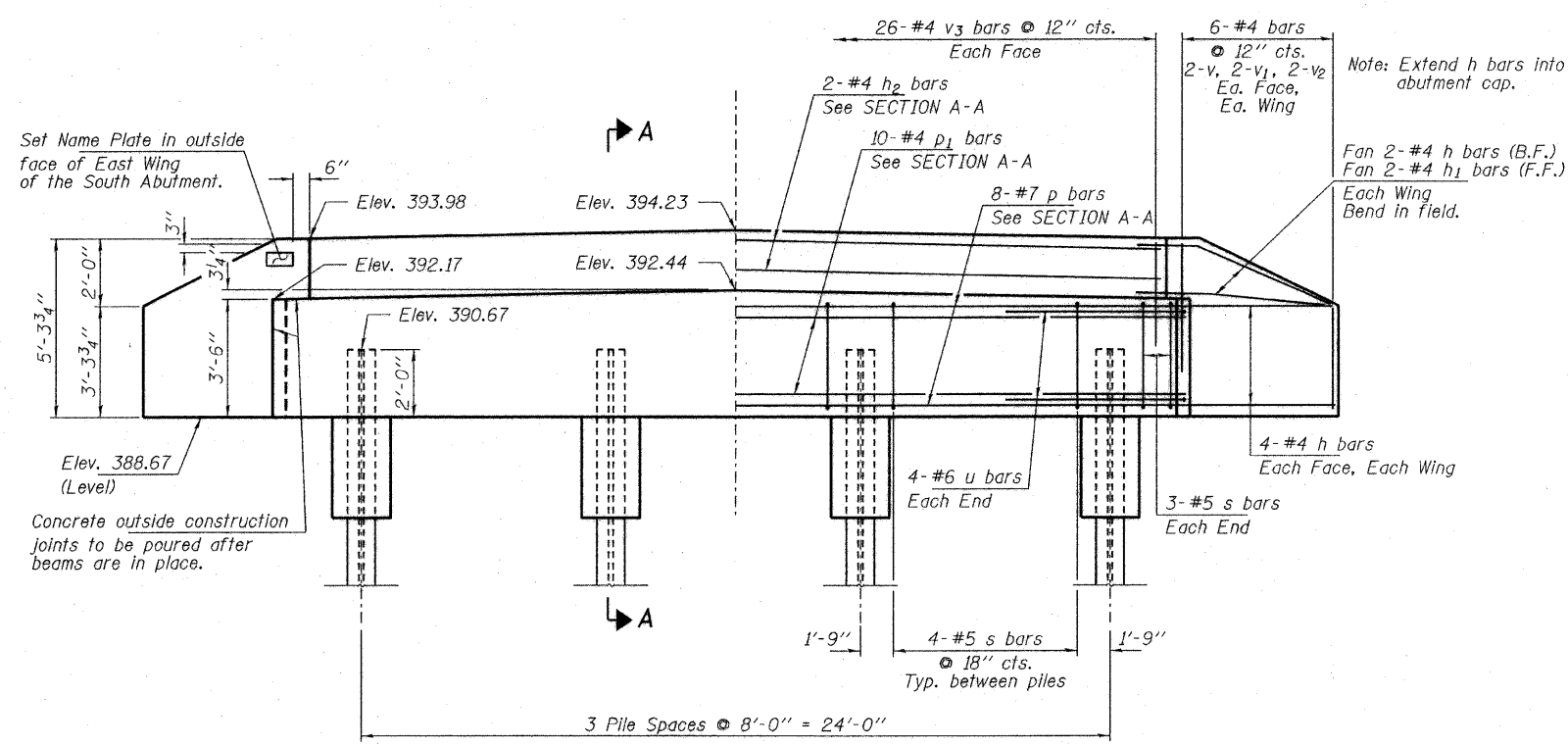

ELEVATION

PILE DATA

Type: Steel HP10x42
 No. Req'd. (2 Abutments): 8
 Factored Resistance Available (Rf): 167 Kips/Pile
 Nominal Required Bearing (Rn): 335 Kips/Pile
 Est. Length: 35 Ft/Pile

Note: The Steel H-Piles shall be according to AASHTO M270 Grade 50.

BILL OF MATERIAL - 2 ABUTS.

BAR	NO.	SIZE	LENGTH	SHAPE
h	40	#4	6'-3"	—
h ₁	8	#4	4'-9"	—
h ₂	4	#4	26'-1"	—
p	16	#7	26'-1"	—
p ₁	20	#4	26'-1"	—
s	36	#5	11'-7"	□
u	16	#6	12'-2"	—
v	16	#4	4'-11"	—
v ₁	16	#4	3'-11"	—
v ₂	16	#4	2'-11"	—
v ₃	104	#4	2'-8"	—
Concrete Structures			Cu. Yd.	23.0
Concrete Encasement			Cu. Yd.	2.8
Reinforcement Bars			Pound	2,500
Steel Piles HP10x42			Foot	280
Name Plates			Each	1

DESIGNED - A.S.L.
CHECKED - S.W.M.
DRAWN - D.A.B.
CHECKED - D.T.M.

ABUTMENTS
 STRUCTURE NO. 097-3256

HAMPTON, LENZINI & RENWICK, INC. CIVIL & STRUCTURAL ENGINEERS LAND SURVEYORS HLR 3085 STEVENSON DRIVE, SUITE 201 SPRINGFIELD, ILLINOIS 62703 (217) 546-3400	SHEET NO. 6	T.R.	SECTION	COUNTY	TOTAL SHEETS	SHEET NO.
	8 SHEETS	128	06-08134-00-BR	WHITE	12	10
	PROJECT NUMBER: 08.0260.130	DATE: 10/15/09	INDIAN CREEK ROAD DISTRICT		CONTRACT NO. 99373	
		FED. ROAD DIST. NO.	ILLINOIS	FED. AID PROJECT BROS-193(30)		

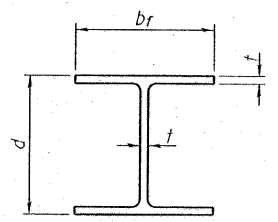

STEEL PILE TABLE

Designation	Depth d	Flange width br	Web and Flange thickness t	Encasement diameter A
HP 14x117	14 1/4"	14 7/8"	13/16"	30"
x102	14"	14 3/4"	11/16"	30"
x89	13 7/8"	14 3/4"	5/8"	30"
x73	13 5/8"	14 5/8"	1/2"	30"
HP 12x84	12 1/4"	12 1/4"	11/16"	24"
x74	12 1/8"	12 1/4"	5/8"	24"
x63	12"	12 1/8"	1/2"	24"
x53	11 3/4"	12"	7/16"	24"
HP 10x57	10"	10 1/4"	9/16"	24"
x42	9 3/4"	10 1/8"	7/16"	24"
HP 8x36	8"	8 1/8"	7/16"	18"

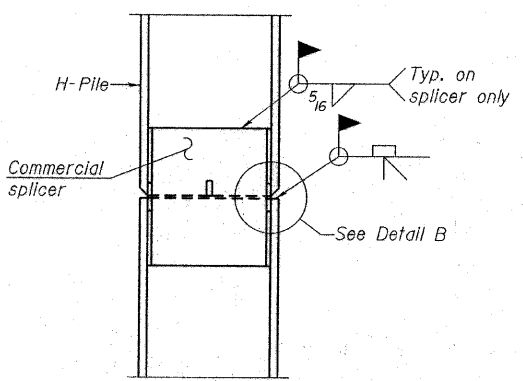

ELEVATION

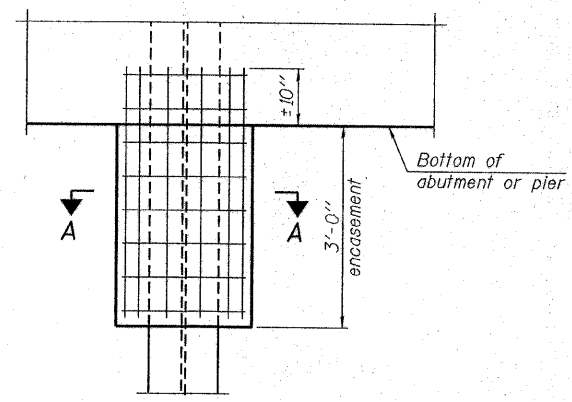

ELEVATION

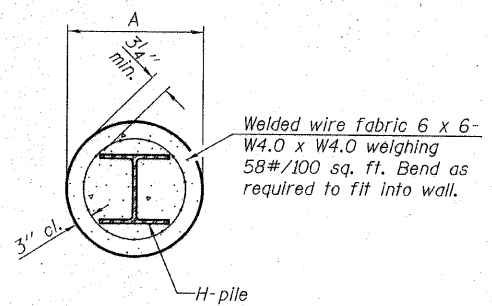

SECTION A-A

PILE ENCASEMENT

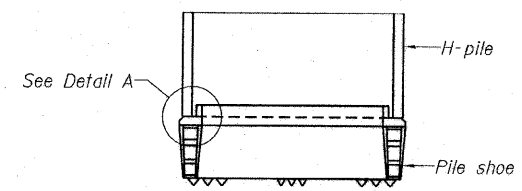

ELEVATION

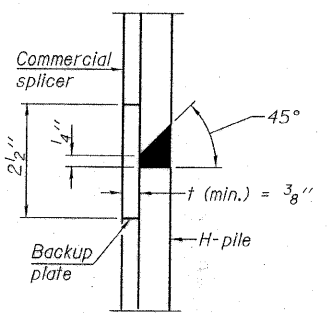

DETAIL "B"

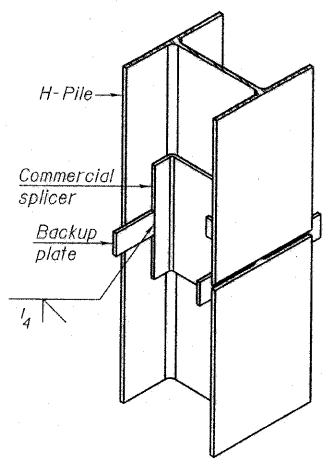

ISOMETRIC VIEW

WELDED COMMERCIAL SPLICE

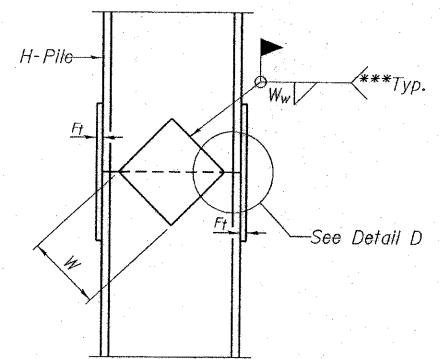

ELEVATION

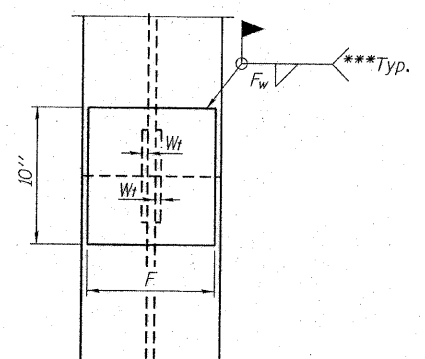

END VIEW

Designation	F	F _t	F _w	W	W _t	W _w
HP 14x117	12 1/2"	1"	7/8"	7 3/4"	5 1/2"	1/2"
x102	12 1/2"	7/8"	3/4"	7 3/4"	5 1/2"	1/2"
x89	12 1/2"	3/4"	1/2"	7 3/4"	5 1/2"	1/2"
x73	12 1/2"	5/8"	9/16"	7 3/4"	5 1/2"	1/2"
HP 12x84	10"	7/8"	1/2"	6 1/2"	5 1/2"	1/2"
x74	10"	7/8"	1/2"	6 1/2"	5 1/2"	1/2"
x63	10"	5/8"	1/2"	6 1/2"	1/2"	3/8"
x53	10"	5/8"	1/2"	6 1/2"	1/2"	3/8"
HP 10x57	8"	3/4"	9/16"	5 1/4"	1/2"	3/8"
x42	8"	5/8"	9/16"	5 1/4"	1/2"	3/8"
HP 8x36	7"	5/8"	7/16"	4 1/4"	1/2"	3/8"

WELDED PLATE FIELD SPLICE

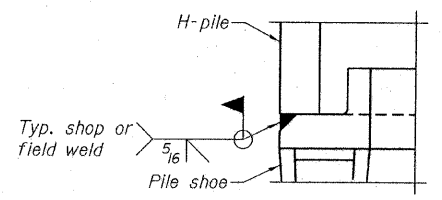

DETAIL A

H-PILE SHOE ATTACHMENT

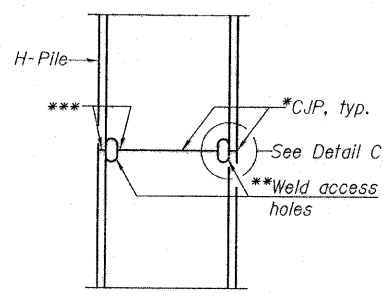

ELEVATION

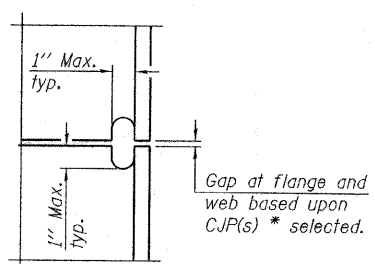

DETAIL C

COMPLETE PENETRATION WELD SPLICE

- * Use joint conforming to Figure 3.4 in AWS D1.1, Structure Welding Code - Steel.
- ** Preparation per Fig. 5.2 in AWS D1.1, Structure Welding Code - Steel.
- *** Interrupt welds 1/4" from end of each pile.

Note:
The steel H-piles shall be according to AASHTO M270 Grade 50.

DESIGNED - A.S.L.
CHECKED - S.W.M.
DRAWN - D.A.B.
CHECKED - D.T.M.

F-HP 10-1-08

**HP PILE DETAILS
STRUCTURE NO. 097-3256**

HLR HAMPTON, LENZINI & RENWICK, INC. CIVIL & STRUCTURAL ENGINEERS LAND SURVEYORS 3085 STEVENSON DRIVE, SUITE 201 SPRINGFIELD, ILLINOIS 62703 (217) 546-3400 PROJECT NUMBER: 08 0260.130 DATE: 10/15/09	SHEET NO. 7	T.R.	SECTION	COUNTY	TOTAL SHEETS	SHEET NO.
	8 SHEETS	128	06-08134-00-BR	WHITE	12	11
			INDIAN CREEK ROAD DISTRICT	CONTRACT NO. 99373		
			FED. ROAD DIST. NO.	ILLINOIS FED. AID PROJECT BROS-193(30)		

HOLCOMB FOUNDATION ENGINEERING INC.
P.O. Box 88 618-529-5262
Carbondale, Il. 62903 618-457-8991 fax Page 1 of 1

Bridge Foundation Boring Log

Project: H-08083 Bridge _____ Date: 5-6-08
Section: 06-08134-00-BR Station _____
Structure: 097-3064 Bored by: D. Russell
County: White Checked By: T. Holcomb

Boring No:	Elevation	N	Qu tsf	w %	Surface Water Elev.	Elevation	N	Qu tsf	w %
1									
Station:					Ground Water Elev. 363.54				
Offset:					During Drilling 70.9				
					Upon Completion 377.54				
					84.9				
Ground Surface 392.54-00.9	0				silty clay (continued)				
3" Crushed Stone 392.34-00.7									
Brown Sandy CLAY (A-6)		3	0.9S	15	368.54-76.9		4	1.4B	26
					366.04-73.4				
		3	0.9S	23			5	1.2B	22
Brown Mottled Gray Sandy CLAY (A-6)		1	0.2B	29			5	1.4B	22
Gray Mottled Brown Sandy CLAY (A-6)		4	0.8S	20	360.54-67.9				
		4	0.9B	23					
		5	1.2S	29					
Gray Mottled Brown Silty CLAY to CLAY (A-6)		6	2.0S	26	353.54-60.9				
		5	1.4B	29					
Gray Mott. Brown Silty CLAY(A-6)		4	1.1B	27					

N = Standard Penetration Test Blows per foot to drive 2" O.D. Split Spoon Sampler 12" with a 140 lbs. hammer falling 30"
Qu - Unconfined Compressive Strength in tons/sq.ft.
w - Water Content - percentage of oven dry weight-%
B = Bulge Failure
S = Shear Failure
E = Estimated Value
P = Penetrometer

BORING 1

DESIGNED - A.S.L.
CHECKED - S.W.M.
DRAWN - D.A.B.
CHECKED - D.T.M.

HOLCOMB FOUNDATION ENGINEERING INC.
P.O. Box 88 618-529-5262
Carbondale, Il. 62903 618-457-8991 fax Page 1 of 1

Bridge Foundation Boring Log

Project: H-08083 Bridge _____ Date: 5-6-08
Section: 06-08134-00-BR Station _____
Structure: 097-3064 Bored by: D. Russell
County: White Checked By: T. Holcomb

Boring No:	Elevation	N	Qu tsf	w %	Surface Water Elev.	Elevation	N	Qu tsf	w %
2									
Station:					Ground Water Elev. 353.54				
Offset:					During Drilling 60.9				
					Upon Completion plugged				
Ground Surface 392.54-00.9	0				silty clay (continued)				
3" Crushed Stone 392.34-00.7									
Brown Clayey SAND (A-2-4)		13	1.0S	15	368.54-75.9		6	1.6B	24
					366.04-73.4				
		8		14			3	1.7B	22
Gray Mottled Brown Sandy CLAY (A-6)		8	1.4S	21			3	1.0B	21
Brown Sandy CLAY (A-6)		6	0.8B	22					
		5	1.3S	26					
		5	2.2B	25					
Gray Mottled Brown Silty CLAY to Clayey SILT (A-6 to A-4) with sand		5	1.4B	27	353.54-60.9				
		5	1.4B	27					
Brown Mottled Gray CLAY (A-7-6) with sand		5	1.9B	28					
Gray Silty CLAY (A-6) with sand		1	1.0B	32					

N = Standard Penetration Test Blows per foot to drive 2" O.D. Split Spoon Sampler 12" with a 140 lbs. hammer falling 30"
Qu - Unconfined Compressive Strength in tons/sq.ft.
w - Water Content - percentage of oven dry weight-%
B = Bulge Failure
S = Shear Failure
E = Estimated Value
P = Penetrometer

BORING 2

BORINGS
STRUCTURE NO. 097-3256

HAMPTON, LENZINI & RENWICK, INC. <small>CIVIL & STRUCTURAL ENGINEERS LAND SURVEYORS</small> HLR 3085 STEVENSON DRIVE, SUITE 201 SPRINGFIELD, ILLINOIS 62703 (217) 545-3400 PROJECT NUMBER: 06.0260.130 DATE: 10/15/09	SHEET NO. 8	T.R.	SECTION	COUNTY	TOTAL SHEETS	SHEET NO.
	8 SHEETS	128	06-08134-00-BR	WHITE	12	12
		INDIAN CREEK ROAD DISTRICT		CONTRACT NO. 99373		
		FED. ROAD DIST. NO.	ILLINOIS	FED. AID PROJECT BROS-193(30)		