

STATE OF ILLINOIS  
DEPARTMENT OF TRANSPORTATION

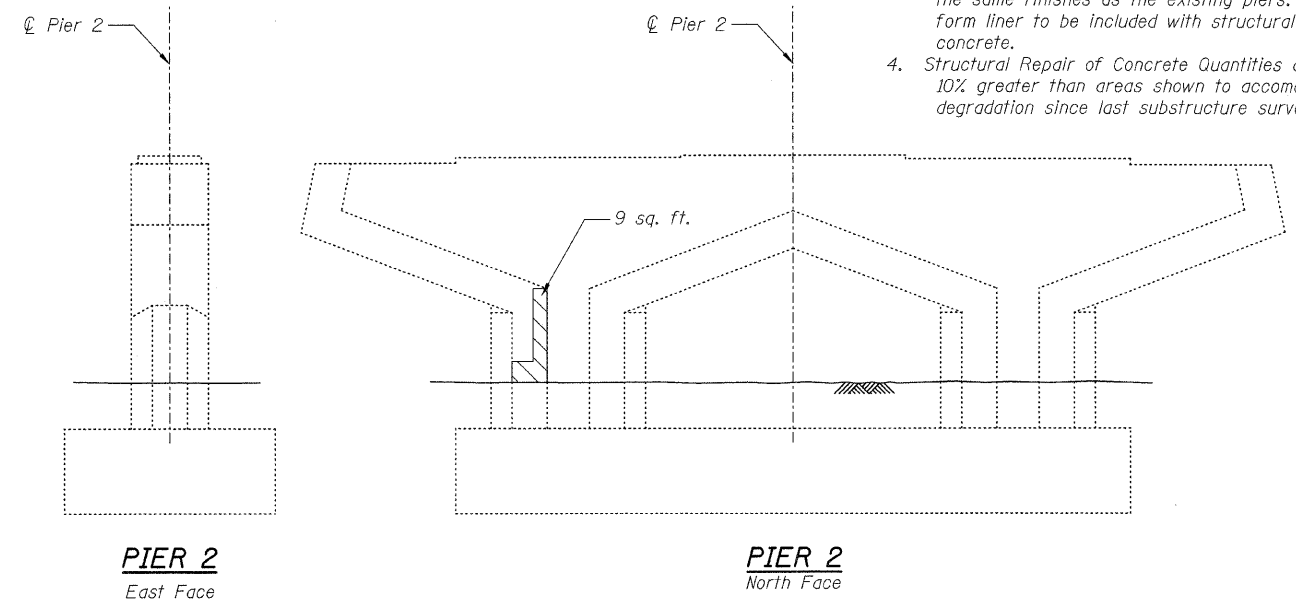
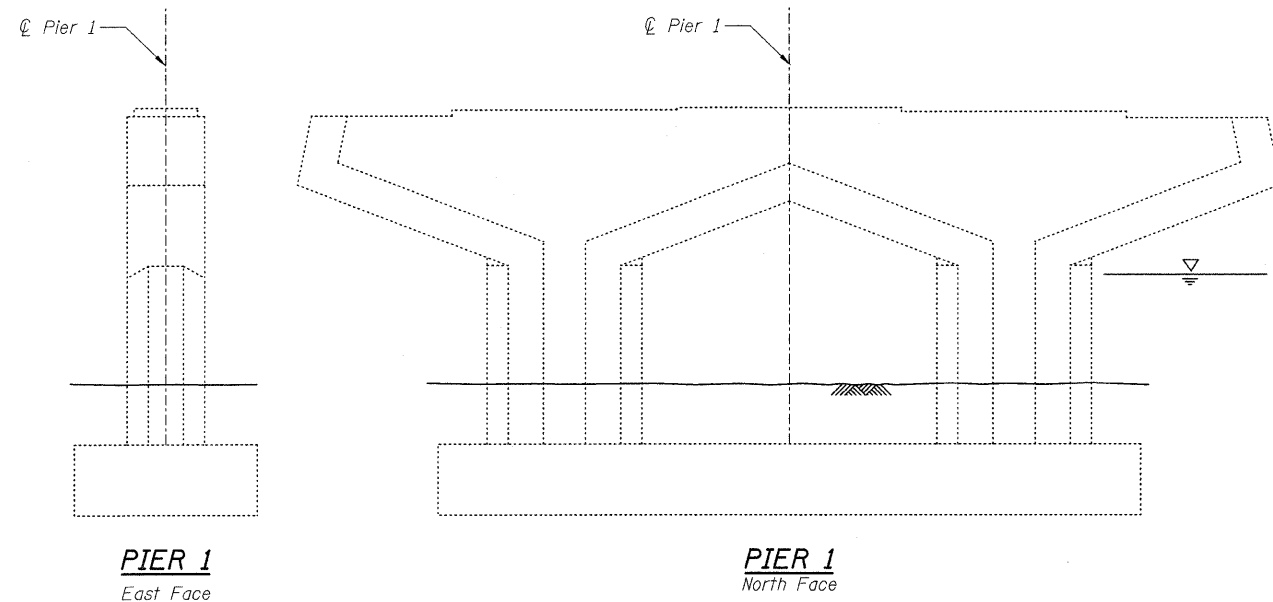
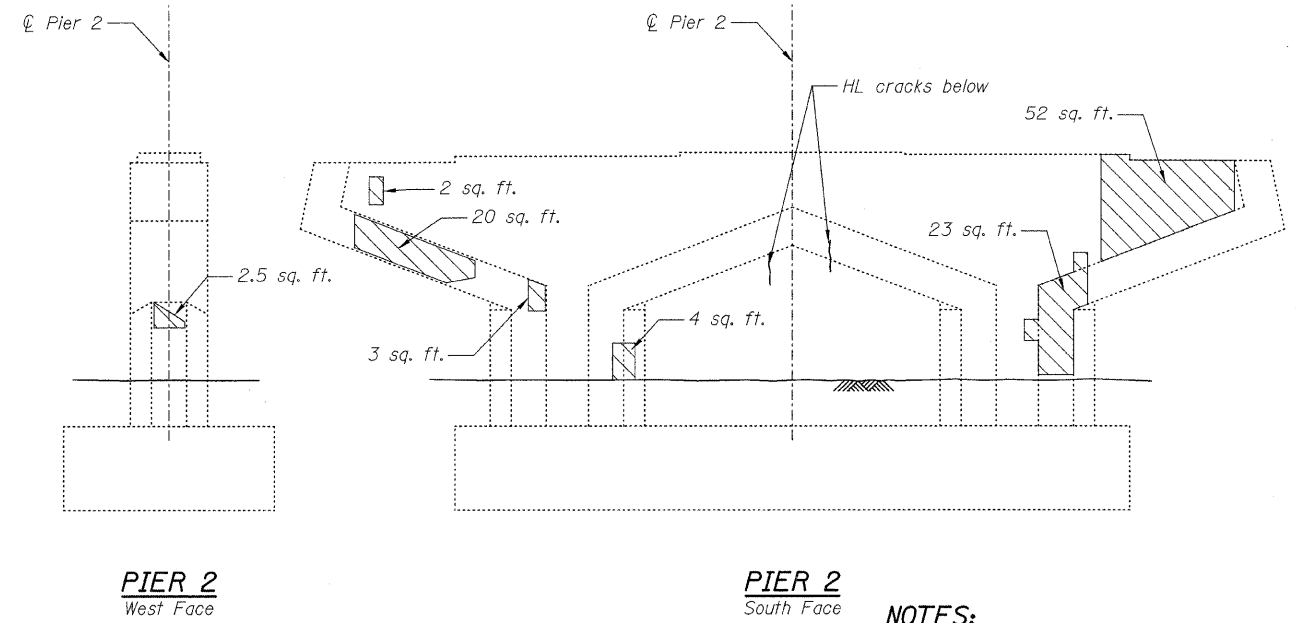
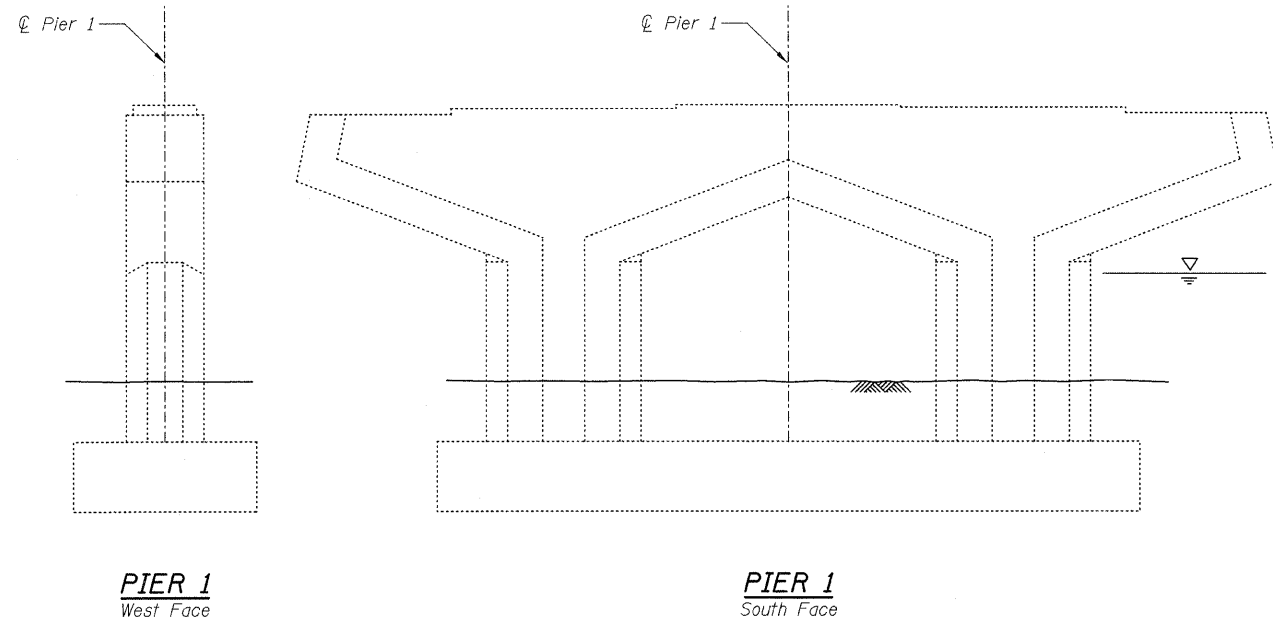

**NOTES:**

1. Repairs shall include but not be limited to the areas shown. The actual areas to be repaired will be determined by engineer at the time of construction.
2. The contractor is ultimately responsible for the means and methods to assure the complete stability of the structural members during construction.
3. Concrete repairs on the piers should match the same finishes as the existing piers. Cost of form liner to be included with structural repair of concrete.
4. Structural Repair of Concrete Quantities are 10% greater than areas shown to accommodate for degradation since last substructure survey.

**LEGEND**

- HL Hairline Crack (No Repairs)
- Structural Repair of Concrete (Depth Equal to or Less than 5 inches)

**BILL OF MATERIAL**

ITEM	UNIT	QUANTITY
Structural Repair of Concrete (Depth Equal to or Less than 5 inches)	Sq. Ft.	127

**PIERS 1 & 2**  
**S.N. 016-0540**

DESIGNED	B. Sauter
CHECKED	E. Mroczek
DRAWN	R. Danley
CHECKED	B. Sauter



**Giorba Group, Inc.**  
CONSULTING ENGINEERS  
5507 North Cumberland Avenue, Suite 402 Chicago, Illinois 60656  
Tel. 773.775.4009 Fax 773.775.4014 Email chicago@giorba.com

SHEET NO. S-19	F.A.U. RTE.	SECTION	COUNTY	TOTAL SHEETS	SHEET NO.
	2697	142 B-1-I	COOK	48	33
S-27 SHEETS			CONTRACT NO. 60D89		
FED. ROAD DIST. NO.		ILLINOIS	FED. AID PROJECT		

rdanley  
 2/4/2009  
 n:\pro\3329\3329\_30\Design\structural\lead\it\concrete\_repairs\3329\_30\_19\_Piers 1 & 2.dwg