

F.A.I. RTE.	SECTION	COUNTY	TOTAL SHEETS	SHEET NO.
90/94	02026-2P, ETC, 1415 & 1517R-7	COOK	246	13
STA.	TO STA.	ILLINOIS FED. AID PROJECT		
FED. ROAD DIST. NO.	CONTRACT NO. 62408			

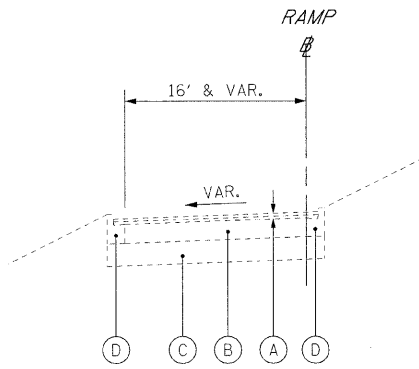

EXISTING OFF RAMP

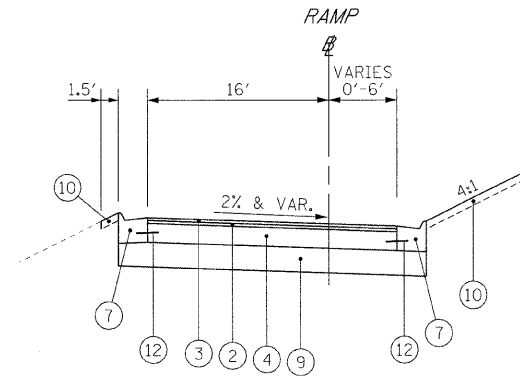

PROPOSED RAMP "K"

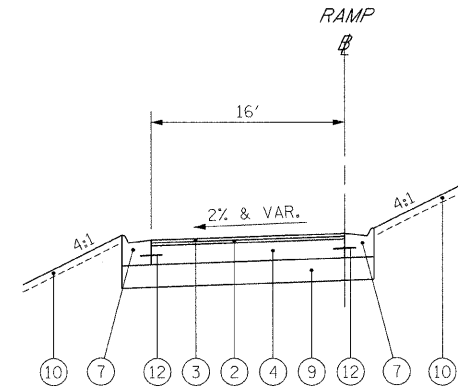

RAMP "F" & "H"

NOTE: ON RAMP F THE 2% CROWN AS SHOWN IS REVERSED FROM STA. 10+98.34 TO STA. 13+64

EXISTING LEGEND

- (A) EXISTING ±4" HMA RESURFACING
- (B) EXISTING PCC PAVEMENT, 10" WITH PAVEMENT FABRIC
- (C) EXISTING SUBBASE
- (D) EXISTING CURB AND GUTTER
- (E) EXISTING BARRIER WALL (SINGLE OR DOUBLE FACE)
- (F) EXISTING HMA SHOULDER
- (G) EXISTING HMA MEDIAN SURFACE

PROPOSED LEGEND

- (1) EXISTING PAVEMENT AND RESURFACING (SEE EXIST. TYPICALS)
- (2) HOT-MIX ASPHALT BINDER COURSE, IL 19.0, N70, 2 1/2"
- (3) HOT-MIX ASPHALT SURFACE COURSE, MIX D, N70, 1 1/2"
- (4) PORTLAND CEMENT CONCRETE BASE COURSE 10"
- (5) PORTLAND CEMENT CONCRETE BASE COURSE WIDENING 10"
- (6) HOT-MIX ASPHALT SHOULDERS, 10" (TOP LIFT WILL BE A MINIMUM OF 2 1/4")
- (7) COMBINATION CONCRETE CURB AND GUTTER, TYPE M-4.24
- (8) CONCRETE BARRIER, SINGLE FACE
- (9) AGGREGATE SUBGRADE 12"
- (10) TOPSOIL FURNISH AND PLACE, 4" & SODDING, SALT TOLERANT
- (11) DRILL AND GROUT NO. 8 TIE BARS, 24" LONG, 24" O.C. "INCLUDED IN THE COST OF PORTLAND CEMENT CONCRETE BASE COURSE WIDENING"
- (12) DRILL AND GROUT NO. 6 TIE BARS, 24" LONG, 24" O.C. "INCLUDED IN THE COST OF COMBINATION CONCRETE CURB AND GUTTER, TYPE M-4.24"
- (13) EXISTING CURB AND GUTTER TO REMAIN

NOTE: BOXED ITEMS IN LEGEND ARE INCLUDED IN THE COST OF OTHER CONTRACT PAY ITEMS AND WILL NOT BE PAID FOR SEPERATELY.

ILLINOIS DEPARTMENT OF TRANSPORTATION

TYPICAL SECTIONS
EXISTING & PROPOSED
I-90/94 KENNEDY EXPRESSWAY

SCALE : NTS
DATE : 02/06/09
DRAWN BY : BEC
CHECKED BY : GB

PLAN	DATE	BY
NO.		
NO.		
NO.		
NO.		

PROFILE	DATE	BY
NO.		
NO.		
NO.		
NO.		