

STATE OF ILLINOIS
DEPARTMENT OF TRANSPORTATION

ROUTE NO.	SECTION	COUNTY	SHEET NO.	SHEET NO.
F.A.P. 90/94	*	COOK	246	191
FED. ROAD DIST. NO. 7		ILLINOIS	FED. AID PROJECT-	

*SECT. (202.6-2P, ETC, 1415 & 1517)R-7
Contract # 62408

SHEET NO. 09

09 SHEETS

Joint Size	"C" at 50°F	"D" at 50°F
2"	2"	1 1/2" Min.
2 1/2"	2 1/2"	1 3/4" Min.
4"	3"	2 1/2" Min.

INSTALLATION NOTES

- Install continuous seal in roadway, parapet, curb, and sidewalk.
- Install anchor blocks as indicated.

Note A:
Maximum spacing of anchor bolts shall be 12" centers.

SKEW LIMITATIONS

The details of the anchor blocks and the elastomeric membrane in the parapet, as shown, are for up to 50° skews. For skews greater than 50°, the anchor blocks and the elastomeric membrane, installed according to dimension "D", might require modifications to insure a minimum clearance of 1 1/2" from centerline of anchor studs to edge of parapet opening. The anchor blocks and the elastomeric membrane shall also be installed to the top of the parapet with the anchor studs spaced at ±12" cts.

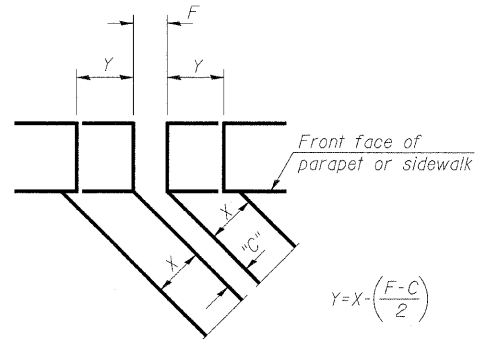

$$Y = X \cdot \left(\frac{F-C}{2} \right)$$

For dimension "F" see sheet #

FORMING BLOCKOUT SKETCH

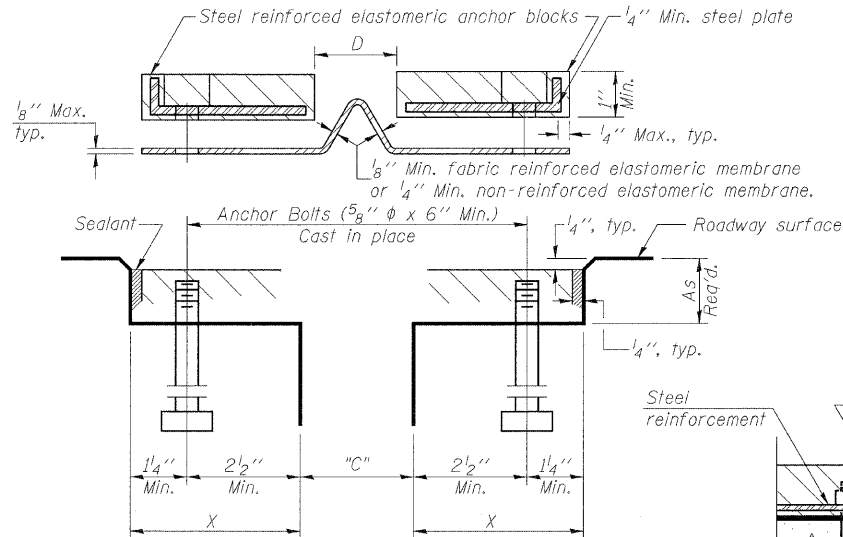

CROSS SECTION

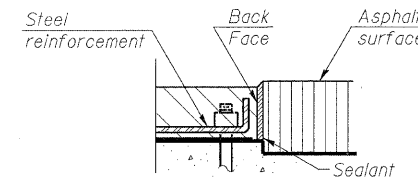

ANCHOR BLOCK WITH ASPHALT SURFACE

GENERAL NOTES

Continuous Seal Neoprene Expansion Joint shall consist of molded anchor blocks of elastomer and steel, field assembled over continuous lengths of elastomeric membrane.

The elastomeric membrane shall be premolded with a single or a double upward convolution that will have a "memory" to return to its molded position upon joint closure.

The convolution length shall be such that the extended length will not be greater than the manufactured length when the joint is fully expanded in its design range and will not protrude above the anchor blocks when the joint is fully compressed.

Joint openings shall be adjusted according to Article 503.10(c) of the Standard Specifications when the deck is poured at an ambient temperature other than 50° F.

The parapet and roadway membrane shall be made continuous by an approved vulcanizing process. Lapping will not be permitted.

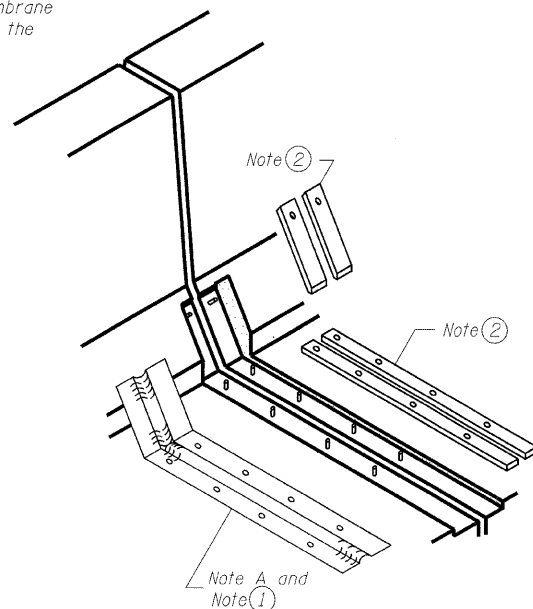

AT PARAPET

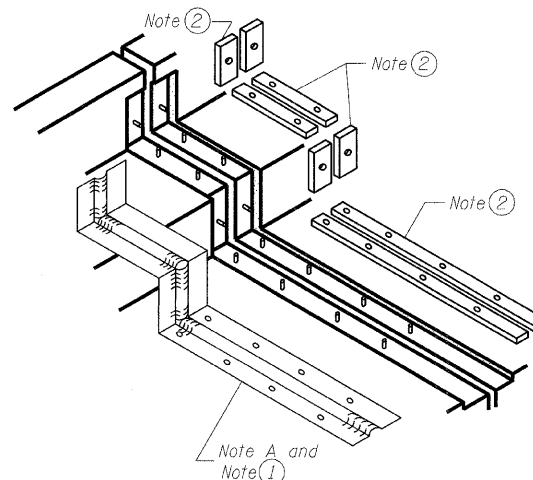

AT SIDEWALK OR MEDIAN

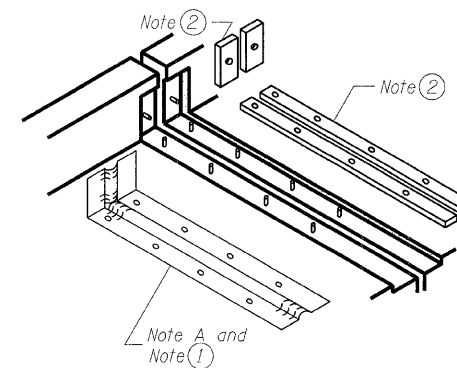

AT WALL

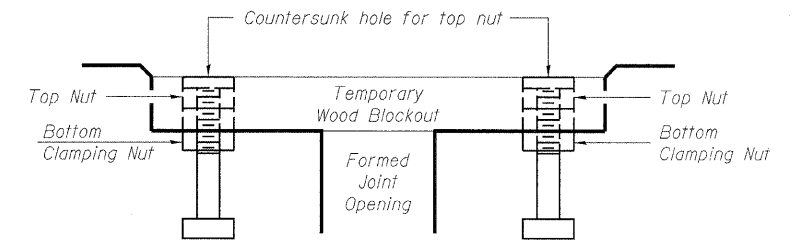

Note:
Stud needs to be threaded lower to allow for use of clamping nut.

RECOMMENDED BLOCKOUT DETAIL

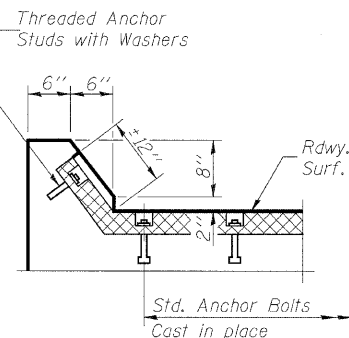

AT CURB

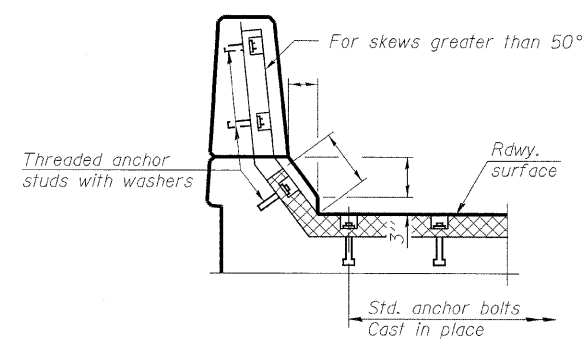

AT PARAPET

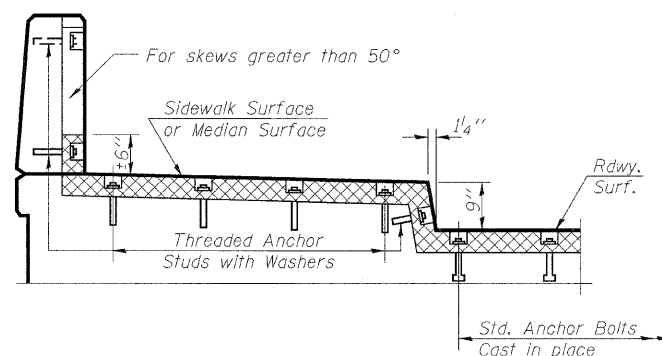

**AT SIDEWALK OR MEDIAN
TYPICAL END TREATMENTS**

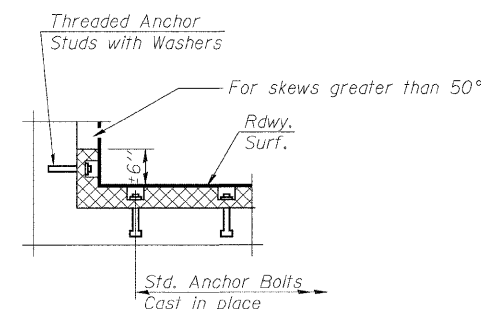

AT WALL

DESIGNED	ASP
CHECKED	WSP
DRAWN	BEM
CHECKED	ASP

**CONTINUOUS SEAL TYPE
NEOPRENE EXPANSION JOINTS
I-90/94 KENNEDY EXPRESSWAY
(HUBBARDS CAVE TO I-290)
SECTION (202.6-2P, ETC, 1415 & 1517)R-7
COOK COUNTY
STRUCTURE NO. 016-W985**

DLZ 85 W. Algonquin Rd. Ste. 220
Arlington Heights IL 60005
DLZ Illinois, Inc.