

STATE OF ILLINOIS
DEPARTMENT OF TRANSPORTATION

ROUTE NO.	SECTION	COUNTY	TOTAL SHEETS	SHEET NO.	SHEET NO.
F.A.P. 90/94	*	COOK	246	203	07 SHEETS
FED. ROAD DIST. NO. 1		ILLINOIS	FED. AID PROJECT		

*SECT. (202.6-2P, ETC, 1415 & 1517)R-7
Contract # 62408

BILL OF MATERIAL

Bar	No.	Size	Length	Shape
d1(E)	24	5	1'-7"	
d1(E)	15	7	4'-4"	
d2(E)	12	8	3'-2"	
d3(E)	12	5	1'-8"	
d4(E)	3	5	1'-11"	
d5(E)	202	5	3'-0"	
d6(E)	130	5	4'-9"	
d7(E)	24	5	3'-10"	
d8(E)	5	5	6'-0"	
d9(E)	5	5	4'-2"	
d10(E)	4	5	8'-7"	
d11(E)	1	5	7'-2"	
d12(E)	5	8	8'-9"	
d13(E)	5	5	6'-1"	
d14(E)	5	5	9'-9"	
d15(E)	1	5	8'-10"	
d16(E)	1	5	7'-10"	
d17(E)	5	9	8'-11"	
d18(E)	5	5	6'-9"	
d19(E)	5	5	10'-11"	
d20(E)	1	5	9'-8"	
d21(E)	1	5	8'-2"	
d22(E)	6	9	9'-5"	
d23(E)	6	5	7'-10"	
d24(E)	5	5	13'-0"	
d25(E)	1	5	11'-8"	
d26(E)	1	5	10'-2"	
d27(E)	1	5	8'-8"	
h(E)	22	6	1'-8"	
h1(E)	38	6	32'-1"	
h2(E)	30	6	27'-9"	
h3(E)	24	6	29'-7"	
h4(E)	12	5	2'-2"	
v(E)	3	5	20'-2"	
v1(E)	29	5	22'-2"	
v2(E)	2	5	10'-2"	
v3(E)	28	5	25'-8"	
v4(E)	2	5	11'-11"	
v5(E)	26	5	29'-6"	
v6(E)	2	5	13'-9"	
v7(E)	6	5	4'-3"	
v8(E)	4	5	10'-7"	
v9(E)	6	5	12'-6"	
v10(E)	6	5	11'-11"	
v11(E)	6	5	11'-5"	
v12(E)	6	5	10'-11"	
v13(E)	6	5	10'-3"	
v14(E)	6	5	9'-10"	
v15(E)	6	5	9'-4"	
v16(E)	6	5	8'-10"	
v17(E)	6	5	8'-3"	
v18(E)	6	5	7'-10"	
v19(E)	2	5	13'-6"	
CONCRETE STRUCTURES				CU. YD. 61.1
REINFORCEMENT BARS, EPOXY COATED				POUND 9,910

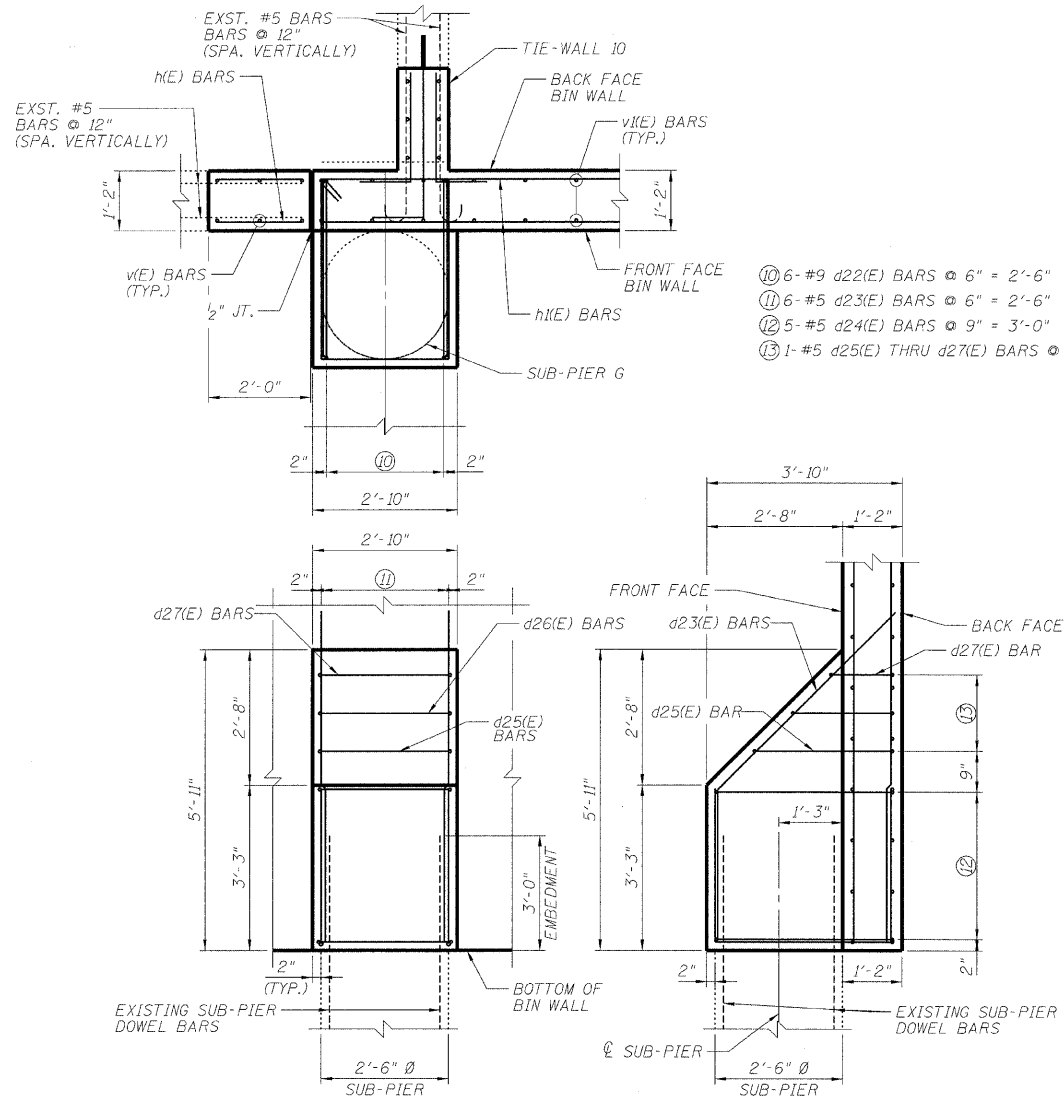

CORBEL @ SUB-PIER I

- ⑩ 6-#9 d22(E) BARS @ 6" = 2'-6"
- ⑪ 6-#5 d23(E) BARS @ 6" = 2'-6"
- ⑫ 5-#5 d24(E) BARS @ 9" = 3'-0"
- ⑬ 1-#5 d25(E) THRU d27(E) BARS @ 9" = 1'-6"

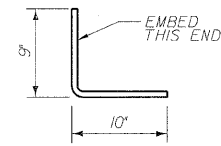

BAR d(E)

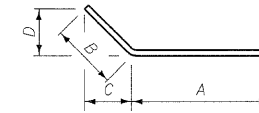

BARS d1(E), d9(E), d13(E), d18 OR d23(E)

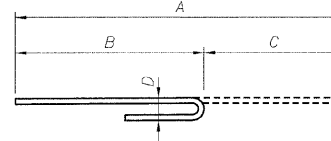

BARS d2(E) THRU d4(E)

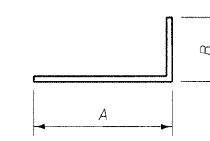

BARS d5(E) OR d6(E)

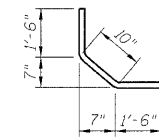

BAR d7(E)

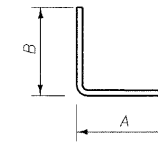

BARS d8(E), d12(E), d17(E) OR d22(E)

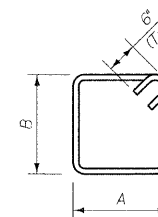

BARS d10(E), d11(E), d14(E) THRU d16(E), d19(E) THRU d21(E), OR d24(E) THRU d27(E)

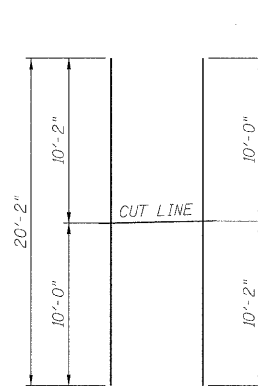

BAR v(E)

3 BARS-1 SET
(USE REMAINDER OF BARS
IN OPPOSITE FACE)

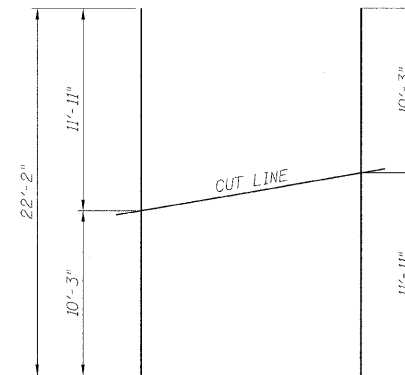

BAR v1(E)

29 BARS-1 SET
(USE REMAINDER OF BARS
IN OPPOSITE FACE)

BAR BENDING DIAGRAMS

Bar	A		B		C		D	
	Ft.	In.	Ft.	In.	Ft.	In.	Ft.	In.
d1(E)	2	10	1	6	1	0 3/4	1	0 3/4
d2(E)	3	2	2	3	0	11	0	8
d3(E)	1	8	1	1	0	7	0	5
d4(E)	1	11	1	4	0	7	0	5
d5(E)	2	0	1	0				
d6(E)	3	9	1	0				
d8(E)	1	6	2	3				
d9(E)	2	3	1	11	1	4	1	4
d10(E)	2	3	1	6 1/2				
d11(E)	2	3	0	10				
d12(E)	2	1	3	4				
d13(E)	3	4	2	9	2	0	2	0
d14(E)	2	3	2	1 1/2				
d15(E)	2	3	1	8				
d16(E)	2	3	1	2				
d17(E)	2	7	3	2				
d18(E)	3	7	3	2	2	2	2	2
d19(E)	2	3	2	8 1/2				
d20(E)	2	3	2	1				
d21(E)	2	3	1	4				
d22(E)	3	5	3	0				
d23(E)	4	10	3	0	2	1 1/2	2	1 1/2
d24(E)	2	6	3	6				
d25(E)	2	6	2	10				
d26(E)	2	6	2	1				
d27(E)	2	6	1	4				

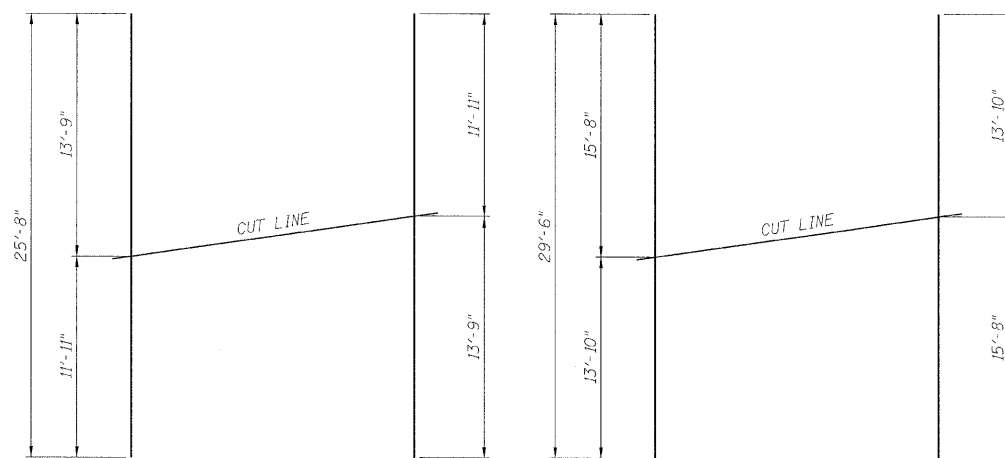

BAR v3(E)

28 BARS-1 SET
(USE REMAINDER OF BARS
IN OPPOSITE FACE)

BAR v5(E)

26 BARS-1 SET
(USE REMAINDER OF BARS
IN OPPOSITE FACE)

BAR CUTTING DIAGRAMS

DESIGNED	ASP
CHECKED	LNB
DRAWN	BEM
CHECKED	ASP

RAMPS 'L' & 'M' BARBILL & DETAILS
I-90/94 KENNEDY EXPRESSWAY
(HUBBARDS CAVE TO I-290)
SECTION (202.6-2P, ETC, 1415 & 1517)R-7
COOK COUNTY
STRUCTURE NO. 016-W987