

STATE OF ILLINOIS
DEPARTMENT OF TRANSPORTATION

ROUTE NO.	SECTION	COUNTY	DATE	SHEET NO.	SHEET NO. 06 07 SHEETS
F.A.P. 90/94	*	COOK	2006	2004	
FED. ROAD DIST. NO. 1		ILLINOIS	FED. AID PROJECT		

*SECT. (202.6-2P, ETC, 1415 & 1517)R-7
Contract # 62408

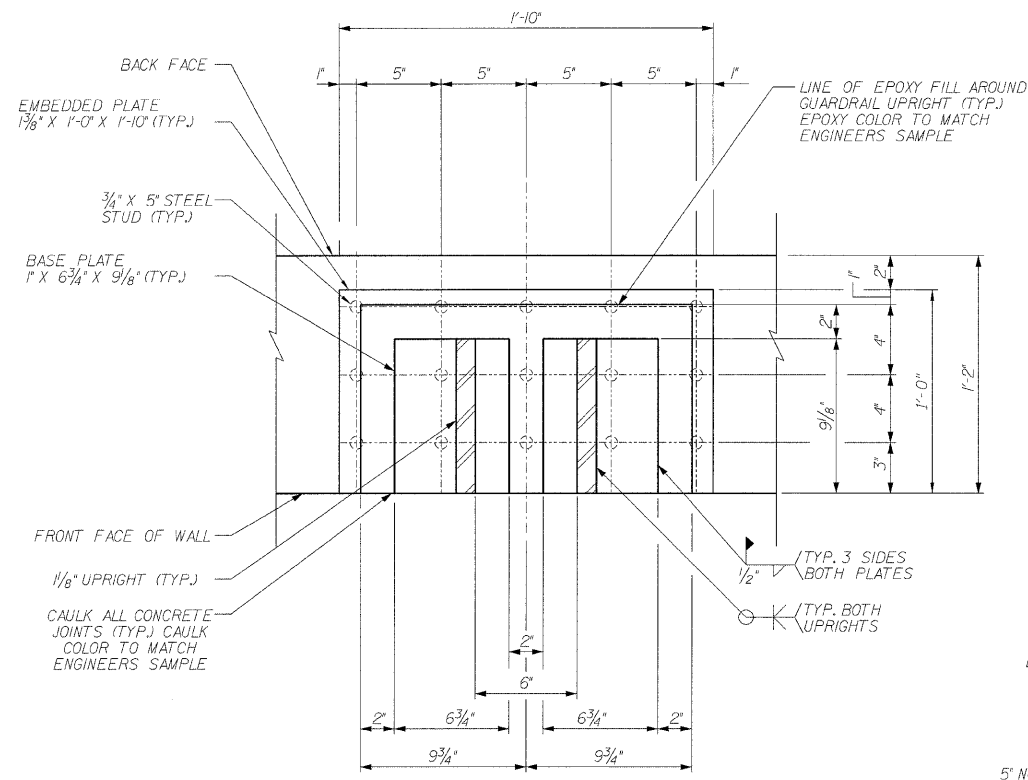

EMBEDDED PLATE, GUARDRAIL UPRIGHT
(AT TOP OF PLATE)

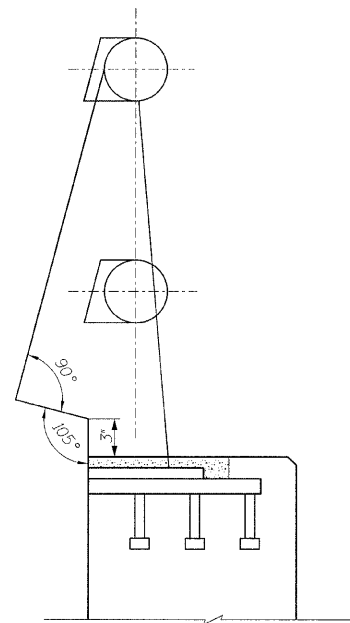

ELEVATION W/OUT DECORATIVE FASCIA
(SEE ELEVATION W/DECORATIVE FASCIA FOR DIMENSIONS)

DESIGNED	ASP
CHECKED	LNB
DRAWN	BEM
CHECKED	ASP

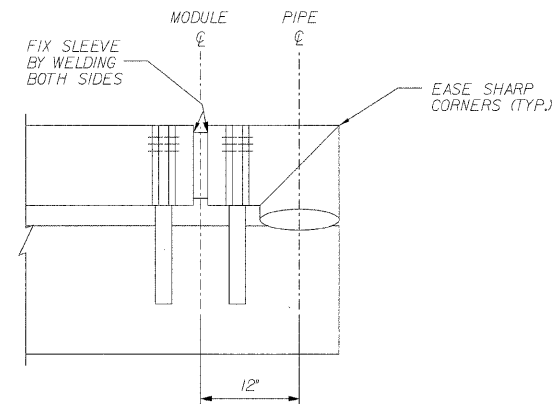

**GUARDRAIL END
CONDITION PLAN**

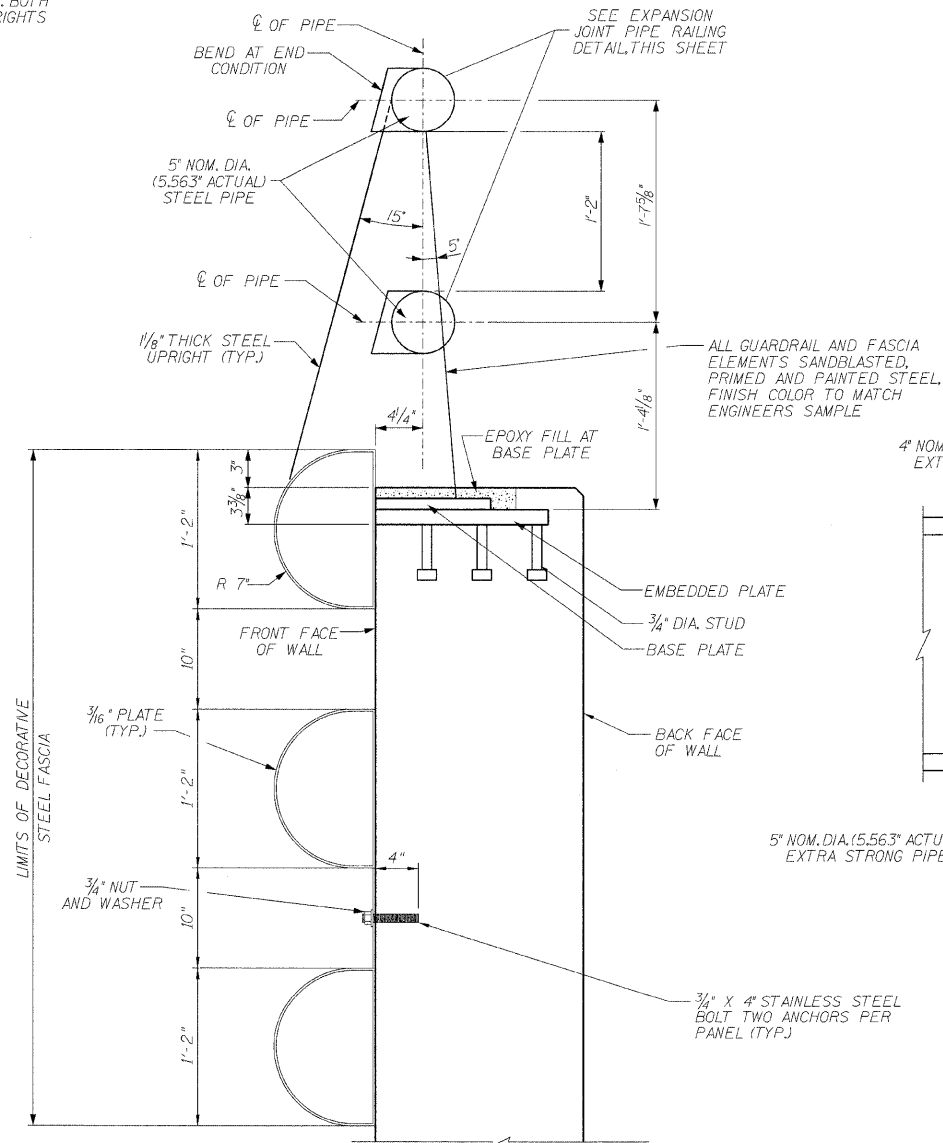

ELEVATION W/DECORATIVE FASCIA

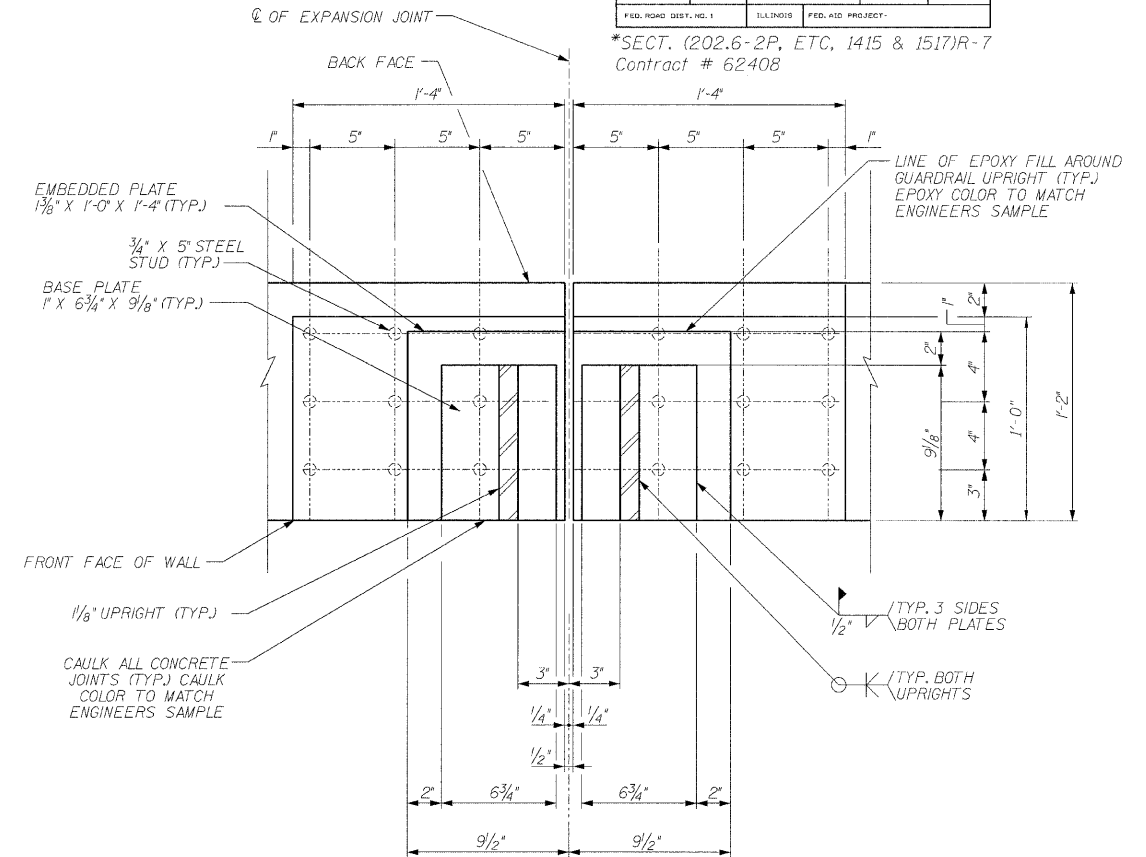

**EMBEDDED PLATE, GUARDRAIL
UPRIGHT AT EXPANSION JOINT**
(AT TOP OF PLATE)

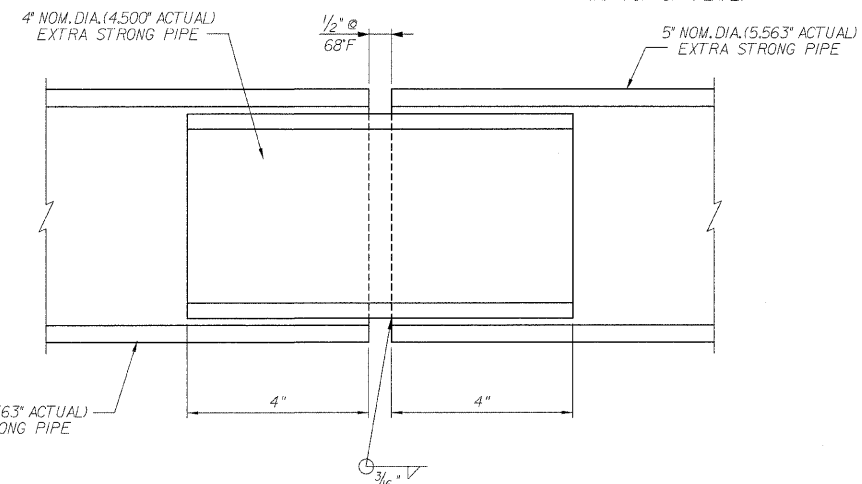

EXPANSION JOINT PIPE RAILING
(SHOWN ALONG Q. OF PIPE)

RAMPS 'L' & 'M' RAILING SYSTEM DETAILS
I-90/94 KENNEDY EXPRESSWAY
(HUBBARDS CAVE TO I-290)
SECTION (202.6-2P, ETC, 1415 & 1517)R-7
COOK COUNTY
STRUCTURE NO. 016-W987