

F.A. RTE.	SECTION	COUNTY	TOTAL SHEETS	SHEET NO.
			101	090
STA.		TO STA.		
FED. ROAD DIST. NO.		ILLINOIS FED. AID PROJECT		

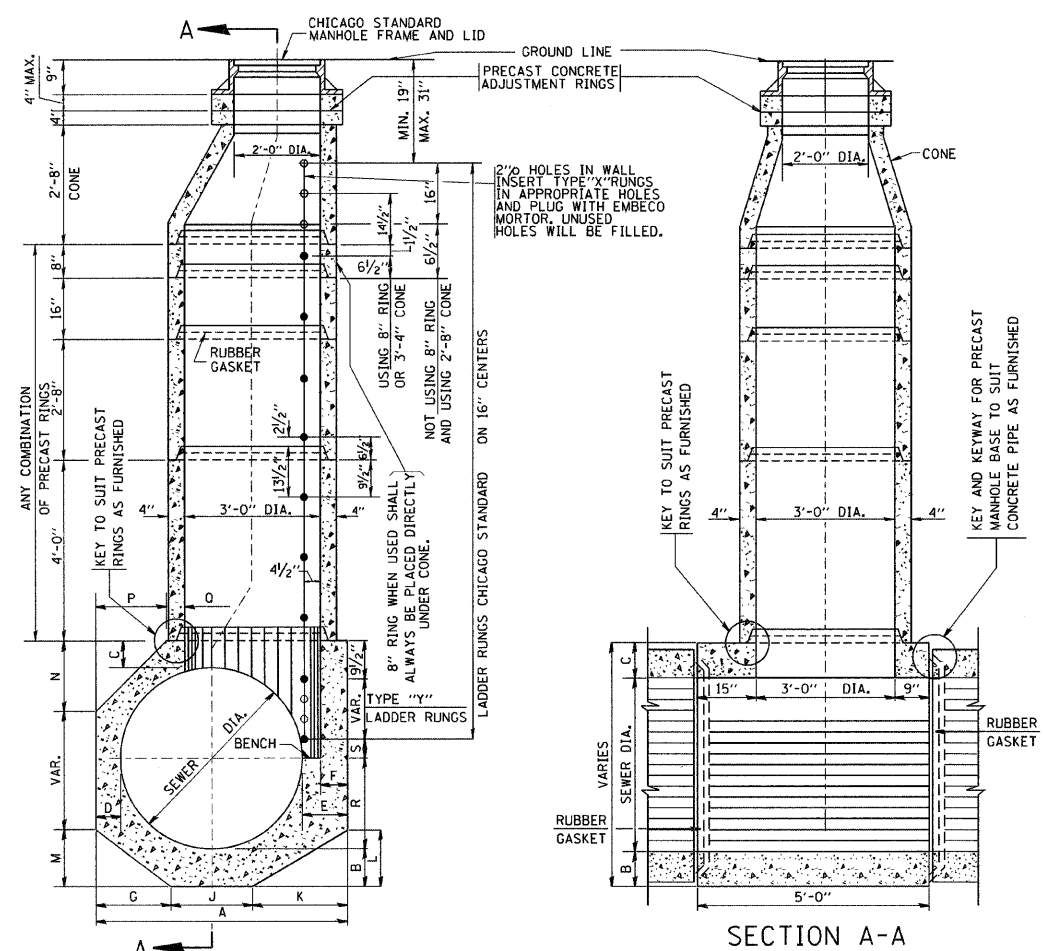

**TYPE "A" MANHOLE**  
FOR SEWERS  
24" TO 120" DIAMETER  
PRECAST BASES AND RINGS

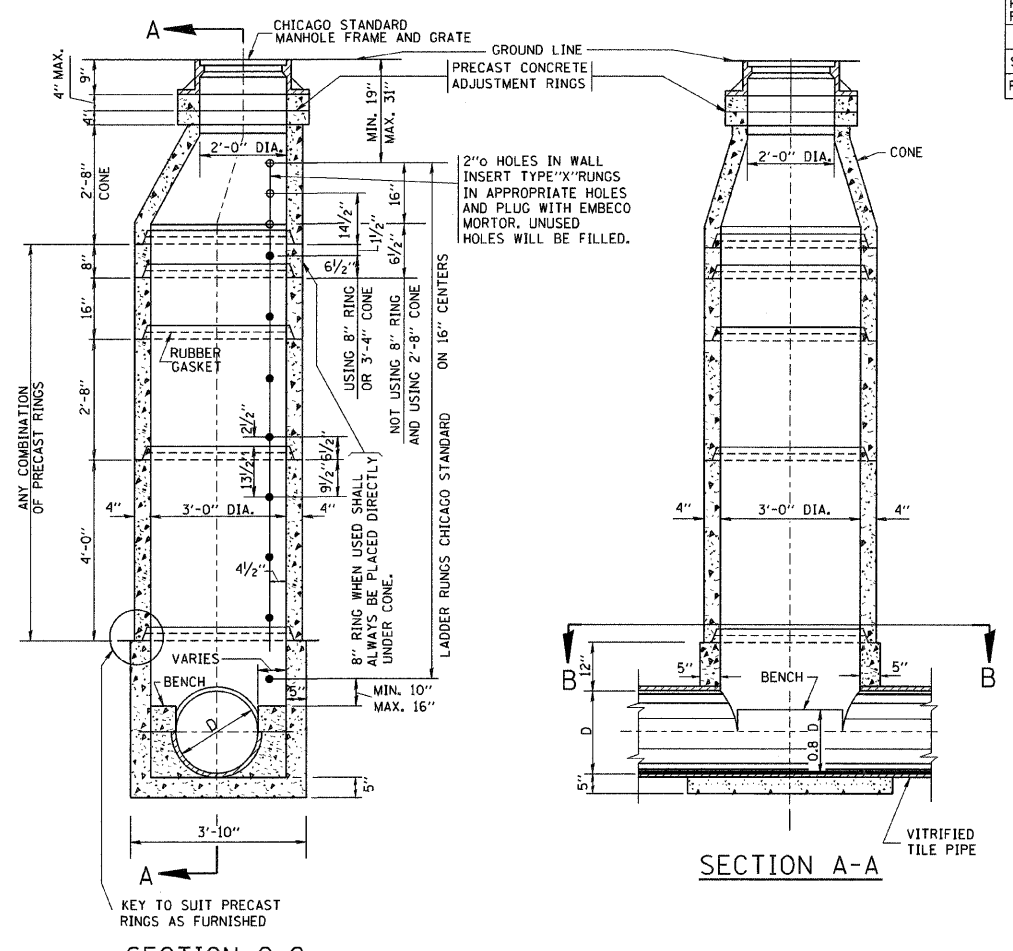

**TYPE "A" MANHOLE**  
FOR SEWERS  
21" DIAMETER AND SMALLER  
PRECAST BASES AND RINGS

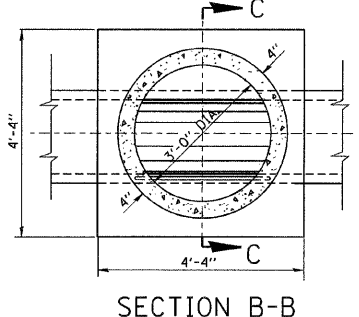
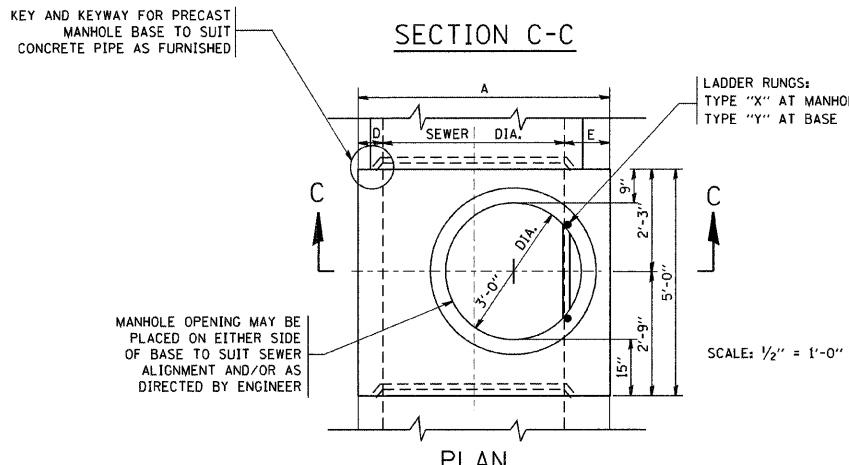

SEWER DIA.	PART OF ITEM	DIMENSIONS OF PRECAST MANHOLE BASE															NO. "Y" RINGS	
		A	B	C	D	E	F	G	J	K	L	M	N	P	O	R		
120"	----	12'-4 1/2"	12"	12"	12"	16 1/2"	12"	4'-0"	4'-4 1/2"	2'-7 1/2"	2'-5"	3'-7"	3'-7"	4'-8 1/2"	2'-0"	2 1/2"	7	
108"	----	11'-4 1/2"	12"	12"	12"	16 1/2"	12"	3'-8"	3'-8"	4'-0 1/2"	2'-5"	2'-2"	3'-4"	3'-4"	4'-0 1/2"	2'-0"	6 1/2"	6
102"	----	10'-10 1/2"	12"	12"	12"	16 1/2"	12"	3'-6"	3'-6"	3'-10 1/2"	2'-4"	2'-1"	3'-2"	3'-2"	3'-8 1/2"	2'-0"	16 1/2"	5
96"	10-A	10'-2 1/2"	11"	11"	11"	15 1/2"	11"	3'-3"	3'-3"	3'-8 1/2"	2'-3"	2'-11"	2'-11"	3'-4 1/2"	2'-0"	9 1/2"	5	
90"	10-B	9'-8 1/2"	11"	11"	11"	15 1/2"	11"	3'-1"	3'-1"	3'-6 1/2"	2'-1 1/2"	2'-10"	2'-10"	2'-11 1/2"	2'-0"	3 1/2"	5	
84"	10-C	9'-0 1/2"	10"	10"	10"	14 1/2"	10"	2'-11"	2'-11"	3'-2 1/2"	2'-3"	2'-7"	2'-7"	2'-7 1/2"	2'-0"	12 1/2"	4	
78"	10-D	8'-6 1/2"	10"	10"	10"	14 1/2"	10"	2'-9"	2'-9"	3'-0 1/2"	2'-2"	2'-6"	2'-6"	2'-2 1/2"	2'-0"	6 1/2"	4	
72"	10	7'-10 1/2"	9"	9"	9"	13 1/2"	9"	2'-6"	2'-6"	2'-10 1/2"	2'-1"	2'-3"	2'-3"	2'-2 1/2"	2'-0"	15 1/2"	3	
66"	11	7'-4 1/2"	9"	9"	9"	13 1/2"	9"	2'-4"	2'-4"	2'-8 1/2"	19 1/2"	17"	2'-1"	2'-1"	18 1/2"	2'-0"	9 1/2"	3
60"	12	6'-8 1/2"	8"	8"	8"	12 1/2"	8"	2'-1 1/2"	2'-1"	2'-6"	18"	15"	2'-3"	2'-3"	13 1/2"	2'-0"	2 1/2"	3
54"	13	6'-2 1/2"	8"	8"	8"	12 1/2"	8"	2-3 3/4"	2-3"	2'-4"	17"	14"	2'-1"	2'-1"	9 1/2"	2'-0"	12 1/2"	2
48"	14	5'-6 1/2"	7"	7"	7"	11 1/2"	7"	2'-0 1/2"	2'-1"	2'-1"	15"	12 1/2"	18 1/2"	18 1/2"	5"	2'-0"	5 1/2"	2
42"	15	5'-0 1/2"	7"	7"	7"	11 1/2"	7"	18 1/2"	19"	2-3"	14"	11"	---	---	17 1/2"	2'-0"	2 1/2"	2
36"	16	4'-4 1/2"	6"	6"	6"	10 1/2"	6"	16"	16"	20 1/2"	12 1/2"	9 1/2"	---	---	10 1/2"	18"	14 1/2"	1
30"	17	4'-0"	6"	6"	6"	12"	6"	14"	14"	20"	12"	8 1/2"	---	---	6"	15"	11 1/2"	1
24"	18	4'-0"	6"	6"	6"	12"	6"	16"	16"	16"	9 1/2"	9 1/2"	---	---	6"	12"	8 1/2"	1

FOR STATE CONTRACT  
ALL DIMENSIONS SHOULD  
BE PREPARED IN METRIC  
UNITS. SOFT CONVERSION  
METHOD SHOULD BE USED.

REVISIONS	
NAME	DATE
	6-18-82
	9-22-90

ILLINOIS DEPARTMENT OF TRANSPORTATION  
  
**CITY OF CHICAGO  
DRAINAGE  
DETAILS**  
  
SCALE: VERT. NONE  
HORIZ.  
  
DRAWN BY  
CHECKED BY  
BD600-12 (BD-9)

PLOT DATE = 3/5/2007  
FILE NAME = K:\115110\115110.dgn  
PLOT SCALE = 50.0000 / IN.  
USER NAME = bboard