

BUTT JOINT DETAIL
N.T.S.

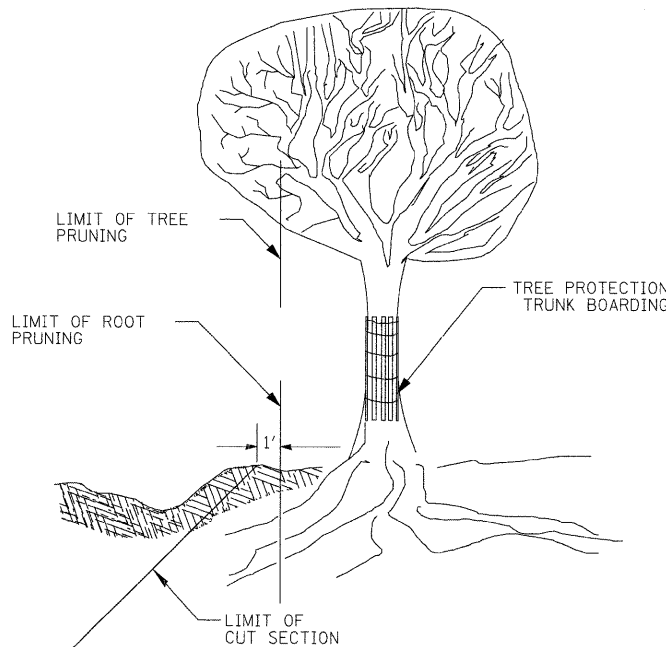

NOTE:
TREE AND ROOT PRUNING SHALL BE DONE IN ACCORDANCE WITH IDOT SPECIFICATION SECTION 201.

TREE TRUNK PROTECTION AND ROOT PRUNING DETAIL
N.T.S.

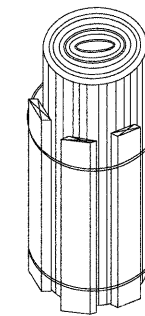

TREE PROTECTION TRUNK BOARDING DETAIL
N.T.S.

2"x10"x6'(MIN) PLANKS - NO. REQUIRED VARIES W/ SIZE OF TREE (4 MIN)
WIRE RETAINER NO 6 WIRE (MIN) WRAP AROUND BOARDS AND TWIST ENDS TOGETHER (BEND TWISTED ENDS TOWARD TREE)

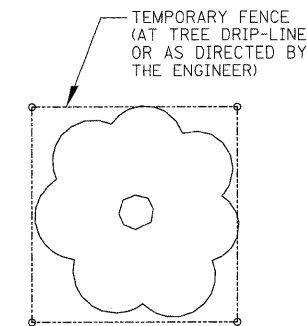

TEMPORARY FENCE DETAIL
N.T.S.

15" min. diameter round breakout or cored hole, typical for guardrail line posts (incidental to HMA Stabilization 6" at Steel Beam Plate Guard Rail).

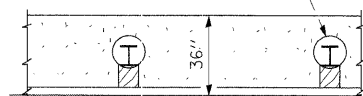

Back of Curb

Proposed HMA stabilization 36" & var.

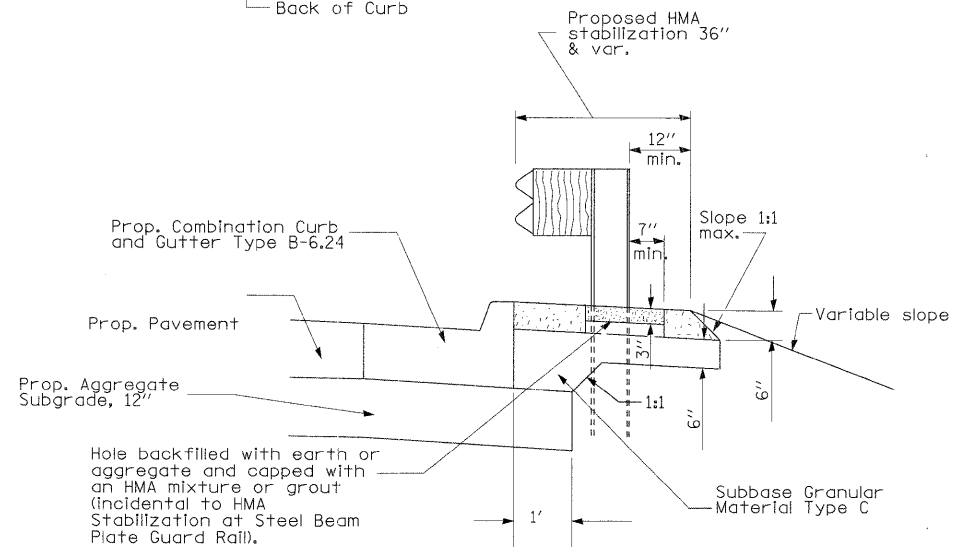

HMA STABILIZATION 6" AT STEEL BEAM PLATE GUARD RAIL BEHIND CURB AND GUTTER DETAIL
N.T.S.

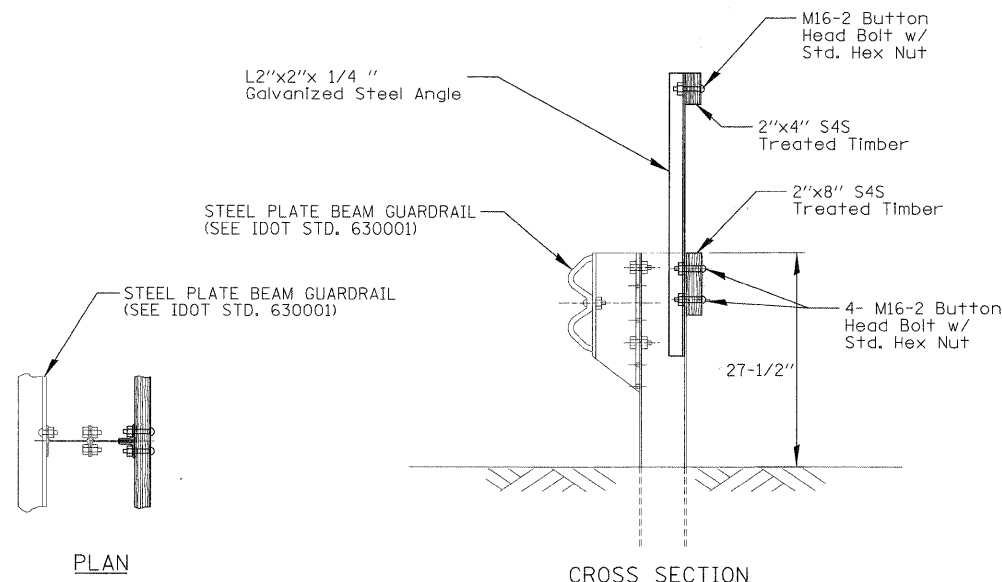

CROSS SECTION

RUB RAIL DETAIL
N.T.S.

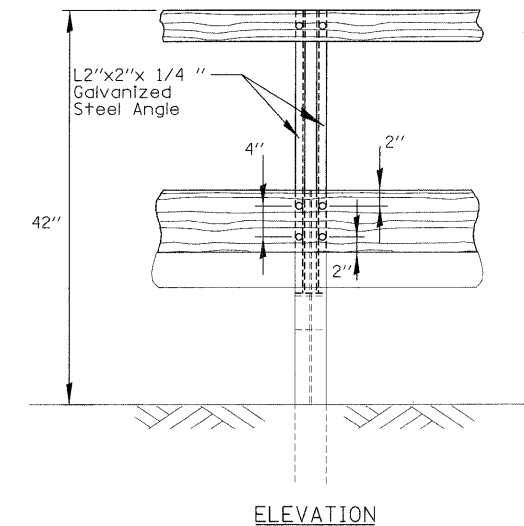

ELEVATION

FILE NAME = DET_070793_01.SHT	USER NAME = MWORMAN	DESIGNED - MCW	REVISED -	STATE OF ILLINOIS DEPARTMENT OF TRANSPORTATION	ROADWAY DETAILS				F.A.P. RTE.	SECTION	COUNTY	TOTAL SHEETS	SHEET NO.
	PLOT SCALE = 1"	DRAWN - GT	REVISED -						361	06-00214-20-BR	KANE	320	96
	PLOT DATE = 1/16/2009	CHECKED - MCW	REVISED -		CONTRACT NO. 63075								
	DATE - 01/16/09	REVISED -	FED. ROAD DIST. NO. 1 ILLINOIS FED. AID PROJECT										