

**PORTABLE SCALE TURNOUT PLAN**

\* MILLING TRANSITION FROM 1/2" TO 2/4" WILL BE PAID AS HMA SURF. REM. 2/4"

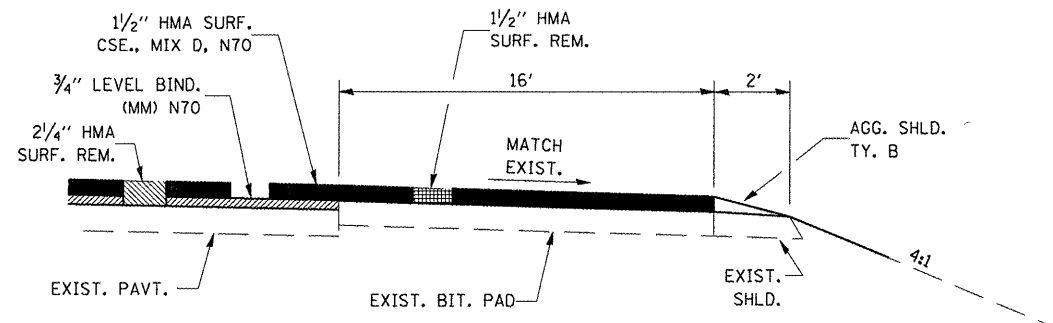

**SECTION A-A**

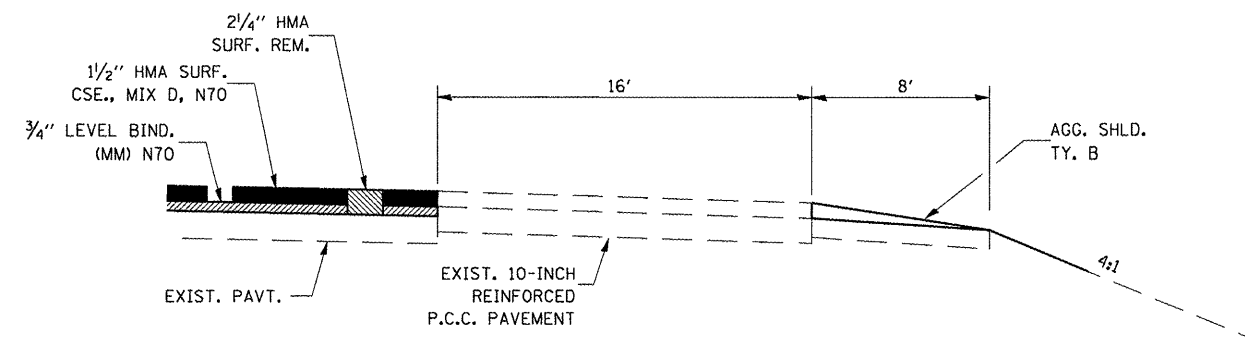

**SECTION B-B**

|                                       |  |            |           |
|---------------------------------------|--|------------|-----------|
| FILE NAME =                           | USER NAME = corcoranlm                 | DESIGNED - | REVISED - |
| ct:\pw\work\p\d\corcoranlm\d0119033\d | 66753-sht-detail.dgn                   | DRAWN -    | REVISED - |
|                                       | PLOT SCALE = 100.0000' / IN.           | CHECKED -  | REVISED - |
|                                       | PLOT DATE = Feb 10, 2009 - 09:29:06 AM | DATE -     | REVISED - |

**STATE OF ILLINOIS  
DEPARTMENT OF TRANSPORTATION**

**PORTABLE SCALE  
TURNOUT DETAILS**

SCALE: SHEET NO. OF SHEETS STA. TO STA.

|                    |                           |           |                           |           |
|--------------------|---------------------------|-----------|---------------------------|-----------|
| F.A.P. RTE.        | SECTION                   | COUNTY    | TOTAL SHEETS              | SHEET NO. |
| 326                | (119,120,121,122,123)RS-3 | GRU & LIV | 36                        | 28        |
| CONTRACT NO. 66753 |                           |           | ILLINOIS FED. AID PROJECT |           |