

F.A.I. RTE.	SECTION	COUNTY	TOTAL SHEETS	SHEET NO.
70		MADISON	420	216
STA.	TO STA.			
FED. ROAD DIST. NO.	ILLINOIS FED. AID PROJECT			
	• 60-10K-1, 60-10HB CONTRACT NO. 76709			

BILL OF MATERIAL RAMP "C"

Bar	No.	Size	Length	Shape
a ₅₂ (E)	67	#4	6'-8"	┌
a ₅₃ (E)	67	#4	5'-8"	┌
a ₅₄ (E)	14	#9	25'-3"	┌
a ₅₅ (E)	36	#9	16'-3"	┌
a ₅₆ (E)	88	#9	34'-9"	┌
a ₅₇ (E)	72	#5	22'-7"	┌
a ₅₈ (E)	27	#5	27'-0"	┌
a ₅₉ (E)	14	#4	4'-8"	┌
a ₆₀ (E)	14	#4	4'-2"	┌
a ₆₁ (E)	6	#4	5'-4"	┌
b ₅₅ (E)	52	#5	5'-3"	┌
b ₅₆ (E)	52	#5	6'-8"	┌
b ₅₇ (E)	90	#5	27'-11"	┌
b ₅₈ (E)	24	#4	27'-7"	┌
b ₅₉ (E)	10	#5	6'-4"	┌
b ₆₀ (E)	4	#4	5'-10"	┌
d(E)	59	#5	3'-2"	┌
d ₂ (E)	59	#4	3'-2"	┌
d ₅₂ (E)	57	#5	3'-0"	┌
d ₅₃ (E)	57	#4	3'-0"	┌
e ₅₆ (E)	12	#4	17'-0"	┌
e ₅₇ (E)	4	#8	28'-9"	┌
e ₅₈ (E)	4	#5	27'-7"	┌
e ₆₁ (E)	6	#4	18'-6"	┌
h ₅₂ (E)	6	#5	4'-4"	┌
h ₅₄ (E)	12	#5	8'-11"	┌
h ₅₅ (E)	18	#5	2'-4"	┌
h ₅₆ (E)	24	#5	4'-6"	┌
h ₅₈ (E)	48	#5	4'-4"	┌
h ₅₉ (E)	72	#5	22'-10"	┌
* Reinforcement Bars, Epoxy Coated	Pound	23,950		
* Concrete	Cu. Yd.	120		
* Preformed Joint Seal	Foot	74		
* Concrete Pad	Sq. Yd.	49		
* Polyethylene Bond Breaker	Sq. Yd.	49		
Bridge Approach Pavement (Special)	Sq. Yd.	238		

* Items included in the cost for Bridge Approach Pavement. (Special)

NOTES:

1. Thickness - "4" = thickness of pvmt.

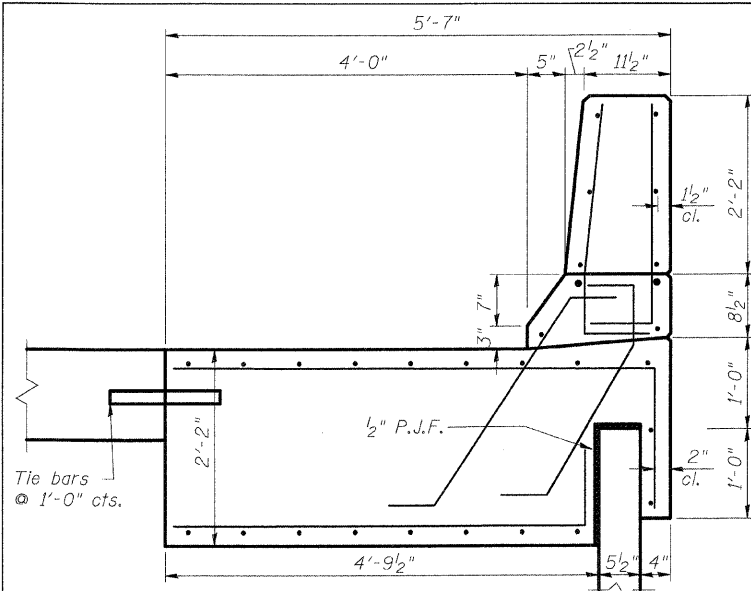

SECTION K-K
(S.N. 060-W003)

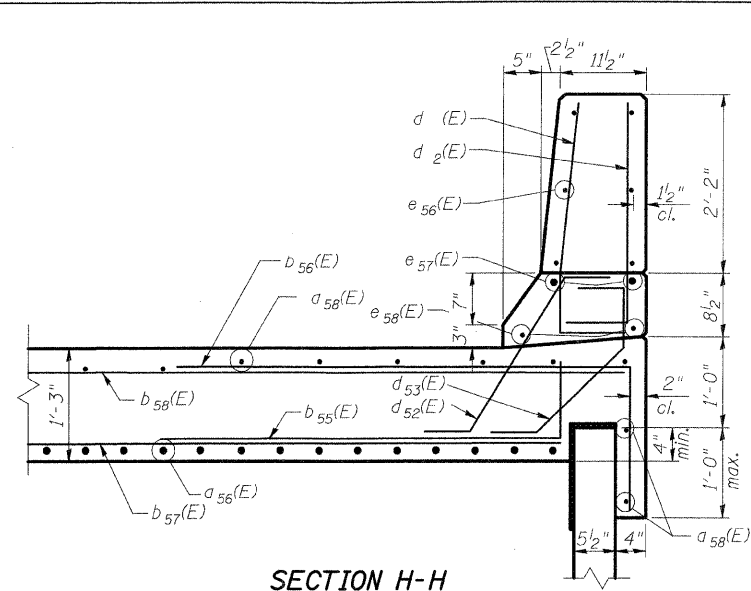

SECTION H-H

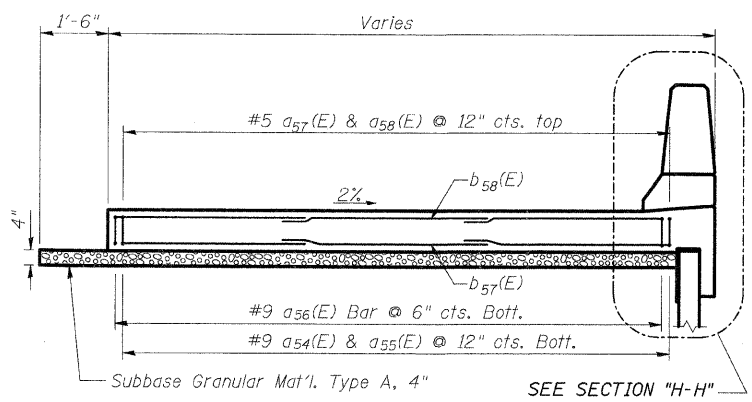

SECTION B-B

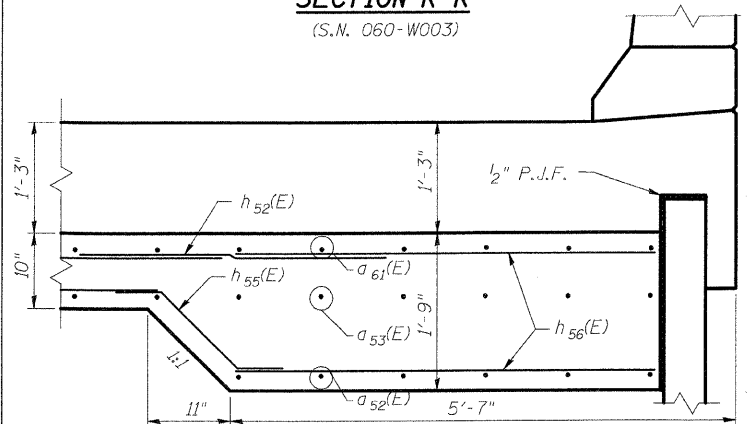

SECTION L-L

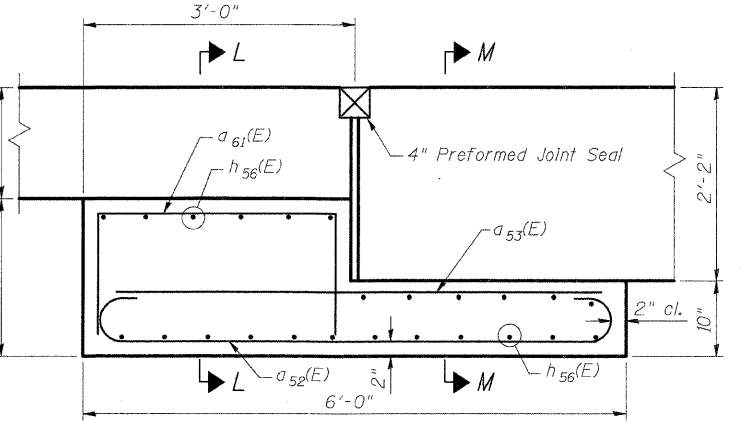

SECTION E-E

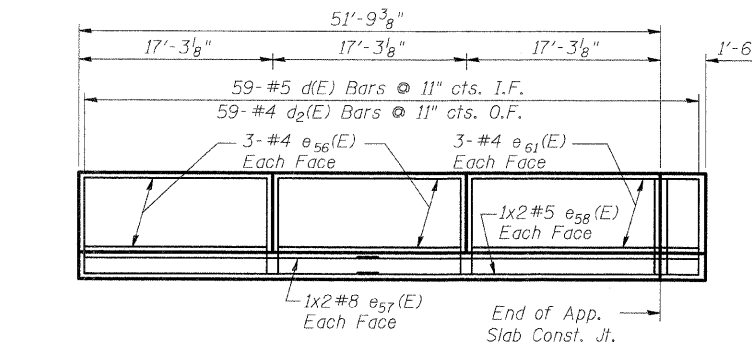

INSIDE PARAPET ELEVATION AT RAMP "C" APPROACH SLAB (SPECIAL)

MINIMUM BAR LAP

#4 bars = 1'-8"
#5 bars = 2'-2"
#9 bars = 5'-9"

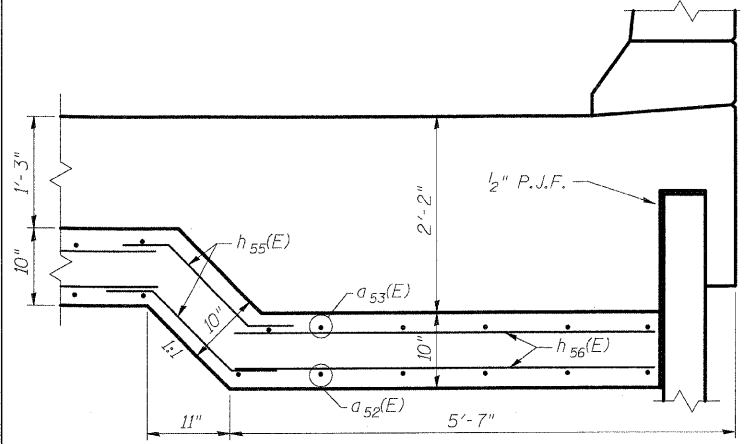

SECTION M-M

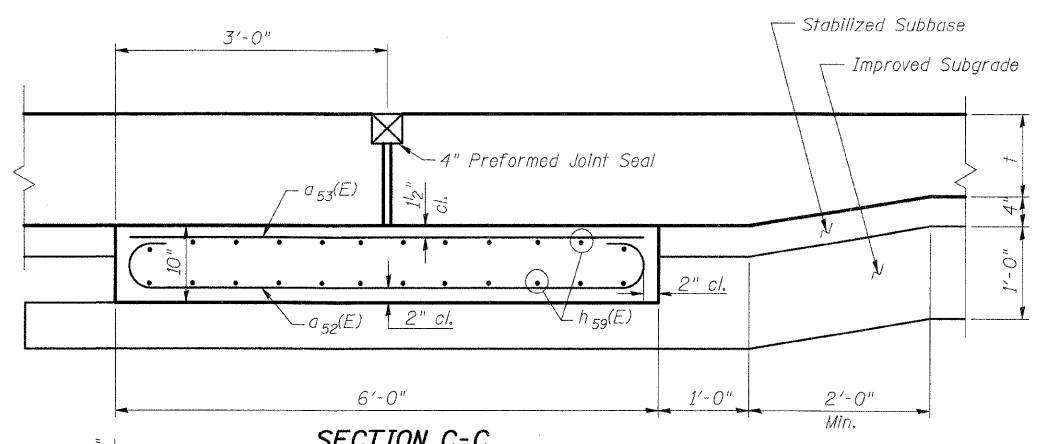

SECTION C-C

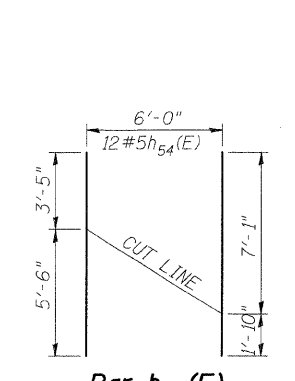

Bar h₅₄(E) CUTTING DIAGRAM

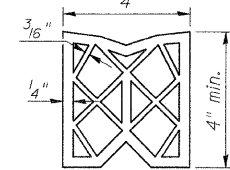

PREFORMED JOINT SEAL

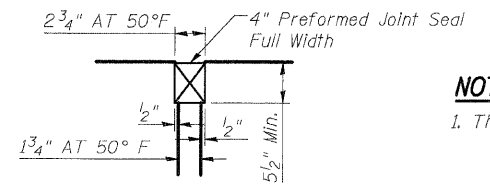

DETAIL 1

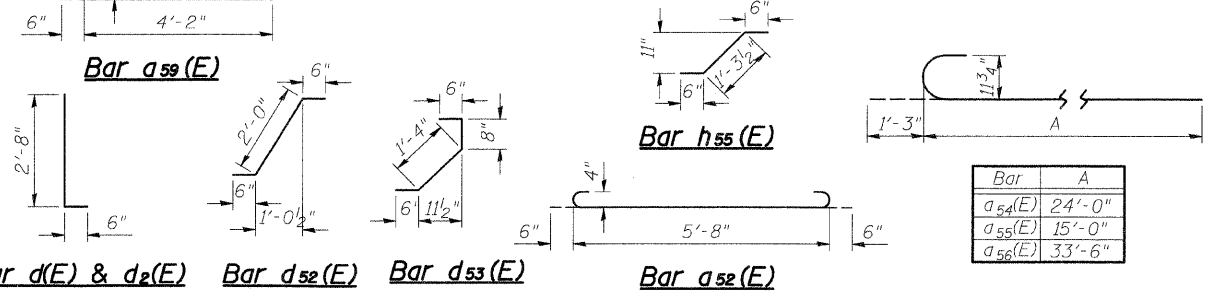
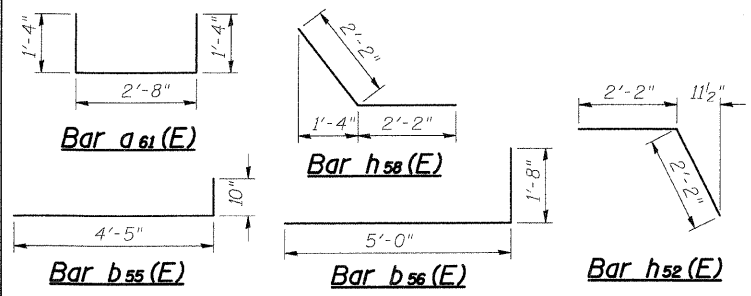

Bar	A
a ₅₄ (E)	24'-0"
a ₅₅ (E)	15'-0"
a ₅₆ (E)	33'-6"

SHT. 2 OF 2
STV Incorporated
Engineers/Architects/Planners/Construction Managers
200 W. Monroe Street, Suite 1650
Chicago, IL 60606-5015
312-553-0655, FAX 312-553-0661

REVISIONS	
NAME	DATE

ILLINOIS DEPARTMENT OF TRANSPORTATION
IL ROUTE 162 OVER I-55/70 IN TROY
F.A.I ROUTE 70 SECTION 60-10K-1, 60-10HB
MADISON COUNTY STATION 499+48.35
STRUCTURE NO. 060-0338
RAMP C APPROACH SLAB DETAILS (SPECIAL)
DESIGNED: JAW
CHECKED: BTO
DRAWN: BTO
CHECKED: JAN
DATE: 4/06