

MEDIAN 2 PLAN

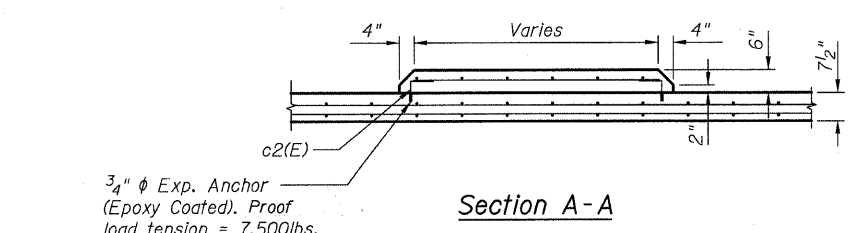

Section A-A

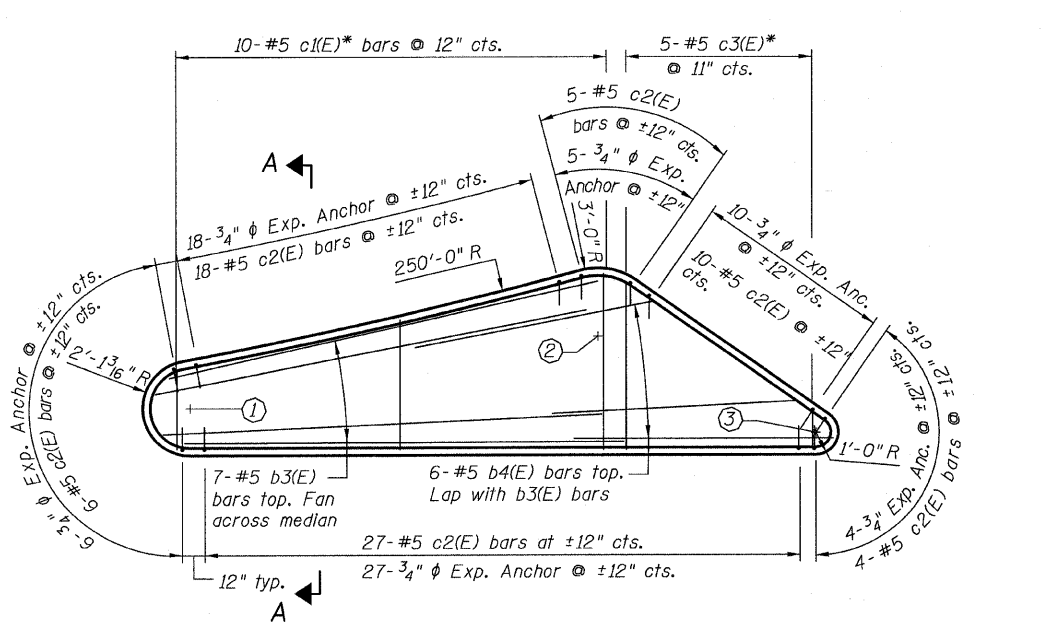

MEDIAN 1 PLAN

TABLE A  
CENTER OF RADIUS &  
EDGE OF MEDIAN FACE

Point	IL 162 STA.	IL 162 OFFSET
1	498+67.42	15.90 ft Rt.
2	498+85.45	12.73 ft Rt.
3	498+95.08	17.00 ft Rt.
4	499+38.24	1.68 ft Lt.
5	499+48.24	5.44 ft Lt.
6	499+58.47	1.68 ft Rt.
7	499+48.47	5.44 ft Lt.
8	500+01.64	17.00 ft Lt.
9	500+29.28	16.30 ft Lt.
10	500+09.95	13.65 ft Lt.
11	498+77.01	47.00 ft Lt.
12	498+81.19	67.76 ft Lt.
13	498+93.40	49.00 ft Lt.
14	500+03.04	49.00 ft Lt.
15	500+19.69	47.00 ft Lt.
16	500+15.43	68.08 ft Rt.

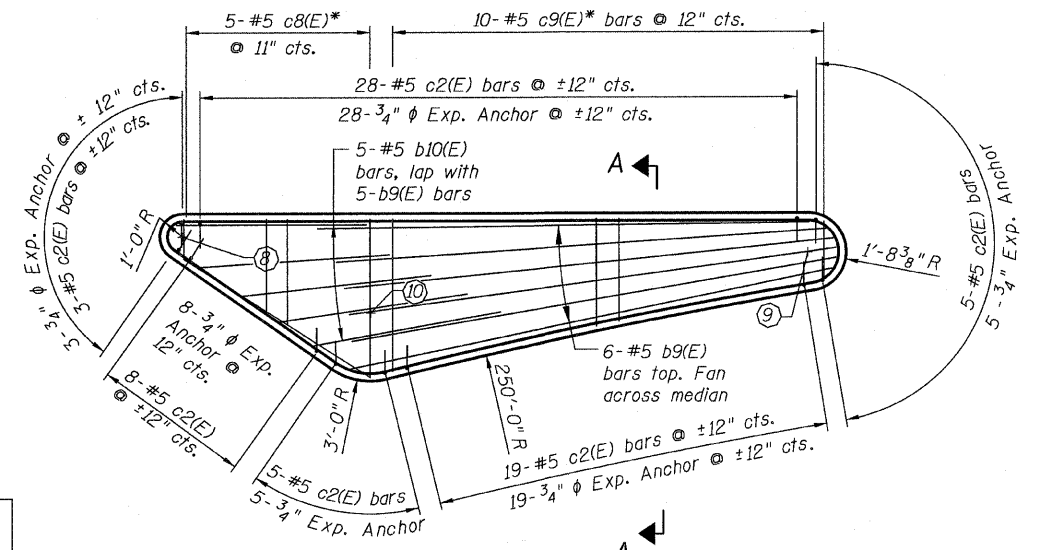

MEDIAN 3 PLAN

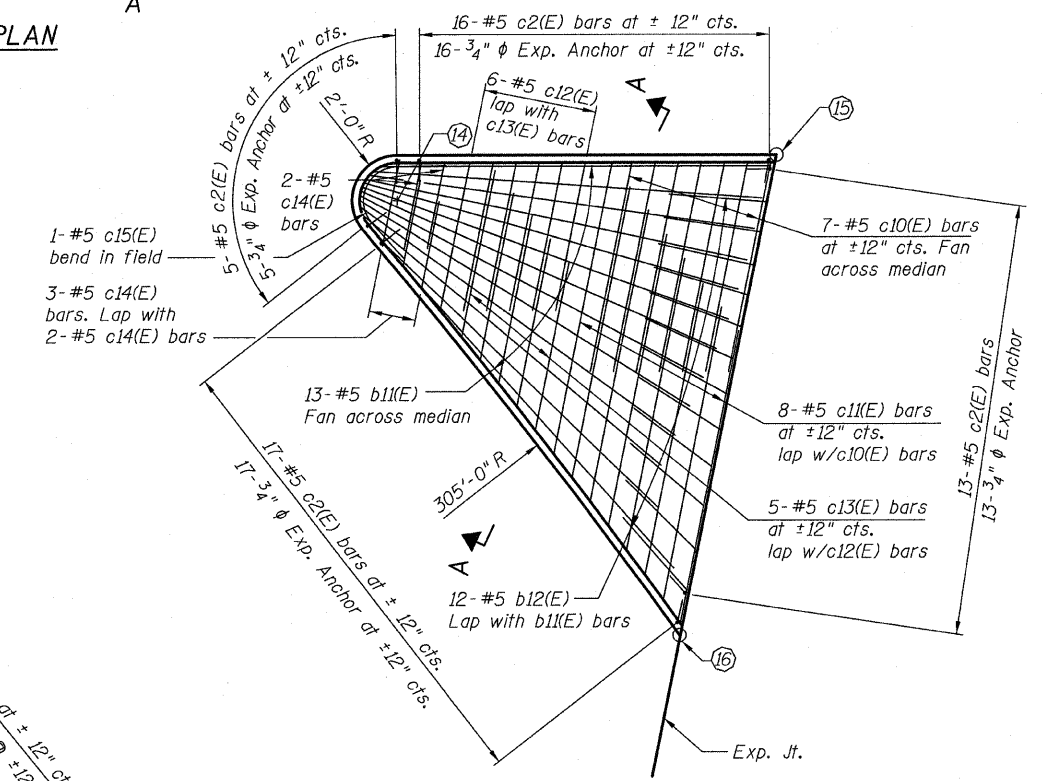

MEDIAN 5 PLAN

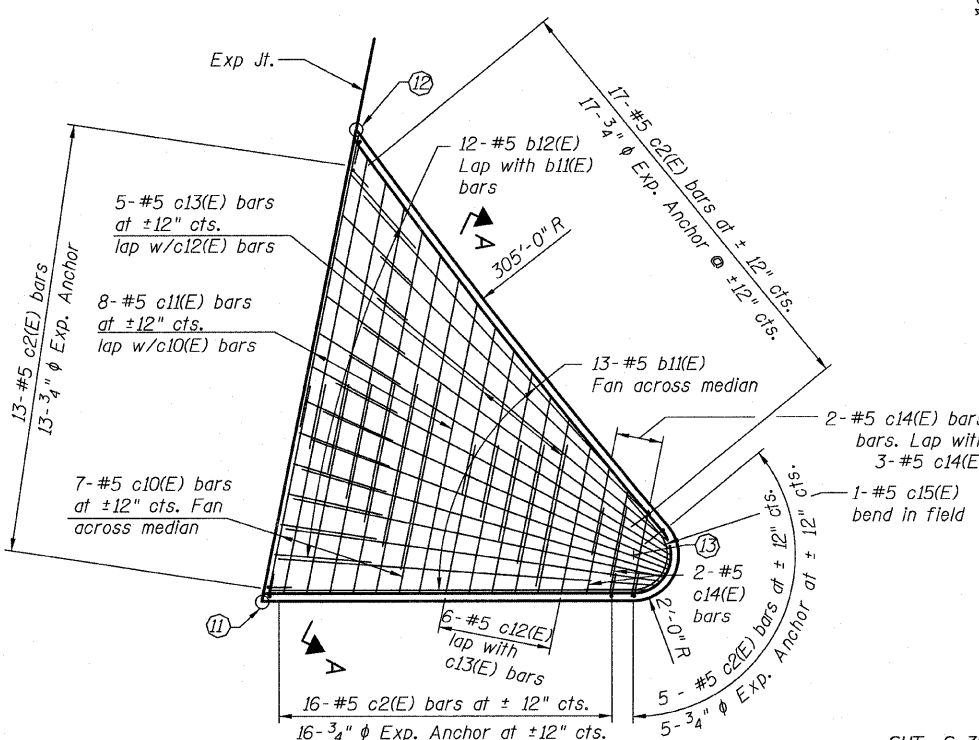

MEDIAN 4 PLAN

NOTES:

- ① Indicates center of median face radius or edge of median face. See Table A this sheet.
- Reinforcement bars designated (E) shall be epoxy coated.
- For Bill of Material, see Sht. S-31.
- \* - Order bars full length. Cut to fit skew and use remainder of bars in opposite end.

REVISIONS	
NAME	DATE

STV Incorporated  
Engineers/Architects/Planners/Constructive Managers  
200 W. Monroe Street, Suite 1650  
Chicago, IL 60606-5015  
312.633.0655, FAX 312.553-0661

ILLINOIS DEPARTMENT OF TRANSPORTATION  
IL ROUTE 162 OVER I-55/70 IN TROY  
F.A.I ROUTE 70 SECTION 60-10K-1, 60-10HB  
MADISON COUNTY STATION 499+48.35  
STRUCTURE NO. 060-0338  
SUPERIMPOSED MEDIAN DETAILS  
DESIGNED: BTO DRAWN: BTO  
CHECKED: JAW CHECKED: JAW  
DATE: 03/06

SHT. S-30 OF S-68