

CAST-IN-PLACE BARREL SECTION

LEFT SIDE X = 3'-0"
RIGHT SIDE X = 1'-2"

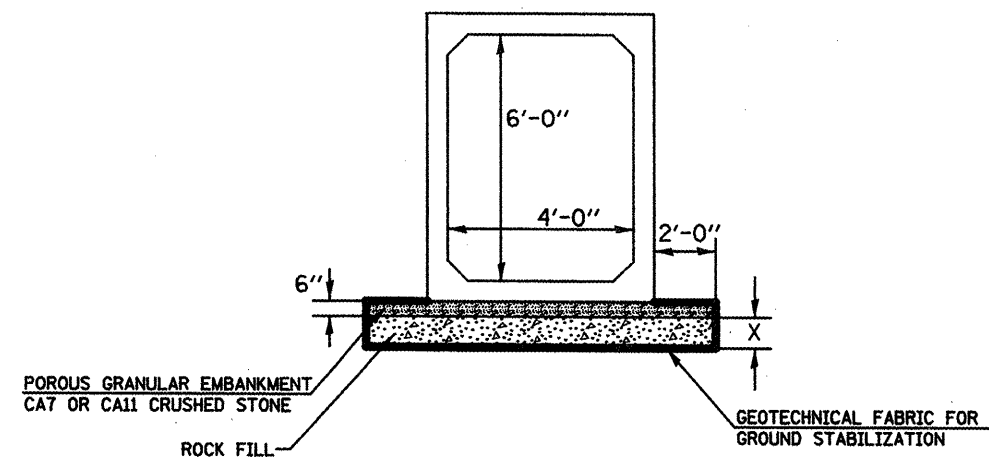

PRECAST BARREL SECTION

LEFT SIDE X = 3'-0"
RIGHT SIDE X = 1'-2"

NOTES:

1. THIS WORK SHALL BE PERFORMED IN ACCORDANCE WITH SECTION 503 OF THE STANDARD SPECIFICATION. STRUCTURE EXCAVATION AND BACKFILL SHALL BE IN ACCORDANCE WITH SECTION 502 AND PAYMENT FOR STRUCTURE EXCAVATION SHALL BE IN ACCORDANCE TO ARTICLE 502.13 OF THE STANDARD SPECIFICATIONS.
2. POROUS GRANULAR EMBANKMENT SHALL BE PLACED IN ACCORDANCE WITH ARTICLE 540.06 OF THE STANDARD SPECIFICATIONS AND SHALL BE INCLUDED IN THE COST OF THE PRECAST BOX CULVERT PAY ITEM. POROUS GRANULAR EMBANKMENT REQUIRED FOR THE CAST-IN-PLACE BOX CULVERT AND END SECTION SHALL BE PAID FOR SEPARATELY.
3. WRAP POROUS GRANULAR MATERIAL AND ROCK FILL IN FABRIC. THE FABRIC SHALL BE ACCORDING TO THE REQUIREMENTS OF THE APPLICABLE PORTIONS OF SECTION 1080 AND SECTION 282 WITH 6 OR 8 OZ/SQ YD MATERIAL ALLOWED.
4. A DEPTH OF 2 FEET AROUND CULVERT WAS ASSUMED TO BE UNSUITABLE THE ROCK FILL AND GEOTECHNICAL FABRIC FOR GROUND STABILIZATION SHALL BE PAID SEPARATELY.
5. REINFORCEMENT BARS SHALL CONFORM TO SECTION 508 OF THE STANDARD SPECIFICATION.

LOCATION	ROCK FILL	POROUS GRANULAR EMBANKMENT	GEOTECH. FABRIC	REMOVAL OF UNSUITABLE MATERIAL
	TON	TON	SQ YD	CU YD
LT. STA. 98+00	115.2	12.7	135.2	201.6
RT. STA. 98+00	44.0	12.7	106.7	167.1

DRAWING NOT TO SCALE