

ROUTE NO.	SECTION	COUNTY	TOTAL SHEETS	SHEET NO.
C.H. 36	07-00045-03-BR	McLEAN	27	21
FED. ROAD DIST. NO.		ILLINOIS	CONTRACT NO. 91388	

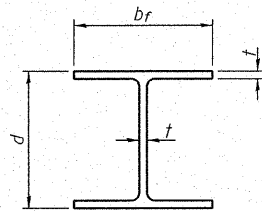

STEEL PILE TABLE

Designation	Depth d	Flange width bf	Web and Flange thickness t	Encasement diameter A
HP 14x117	14 1/4"	14 7/8"	13/16"	30"
x102	14"	14 3/4"	1/16"	30"
x89	13 7/8"	14 3/4"	5/8"	30"
x73	13 5/8"	14 5/8"	1/2"	30"
HP 12x84	12 1/4"	12 1/4"	1/16"	24"
x74	12 1/8"	12 1/4"	5/8"	24"
x63	12"	12 1/8"	1/2"	24"
x53	11 3/4"	12"	7/16"	24"
HP 10x57	10"	10 1/4"	9/16"	24"
x42	9 3/4"	10 1/8"	7/16"	24"
HP 8x36	8"	8 1/8"	7/16"	18"

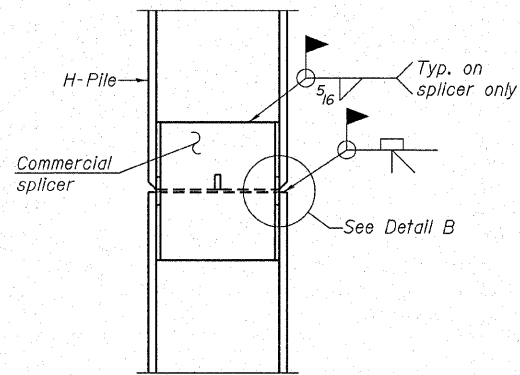

ELEVATION

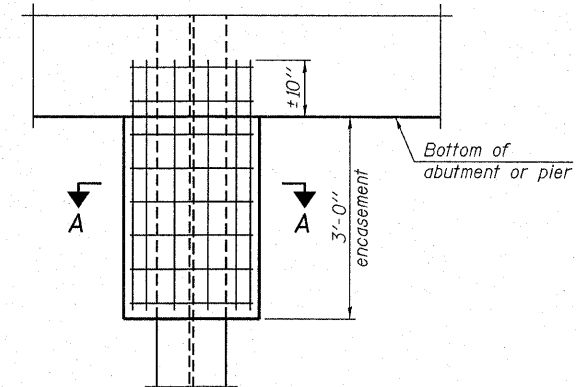

ELEVATION

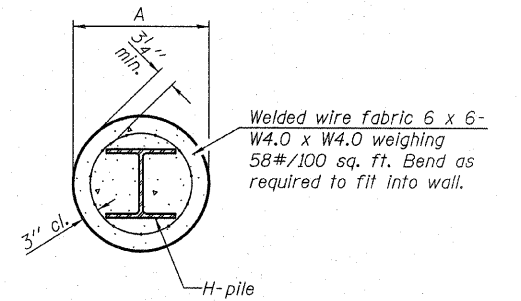

SECTION A-A

Note:  
Forms for encasement may be omitted when soil conditions permit.

PILE ENCASEMENT

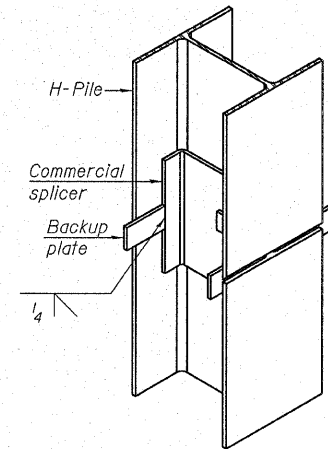

ISOMETRIC VIEW

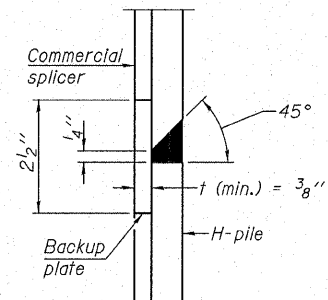

DETAIL "B"

WELDED COMMERCIAL SPLICE

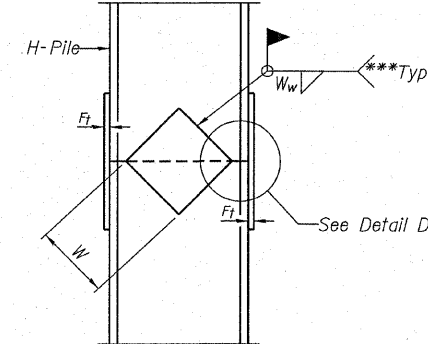

ELEVATION

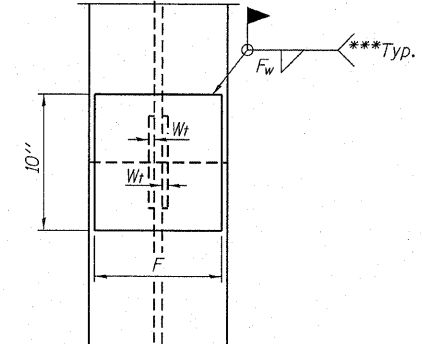

END VIEW

Designation	F	F <sub>t</sub>	F <sub>w</sub>	W	W <sub>t</sub>	W <sub>w</sub>
HP 14x117	12 1/2"	1"	7/8"	7 3/4"	5 1/2"	1/2"
x102	12 1/2"	7/8"	3/4"	7 3/4"	5 1/2"	1/2"
x89	12 1/2"	3/4"	1/16"	7 3/4"	5 1/2"	1/2"
x73	12 1/2"	5/8"	9/16"	7 3/4"	5 1/2"	1/2"
HP 12x84	10"	7/8"	1/16"	6 1/2"	5 1/2"	1/2"
x74	10"	7/8"	1/16"	6 1/2"	5 1/2"	1/2"
x63	10"	5/8"	1/2"	6 1/2"	1/2"	3/8"
x53	10"	5/8"	1/2"	6 1/2"	1/2"	3/8"
HP 10x57	8"	3/4"	9/16"	5 1/4"	1/2"	3/8"
x42	8"	5/8"	9/16"	5 1/4"	1/2"	3/8"
HP 8x36	7"	5/8"	7/16"	4 1/4"	1/2"	3/8"

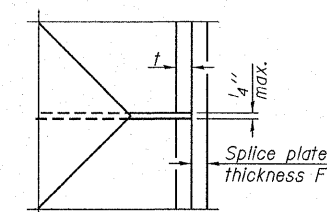

DETAIL D

WELDED PLATE FIELD SPLICE

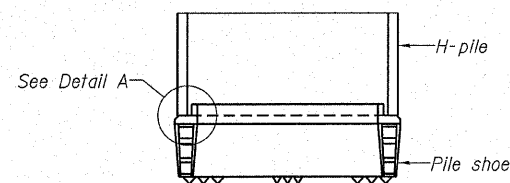

ELEVATION

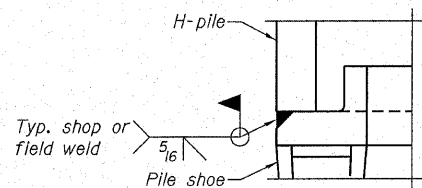

DETAIL A

H-PILE SHOE ATTACHMENT

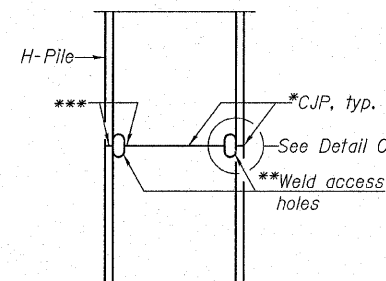

ELEVATION

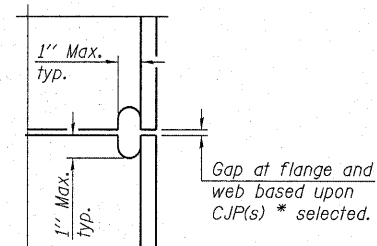

DETAIL C

COMPLETE PENETRATION WELD SPLICE

Note:  
The steel H-piles shall be according to AASHTO M270 Grade 50.

- \* Use joint conforming to Figure 3.4 in AWS D1.1, Structure Welding Code - Steel.
- \*\* Preparation per Fig. 5.2 in AWS D1.1, Structure Welding Code - Steel.
- \*\*\* Interrupt welds 1/4" from end of each pile.

	<b>HAMPTON, LENZINI &amp; RENWICK, INC.</b> CIVIL & STRUCTURAL ENGINEERS LAND SURVEYORS 3085 STEVENSON DRIVE, SUITE 201 SPRINGFIELD, ILLINOIS 62703 (217) 548-3400	<p align="center"><b>STEEL H PILE DETAILS</b></p> <p align="center">C.H. 36 / F.A.S. 487</p> <p align="center">SECTION 07-00045-03-BR</p> <p align="center">McLEAN COUNTY</p> <p align="center">STRUCTURE NO. 057-3211 / STATION 10+00</p>
	ELGIN • SPRINGFIELD PROJECT NUMBER: 12-59-0055-1    DATE: 01/22/09 DESIGNED: P.S.L.    CHECKED: S.W.M.    DRAWN: D.A.B.	