

PROPOSED TYPICAL SECTION
WINDSOR ROAD STA. 71+70 TO STA. 72+54.53
WINDSOR ROAD STA. 74+62.47 TO STA. 78+50

NOTE: IF AN ANTI-STRIPING ADDITIVE IS REQUIRED FOR ANY HOT-MIX ASPHALT MIXTURE, THE COST OF THE ADDITIVE WILL NOT BE PAID FOR SEPARATELY AS DESCRIBED IN ARTICLE 406.14 OF THE STANDARD SPECIFICATIONS. IF THE CONTRACTOR ANTICIPATES THAT AN ADDITIVE WILL BE NEEDED, THE COST SHOULD BE INCLUDED IN THE UNIT BID PRICE.

- NOTES:**
- HOT-MIX ASPHALT BINDER SHALL BE PLACED IN ACCORDANCE WITH ARTICLE 407.6 (C) OF THE STANDARD SPECIFICATIONS.
 - BITUMINOUS MATERIALS (PRIME COAT) SHALL BE APPLIED BETWEEN ALL LIFTS OF HMA AT A RATE OF 0.03 TO 0.05 GAL/SQ. YD.
 - THE EXISTING EARTH SHALL BE UNDERCUT BELOW THE PROPOSED PAVEMENT TO THE DEPTH AND LOCATION SHOWN ON THE CROSS SECTIONS. AGGREGATE SUBGRADE, SPECIAL AND/OR AGGREGATE BASE COURSE, TYPE A SHALL BE PLACED AND COMPACTED IN THE UNDERCUT AREAS. THE EARTH FROM THE UNDERCUT AREAS SHALL BE PLACED AS EMBANKMENT IN FILL AREAS BEHIND THE PROPOSED BACK OF CURBS. UNDERCUT WILL NOT BE ALLOWED AS FILL UNDER PAVEMENTS OR SIDEWALKS. EXCESS VOLUME OF UNDERCUT EXCAVATED WHICH IS NOT USED FOR EMBANKMENT AND IS WASTE AND IS DISPOSED OF OFF THE SITE WILL NOT BE PAID FOR SEPARATELY AND NO ADDITIONAL COMPENSATION WILL BE ALLOWED. EMBANKMENT WILL NOT BE PAID FOR SEPARATELY AND SHALL BE INCLUDED IN THE COST OF THE OTHER EARTHWORK ITEMS. SEE THE CROSS SECTIONS AND THE SPECIAL PROVISIONS FOR ADDITIONAL INFORMATION.
 - THE TOPSOIL THAT IS EXCAVATED SHALL BE STOCKPILED AND USED FOR TOPSOIL PLACEMENT. THIS WORK SHALL BE PAID FOR AT THE CONTRACT UNIT PRICE PER CUBIC YARD FOR TOPSOIL EXCAVATION AND PLACEMENT. THE EXCESS VOLUME OF TOPSOIL EXCAVATED AND NOT USED FOR TOPSOIL PLACEMENT SHALL BE PLACED AS EMBANKMENT IN FILL AREAS BEHIND THE PROPOSED BACK OF THE CURBS. TOPSOIL WILL NOT BE ALLOWED TO BE PLACED AS FILL UNDER PAVEMENTS OR SIDEWALKS. THE EXCESS VOLUME OF TOPSOIL EXCAVATED WHICH IS NOT USED FOR TOPSOIL PLACEMENT OR PLACED IN THE EMBANKMENT AREAS AND IS WASTE AND IS REMOVED AND DISPOSED OF OFF THE SITE WILL NOT BE PAID FOR SEPARATELY AND NO ADDITIONAL COMPENSATION WILL BE ALLOWED. EMBANKMENT WILL NOT BE PAID FOR SEPARATELY AND SHALL BE INCLUDED IN THE COST OF THE OTHER EARTHWORK ITEMS.
 - SEE PLAN AND PROFILE SHEETS FOR THE EXACT LOCATIONS OF EDGES OF PAVEMENTS, CURB AND GUTTERS, SIDEWALKS AND RIGHT-OF-WAY LINES. SEE CROSS SECTIONS FOR EXACT SIDE SLOPE RATIOS.
 - SEE SCHEDULE OF QUANTITIES SHEETS FOR LOCATIONS OF HOT-MIX ASPHALT SURFACE REMOVAL VARIABLE DEPTH, HOT-MIX ASPHALT SURFACE REMOVAL 2 1/2", AGGREGATE SUBGRADE (SPECIAL), PROCESSING MODIFIED SOIL, AND AGGREGATE BASE COURSE, TYPE A.
 - THE MEDIAN AREA SHALL BE BACKFILLED WITH EARTH AND TOPSOIL. TOPSOIL SHALL BE PLACED IN THE TOP TWO FEET OF THE MEDIAN AREA.
 - AT SELECT LOCATIONS ON TYPICAL SECTIONS PLACE TOP OF AGGREGATE BASE COURSE, TYPE A EVEN WITH TOP OF EXISTING PAVEMENT SURFACE. SEE CROSS SECTIONS FOR FURTHER INFORMATION.

STRUCTURAL PAVEMENT DESIGN INFORMATION	
WINDSOR ROAD - PAVEMENT WIDENING	
STRUCTURAL DESIGN TRAFFIC:	YEAR 2019
PV = 12350	SU = 260 MU = 390
ROAD/STREET CLASSIFICATION:	CLASS 1
PERCENT OF STRUCTURAL DESIGN TRAFFIC IN DESIGN LANE:	
P = 50%	S = 50% M = 50%
TRAFFIC FACTOR:	TF = 2.02
SUBGRADE SUPPORT RATING:	SSR = "POOR"
MINIMUM STRUCTURAL DESIGN REQUIREMENTS:	
HMA SURFACE COURSE	= 2"
HMA CONCRETE BINDER COURSE	= 9.5"
MODIFIED SUBGRADE OR AGGREGATE BASE COURSE, TYPE A	= 12"

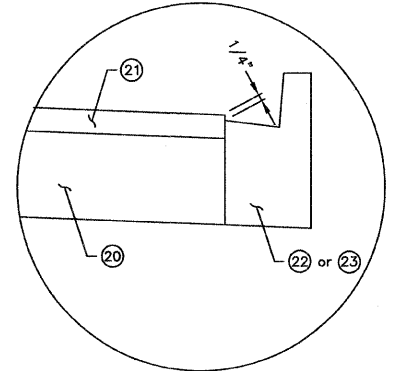

HMA ADJACENT TO COMBINATION CONCRETE CURB AND GUTTER (TYPICAL)

HOT-MIX ASPHALT MIXTURE REQUIREMENTS

LOCATION	WINDSOR RD		MULTI-USE PATH		ENTRANCES	
	WIDENING & BINDER	2" POLYMER SURFACE	4 1/2" BINDER	1 1/2" SURFACE	6" BINDER	2" OR 3" SURFACE
AC/PG	PG 64-22	SBS PG 64-28	PG 64-22	PG 64-22	PG 64-22	PG 64-22
RAP % (MAX)	10	10	30	30	25	15
DESIGN AIR VOIDS	4.0% @ NDES=90	4.0% @ NDES=90	4.0% @ NDES=30	4.0% @ NDES=30	4.0% @ NDES=50	4.0% @ NDES=50
MIX COMP (GRADATION)	IL 19.0	IL 9.5	IL 19.0L	IL 9.5L	IL 19.0	IL 9.5
FRICION AGGREGATE	N.A.	MIX D	N.A.	MIX C	N.A.	MIX C

NOTE: SIDE STREET PROPOSED PAVEMENT SHALL BE "PORTLAND CEMENT CONCRETE PAVEMENT 7" ATOP 4" MINIMUM OF "SUB-BASE GRANULAR MATERIAL, TYPE B"

- LEGEND**
- (11) PR PAVEMENT REMOVAL
 - (12) PR REMOVAL AND DISPOSAL OF UNSUITABLE MATERIAL
 - (13) PR AGGREGATE SUBGRADE (SPECIAL)
 - (14) PR AGGREGATE BASE COURSE, TYPE A
 - (15) PR PROCESSING MODIFIED SOIL
 - (16) PR HOT-MIX ASPHALT SURFACE REMOVAL, VARIABLE DEPTH
 - (17) PR HOT-MIX ASPHALT SURFACE REMOVAL, 2 1/2"
 - (18) PR STRIP REFLECTIVE CRACK CONTROL TREATMENT
 - (19) PR BITUMINOUS MATERIALS (PRIME COAT)
 - (20) PR HOT-MIX ASPHALT BINDER COURSE, IL-19.0, N90
 - (21) PR POLYMERIZED HOT-MIX ASPHALT SURFACE COURSE, MIX "D", N90
 - (22) PR COMBINATION CONCRETE CURB AND GUTTER, TYPE B-6.12
 - (23) PR COMBINATION CONCRETE CURB AND GUTTER, TYPE B-6.24
 - (24) PR PORTLAND CEMENT CONCRETE SIDEWALK, 6"
 - (25) PR HOT-MIX ASPHALT BINDER COURSE, IL-19L, N30
 - (26) PR HOT-MIX ASPHALT SURFACE COURSE, MIX "C", N30
 - (27) PR SEGEMENTAL CONCRETE BLOCK WALL
 - (28) PR SEGEMENTAL CONCRETE BLOCK WALL, SPECIAL
 - (29) PR HANDRAIL
 - (30) PR STONE DUMPED RIPRAP, CLASS A3
 - (31) PR TOPSOIL 4"
 - (32) PR SEEDING AND MULCH
 - (33) PR SODDING
 - (34) PR SUB-BASE GRANULAR MATERIAL, TYPE B

MAR 19 2009 3:52PM PRITYSEC01.DWG