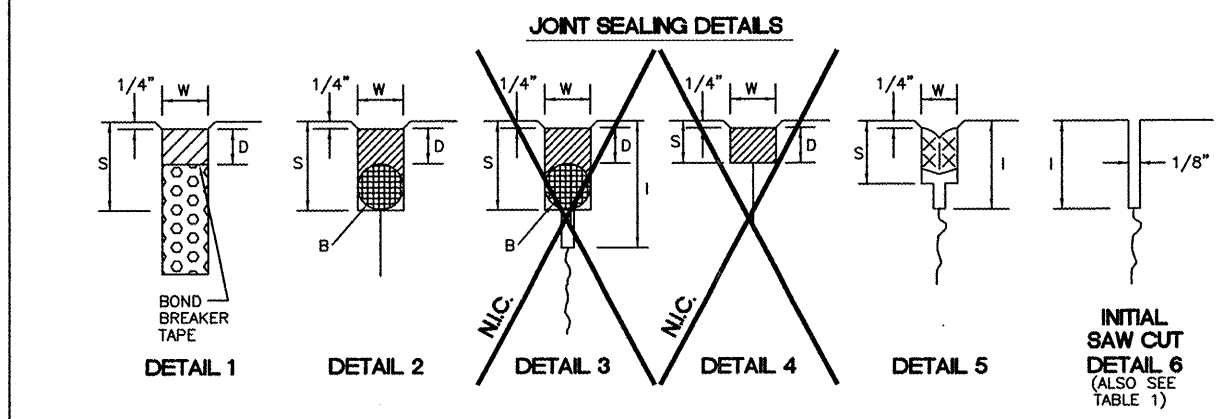
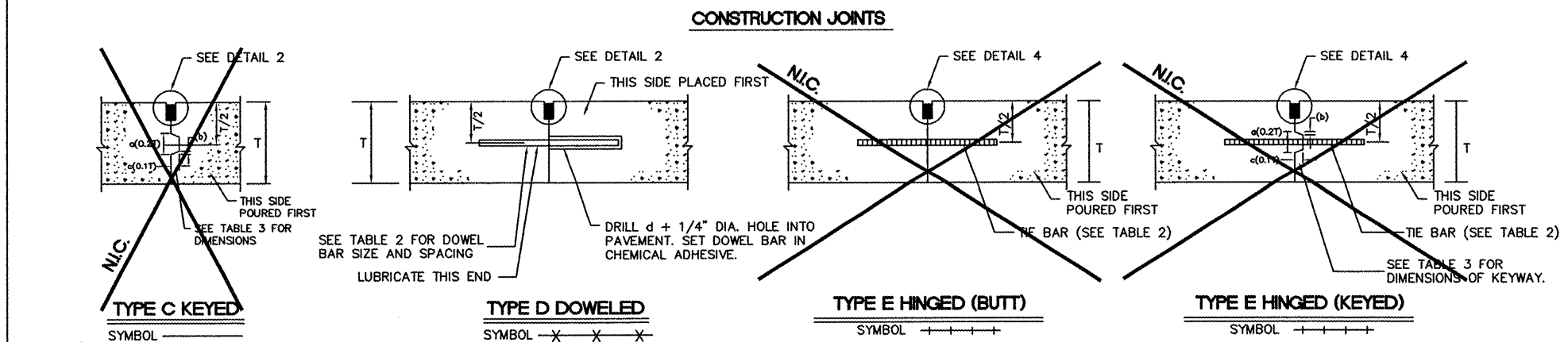
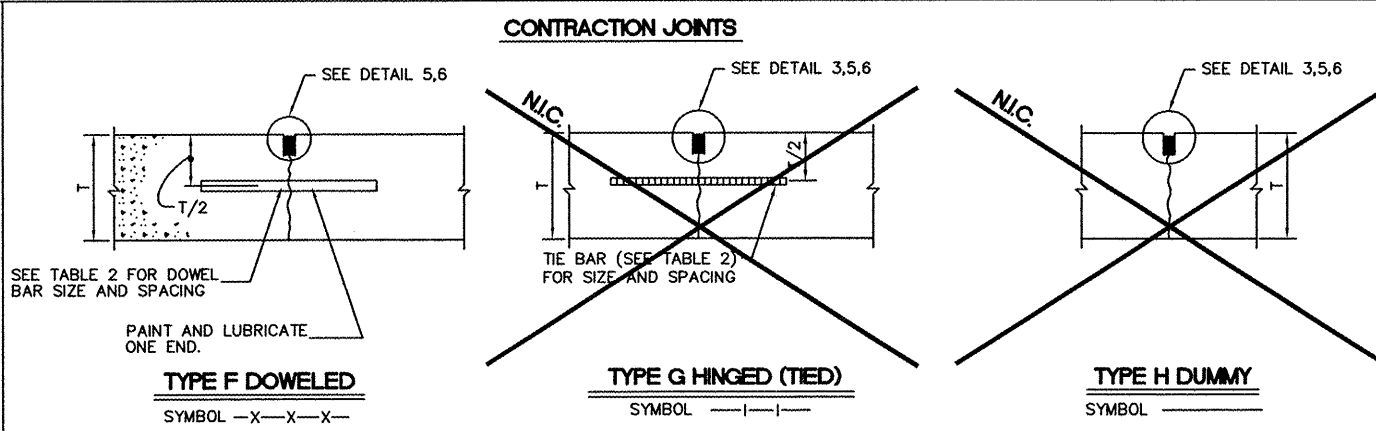
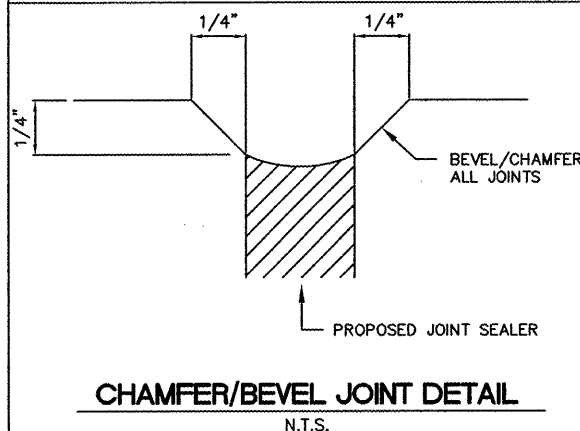
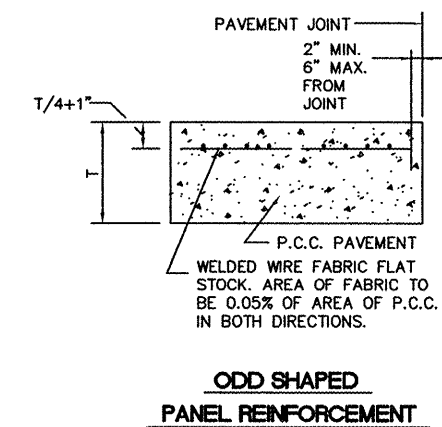
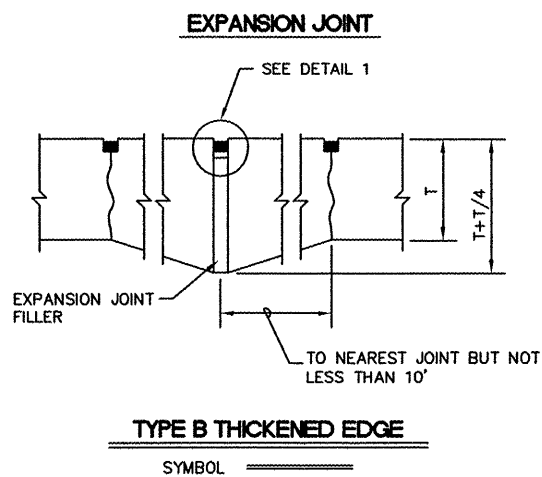

TABLE 1

PAVEMENT THICKNESS T - INCHES	DEPTH OF CONTRACTION JOINT INITIAL SAW CUT I, INCHES I=(T/3) ± 1/4"
5	1.67"
6	2.00"
7	2.33"
8	2.67"
9	3.00"
10	3.33"
11	3.67"
12	4.00"
13	4.33"
14	4.67"
15	5.00"
16	5.33"
17	5.67"
18	6.00"

TABLE 2

PAVEMENT THICKNESS T - INCHES	DOWEL BAR DETAILS			TIE BAR DETAILS		
	DIA.	LENGTH	SPACING	BAR SIZE	LENGTH	SPACING
5	5/8"	12"	12"	#4	24"	30"
6	3/4"	18"	12"	#5	30"	30"
7	3/4"	18"	12"	#5	30"	30"
8	1"	19"	12"	#5	30"	30"
9	1"	19"	12"	#5	30"	30"
10	1"	19"	12"	#5	30"	30"
11	1"	19"	12"	#5	30"	30"
12	1"	19"	12"	#5	30"	30"
13	1 - 1/4"	20"	15"	#5	30"	30"
14	1 - 1/4"	20"	15"	#5	30"	30"
15	1 - 1/4"	20"	15"	#5	30"	30"
16	1 - 1/4"	20"	15"	#5	30"	30"
17	1 - 1/2"	20"	18"	#5	30"	30"
18	1 - 1/2"	20"	18"	#5	30"	30"



NOTE: JOINT SEALING SHALL BE PER SECTION 605 OF SPECIAL PROVISIONS.

	DETAIL 1	DETAIL 2	DETAIL 3	DETAIL 4	DETAIL 5
	HOT POUR	HOT POUR	HOT POUR	HOT/COLD POUR	SILICONE PREFORMED
W=WIDTH OF SEALANT RESERVOIR (IN.)	1-1/2	1/2	1/2	1/2	3/8
D=DEPTH OF SEALANT RESERVOIR (IN.)	1-1/2	1/2	1/2	1/2	1/4
B=BACKER ROD DIAMETER (IN.)	N/A	5/8	5/8	N/A	N/A
S=SECOND SAWCUT DEPTH (IN.) MINIMUM	N/A	1-3/8	1-3/8	3/4	1-1/2

JOINTING NOTES

- ALL EDGES OF NEW SLABS, FREE STANDING OR CLOSURE, SHALL BE EDGED WITH AN APPROVED TOOL HAVING A RADIUS OF 1/8" TO 1/4" TO FACILITATE SAWING OF THE SEALANT RESERVOIR. A RADIUS > 1/4" WILL NOT BE ACCEPTABLE.
- THE INITIAL SAWCUT FOR ALL LONGITUDINAL AND TRANSVERSE CONTRACTION JOINTS SHALL BE SAWS AS SOON AS POSSIBLE AFTER PLACEMENT OF THE PAVEMENT.
- ALL DOWEL BARS SHALL BE SECURELY HELD IN PLACE BY MEANS OF A DOWEL BAR ASSEMBLY WHICH WILL ENSURE THAT THEY WILL REMAIN PARALLEL TO THE PAVEMENT LANES. THE DOWEL BAR ASSEMBLIES SHALL BE APPROVED BY THE RESIDENT ENGINEER PRIOR TO INSTALLATION. ALTERNATE METHODS OF PLACEMENT OF DOWEL BARS MAY BE PROPOSED BY THE CONTRACTOR TO BE APPROVED BY THE ENGINEER. TRANSVERSE DOWEL BAR IMPLANTING WILL NOT BE ALLOWED.
- ALL TIE BARS AND MESH SHALL BE SECURELY HELD IN PLACE BY SUPPORT PINS OR OTHER APPROVED METHODS TO PREVENT SHIFTING DURING AND AFTER CONCRETE PLACEMENT.
- THE INITIAL SAWCUT SHALL BE MADE TO THE 1/8" WIDTH INDICATED. INITIAL SAWING TO THE DIMENSIONS OF THE SECOND SAWCUT WILL NOT BE ALLOWED.
- COST OF ALL JOINT SAWING, CLEANING AND SEALING SHALL BE CONSIDERED INCIDENTAL TO THE ASSOCIATED PAY ITEM AND NO SEPARATE PAYMENT SHALL BE MADE.
- SHOULD THE POURING OPERATION REQUIRE THE INSERTION OF AN INTERMEDIATE HEADER, A DOWEL BASKET ASSEMBLY OR OTHER APPROVED METHOD OF DOWEL BAR PLACEMENT SHALL BE REQUIRED.
- EPOXY-COATED DOWEL BASKET ASSEMBLIES MEETING IDOT APPROVAL MAY BE PROPOSED BY THE CONTRACTOR TO BE APPROVED BY THE RESIDENT ENGINEER. DOWELS IN THE APPROVED BASKET ASSEMBLIES SHALL CONFORM TO TABLE 2.
- CONCRETE / BITUMINOUS INTERFACE SHALL BE SEALED PER TYPE E HINGED JOINT DETAIL ABOVE.
- ALL TIE BARS AND MESH SHALL BE SECURELY HELD IN PLACE BY SUPPORT PINS OR OTHER APPROVED METHODS TO PREVENT SHIFTING DURING AND AFTER CONCRETE PLACEMENT.
- TIE BARS SHALL BE DEFORMED BARS IN CONFORMANCE WITH THE SPECIFICATIONS.
- CONTRACTOR SHALL CONSTRUCT A 1/4" CHAMFER ON ALL CONCRETE JOINTS AT NO ADDITIONAL COST.
- JOINTS SHALL BE DRY AND CLEAN BEFORE SEALING OPERATIONS BEGIN.

JOINTING DETAILS (JTD1)

RO016



Chicago Rockford International Airport

FLYRFD.COM

Rockford, Illinois
Greater Rockford Airport Authority

AIP: 3-17-0088-XX
RFD-3862

Rehab. Txy B South (Phase 1)

Revisions

Date	Description

0 1
THIS BAR IS EQUAL TO 1" AT FULL SCALE (17 X 11).

DESIGN BY: CMT-RFD
DRAWN BY: CMT-RFD
CHECKED BY: CMT-RFD
APPROVED BY: JGP
DATE: 2-27-2009
JOB No: 06258-04-00

JOINTING DETAILS (JTD1)

24