

EROSION CONTROL DETAILS FOR SILT FENCE

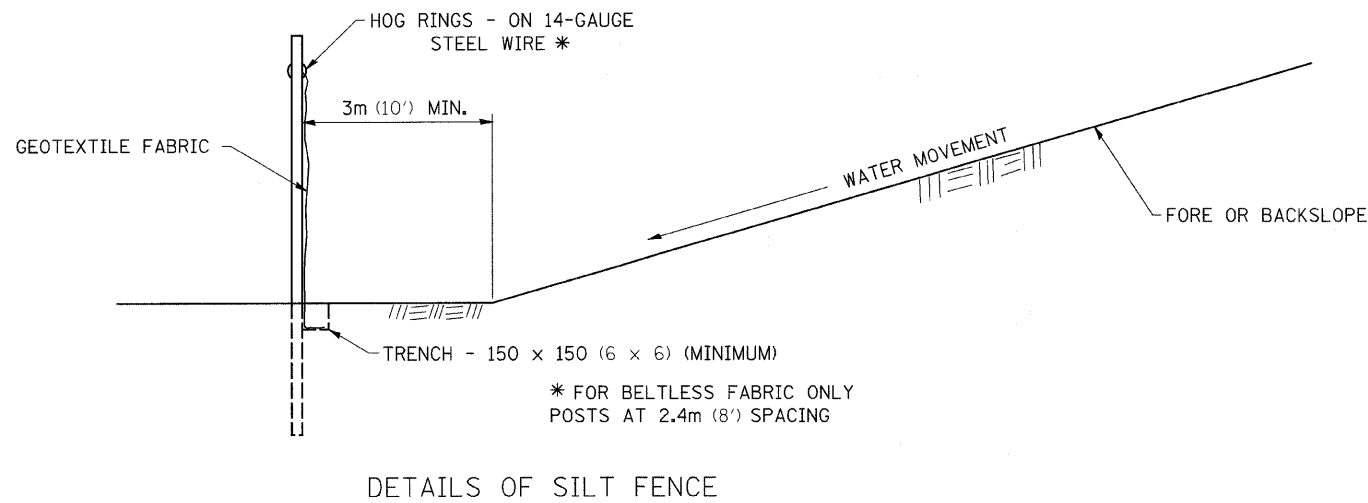
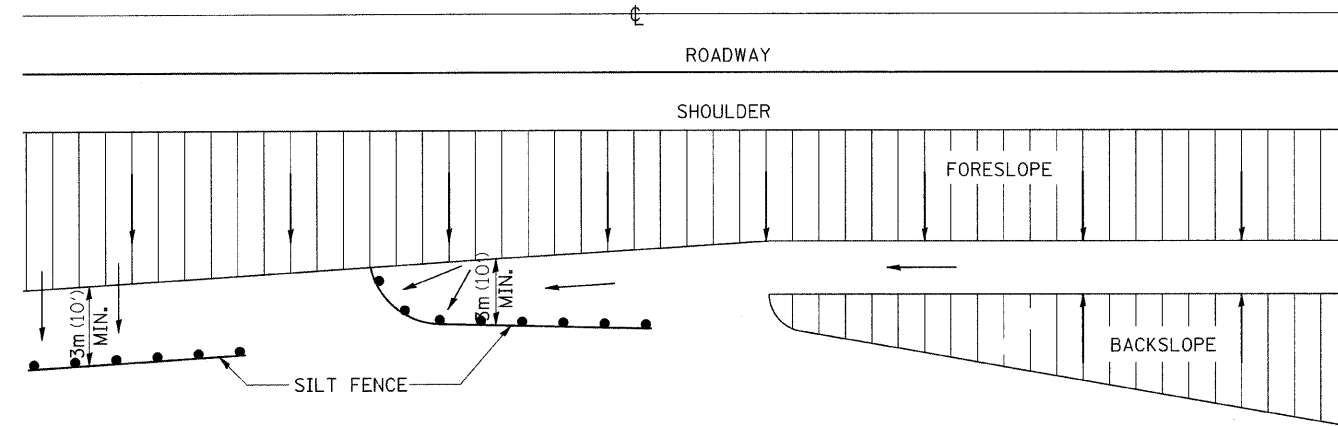

DETAILS OF SILT FENCE

ALL DIMENSIONS ARE IN MILLIMETERS (INCHES) UNLESS OTHERWISE NOTED.

WITNESS MARKER FOR PERMANENT SURVEY MARKERS, TYPE II

CONTRACT NO. 64C75				
F.A.P. RTE.	SECTION	COUNTY	TOTAL SHEETS	SHEET NO.
316	102T	LEE	40	23
STA.		TO STA.		
FED. ROAD DIST. NO.		ILLINOIS FED. AID PROJECT		

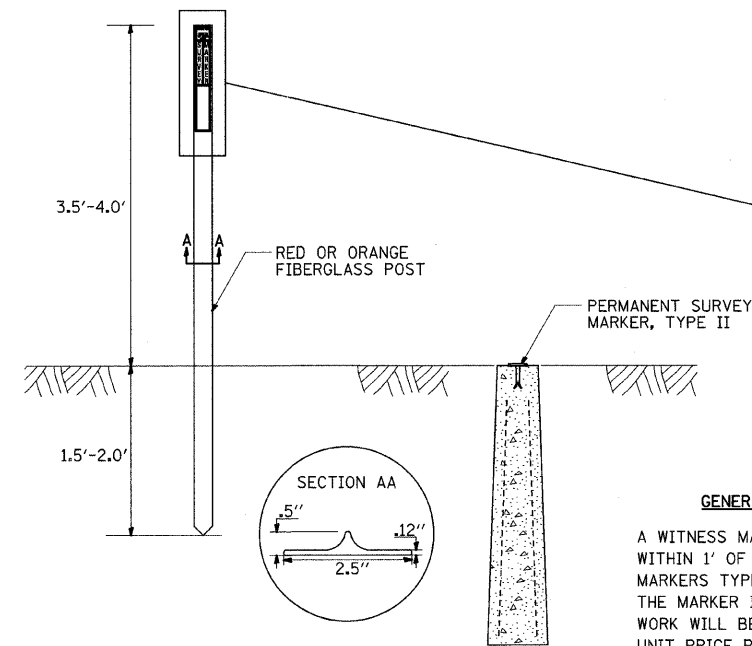

GENERAL NOTES

A WITNESS MARKER SHALL BE INSTALLED WITHIN 1' OF ALL PERMANENT SURVEY MARKERS TYPE II EXCEPT IN AREAS WHERE THE MARKER IS IN THE SIDEWALK. THIS WORK WILL BE INCLUDED TO THE CONTRACT UNIT PRICE PER EACH FOR PERMANENT SURVEY MARKERS, TYPE II.

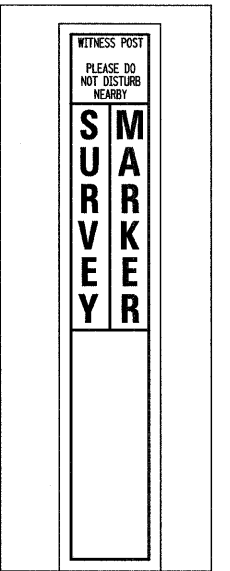

PERMANENT SURVEY MARKERS, TYPE II

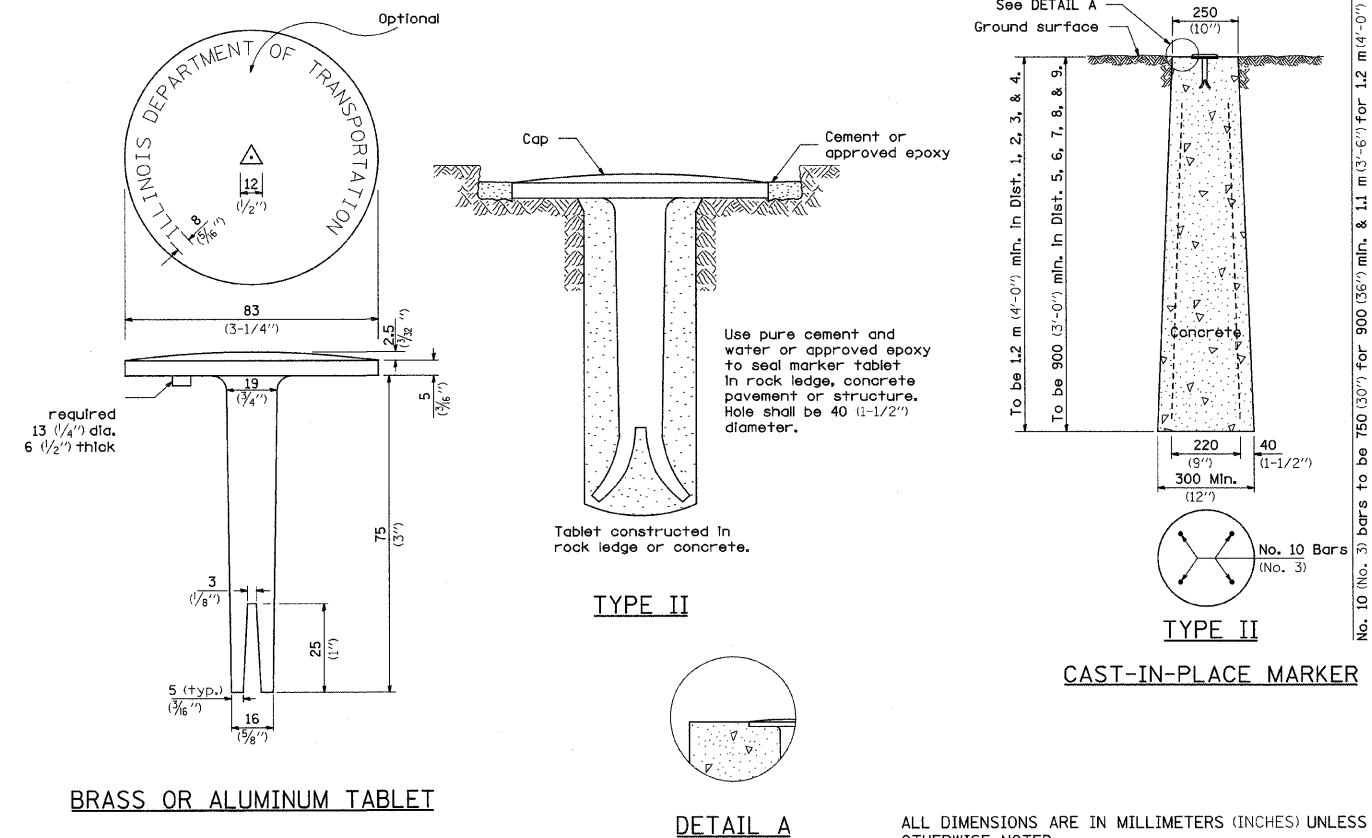

BRASS OR ALUMINUM TABLET

DETAIL A

CAST-IN-PLACE MARKER

ALL DIMENSIONS ARE IN MILLIMETERS (INCHES) UNLESS OTHERWISE NOTED.

PLT DATE = Thu Jan 24 15:56:26 2008
 FILE NAME = C:\p\projects\20080507\4886687.rvt.dgn
 PLOT SCALE = 50.00000 / IN.
 REFERENCE = #REF#